

TECHNICAL MANUAL

**AVIATION UNIT AND AVIATION
INTERMEDIATE MAINTENANCE MANUAL**

CH-47D HELICOPTER

DISTRIBUTION STATEMENT A: Approved for public release; distribution is unlimited.

**CHANGE
NO. 1**

**HEADQUARTERS
DEPARTMENT OF THE ARMY
WASHINGTON, D.C., 30 SEPTEMBER 2003**

**Aviation Unit and Aviation Intermediate
Maintenance Manual**

CH-47D HELICOPTER

DISTRIBUTION STATEMENT A: Approved for public release; distribution is unlimited.

TM 55-1520-240-23-11, 19 September 2002, is changed as follows:

1. Remove and insert pages as indicated below. New or changed text material is indicated by a vertical bar in the margin. An illustration change is indicated by a miniature pointing hand.

Remove pages

A/(B blank)
i/(ii blank)
A-1 through A-4
B-79 and B-80
B-87 through B-94
E-37 and E-38
E-129 and E-130
E-401/(E-402 blank)
Glossary-1 through Glossary-6
Index-1 through Index-38

Index-39 through Index-56

Index-57 through Index-152
Index-153/(Index-154 blank)

Insert Pages

A/(B blank)
i/(ii blank)
A-1 through A-4
B-79 and B-80
B-87 through B-94
E-37 and E-38
E-129 and E-130
E-401 and E-402
Glossary-1 through Glossary-6
Index-1 through Index-38
Index-38.1 and Index-38.2
Index-39 through Index-56
Index-56.1 through Index-56.6
Index-57 through Index-152
Index-153/(Index-154 blank)

2. Retain this sheet in front of the manual for reference purposes.

TM 55-1520-240-23-11

C1

By Order of the Secretary of the Army:

Official:

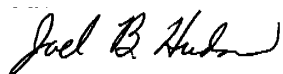

JOEL B. HUDSON

Administrative Assistant to the
Secretary of the Army

0320902

PETER J. SCHOOMAKER

General, United States Army

Chief of Staff

DISTRIBUTION

To be distributed in accordance with Initial Distribution Number (IDN), requirements for TM 55-1520-240-23-11.

WARNING AND FIRST AID DATA.

For artificial respiration and other first aid data, refer to FM 21-11.

Personnel performing instructions involving operations, procedures, and practices which are included or implied in this technical manual shall observe the following instructions. Disregard of these warnings and precautionary information can cause serious injury, illness, death, or an aborted mission.

**WARNING**

An operating procedure, practice, etc., which if not correctly followed, could result in personal injury or loss of life.

**CAUTION**

An operation procedure, practice, etc., which if not strictly observed, could result in damage to or destruction of equipment.

NOTE

An operating procedure, condition, etc., which is essential to highlight.

**WARNING**

Cleaning Solvents

Those areas of skin and clothing that come in contact with cleaning solvents should be thoroughly washed immediately.

Saturated clothing should be removed immediately.

Areas in which cleaning solvents are used should be adequately ventilated to keep vapors to a minimum.

If cleaning solvents contact the eyes, nose, or ears, flush them with generous quantities of water, and then seek medical attention immediately.

**WARNING**

Electrical and Electronic Equipment Maintenance

Do not wear rings, watches, or metal jewelry when working around electrical equipment. Serious burns can result.

Be careful when working on 150 and 300 vdc circuits and on ac generator 115 and 200 vac outputs. Serious burns can result.

WARNING

Dangerous Static Charges

Ground the helicopter during parking, fueling, or defueling. Sparks can cause fuel vapor to ignite.

WARNING

Dangerous Voltages at Antenna Terminals

Be careful when working near antenna or antenna terminals. Radio frequency (rf) voltages exist at those points when transmitters are operating. Contact with radiating antennas can cause serious rf burns.

WARNING

Poisonous Carbon Monoxide Fumes

Toxic carbon monoxide fumes may be present inside the helicopter whenever engines or APU are operating with cargo ramp open. Ventilate the cockpit.

WARNING

Corrosive Battery Electrolyte (Potassium Hydroxide)

The electrolyte used in nickel-cadmium batteries contains potassium hydroxide which is a caustic substance.

Contact with skin or eyes will cause burns.

Use rubber gloves, rubber apron, and protective eye covering or face shield when handling battery.

If personal contact with electrolyte occurs, flush immediately with large amounts of only clean water. Get medical attention immediately.

WARNING

Explosive Battery Hazard

Before removing or installing battery, make sure battery switch is OFF and battery has cooled down if overheated.

Connecting or disconnecting battery connector while battery is under load may cause explosion or electrical arcing resulting in injury to personnel.

WARNING

Electrolyte Contamination

Separate nickel cadmium batteries and lead-acid type batteries as far as possible from each other.

Do not let anything associated with a lead-acid battery, including air, come in contact with a nickel-cadmium battery or its electrolyte. Sulfuric acid fumes from a lead-acid battery could result in damage to a nickel-cadmium battery leading to battery failure and a hazard to personnel.

Do not use same tools or protective clothing for both types of batteries.

If sulfuric acid has been somehow mixed with electrolyte in the battery, the upper areas of the battery cells will appear green in color indicating battery failure or damage and potential danger to personnel unless replaced.

WARNING

Acids and Alkalines

Do not add water to acid. A violent action will result. Add acid to water in small quantities.

Rust stripper is an alkaline solution.

Avoid skin contact. Wear protective clothing. Wash thoroughly after using.

WARNING

Windshield Rain Repellent

Do not let windshield rain repellent contact open flame. Deadly hydrogen fluoride gas could be generated.

Wash hands with soap and water after handling repellent.

WARNING

Antiseize Compounds

Some antiseize compounds are irritants. Avoid inhaling fumes and contact with skin.

Wear protective clothing. Wash thoroughly after using.

WARNING

Paints, Varnishes, Dopes, Thinners, and Lubricants

These materials are generally highly flammable and may be irritants. Work in a well-ventilated area away from open flames.

Avoid inhaling fumes and prolonged contact with skin. Wash thoroughly after using.

WARNING

Epoxy Resins, Cements, and Adhesives

These materials may contain toxic or irritating substances. They may also be flammable. Work in a well-ventilated area away from open flames.

Wear protective clothing. Avoid contact with skin. Wash thoroughly after using.

WARNING

Radiation Hazard

Some instruments contain radioactive material. Do not try to disassemble these instruments. They present no radiation hazard unless seal is broken.

If you think seal is broken, do not remove instrument from helicopter before consulting Base Radioactive Protection Officer (AR 40-46).

Use a beta-gamma radiac meter AN/PDR-27 or equivalent to determine if instrument contains radioactive material (radium).

WARNING

Fire Extinguishing Agents

Monobromotrifluoromethane (CF_3Br) is highly volatile but is not easily detected by smell. It is not toxic, but reduces oxygen available for proper breathing.

If liquid CF_3Br contacts skin, it can cause frostbite or low temperature burns.

If agent touches eyes or skin, immediately flush affected area with running water. Get medical attention.

WARNING**Noise**

Sound pressure levels in this helicopter during some operating conditions exceed the Surgeon General's hearing conservation criteria (TB MED 501).

Hearing protection devices, such as aviator helmet or ear plugs, shall be worn by all personnel in and around the helicopter during operation.

WARNING**FOD**

Make sure area is clear of foreign objects before closing access doors, panels, and fairings.

If area is not clear, damage to components or systems could result in personal injury or death.

WARNING**JP-4/JP-5/JP-8 Fuel MIL-T-5624**

Fuel is flammable. Do not use near welding areas, open flames, or on very hot surfaces.

Use only with adequate ventilation.

Avoid prolonged or repeated contact with skin. Prolonged contact may cause drying and irritation of skin.

Remove saturated clothing immediately.

Do not smoke when handling fuel.

Do not take internally.

Store in approved, metal safety containers.

WARNING**Lubricating Oils MIL-L-23699 or MIL-L-7808**

If oil is decomposed by heat, toxic gases are released.

Prolonged contact with liquid or mist may cause dermatitis and irritation.

If there is prolonged contact with skin, wash affected area with soap and water. If oil contacts eyes, flush with water immediately. Remove saturated clothing.

If swallowed, do not try to vomit. Seek immediate medical attention.

When handling liquid oil, wear rubber gloves. If prolonged contact with mist is likely, wear approved respirator.

WARNING

Lifting Components With Hoist

Lifting or hoisting of components shall only be done by designated personnel.

The load capacity rating shall be clearly marked on hoist. Do not exceed load rating.

Inspection and testing for cracks or defects in hoist system shall be performed on a regular basis.

Before lifting, alert personnel in immediate areas.

Before lifting, balance the load.

Do not stand under load while it is being moved from one area to another on a hoist.

Do not stand under load to do maintenance work.

When positioning or stowing the cargo hook, do not grasp the hook assembly by the synchronizing assembly shaft. Serious injury can result. The strap handle is to be used when positioning or stowing the hook.

WARNING

Hydraulic Pressures

High pressures used in testing hydraulic components can cause line rupture or component failure.

Only qualified personnel shall operate, service, and maintain hydraulic test equipment.

Use heavy plastic shielding at least 5/8 inch thick when applying pressures over 250 psi to prevent injury to personnel.

WARNING

Hydraulic Fluid

Hydraulic fluid is toxic. It can irritate skin and eyes and cause burns. When fluid is decomposed by heating, it releases toxic gases.

Avoid inhaling. Use only with adequate ventilation. If prolonged contact with mist is likely, wear an appropriate respirator.

Avoid contact with skin, eyes, or clothing. Wear rubber gloves if handling liquid.

In case of contact with the skin, immediately wash skin with soap and water. In case of contact with eyes, flush them immediately with clear water and get medical attention.

If liquid is swallowed, do not induce vomiting; get immediate medical attention.

WARNING

Compressed Air

Do not use more than 30 psi compressed air for cleaning purposes. Debris propelled under pressure can cause injury to eyes.

Use eye protection to prevent injury to personnel.

WARNING

Flare Dispenser

Flares can accidentally fire, sometimes from stray voltage. Injury or death can result.

Remove all electrical power from helicopter before installing loaded payload module on dispenser assembly.

Keep hands and face away from end of payload module during installation.

WARNING

Maintenance Platforms/Workstands

Use only appropriate maintenance platforms/workstands illustrated in TM 55-405-10, or other approved locally procured stands and restraint equipment, when working above 10 feet on helicopters in a nontactical environment. Otherwise, personnel injury could result from accidental falls.

WARNING

Black Light Inspection Eyewear

Do not wear eyeglasses having light sensitive lenses while performing magnetic particle (black light) or fluorescent penetrant inspections.

Such lenses have a 16 to 45 percent light transmission loss.

Wearing them can result in failure to detect flaws and cracks under ultraviolet light.

WARNING

Cadmium-Plated Tools

Use only chrome-plated or unplated steel tools when working on the helicopter.

Cadmium or zinc-plated tools are not permitted, since these platings are prone to chipping and flaking. The chips and flakes could cause corrosion or fluid contamination.

All tools, regardless of plating type, shall be serviceable and free of chipping.

LIST OF EFFECTIVE PAGES

Insert latest changed pages; dispose of superseded pages in accordance with regulations.

NOTE: On a changed page, the portion of the text affected by the latest change is indicated by a vertical line, or other change symbol, in the outer margin of the page. Changes to illustrations are indicated by miniature pointing hands. Changes to wiring diagrams are indicated by shaded areas.

Dates of issue for original and changed pages are:

Original	19 September 2002
Change 1	30 September 2003

Page No.	*Change No.	Page No.	*Change No.
Title	0	H-2 blank	0
a through g	0	I-1	0
h blank	0	I-2 blank	0
A	1	J-1	0
B blank	1	Glossary-1 – Glossary-6 .	1
i	1	Glossary-7	0
ii blank	1	Glossary-8 blank	0
17-1 – 17-3	0	Index-1 – Index-9	1
17-4 blank	0	Index-10	0
17-5 – 17-28	0	Index-11 – Index-15	1
A-1	0	Index-16	0
A-2 and A-3	1	Index-17 – Index-38	1
A-4	0	Index-38.1 added	1
B-1 – B-78	0	Index-38.2 added	1
B-79 and B-80	1	Index-39 – Index-43	1
B-81 – B-87	0	Index-44	0
B-88 – B-93	1	Index-45 – Index-56	1
B-94	0	Index-56.1 added	1
C-1	0	Index-56.2 added	1
C-2 blank	0	Index-56.3 added	1
D-1	0	Index-56.4 added	1
D-2 blank	0	Index-56.5	1
E-1 – E-36	0	Index-56.6 added	1
E-37	1	Index-57 – Index-71	1
E-38 – E-129	0	Index-72	0
E-130	1	Index-73 – Index-80	1
E-131 – E-401	0	Index-81	0
E-402	1	Index-82 – Index-91	1
F-1	0	Index-92	0
F-2 blank	0	Index-93 – Index-153	1
G-1 – G-42	0	Index-154 blank	1
H-1	0		

*Zero in this column indicates an original page.

**AVIATION UNIT AND AVIATION
INTERMEDIATE MAINTENANCE MANUAL
CH-47D HELICOPTER**

REPORTING ERRORS AND RECOMMENDING IMPROVEMENTS

You can improve this manual. If you find any mistakes or if you know of a way to improve these procedures, please let us know. Mail your letter or DA Form 2028 (Recommended Changes to Publications and Blank Forms) located in the back of this manual, directly to: Commander, U.S. Army Aviation and Missile Command, ATTN: AMSAM-MMC-MA-NP, Redstone Arsenal, AL 35898-5000. A reply will be furnished to you. You may also provide DA Form 2028 information to AMCOM via e-mail, fax, or the World Wide Web. Our fax number is: DSN 788-6546 or Commercial 256-842-6546. Our e-mail address is: 2028@redstone.army.mil. Instructions for sending an electronic 2028 may be found at the back of this manual immediately preceding the hard copy 2028. For the World Wide Web use: <https://amcom2028.redstone.army.mil>.

DISTRIBUTION STATEMENT A: Approved for public release; distribution is unlimited.

TABLE OF CONTENTS

		PAGE NO.
VOLUME	XI	
CHAPTER	17	EMERGENCY EQUIPMENT 17-1
Section	I	Emergency Equipment Description and Operation 17-1
Section	II	Emergency Equipment 17-5
APPENDIX	A	References A-1
APPENDIX	B	Maintenance Allocation Chart B-1
APPENDIX	C	Aircraft Inventory C-1
APPENDIX	D	Expendable Supplies and Materials D-1
APPENDIX	E	Illustrated Fields Manufactured Items List E-1
APPENDIX	F	Wiring Diagrams F-1
APPENDIX	G	Weight and Balance G-1
APPENDIX	H	Storage of Aircraft H-1
APPENDIX	J	Torque Limits J-1
APPENDIX	K	Marking Information K-1
GLOSSARY	 Glossary-1
INDEX	 Index-1

*This manual together with TM 55-1520-240-23-1, TM 55-1520-240-23-2, TM 55-1520-240-23-3, TM 55-1520-240-23-4, TM 55-1520-240-23-5, TM 55-1520-240-23-6, TM 55-1520-240-23-7, TM 55-1520-240-23-8, TM 55-1520-240-23-9, TM 55-1520-240-23-10, supersedes TM 55-1520-240-23-1, TM 55-1520-240-23-2, TM 55-1520-240-23-3, TM 55-1520-240-23-4, TM 55-1520-240-23-5, TM 55-1520-240-23-7, TM 55-1520-240-23-8, TM 55-1520-240-23-9, TM 55-1520-240-23-10, 10 May 1983, and TM 55-1520-240-23-6, 6 May 1983, including all changes.

CHAPTER 17

EMERGENCY EQUIPMENT

SECTION I

EMERGENCY EQUIPMENT DESCRIPTION AND OPERATION

Emergency equipment consists of first aid kits, an ax, portable fire extinguishers, and an emergency exit lighting system.

There are seven first aid kits; one in the passageway and six in the cabin, three on each side. The ax is for emergency escapes. It is located near the cabin door about sta. 200.

There are three portable fire extinguishers; one is mounted on the cockpit floor to the right of pilot's seat, one at the forward end of cabin, and one in the ramp area. For description and operation, refer to TB 5-4200-200-10.

The emergency exit lighting system consists of three lights, an inertia switch, and a control switch on overhead panel. There is an exit light above the ramp, one by the cabin door, and one over cabin escape hatch. These lights can be turned on, off, or charged by operating the switch in the cockpit. The inertia switch will also cause the lights to come on if a hard landing in excess of **3g** occurs. The lights have rechargeable internal batteries so they are portable. The lights can be removed by grasping handle and pulling. When the handle is down, the light is on; when the handle is up the light is off.

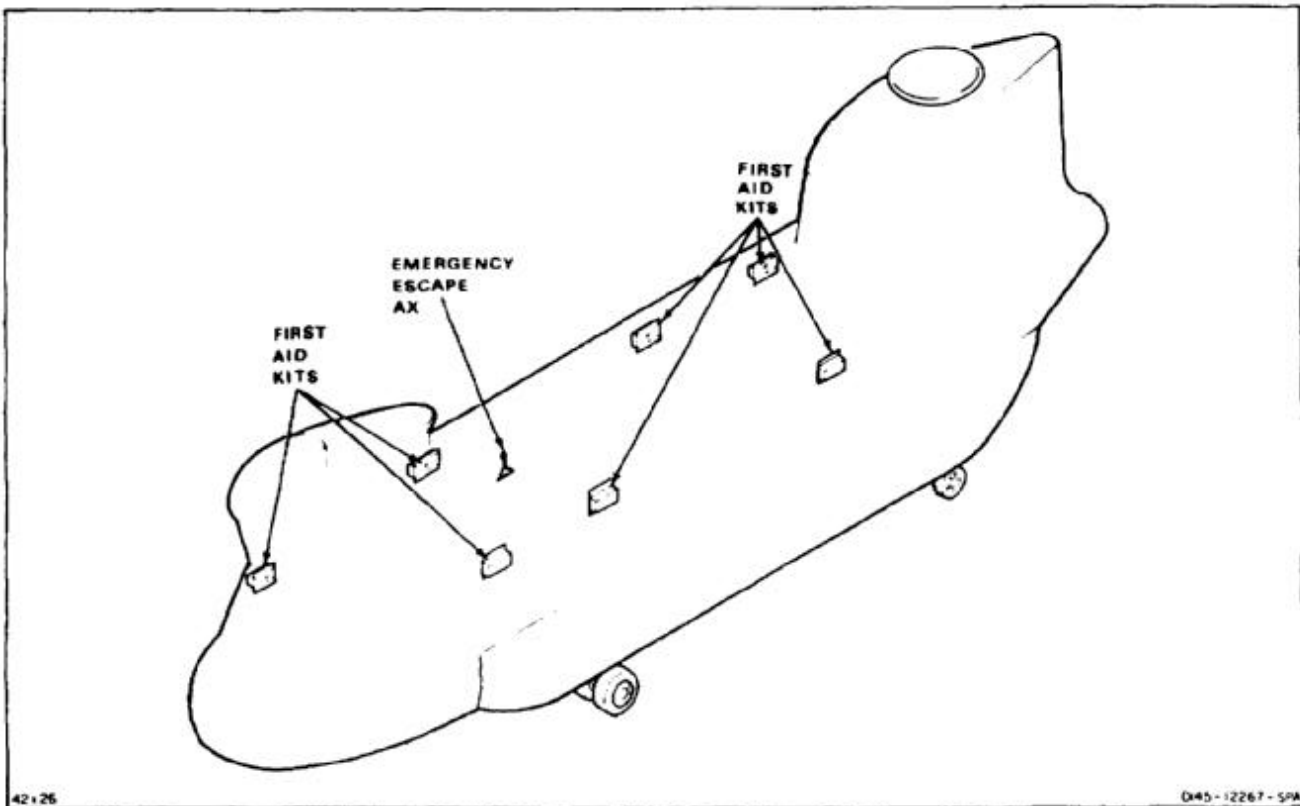

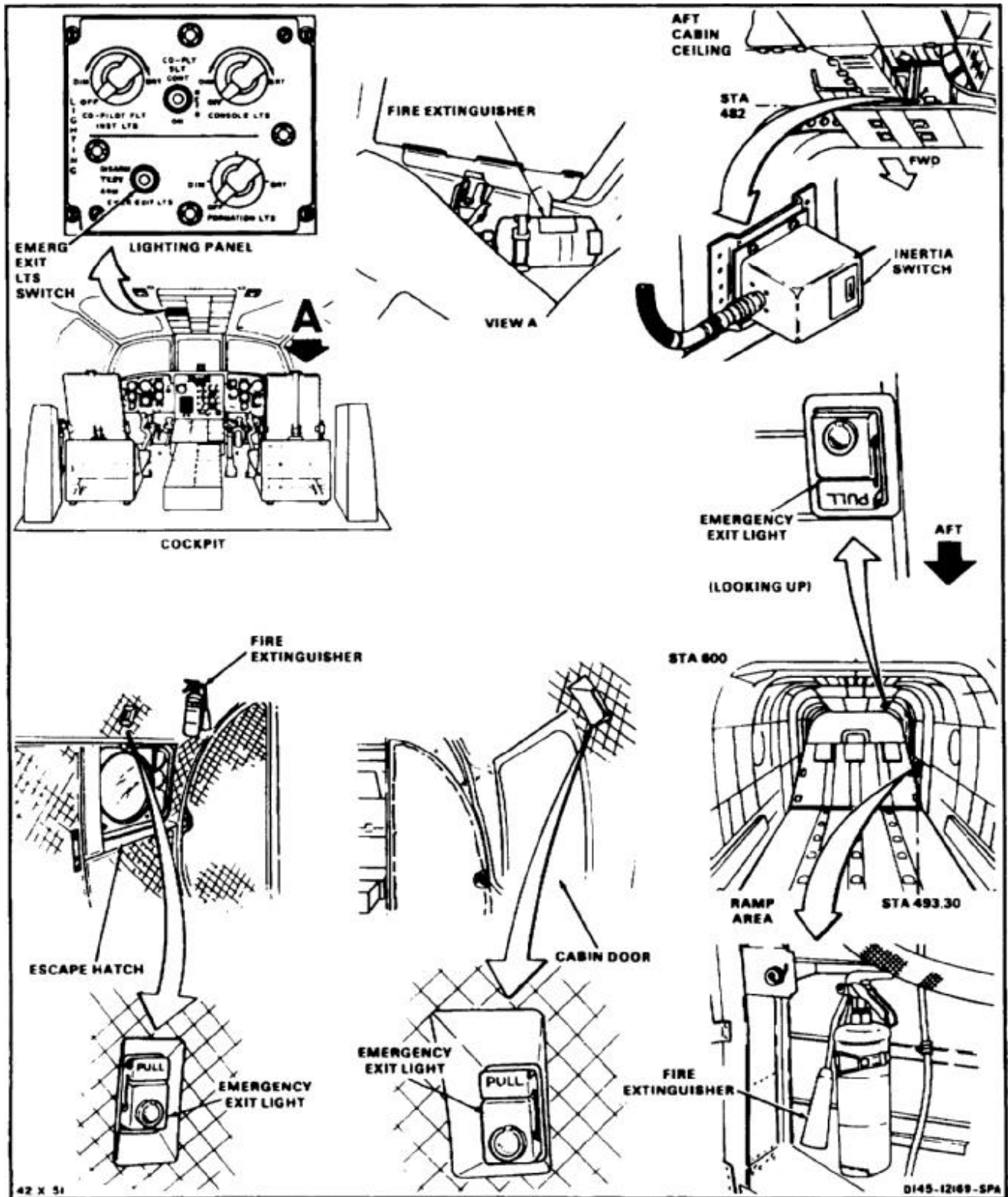

END OF TASK

SECTION II EMERGENCY EQUIPMENT

INITIAL SETUP

Applicable Configurations:

All

Tools:

Aircraft Mechanic's Tool Kit, NSN 5180-00-323-4692

Materials:

None

Personnel Required:

Medium Helicopter Repairer

Equipment Condition:

Battery Disconnected (Task 1-39)

Electrical Power Off

Hydraulic Power Off

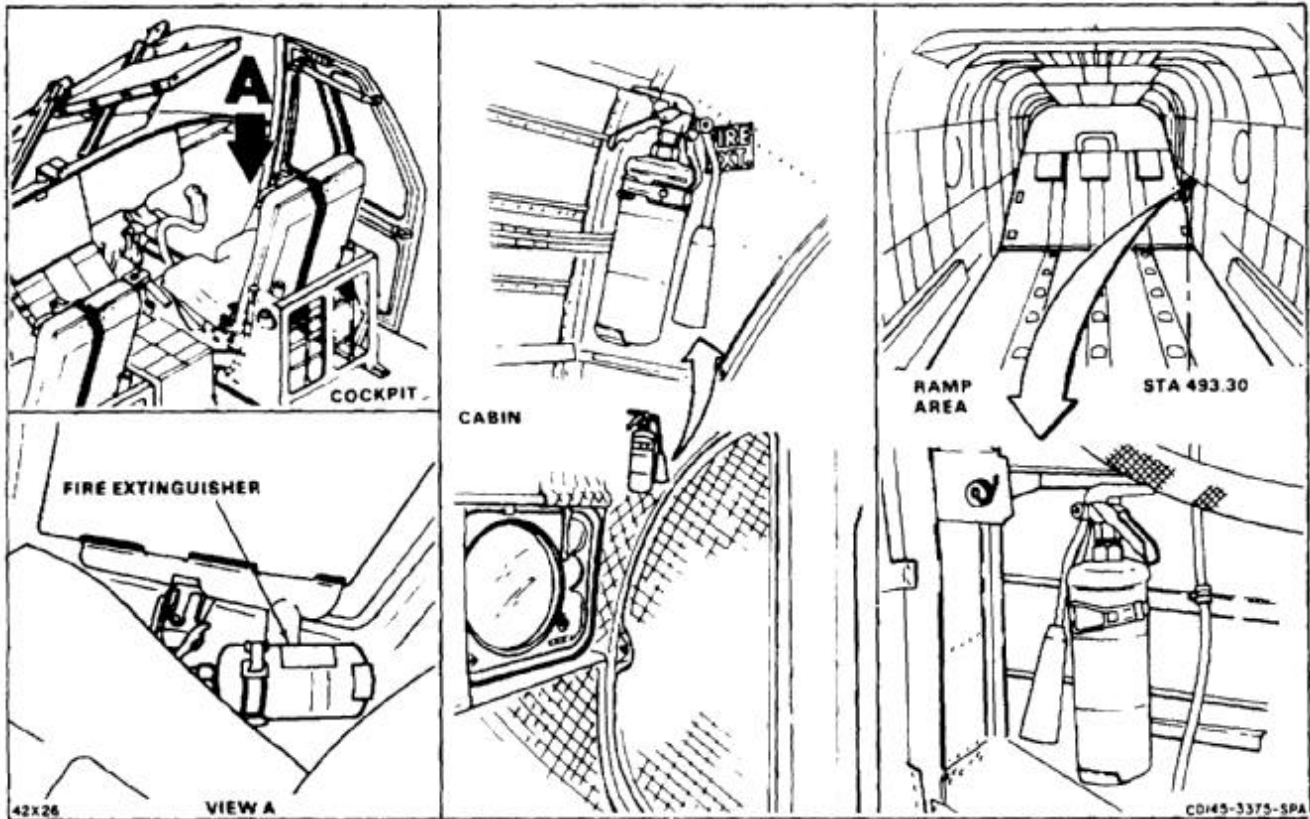

NOTE

There are three portable extinguishers; one is mounted on cockpit floor to right of pilot's seat, one at left forward end of cabin, and one at left side of ramp area. Procedure is same to remove any extinguisher and bracket. Extinguisher in ramp area is shown here.

1. Unlock bracket (1) and remove extinguisher (2).

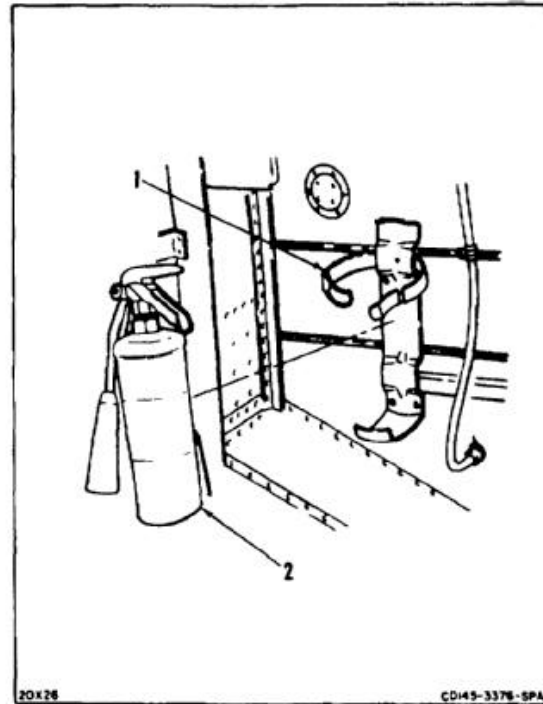

2. Remove four screws (3), washers (4), and bracket (1).

FOLLOW-ON MAINTENANCE:

None

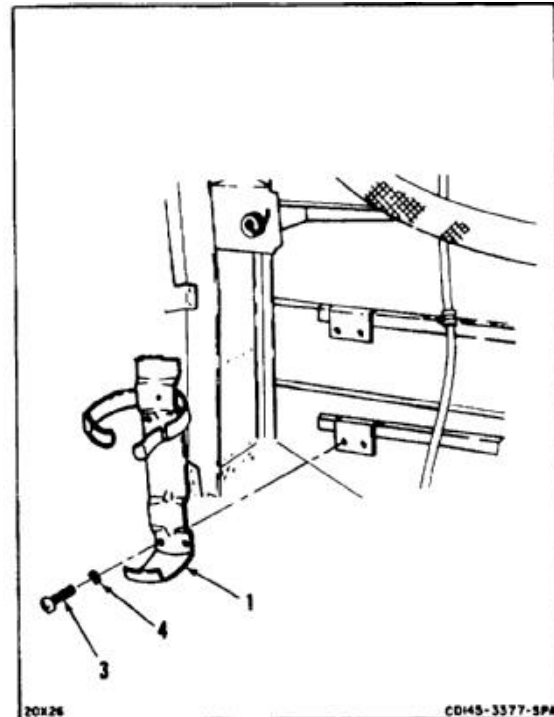

END OF TASK

INITIAL SETUP

Applicable Configurations:

All

Tools:

Aircraft Mechanic's Tool Kit, NSN 5180-00-323-4692

Materials:

None

Personnel Required:

Medium Helicopter Repairer
Inspector

References:

TM 55-1520-240-23P

Equipment Condition:

Fire Extinguisher Inspected (TM 1-1500-204-23)

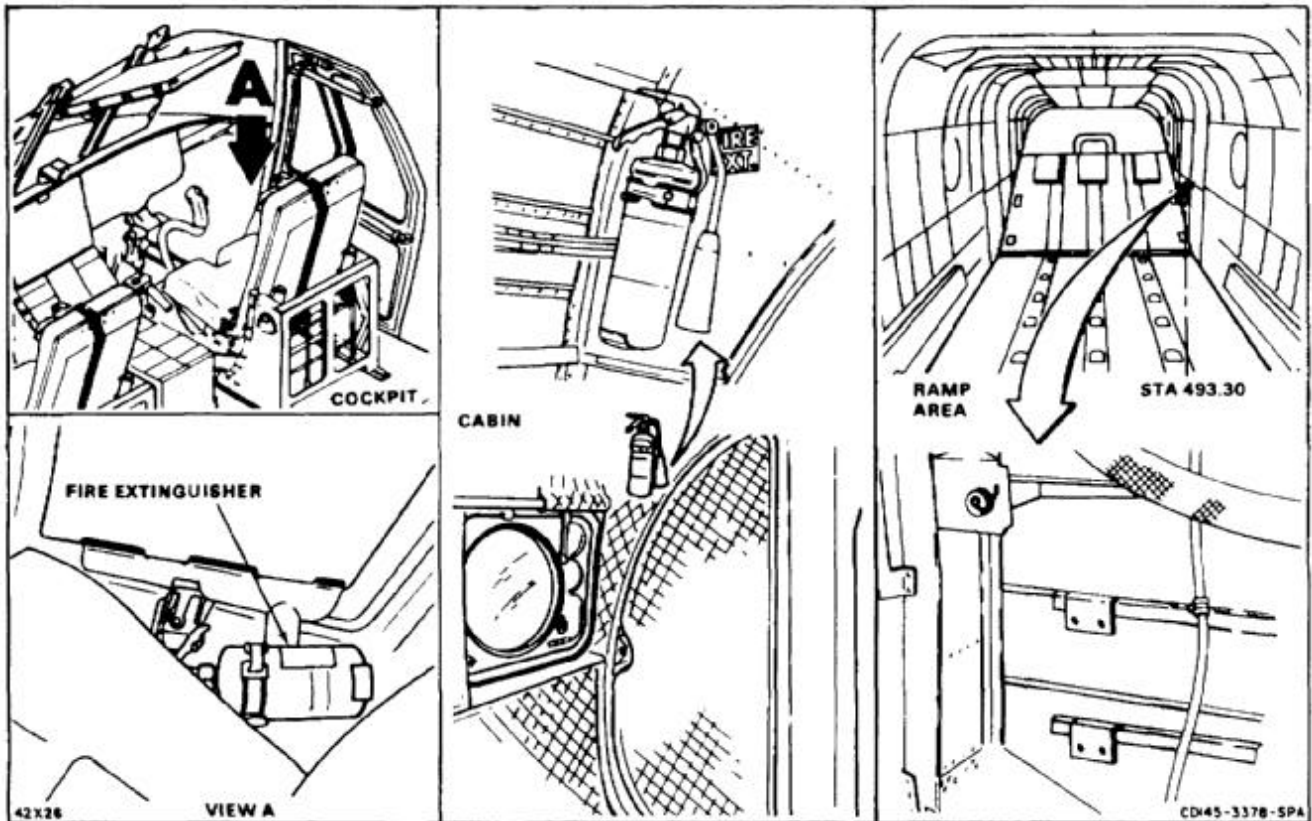

NOTE

There are three portable extinguishers; one is mounted on cockpit floor to right of pilot's seat, one at left forward end of cabin, and one at left side of ramp area. Procedure is same to install any extinguisher and bracket. Extinguisher in ramp area is shown here.

1. Position bracket (1) on structure (2). Align holes and install four screws (3) and washers (4).

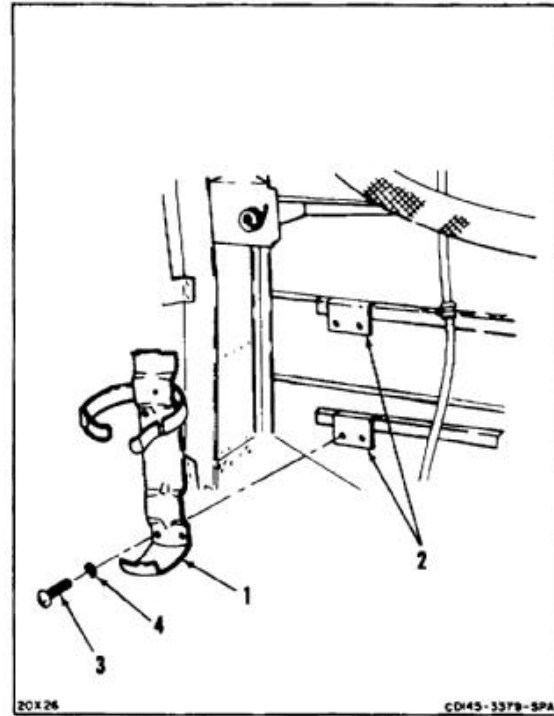

2. Position extinguisher (5) in bracket (1) and lock bracket.

INSPECT**FOLLOW-ON MAINTENANCE:**

None

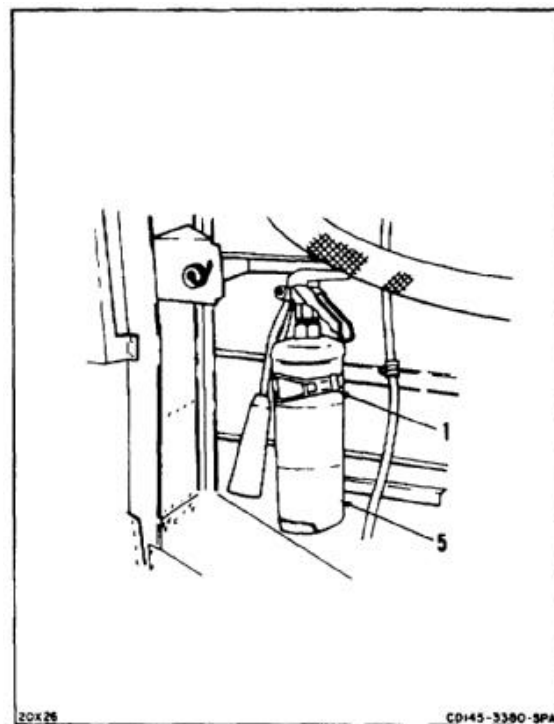

END OF TASK

INITIAL SETUP

Applicable Configurations:

All

Tools:

Aircraft Mechanic's Tool Kit, NSN 5180-00-323-4692

Materials:

None

Personnel Required:

Medium Helicopter Repairer

Equipment Condition:

- Battery Disconnected (Task 1-39)
- Electrical Power Off
- EMER EXIT LTS Switch at Disarm
- Cargo Ramp Open and Level (TM 55-1520-240-T) (For Ramp Light)
- Left Ramp Extension Removed (Task 2-238) (For Ramp Light)
- Work Platform Installed in Maximum Left Position (Task 2-244) (For Ramp Light)

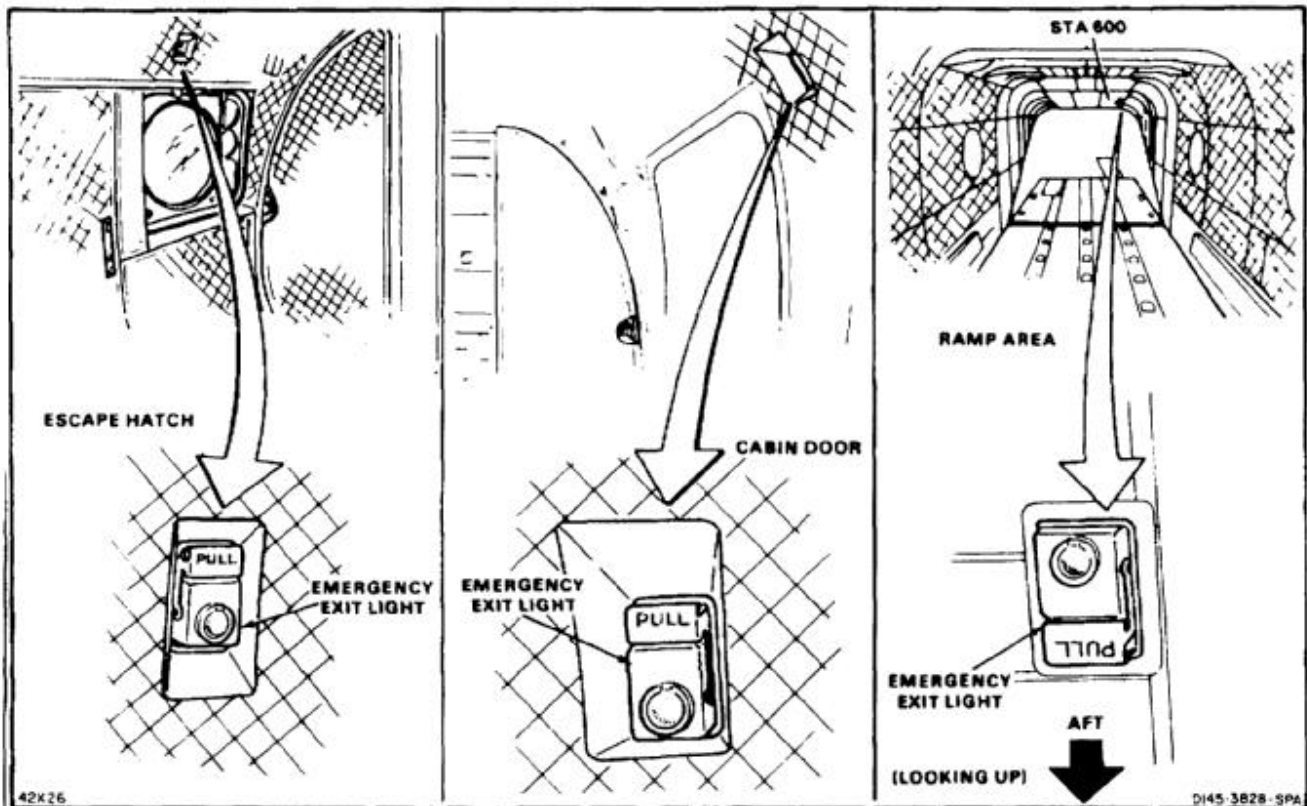

NOTE

Procedure is same to remove any exit light. Light above escape hatch is shown here.

1. Remove lockwire from bar (1) (handle). Pull bar down.

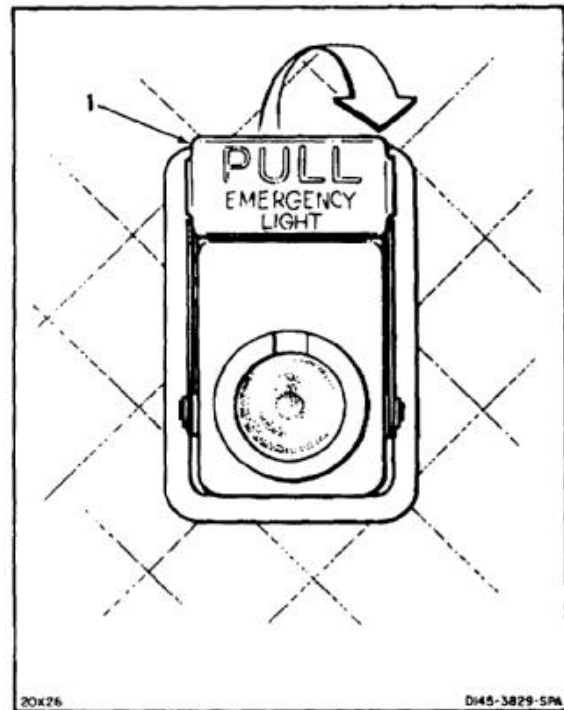

2. Remove light (2) from panel (3).

FOLLOW-ON MAINTENANCE:

None

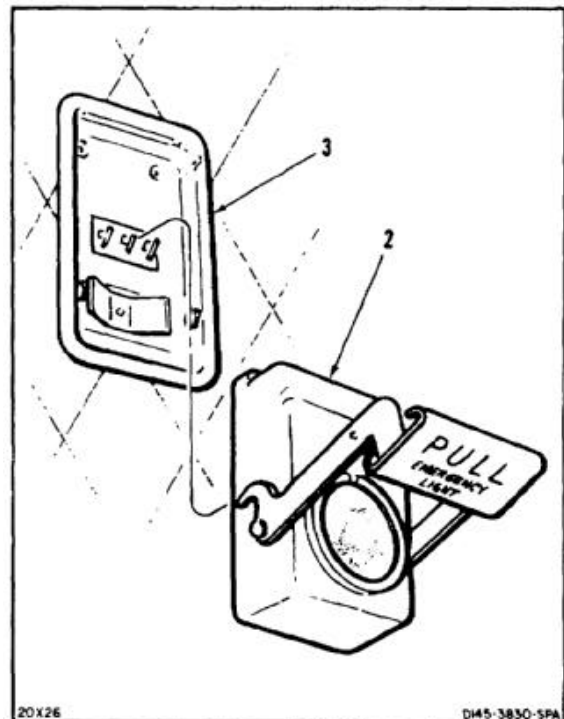

END OF TASK

INITIAL SETUP

Applicable Configurations:

All

Tools:

Electrical Repairer's Tool Kit, NSN 5180-00-323-4915
Soldering Iron

Materials:

None

Personnel Required:

Aircraft Electrician

Equipment Condition:

Off Helicopter Task

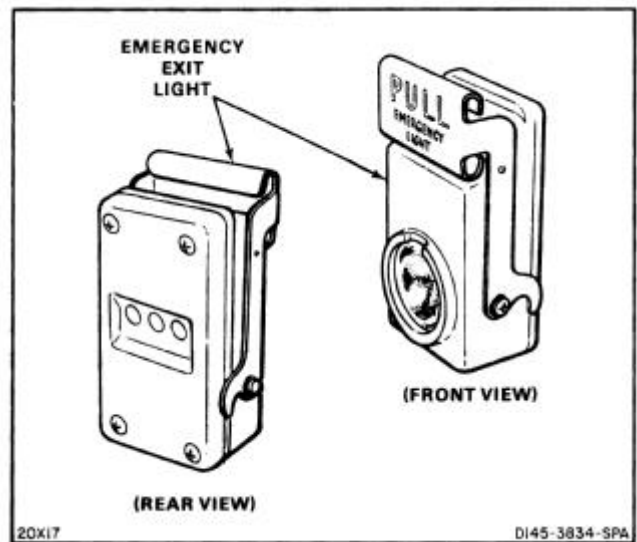

REMOVE HOUSING

1. Loosen four screws (1) in back of base (2). Separate base from housing (3).
2. Remove packing (4) from housing (3).

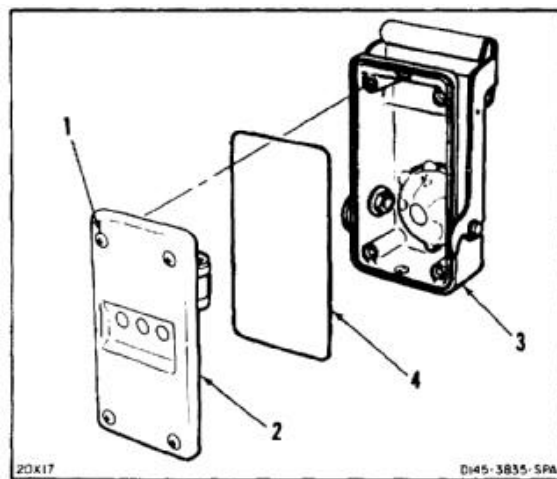

REMOVE BATTERIES

3. Remove screw (5) and clamp (6).
4. Remove two batteries (7) from base (2).

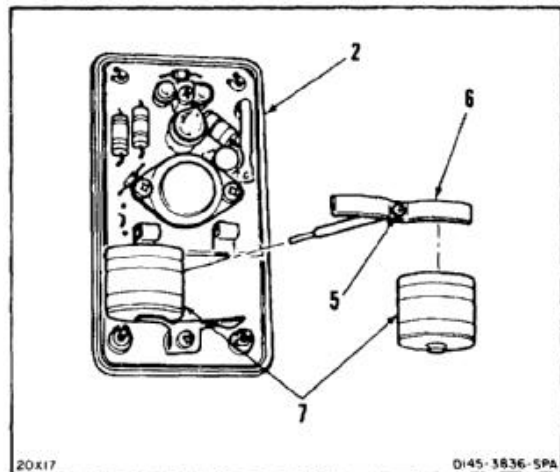

REMOVE LAMPS

5. Pull main lamp (8) from holder (9).
6. Remove screw (10), washer (11), and holder (12).
7. Push two lamps (13) from holder (12).

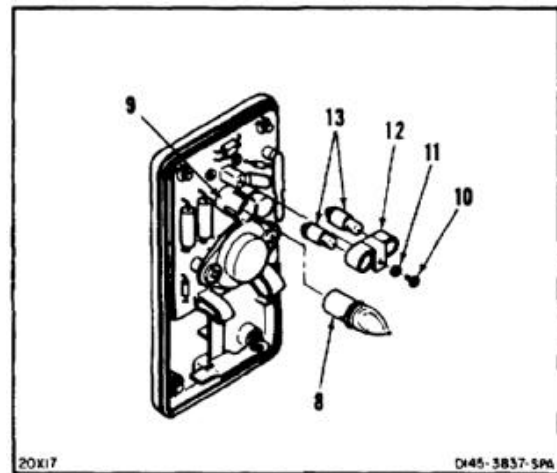
**REMOVE CIRCUIT BOARD**

8. Remove two retaining rings (14), screws (1), and four washers (15) from end of circuit board (16) in base (2).
9. Unsolder three contacts (17) and remove circuit board (16) from base (2).

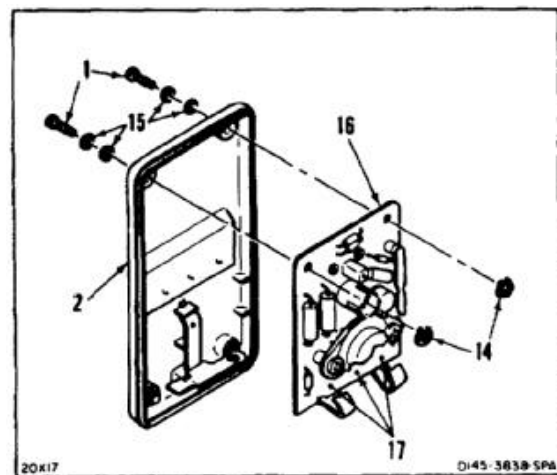
**DISASSEMBLE HOUSING**

10. Remove two screws (18) and washers (19).
11. Remove bar (handle) (20) from housing (3).

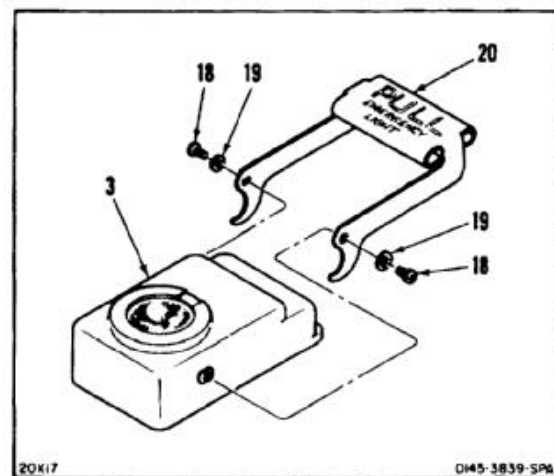

12. Heat three tabs (21) and remove reflector (22).
13. Push lens (23) from housing (3).

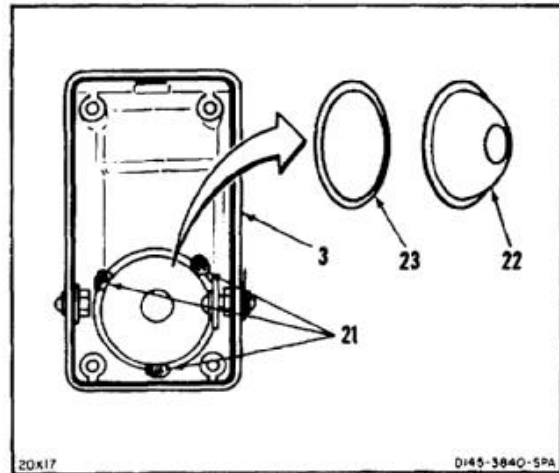

14. Remove nut (24), washer (25), and bushing (26).
15. Remove screw (27), washer (28), adapter (29), nut (30), and bushing (31).
16. Remove shaft (32) and packing (33) from bushing (31).

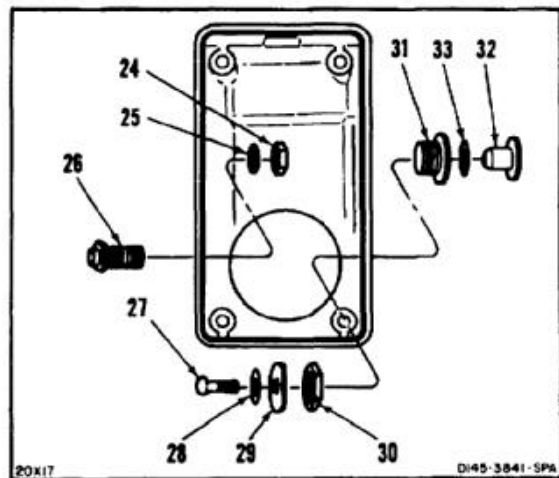

FOLLOW-ON MAINTENANCE:

None

END OF TASK

INITIAL SETUP

Applicable Configurations:

All

Tools:

Electrical Repairer's Tool Kit, NSN 5180-00-323-4915
Soldering Iron

Materials:

Adhesive (E33)
Sealant (E328)
Solder (E360)

Personnel Required:

Aircraft Electrician
Inspector

References:

TM 55-1520-240-23P

General Safety Instructions:

WARNING

Adhesive (E33) is toxic. It can irritate skin and cause burns. Avoid inhaling. Use only with adequate ventilation. Avoid contact with skin, eyes, or clothing. In case of contact, immediately flush skin or eyes with water for at least **15 minutes**. Get medical attention for eyes.

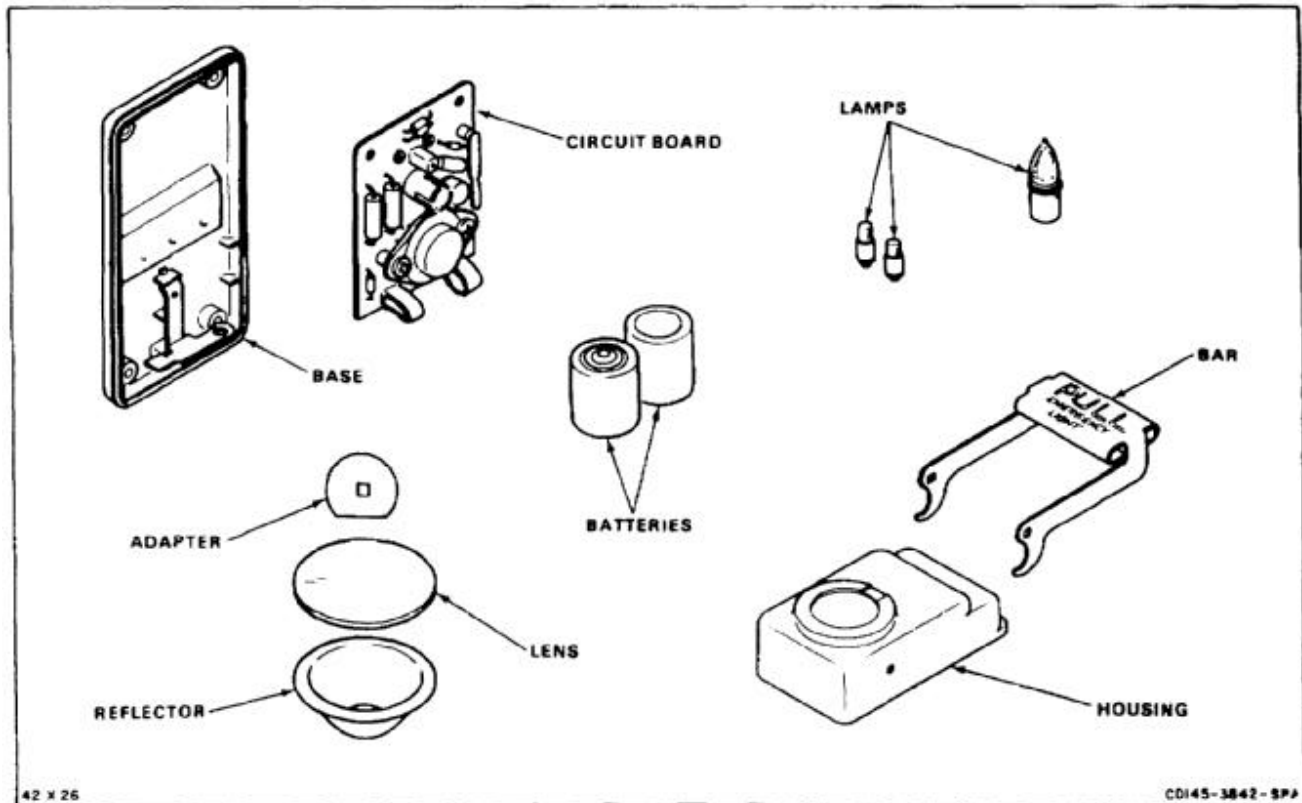

ASSEMBLE HOUSING

1. Apply small amount of sealant (E328) inside housing (1) around edge of hole (2).
2. Install bushing (3), washer (4), and nut (5).
3. Apply small amount of sealant (E328) under lip of bushing (6).
4. Install packing (7) in bushing (6). Install bushing in housing (1).
5. Slide shaft (8) through bushing (6) and install nut (9), adapter (10), washer (11), and screw (12).

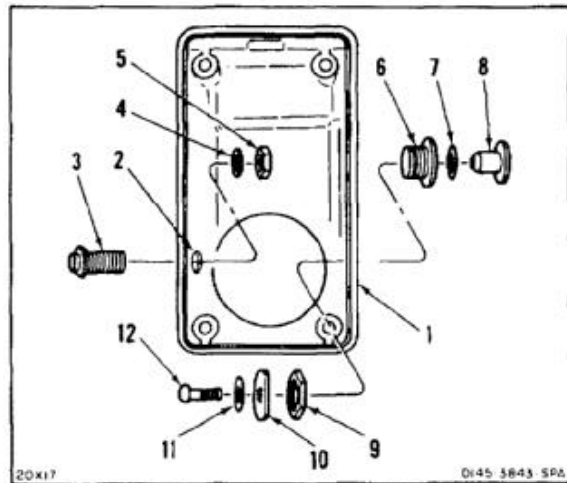

6. Apply adhesive (E33) around edge of lens mounting (13) inside housing (1).
7. Install lens (14), smooth side out.
8. Apply adhesive (E33) around edge of lens (14).
9. Install reflector (15) over lens (14).

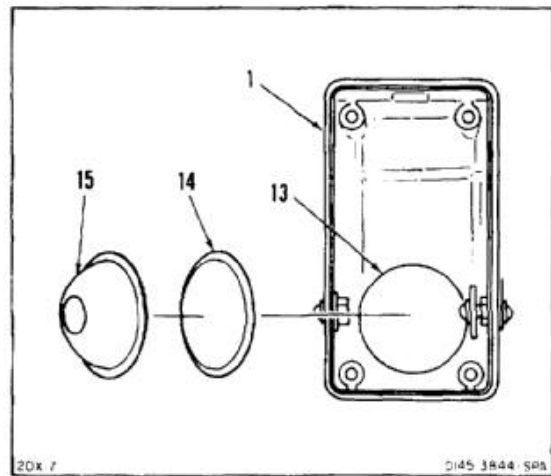

10. Heat three tabs (16) to hold reflector (15) to housing (1).

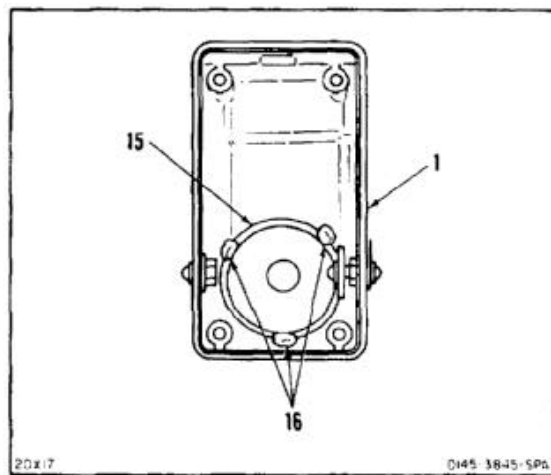

17-6 ASSEMBLE EMERGENCY EXIT LIGHT (Continued)

17-6

11. Position bar (handle) (17) on housing (1). With bar in closed position, flat side of adapter (10) shall be parallel to edge of housing (1).
12. Install two screws (18) and washers (19).

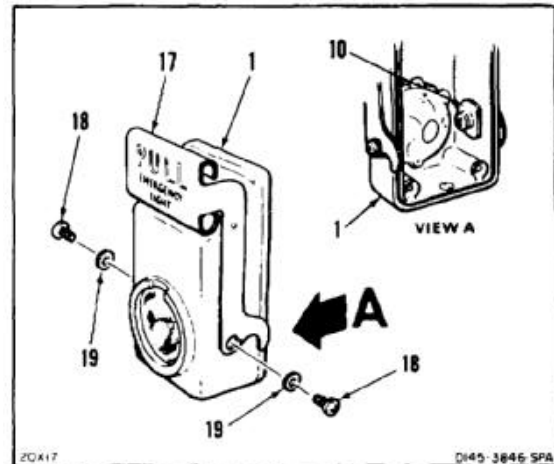
**INSTALL CIRCUIT BOARD**

13. Position circuit board (20) on base (21). Solder three contacts (22). Use solder (E360).
14. Install two screws (23), four washers (24), and two retaining rings (25).

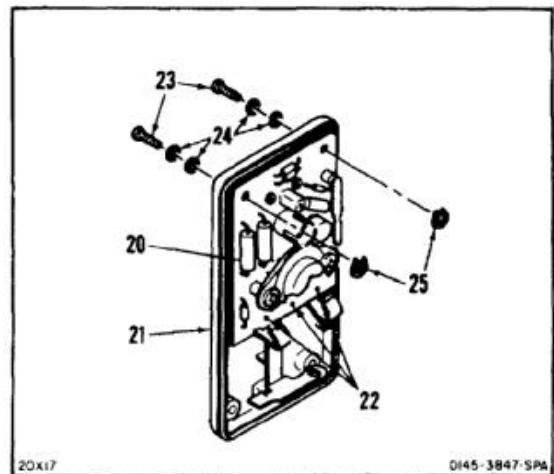
**INSTALL LAMPS**

15. Install two lamps (26) in holder (27).
16. Install holder (27), washer (28), and screw (29) in circuit board (20).
17. Install main lamp (30) in holder (31).

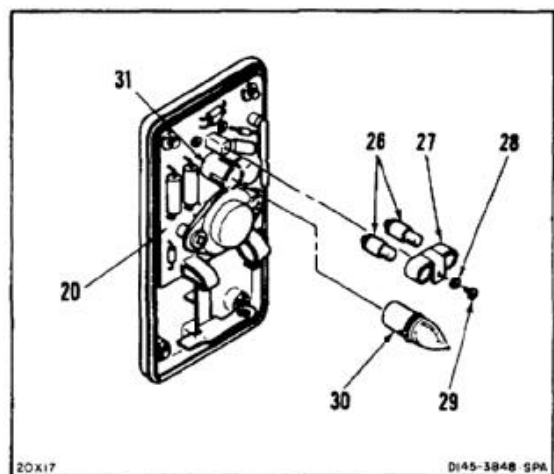

INSTALL BATTERIES

NOTE

Battery polarity is marked on base.

18. Install two batteries (32) in base (21).
19. Position clamp (33) over batteries (32) and tighten screw (34).
20. Push switch (35) to make contact with base (21). Check that main lamp (30) comes on. Release switch.

INSPECT

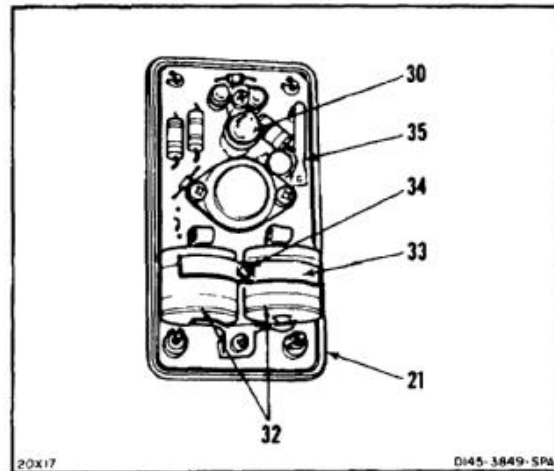

INSTALL HOUSING

21. Install packing (36) in housing (1).
22. Position housing (1) on base (21) and tighten four screws (23).

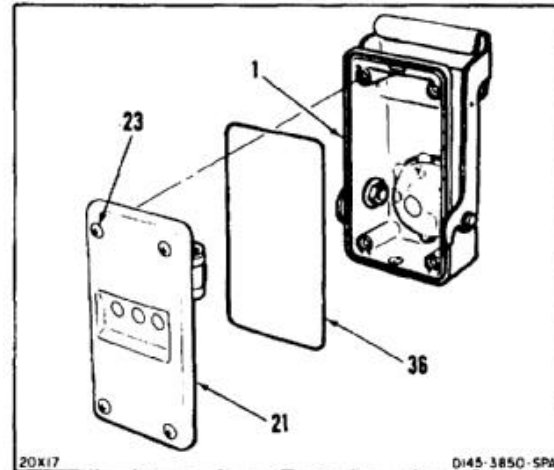

CHECK LIGHT

23. Pull bar (17) down. Check light (37). Light shall come on.
24. Close bar (17). Check light (37). Light shall go out.

INSPECT

FOLLOW-ON MAINTENANCE:

None

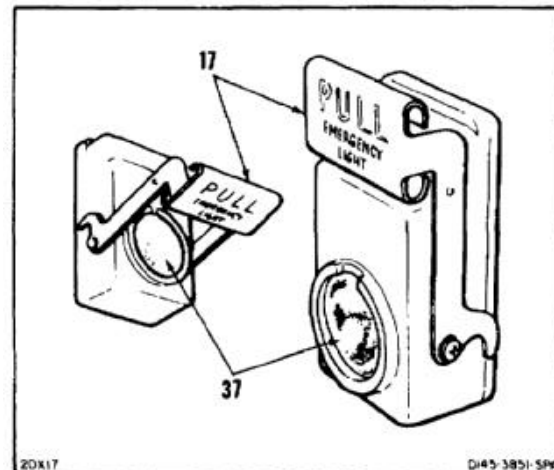

END OF TASK

INITIAL SETUP

Applicable Configurations:

All

Tools:

- Electrical Repairer's Tool Kit, NSN 5180-00-323-4915
- Power Supply, 28 VDC
- Toggle Switch, MS24523-21
- Exit Light Panel

Materials:

None

Personnel Required:

- Aircraft Electrician
- Inspector

Equipment Condition:

- Off Helicopter Task
- Charge Setup

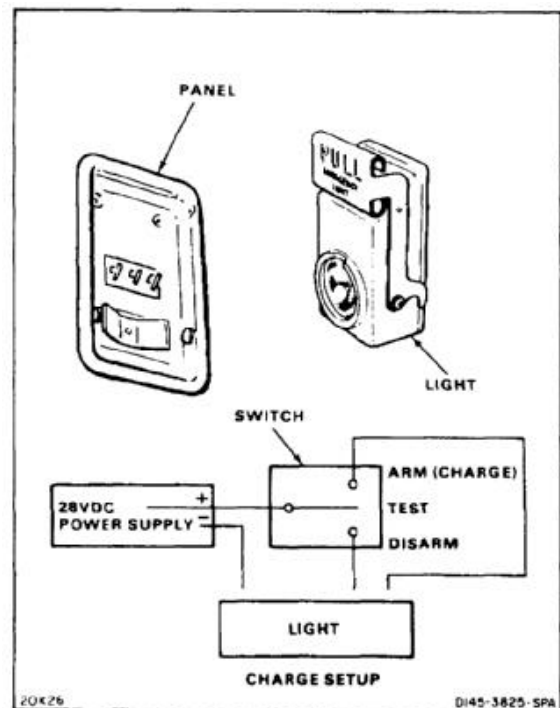

1. Install light (1) in panel (2).

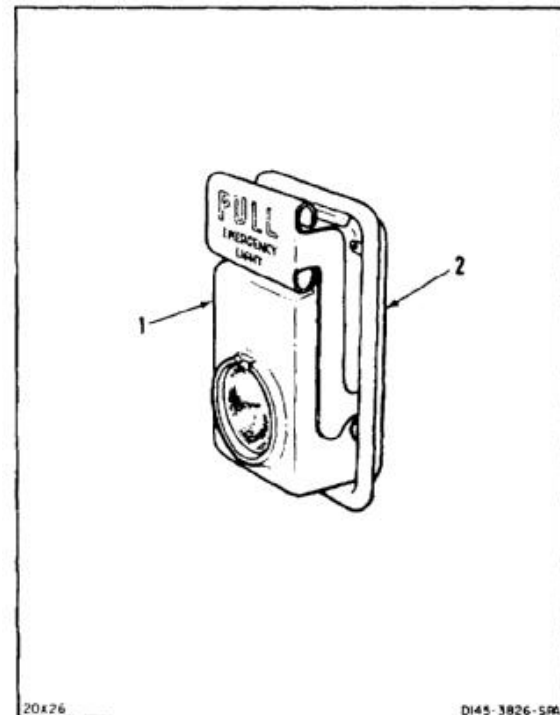

2. Connect panel (2) to switch (3) and power supply (4).

NOTE

Two small lamps inside light come on during battery charging. Glow of lamps can be seen through two pinholes in reflector.

3. Set switch (3) to TEST. Turn on power supply (4) and adjust output to **28 vdc**.
4. Check light (1). Main lamp (5) shall be out and pinholes (6) shall not be lit.
5. Set switch (3) to ARM (CHARGE). Pinholes (6) shall be lit. Let light (1) charge for **16 hours**.
6. Set switch (3) to TEST.
7. Check light (1). Main lamp (5) shall come on and pinholes (6) shall go out.
8. Set switch (3) to DISARM.
9. Check light (1). Main lamp (5) shall go out, pinholes (6) shall be lit.
10. Shut down power supply (4). Disconnect panel (2) from switch (3) and power supply.

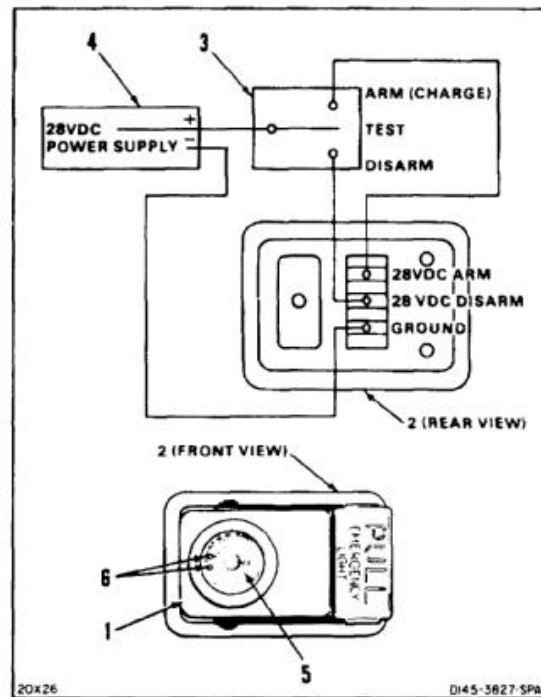
**INSPECT****FOLLOW-ON MAINTENANCE:**

None

END OF TASK

INITIAL SETUP

Applicable Configurations:

All

Tools:

Aircraft Mechanic's Tool Kit, NSN 51 80-00-323-4692

Materials:

Lockwire (E228)

Personnel Required:

Medium Helicopter Repairer
Inspector

References:

TM 55-1520-240-23P

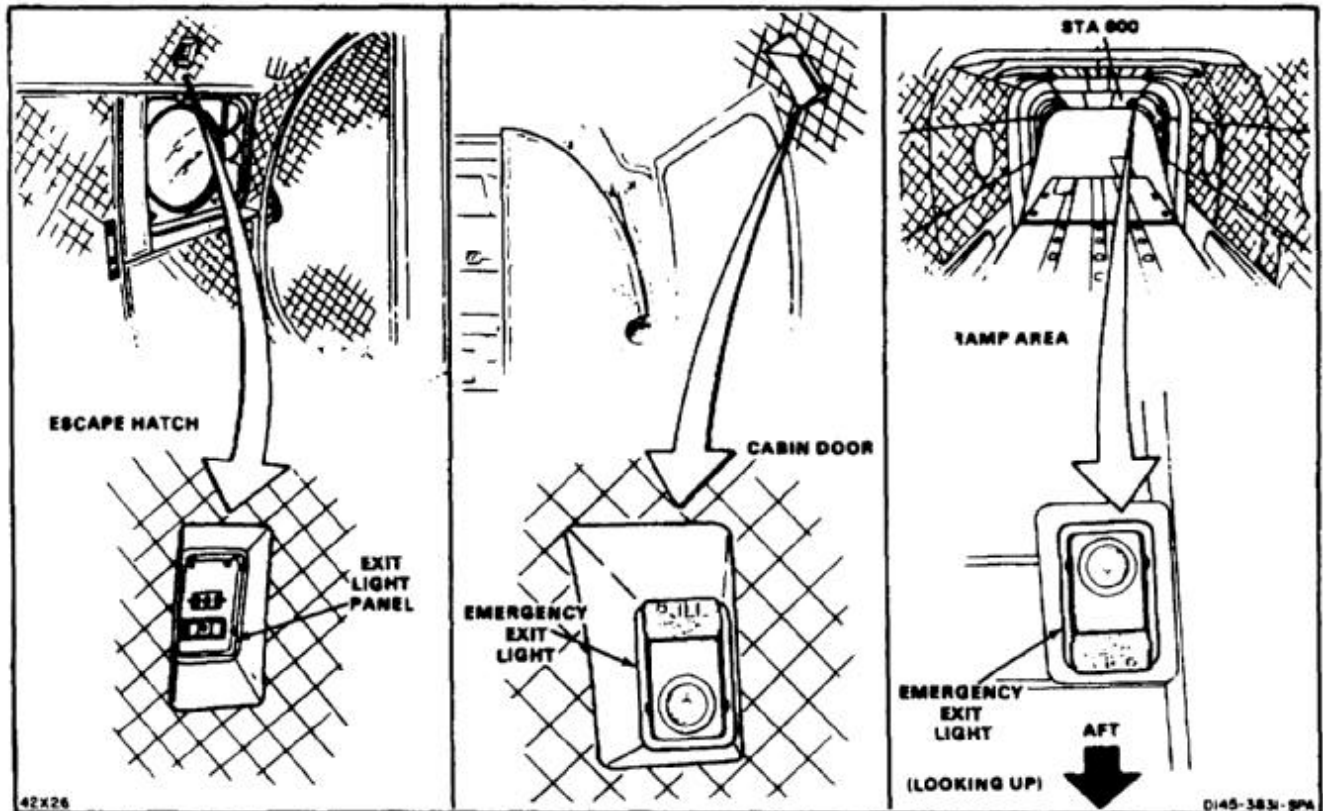

NOTE

Procedure is same to install any exit light. Light above escape hatch is shown here.

1. Position light (1) on panel (2) with light under lip (3) and both latches (4) engaged in pins (5).

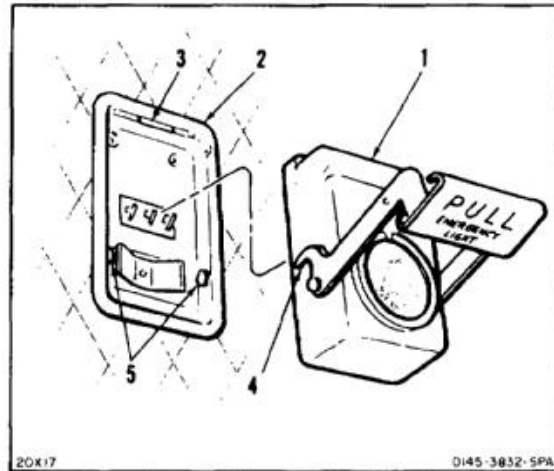

2. Push bar (6) (handle) up.
3. Lockwire bar (6) to tab (7). Use lockwire (E228).

INSPECT

FOLLOW-ON MAINTENANCE:

- Perform operational check (TM 55-1520-240-T).
- Stow work platform (Task 2-244) (for ramp light).
- Install left ramp extension (Task 2-244) (for ramp light).
- Close cargo ramp (Task 2-2) (for ramp light).

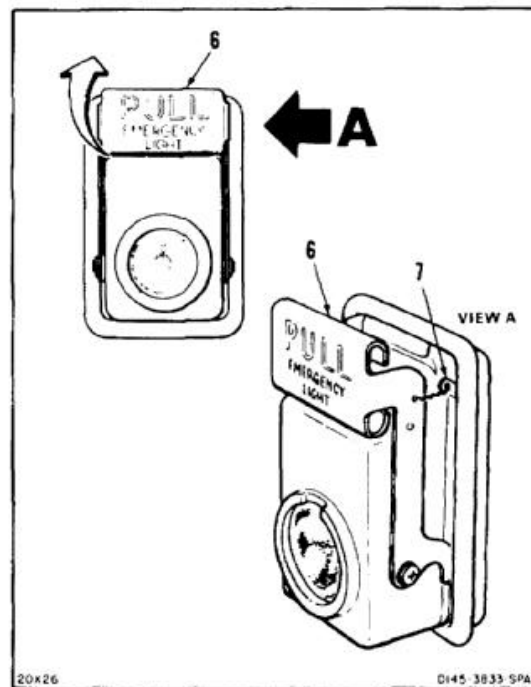

END OF TASK

INITIAL SETUP

Applicable Configurations:

All

Tools:

Aircraft Mechanic's Tool Kit, NSN 51 80-00-323-4692

Materials:

Paper Tags (E264)

Personnel Required:

Medium Helicopter Repairer

References:

Task 2-208

Equipment Condition:

- Battery Disconnected (Task 1-39)
- Electrical Power Off
- Emergency Exit Light Removed (17-4)
- Ramp Open and Level (Task 2-2) (For Ramp Panel)
- Left Ramp Extension Removed (Task 2-238) (For Ramp Panel)
- Work Platform Installed in Maximum Left Position (Task 2-244) (For Ramp Panel)

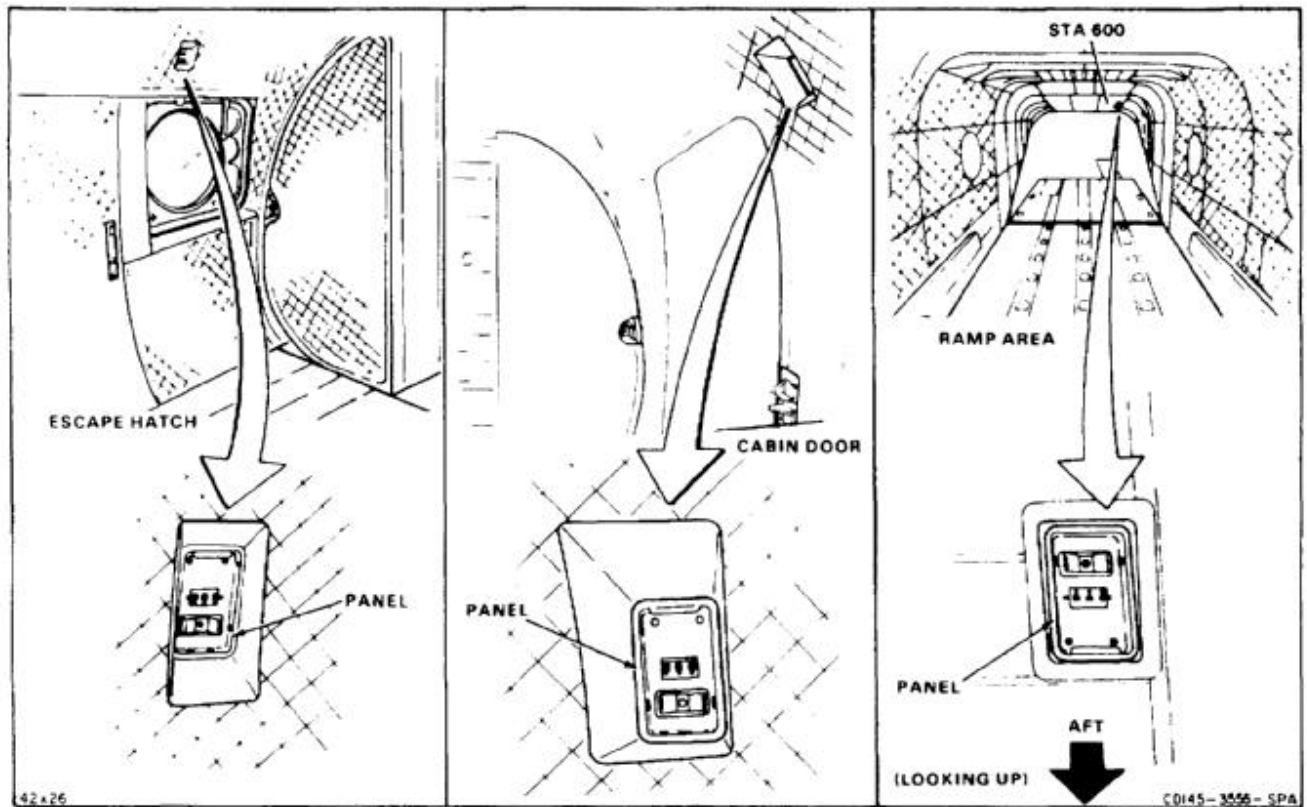

NOTE

Procedure is same to remove any exit light panel and pan. Panel and pan above escape hatch are shown here.

1. Remove blankets (1), if needed (Task 2-208).
2. Remove three screws (2) and washers (3).

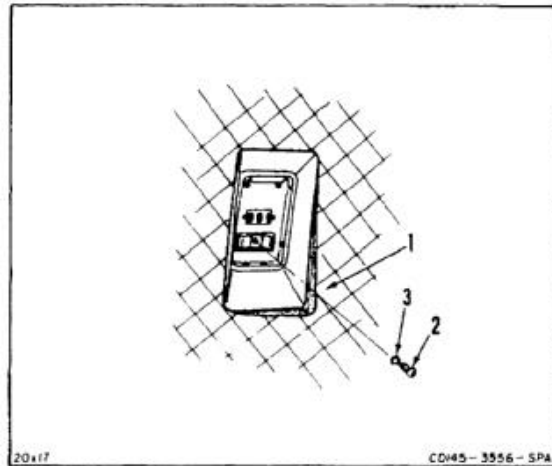

3. Tag (E264) and disconnect three wires (4) from back of panel (5) by removing screws (6) and washers (7). Loosen clamp (8), if needed.

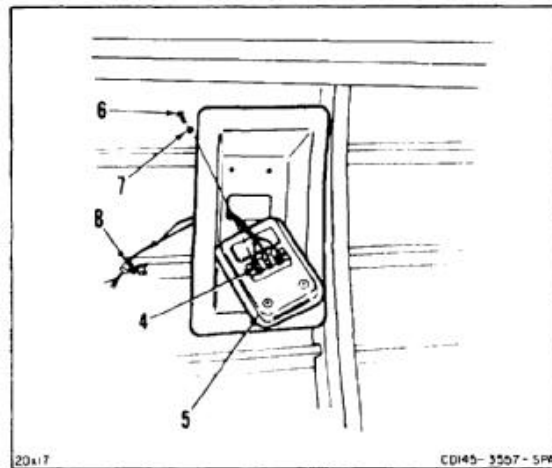

4. Remove panel (5) and pan (9).

FOLLOW-ON MAINTENANCE:

None

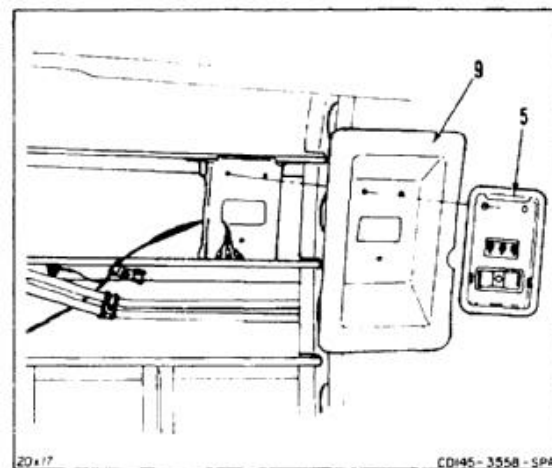

END OF TASK

INITIAL SETUP

Applicable Configurations:

All

Tools:

Aircraft Mechanic's Tool Kit, NSN 5180-00-323-4692

Materials:

None

Personnel Required:

Medium Helicopter Repairer

References:

TM 55-1520-240-23P
Task 2-210

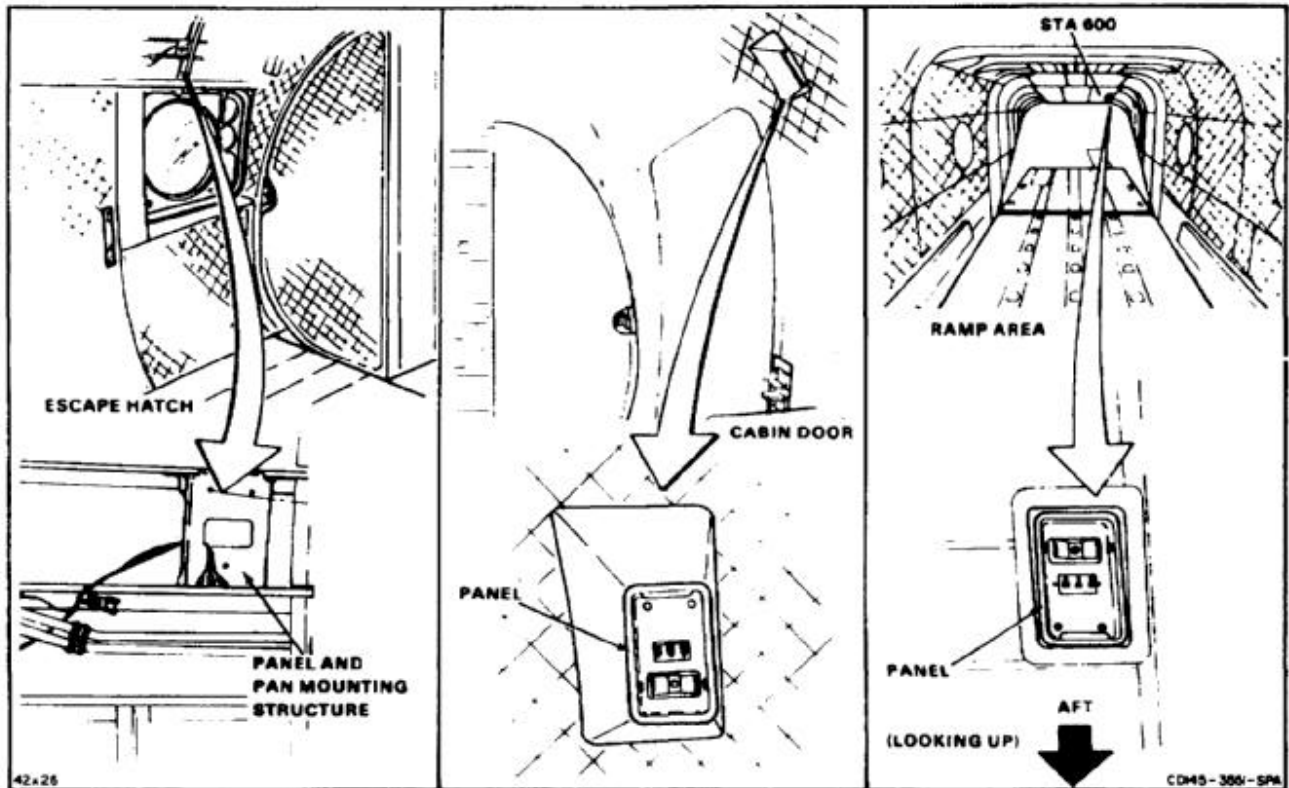

NOTE

Procedure is same to install any exit light panel and pan. Panel and pan above escape hatch are shown here.

1. Route wires (1) through pan (2). Connect three wires to back of panel (3) with screws (4) and washers (5). Remove tags.

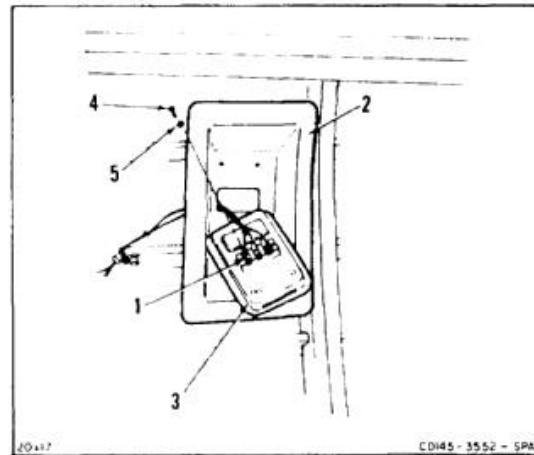

2. Position pan (2) and panel (3) on structure (6). Install three screws (7) and washers (8).
3. Tighten clamp (9), if loosened.

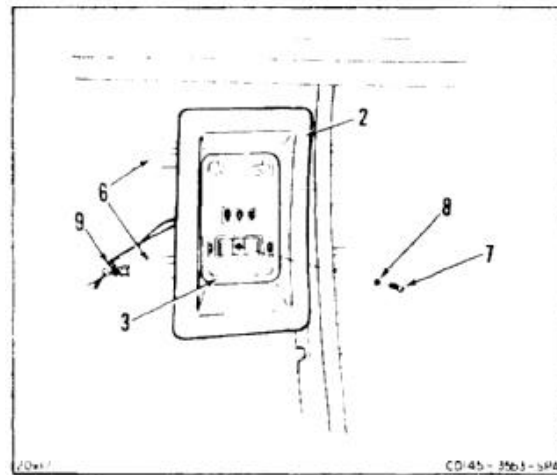

4. Install blankets (10) if removed (Task 2-210).

FOLLOW-ON MAINTENANCE:

Install emergency exit light (Task 17-8).
 Stow work platform (Task 2-244) (for ramp panel).
 Install left ramp extension (Task 2-244) (for ramp panel).
 Close ramp (Task 2-2) (for ramp panel).

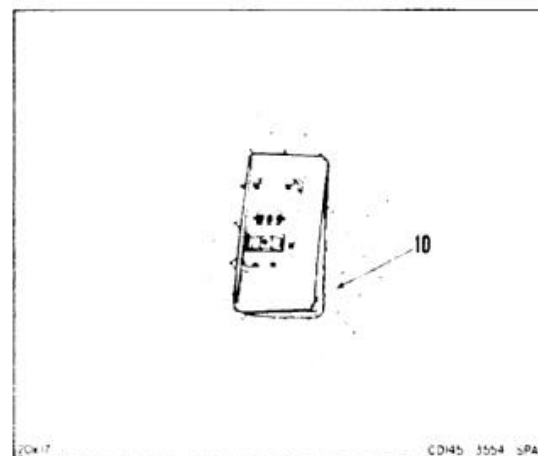

END OF TASK

17-11 REMOVE INERTIA SWITCH

17-11

INITIAL SETUP**Applicable Configurations:**

All

Tools:

Electrical Repairer's Tool Kit, NSN 5180-00-323-4915

Materials:

None

Personnel Required:

Aircraft Electrician

Equipment Condition:

Battery Disconnected (Task 1-39)
 Electrical Power Off

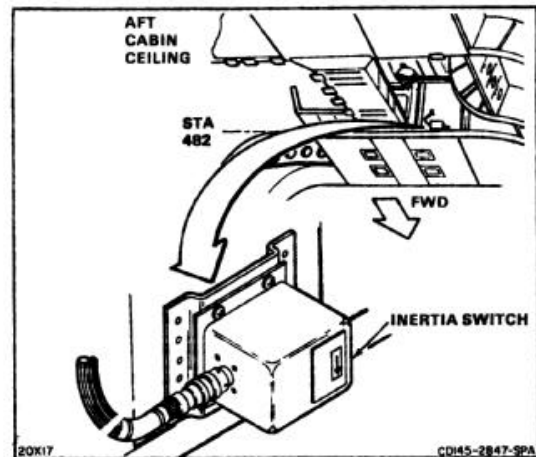

1. Disconnect connector (1).
2. Remove four screws (2) and washers (3).
3. Remove inertia switch (4).

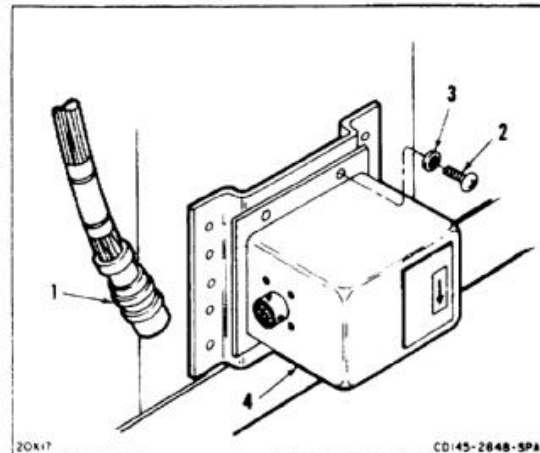
**FOLLOW-ON MAINTENANCE:**

None

END OF TASK

INITIAL SETUP

Applicable Configurations:

All

Tools:

Electrical Repairer Tool Kit, NSN 5180-00-323-4915

Materials:

None

Personnel Required:Aircraft Electrician
Inspector**References:**

TM 55-1520-240-23P

1. Position inertia switch (1) on structure (2) with arrow (3) pointing down.
2. Install four screws (4) and washers (5).
3. Connect connector (6).

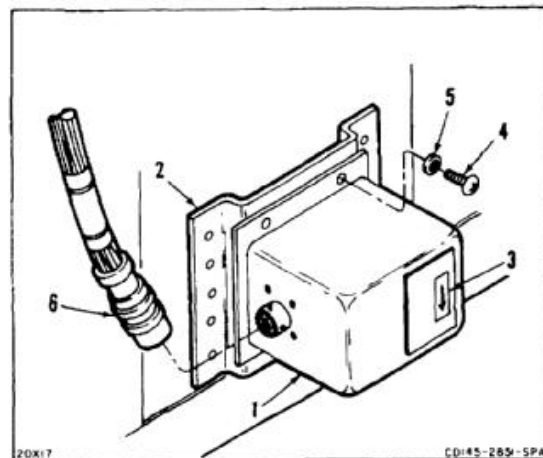
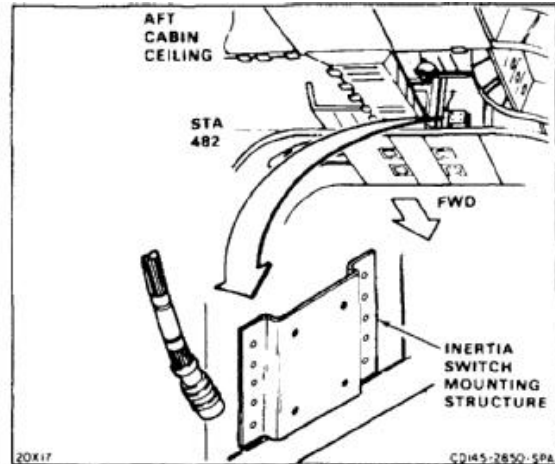
INSPECT**FOLLOW-ON MAINTENANCE:**

Perform operational check (TM 55-1520-240-T).

END OF TASK

APPENDIX A REFERENCES

AMS 5680	Steel Welding Wire, Corrosion and Heat Resistant
AMSTM-E1417	Liquid Penetrant Examination, Standard Practice For
AR 40-66	Medical Record Administration and Health Care Documentation
DA Form 2408-15	Historical Record for Aircraft
DA Form 2408-17	Aircraft Inventory Record
DA PAM 738-751	Functional Users Manual for the Army Maintenance Management System Aviation (TAMMS-A)
FM 1-202	Environmental Flight
FM 3-5	NBC Decontamination
FM 10-67-1	Concepts and Equipment of Petroleum Operations
FM 4-25.11	First Aid for Soldiers
FM 1-409	Fundamentals of Aircraft Pneudraulics
FM 10-450-3,-450-4,-450-5	Multiservice Helicopter Sling Load
MIL-A-8625	Anodic Coatings for Aluminum and Aluminum Alloys
MIL-C-53072B	Chemical Agent Resistent Coating (CARC) system application procedures and quality control inspection
MIL-C-5541	Chemical Conversion Coatings on Aluminum and Aluminum Alloys
SAE-AMS-M-3171	Magnesium Alloy, Processes for Pretreatment and Prevention of Corrosion on
ASTM-D-1732	Painting for Magnesium Alloy Surface, Preperation of
MIL-STD-130K	Identification marking of US Military Property
MIL-STD-865	Selective (Brush Plating) Electrodeposition
NAVAIR 19-1-137	Operation and Intermediate Maintenance Instructions with Illustrated Parts Breakdown for Towbar, Aircraft, Model ALBAR and Model NT-4/NT-4A.
SAE-AMS-STD-2219	Fusion Welding for Aerspce Applications
QQ-P-416	Plating, Cadmium (Electrodeposited)
DA PAM 40-501	Program Hearing Conservation
TB 1-1520-240-20-75	Stratopower pumps, CH-47D
TB 43-0106	Army Oil Analysis Program (AOAP)
TB 55-8100-200-24	Maintenance of Specialized Reuseable Containers for Aircraft Equipment
TM 1-6625-724-13P	Test Set, AVA Maintenance manual with RPSTL
TM 1-1500-344-23	Aircraft weapons systems cleaning and corrosion control
TM 1-1520-250-23-1	Aviation Unit and Intermediate Maintenance Manual for General Tiedown and Mooring, All Series Army Models AH-64, UH-60, CH-47, UH-1, AH-1, and CH-58 Helicopters.
TM 1-1520-252-23P	Repair parts and special tools list
TM 1-1520-254-23	Nondestructive Inspection procedures for OH-58 Acft
TM 11-1520-240-23	Aviation Unit and Intermediate Maintenance Manual for Electronic Equipment Configurations of Army Model CH-47D Helicopter
TM 11-5855-300-23&P	Aviation Intermediate Maintenance Manual (Including Repair Parts and Special Tools List): Head Up Display AN/AVS-7, NSN 5855-01-350-0349
TM 11-6140-203-23	Aviation Unit and Intermediate Maintenance Manual for Aircraft Nickel-Cadmium Batteries
TM 11-6625-273-12	Operation and Organizational Maintenance Insulation Breakdown

TM 11-6625-273-35	Field and Depot Maintenance Manual: Test Sets, Insulation Breakdown AN/GSM-6 and AN/GSM-6AS
TM 11-6625-277-14	Operator's, Organizational, Direct Support, and General Support Maintenance Manual: Meter Test Sets TS-682/GSM-1 and TS62AIGSM-1
TM 11-6625-396-12	Operator's and Organizational Maintenance Manual: Stroboscopes
TM 11-6625-2843-14	Operator's, Organizational, Direct Support, and General Support Maintenance Manual for Test Set, Synchro TTU-23/E
TM 11-6625-396-12	Operator's and Organizational Maintenance Manual: Stroboscopes TS-8058/U, TS-805C/U, and TS-805D/U
TM 43-0104	General Use of Rosan Fasteners
TM 43-0139	Painting Instructions for Field Use
TM 1-1500-204-23	General Aircraft Maintenance Manual
TM 1-1500-344-23	Aircraft Weapons Systems Cleaning and Corrosion Control
TM 1-1520-240-10	Operator's Manual for Army CH-47D Helicopter
TM 55-1520-240-23	This is a series of 10 volumes, Aviation Unit and Aviation Intermediate Maintenance Manual for CH-47D Helicopters
TM 55-1500-322-24	Maintenance of Aeronautical Antifriction Bearings for Organizational, Intermediate, and Depot Maintenance Level
TM 55-1500-323-24	Installation practices for Aircraft Electric and Electronic Wiring
TM 1-1500-328-23	Aeronautical Equipment Maintenance Management Policies and Procedures
TM 1-1500-335-23	Nondestructive Inspection Methods
TM 1-1500-343-23	Cleaning and Corrosion Prevention and Control, Avionics
TM 55-1500-344-23	Aircraft Weapons Systems Cleaning and Corrosion Control
TM 55-1500-345-23	Painting and Marking of Army Aircraft
TM 1-1520-240-MTF	Maintenance Test Flight Manual for Army Model CH-47D Helicopter
TM 55-1520-240-PM	CH-47D Helicopter Phased Maintenance Checklist
TM 55-1520-240-PMD	CH-47D Helicopter Preventive Maintenance Daily Inspection Checklist
TM 55-1520-240-T	Aviation Unit and Aviation Intermediate Troubleshooting Manual: CH-47D Helicopter
TM 55-1520-240-23P	Aviation Unit and Intermediate Maintenance Repair Parts and Special Tools List (Including Depot Maintenance Repair Parts and Special Tools) Helicopter, Cargo Transport CH-47D
TM 55-1520-241-S	Preparation for Shipment of CH-47 Helicopter
TM 55-1730-229-12	Power Unit, Aviation (AGPU)
TM 55-1730-229-34	Power Unit, Aviation, Multi-Output
TM 55-2835-205-23	Aviation Unit and Intermediate Maintenance for Gas Turbine Engine (Auxiliary Power Unit-APU) Model T-62T-2B, Part No. 16050-100
TM 55-2840-254-23	Aviation Unit and Aviation Intermediate Maintenance Manual for Engine, Gas Turbine, Model T55-L-712
TM 55-2840-254-23P	Aviation Unit and Intermediate Repair Parts and Special Tools List (Including Depot Maintenance Repair Parts and Special Tools) for Engine, Gas Turbine, T55-L-712
TM 55-1500-342-23	Army Aviation Maintenance Engineering Manual for Weight and Balance
TM 55-4920-231-14	Tester, Pitot and Static Systems
TM 55-4920-243-15	Operator, Organizational. Direct Support, General Support, and Depot Maintenance Manual: Vibration Monitoring Kit, Part No. 171170-0104
TM 55-4920-335-14	Operator's, Organizational, Direct Support, and General Support Maintenance Manual (Including Illustrated Parts Breakdown): Hydraulic Test Stand Type D5-B, Part No. 674016

TM 55-1520-240-23-11

TM 55-4920-373-14&P	Operating Instructions: Organizational, Direct, and General Support Maintenance Manual (Including Repair Parts and Special Tools List) for Gasoline Engine Driven Hydraulic Systems Test Stand, Type D5-B
TM 55-4920-378-14&P	Operator's, Organizational, Direct Support, and General Support Maintenance Manual (Including Repair Parts and Special Tools List), Tester, Pitot and Static System (Mfr. Part No. TPS-2550-1) (Mfr. Part No. TPS 2550-2) (NSN 4920-00-718-6480)
TM 55-4920-401-13&P	Operator's, Aviation Unit, and Aviation Intermediate Maintenance Manual (Including Repair Parts and Special Tools List): Tester, Exhaust Gas Temperature, BH112BJ-53
TM 55-4920-402-13&P	Operator's, Aviation Unit, and Aviation Intermediate Maintenance Manual (including Repair Parts and Special Tools List) for Vibrex Balancing Kit, Part No. B4591
TM 55-4920-428-13	Operator's, Aviation Intermediate Maintenance and Illustrated Parts Breakdown Test Set, Bench, Integrated Lower Control Actuator (ILCA) 145GS278-1 NSN 4920-01-121-0604
TM 1 2840-265-23	Aviation Unit and Aviation Intermediate Maintenance Manual Engine. Gas Turbine Model T55-GA-714A
TM 1-2840-265-23P	Aviation Unit and Aviation Intermediate Maintenance Repair Parts and Special Tool List (Including Depot Maintenance Repair Parts and Special Tools) Engine, Gas Turbine Model T55-GA-714A
TM 55-4920-429-13	Operator's, Aviation Unit, and Aviation Intermediate Maintenance and Illustrated Parts Breakdown: Test Set, Line, Advanced Flight Control System 145G0009-1
TM 55-4920-430-13	Operator's, Aviation Intermediate Maintenance, and Illustrated Parts Breakdown: Test Set, Bench, Advanced Flight Control System (AFCS) 145G0008-1
TM 740-90-1	Administrative Storage of Equipment
TM 750-244-1-5	Procedures for the Destruction of Aircraft and Associated Equipment to Prevent Enemy Use

APPENDIX B
MAINTENANCE ALLOCATION CHART

SECTION I

B-1. MAINTENANCE ALLOCATION CHART.

- a. This Maintenance Allocation Chart (MAC) assigns maintenance functions in accordance with the Three Levels of Maintenance concept for Army aviation. These maintenance levels (categories) — Aviation Unit Maintenance (AVUM), Aviation Intermediate Maintenance (AVIM), and Depot Maintenance — are depicted on the MAC as:

AVUM, which corresponds to an O Code in the Repair Parts and Special Tools List (RPSTL)

AVIM, which corresponds to an F Code in the Repair Parts and Special Tools List (RPSTL)

DEPOT, which corresponds to a D Code in the Repair Parts and Special Tools List (RPSTL)

- b. The maintenance to be performed below depot and in the field is described as follows:

- (1) Aviation Unit Maintenance (AVUM). Activities will be staffed and equipped to perform high frequency on-aircraft maintenance tasks required to retain or return aircraft systems to a serviceable condition. The maintenance capability of AVUM will be governed by the Maintenance Allocation Chart (MAC) and limited by the amount and complexity of ground support equipment (GSE), facilities required, authorized manning strength, and critical skills available. The range and quantity of authorized spare modules/components will be consistent with the mobility requirements dictated by the air mobility concept. (Assignments of maintenance tasks to divisional company size aviation units will consider the overall maintenance capability of the division, the requirement to conserve personnel and equipment resources, and air mobility requirements.)
 - (a) Company Size Aviation Units. Perform those tasks which consist primarily of preventive maintenance and maintenance repair and replacement functions associated with sustaining a high level of aircraft operational readiness. Perform maintenance inspections and servicing to include preflight, daily, intermediate, periodic (or phased), and special inspections as authorized by the MAC or higher headquarters. Identify the cause of equipment/system malfunctions using applicable technical manual troubleshooting instructions, built-in-test equipment (BITE), installed aircraft instruments, or test, measurement, and diagnostic equipment (TMDE). Replace worn or damaged modules/components that do not require complex adjustments or system alignment and which can be removed/installed with available skills, tools, and ground support equipment. Perform operational and continuity checks and make minor repairs to the electrical system. Inspect, service and make operational, check capacity and pressure of hydraulic systems. Perform servicing, functional adjustments, and minor repair/replacement to the flight control, propulsion, power train, and fuel systems. Accomplish airframe repair that does not require extensive disassembly, jiggling, or alignment. The manufacture of airframe parts will be limited to those items which can be fabricated with tools and equipment found in current air mobile tool and ship sets. Evacuate unserviceable modules/components and end items beyond the repair capability of AVUM to the supporting AVIM.
 - (b) Less than Company Size Aviation Units. Aviation elements organic to brigade, group, battalion headquarters, and detachment size units are normally small and have less than ten aircraft assigned. Maintenance tasks performed by these units will be those which can be accomplished by the aircraft crew chief or assigned aircraft repairman and will normally be limited to preventive maintenance, inspections, servicing, spot painting, stop drilling, application of nonstress patches, minor adjustments, module/component fault diagnosis, and replacement of selected modules/components. Repair functions will normally be accomplished by the supporting AVIM unit.

- (2) Aviation Intermediate Maintenance (AVIM) provides mobile, responsive One-Stop maintenance support. (Maintenance functions which are not conducive to sustaining air mobility will be assigned to depot maintenance). AVIM may perform all maintenance functions authorized to be done at AVUM. Repair of equipment for return to user will emphasize support or operational readiness requirements. Authorized maintenance includes replacement and repair of modules/components and end items which can be accomplished efficiently with available skills, tools, and equipment. AVIM establishes the Direct Exchange (DX) program for AVUM units by repairing selected items for return to stock when such repairs cannot be accomplished at the AVUM level. The AVIM level inspects, troubleshoots, performs diagnostic tests, repairs, adjusts, calibrates, and aligns aircraft system modules/components. AVIM units will have capability to determine the serviceability of specified modules/components removed prior to the expiration of the Time Between Overhaul (TBO) or finite life. Module/component disassembly and repair will support the DX program and will normally be limited to tasks requiring cleaning and the replacement of seals, fittings, and items of common hardware. Airframe repair and fabrication of parts will be limited to those maintenance tasks which can be performed with available tools and test equipment. Unserviceable repairable modules/components and end items which are beyond the capability of AVIM to repair will be evacuated to Depot Maintenance. AVIM will perform aircraft weight and balance inspections and other special inspections which exceed AVUM capability. AVIM provides quick response maintenance support, including aircraft recovery and air evacuation, on-the-job training, and technical assistance through the use of mobile maintenance contact teams. Maintains authorized operational readiness float aircraft. Provides collection and classification services for serviceable/unserviceable material. Operates a cannibalization activity in accordance with AR 750-1. (The aircraft maintenance company within the maintenance battalion of a division will perform AVIM functions consistent with air mobility requirements and conservation of personnel and equipment resources. Additional intermediate maintenance support will be provided by the supporting nondivisional AVIM unit.)

SECTION II

B-2. USE OF THE MAINTENANCE ALLOCATION CHART.

NOTE

Nomenclatures used throughout the MAC are approved item names. Those terms/nomenclatures expressed in parentheses are generic in nature and are not to be considered as official terminology.

- a. The Maintenance Allocation Chart assigns maintenance functions to the lowest category of maintenance based on past experience and the following considerations:
 - (1) Skills available.
 - (2) Work time required.
 - (3) Tools and test equipment required and/or available.
- b. Only the lowest category of maintenance authorized to perform a maintenance function is indicated. If the lowest maintenance category cannot perform all tasks of any single maintenance function (e.g., test, repair), then the higher maintenance level(s) that can accomplish additional tasks will also be indicated.
- c. A maintenance function assigned to a maintenance category will automatically be authorized to be performed at any higher maintenance category.
- d. A maintenance function that cannot be performed at the assigned category of maintenance for any reason may be evacuated to the next higher maintenance category. Higher maintenance categories will perform the maintenance functions of lower maintenance categories when required or directed by the commander that has the authority to direct such tasking.
- e. The assignment of a maintenance function will not be construed as authorization to carry the related repair parts or spares in stock. Information to requisition or otherwise secure the necessary repair parts will be as specified in the associated Repair Parts and Special Tools List (RPSTL).
- f. Normally there will be no deviation from the assigned level of maintenance. In cases of operational necessity, maintenance functions assigned to a maintenance level may, on a one-time basis and at the request of the lower maintenance level, be specifically authorized by the maintenance officer of the level of maintenance to which the function is assigned. The special tools, equipment, etc., required by the lower level of maintenance to perform this function will be furnished by the maintenance level to which the function is assigned. This transfer of a maintenance function to a lower maintenance level does not relieve the higher maintenance level of the responsibility for the function. The higher level of maintenance has the authority to determine:
 - (1) If the lower level is capable of performing the work.
 - (2) If the lower level will require assistance or technical supervision and on-site inspection.
 - (3) If the authorization will be granted.
- g. Changes to the Maintenance Allocation Chart will be based on continuing evaluation and analysis by responsible technical personnel and on reports received from field activities.

B-3. MAINTENANCE FUNCTIONS.

Maintenance functions will be limited to and defined as follows:

- a. *Inspect.* To determine the serviceability of an item by comparing its physical, mechanical, and/or electrical characteristics with established standards through examination.
- b. *Test.* To verify serviceability by measuring the mechanical or electrical characteristics of an item and comparing those characteristics with prescribed standards.
- c. *Service.* Operations required periodically to keep an item in proper operating condition, i.e., to clean (includes decontaminate, when required), to preserve, to drain, to paint, or to replenish fuel, lubricants, chemical fluids, or gases.
- d. *Adjust.* To maintain, within prescribed limits, by bringing into proper or exact position, or by setting the operating characteristics to specified parameters.
- e. *Align.* To adjust specified variable elements of an item to bring about optimum or desired performance.

- f. *Calibrate.* To determine and cause corrections to be made or to be adjusted on instruments or test, measuring, and diagnostic equipment used in precision measurement. Consists of comparisons of two instruments, one of which is a certified standard of known accuracy, to detect and adjust any discrepancy in the accuracy of the instrument being compared.
- g. *Install.* The act of emplacing, seating, or fixing into position an item, part, or module (component or assembly) in a manner to allow the proper functioning of an equipment or system.
- h. *Replace.* The act of substituting a serviceable like type part, subassembly, or module (component or assembly) for an unserviceable counterpart.
- i. *Repair.* the application of maintenance services or other maintenance actions to restore serviceability to an item by correcting specific damage, fault, malfunction, or failure in a part, subassembly, module (component or assembly), end item, or system.
- j. *Overhaul.* That maintenance effort (service/action) necessary to restore an item to a completely serviceable/operational condition as prescribed by maintenance standards in appropriate technical publications (i.e., DMWR). Overhaul is normally the highest degree of maintenance performed by the Army. Overhaul does not normally return an item to like new condition.
- k. *Rebuild.* Consists of those services/actions necessary for the restoration of unserviceable equipment to a like new condition in accordance with original manufacturing standards. Rebuild is the highest degree of materiel maintenance applied to Army equipment. The rebuild operation includes the act of returning to zero those age measurements (hours/miles. etc.) considered in classifying Army equipments/components.

B-4. STANDARD GROUPS (COLUMNS 1 AND 2).

The standard groupings shown in the sample below are used, as applicable, throughout this MAC. Maintenance manuals and RPSTL will reflect these standard groupings as individual chapters, with sections in each chapter relative to the individual complete systems, subsystems, modules, components, assemblies, or specific parts noted.

GROUP NUMBER	DESCRIPTION
01	Aircraft General
02	Airframe System
03	Alighting Gear
04	Powerplant Installation
05	Blades/Rotor Systems
06	Train Systems
07	Hydraulic Systems
08	Instrument Systems
09	Electrical System
10	Fuel System
11	Flight Controls System
12	Utility System
13	Environmental Control System
14	Hoists and Winches
15	Auxiliary Powerplant System
16	Mission Equipment
17	Emergency Equipment

- 1. Service - respect test, service adjust, align calibrate, or replace
- 2. Actions - welding, grinding, riveting, straightening, facing, remachining, or resurfacing

B-5. MAINTENANCE FUNCTION (COLUMN 3).

Column 3 lists the functions to be performed on the items listed in column 2.

B-6. MAINTENANCE CATEGORIES AND WORK TIMES (COLUMN 4).

The maintenance categories (levels) AVUM, AVIM, and DEPOT are listed on the Maintenance Allocation Chart with individual columns that include the work times for maintenance functions at each maintenance level. Work time presentations such as "0.1" indicate the average time it requires a maintenance level to perform a specified maintenance function. If a work time has not been established, the columnar presentation shall indicate "-.-" Maintenance levels higher than the level of maintenance indicated are authorized to perform the indicated function.

B-7. TOOLS AND TEST EQUIPMENT (COLUMN 5 AND SECTION III).

Common tool sets (not individual tools), special tools, test, and support equipment required to perform maintenance functions are listed alphabetically in Section III with a reference number to permit cross-referencing to column 5 in the MAC. In addition, the maintenance category authorized to use the device is listed along with the item National Stock Number (NSN) and, if applicable, the tool number to aid in identifying the tool/device.

B-8. REMARKS (COLUMN 6 AND SECTION IV).

Remarks (identified by an alphabetic code in column 6) and other notes (identified by a number in parentheses in the applicable column) are listed in Section IV to provide a ready reference to the definition of the remark/note.

MAINTENANCE ALLOCATION CHART							
Section II							
NOMENCLATURE OF END ITEMS							
(1) Group Number	(2) Component/Assembly	(3) Maintenance Function	(4) Maintenance Category			(5) Tools and Equipment	(6) Remarks
			AVUM	AVIM	DEPOT		
00	AIRCRAFT SYSTEM						
01	AIRCRAFT GENERAL						
0101	Aircraft Hoisting			--		T4, T71, 278	
0102	Spot Painting		--				
0103	Cleaning, Fuselage Exterior		--			203, 204, 205, 278	
0104	Servicing, General		--			250, 278	
0105	Parking		--				
0106	Moor		--			T40, 220	
0107	Tow		--			T75, T82, 278	
0108	Jacking		--			278, 279	
0109	Preservation		--			T21, T58, T59, T60, T61, T66, T67, T68, T76, T80, T81, T103, T107, T131, T132, 228, 278	
0110	Weight and Balance			--			
0111	Complete Painting				--		
0112	Subassembly Painting			--		226	
0113	Rosan Fittings and Studs	Replace	--			222, 282,	
				--		222, 237, 242	
02	AIRFRAME						
0201	Cockpit Section	Inspect	--			274	
		Replace		--			
		Repair	--			275, 278	1, 25
				--		275, 278	15, 25, 26
					--		

MAINTENANCE ALLOCATION CHART							
Section II							
NOMENCLATURE OF END ITEMS							
(1) Group Number	(2) Component/Assembly	(3) Maintenance Function	(4) Maintenance Category			(5) Tools and Equipment	(6) Remarks
			AVUM	AVIM	DEPOT		
020101	Nose Enclosure	Inspect	--			274	
		Replace			--		
		Repair	--			275, 278	1, 25
020102	Bulkhead Sta. 95	Inspect	--			274	
		Replace			--		
		Repair	--	--		275, 278	15, 25, 26
020103	Frame Sta. 120	Inspect	--			274	
		Replace			--		
		Repair	--			275, 278	1, 25
020104	Frame Sta. 140	Inspect	--			274	
		Replace			--		
		Repair	--	--		275, 278	15, 25, 26
020105	Frame Sta. 160	Inspect	--			274	
		Replace			--		
		Repair	--	--		275, 278	1, 25
020106	Side Panel	Inspect	--			274	
		Replace			--		
		Repair	--			275, 278	1, 25
020107	Crown Panel	Inspect	--			274	
		Replace			--		
		Repair	--	--		275, 278	15, 25, 26

MAINTENANCE ALLOCATION CHART							
Section II							
NOMENCLATURE OF END ITEMS							
(1) Group Number	(2) Component/Assembly	(3) Maintenance Function	(4) Maintenance Category			(5) Tools and Equipment	(6) Remarks
			AVUM	AVIM	DEPOT		
020108	Former Sta. 51.75	Inspect	--			274	
		Replace			--		
		Repair	--			275, 278	1, 25
020109	Former Sta. 70.62	Inspect	--			274	
		Replace			--		
		Repair	--	--		275, 278	1, 25
020110	Former Sta. 95	Inspect	--			274	
		Replace			--		
		Repair	--	--		275, 278	15, 25, 26
020111	Former Sta. 120	Inspect	--			274	
		Replace			--		
		Repair	--	--		275, 278	1, 25
020112	Former Sta. 160	Inspect	--			274	
		Replace			--		
		Repair	--	--		275, 278	15, 25, 26
020113	Bottom Panel	Inspect	--			274	
		Replace			--		
		Repair	--	--		275, 278	1, 25
020114	Flooring	Inspect	--			274	
		Replace	--			278	
		Repair	--			275	

MAINTENANCE ALLOCATION CHART							
Section II							
NOMENCLATURE OF END ITEMS							
(1) Group Number	(2) Component/Assembly	(3) Maintenance Function	(4) Maintenance Category			(5) Tools and Equipment	(6) Remarks
			AVUM	AVIM	DEPOT		
020115	Access Doors, Covers, Panels, Jettison Doors and Work Platforms	Inspect	--			274	
		Replace	--			275, 278	1, 25
		Repair	--			275, 278	1, 25
020116	Windshield and Windows	Inspect	--			275, 278	
		Replace	--			274	
		Repair	--			T167, T168, 232, 278	
020117	Formers, Stringer Longerons, Brackets, Angles, Webs	Inspect	--			231, 242, 275, 292, 293	
		Replace	--	--		274	
		Repair	--		--	275, 278	15, 25, 26
020118	Skin, Cockpit	Inspect		--		275, 278	15, 25, 26
		Replace		--		275, 278	15, 25, 26
					--		
020119	Pilot & Copilot Seat & Cushions	Inspect	--				
		Test	--				
		Adjust	--			278	
		Replace	--			278	
		Repair	--				3
020120	Inertia Reel, Harness & Belt	Inspect	--			278	
		Adjust	--			278	
		Replace	--				
020121	Acoustical Insulation	Inspect	--				
		Replace	--			278	
		Repair	--				
020122	Map/Data Case	Inspect	--			278	
		Replace	--				

MAINTENANCE ALLOCATION CHART							
Section II							
NOMENCLATURE OF END ITEMS							
(1) Group Number	(2) Component/Assembly	(3) Maintenance Function	(4) Maintenance Category			(5) Tools and Equipment	(6) Remarks
			AVUM	AVIM	DEPOT		
020123	Self-Tuning Absorber	Inspect	--				
		Test	--			T112	
		Adjust	--			T112, T84	
		Replace	--			259, 278	
020124	Absorber System Test Box (ACFT)	Inspect	--				
		Replace	--			278	
		Repair			--		
0202	Fwd Transmission Fixed Fairing	Inspect	--				
		Replace			--		
		Repair	--			274	
020201	Transmission Support Beams	Inspect	--				
		Replace		--		275, 278	1, 25
		Repair	--			274	
020202	Transmission Mount Bushing	Inspect	--				
		Replace	--			275, 278	
		Repair		--			
020203	Fwd Transmission Fwd & Aft Fairing	Inspect	--				
		Remove	--			274	
		Repair	--			275, 278	
020204	Work Platforms & Panels	Inspect	--				
		Remove	--			274	
		Repair	--			275, 278	
020205	Bulkheads, Beams & Fittings	Inspect	--				
		Remove			--	274	
		Repair	--			275, 278	1, 25
				--		275, 278	15, 25, 26

MAINTENANCE ALLOCATION CHART							
Section II							
NOMENCLATURE OF END ITEMS							
(1) Group Number	(2) Component/Assembly	(3) Maintenance Function	(4) Maintenance Category			(5) Tools and Equipment	(6) Remarks
			AVUM	AVIM	DEPOT		
0203	Cabin Section	Inspect	--				
		Replace			--		
		Repair	--			275, 278	1, 25
020301	Side Panels	Inspect	--				
		Replace			--		
		Repair	--			275, 278	1, 25
020302	Crown Panel	Inspect	--				
		Replace			--		
		Repair	--			275, 278	15, 25, 26
020303	Crown Formers Sta. 180, 220, 260, 300, 380, 420	Inspect	--				
		Replace			--		
		Repair	--			275, 278	1, 25
020304	Skin, Fuselage	Inspect	--				
		Replace			--		
		Repair	--			275, 278	15, 25, 26
020305	Formers Sta. 200, 240, 280, 320, 360, 400	Inspect	--			274	
		Replace			--		
		Repair	--			275, 278	1, 25
					--		
						275, 278	15, 25, 26

MAINTENANCE ALLOCATION CHART							
Section II							
NOMENCLATURE OF END ITEMS							
(1) Group Number	(2) Component/Assembly	(3) Maintenance Function	(4) Maintenance Category			(5) Tools and Equipment	(6) Remarks
			AVUM	AVIM	DEPOT		
020306	Walkway	Inspect	--				
		Replace		--		275, 278	15, 25, 26
		Repair	--		--	275, 278	1, 25
				--		275, 278	15, 25, 26
020307	Formers, Stringers, Longerons, Ribs, Brackets, Angles, Webs	Inspect	--			274	
		Replace		--		275, 278	1, 25
		Repair	--		--	275, 278	1, 25
			--	275, 278	15, 25, 26		
020308	Fairings, Panels and Honeycomb Panels	Inspect	--			274	
		Replace	--				
		Repair	--		--	275, 278	1, 25
020309	Fuel Pods	Inspect	--			274	
		Replace	--			274	
		Repair	--		--	275, 278	1, 25
				--		206, 247	1, 25
020310	Fuel Pods, Composite	Repair	--		--	206, 247	25, 26
					--	275, 303	
020311	Backing Boards and Isolation	Inspect	--			274	
		Replace	--			275	
020312	Cabin Access, Escape, Rescue Door and Actuating Mech	Inspect	--			274	
		Adjust	--			278	
		Replace	--			275, 278	1, 25
		Repair	--			262, 263, 274	

MAINTENANCE ALLOCATION CHART							
Section II							
NOMENCLATURE OF END ITEMS							
(1) Group Number	(2) Component/Assembly	(3) Maintenance Function	(4) Maintenance Category			(5) Tools and Equipment	(6) Remarks
			AVUM	AVIM	DEPOT		
020313	Cabin Flooring	Inspect	--			274	
		Replace	--			275, 278	1, 25
		Repair	--			275, 278	1, 25
020314	Cargo Tiedown Fittings, 5000-Pound	Inspect	--			274	
		Replace	--			275, 278	
020315	Cargo Tiedown Fittings, 10,000-Pound	Inspect	--			278	
		Replace	--			278	
020316	Water Drain System	Inspect	--			274	
		Replace	--			278	
020317	Windows	Inspect	--			274	
		Replace	--			262, 263	
020318	Seals/Retainers	Inspect	--				
		Replace	--			278,262, 263	
020319	Troop, Troop Commander Seats & Webbing	Inspect	--			274	
		Replace	--			278	
		Repair	--			278	3
020320	Acoustical Insulation and Curtain, Axe Holder, Stowage Bag & Container	Inspect	--			274	
		Replace	--			278	
		Repair	--			278	3
020321	Rescue Door Actuator	Inspect	--				
		Replace	--			278	
0204	Aft Fuselage	Inspect	--			274	
		Replace			--		
		Repair	--			275, 278	1, 25
020401	Support Assy, Combining Transmission (Beam & Support Fittings)	Inspect	--	--		275, 278	15, 25, 26
		Replace			--	274	
		Repair			--		3

MAINTENANCE ALLOCATION CHART							
Section II							
NOMENCLATURE OF END ITEMS							
(1) Group Number	(2) Component/Assembly	(3) Maintenance Function	(4) Maintenance Category			(5) Tools and Equipment	(6) Remarks
			AVUM	AVIM	DEPOT		
020402	Beam & Support Bushings	Inspect	--			274	
		Replace		--		275, 278	
020403	Former Sta. 440, 482, 502, 437, 520, 534, 555, 575, 594	Inspect	--			274	
		Replace			--		
		Repair	--			275, 278	1, 25
020404	Aft Fuselage Crown Panel			--		275, 278	15, 25, 26
		Inspect	--			274	
		Replace			--		
020405	Aft Fuselage Side Panels	Repair	--			275, 278	1, 25
				--		275, 278	15, 25, 26
		Inspect	--			274	
020406	Aft Fuselage Bottom Panel	Replace			--		
		Repair	--			275, 278	1, 25
				--		275, 278	15, 25, 26
020407	Formers, Ribs, Longerons Stringers/Beams	Inspect	--			274	
		Replace			--		
		Repair	--			275, 278	1, 25
020408	Access Doors, Panels, Work Platforms			--		275, 278	15, 25, 26
		Inspect	--			274	
		Replace	--			275, 278	1, 25
		Repair	--			275, 278	1, 25
				--		275, 278	

MAINTENANCE ALLOCATION CHART							
Section II							
NOMENCLATURE OF END ITEMS							
(1) Group Number	(2) Component/Assembly	(3) Maintenance Function	(4) Maintenance Category			(5) Tools and Equipment	(6) Remarks
			AVUM	AVIM	DEPOT		
020409	Cargo Loading Ramp & Ramp Extension	Inspect	--			274	
		Replace	--			275, 278	
		Repair	--			275, 278	1, 25
				--		--	275, 278
020410	Ramp Flooring	Inspect	--			274	
		Replace	--			275, 278	1, 25
		Repair	--			275, 278	1, 25
020411	Cargo Loading Ramp, Composite	Inspect	--				
		Replace			--		
		Repair		--		275, 278	25, 26
020412	Ramp Hinge Fittings	Inspect	--				
		Replace		--		275, 278	
020413	Ramp Door Actuator Mechanism	Inspect	--				
		Service	--				
		Test	--			231, 278	
		Adjust	--			231, 278	
		Replace	--				
		Repair	--			278	
020414	Cargo Door Ramp Seals	Inspect	--				
		Replace	--			275	
020415	Ramp Door Assembly Track and Actuator Mechanism	Inspect	--			274	
		Adjust	--			278	
		Replace	--			278	
		Repair	--			275, 278	1, 25
020416	M-24 Sub System			--		275, 278	
		Inspect	--			274	
		Replace	--			278	

MAINTENANCE ALLOCATION CHART							
Section II							
NOMENCLATURE OF END ITEMS							
(1) Group Number	(2) Component/Assembly	(3) Maintenance Function	(4) Maintenance Category			(5) Tools and Equipment	(6) Remarks
			AVUM	AVIM	DEPOT		
0205	Aft Pylon	Inspect	--			274	
		Replace	--			T17, T16, T32, T54, T55, T55.1 278, 282	
		Repair	--			275	1, 25
020501	Pylon Drain Lines	Inspect	--			275	
		Replace	--			278	
020502	Aft Pylon Fairings, Work Platforms, Panels	Inspect	--			274	
		Replace	--			278	
		Repair	--			275, 278	1, 2
020503	Pylon Fairing Latches	Inspect	--			275, 278	
		Repair	--			278	
020504	Aft Transmission Support Structure	Inspect	--			274	
		Replace	--		--		
		Repair	--			275	1, 25
020505	Aft Rotary Wing Drive Shaft Support Structure	Inspect	--			275	15, 25, 26
		Replace	--		--	274	
		Repair	--			275	1, 25
020506	Formers, Stringers, Longerons, Beams	Inspect	--			275	15, 25, 26
		Replace	--			274	
		Repair	--			275	15, 25, 26
020507	Skin Pylon	Inspect	--			275	
		Replace	--			274	
			--			275	
		Repair	--			274, 275	
			--			274, 275	

MAINTENANCE ALLOCATION CHART							
Section II							
NOMENCLATURE OF END ITEMS							
(1) Group Number	(2) Component/Assembly	(3) Maintenance Function	(4) Maintenance Category			(5) Tools and Equipment	(6) Remarks
			AVUM	AVIM	DEPOT		
020508	Fwd Actuator Support	Inspect	--			274	
		Replace			--		
		Repair	--			278	1, 25
020509	Aft Actuator Support	Inspect	--			278	15, 25, 26
		Replace			--	274	
		Repair	--			278	1, 25
020510	Support Aft Swiveling Actuator	Inspect	--			278	15, 25, 26
		Replace			--	274	
		Repair	--			278	1, 25
020511	Canted Deck	Inspect	--			278	15, 25, 26
		Replace			--	274	
		Repair	--			278	1, 25
0206	Drip Pans (Fiberglass)	Inspect	--			278	
		Replace	--			274	
		Repair	--			274, 275	1, 2
020601	Drip Pans (Aluminum)	Inspect	--			274, 275	
		Replace	--	--		274	
		Repair	--			278	
0207	Grounding Receptacle (Ferry Fuel)	Inspect	--			274, 275	
		Replace	--			278	
0208	General						
020801	Hinges	Inspect	--			274	
		Repair		--		275	
020802	Extruded Parts	Inspect	--			274	
		Repair		--		275	
020803	Honeycomb	Inspect	--			274	
		Repair		--		275	

MAINTENANCE ALLOCATION CHART							
Section II							
NOMENCLATURE OF END ITEMS							
(1) Group Number	(2) Component/Assembly	(3) Maintenance Function	(4) Maintenance Category			(5) Tools and Equipment	(6) Remarks
			AVUM	AVIM	DEPOT		
020804	Skins and Webbing	Inspect	--			274	
		Repair		--		275	
020805	Canvas and Webbing	Inspect	--			274	
		Repair		--		275	
020806	Aluminum Tubing	Inspect	--			274	
		Repair		--		275	
020807	Rubber Seals	Inspect	--	--		274	
		Repair				275	
020809	Minor Damage	Inspect	--			274	
		Repair		--		275	
020810	Partial Damage	Inspect	--			274	
		Repair		--		275	
020811	Complete Damage	Inspect	--			274	
		Repair		--		275	
03	ALIGHTING GEAR						
0301	Shock Struts	Inspect	--			274	
		Service	--			278	
		Replace	--			243, 244, 278, 282	
		Repair		--		243, 244, 278, 282, T108, 221, 237, 242	
		Overhaul			--		
0302	Strut Air Valves	Inspect	--				
		Replace	--			278, 282	
0303	Strut Grease Fittings and Tow Lug	Inspect	--				
		Replace	--			278, 282	
0304	Torque Arm Assembly	Inspect	--				
		Replace	--			278, 282	

MAINTENANCE ALLOCATION CHART

Section II

NOMENCLATURE OF END ITEMS

(1) Group Number	(2) Component/Assembly	(3) Maintenance Function	(4) Maintenance Category			(5) Tools and Equipment	(6) Remarks
			AVUM	AVIM	DEPOT		
0305	Wheel and Tire Assemblies	Inspect	--			274	
		Service	--			278	
		Replace	--			230, 278, 282, 309	
		Repair	--			278, 282	
0306	Wheel Bearing	Inspect	--			274	
		Service	--			278	
		Replace	--			278, 282	
030601	Wheel Cups and Keys	Inspect	--				
		Replace	--			278	
0307	Forward and Aft Wheel Brake Disks and Wheel Brake Linings	Inspect	--			274	
		Replace	--			278	
0308	Wheel Brake Units	Inspect	--			274	
		Adjust	--			278	
		Replace	--			278, 282	
		Repair	--			278, 282	
0309	Drag Links	Inspect	--			274	
		Replace	--			245, 278, 282, 295	
		Repair		--		229, 237	
0310	Static Lock Mechanism	Inspect	--				
		Replace	--			278, 282	
0311	Power Steering Lever	Inspect	--				
		Replace	--			278	
0312	Forward and Aft Landing Gear Axle	Inspect	--				
		Replace	--			278, 282	
0313	Spindle and Swivel Housing Assembly	Inspect	--			278	
		Test	--				
		Replace	--			245, 278, 282	
		Repair	--		--	278, 282 T94, T97, 237, 242, 245, 278	

MAINTENANCE ALLOCATION CHART							
Section II							
NOMENCLATURE OF END ITEMS							
(1) Group Number	(2) Component/Assembly	(3) Maintenance Function	(4) Maintenance Category			(5) Tools and Equipment	(6) Remarks
			AVUM	AVIM	DEPOT		
0314	Swivel Lacks and Springs	Inspect	--				
		Replace	--			278	
0315	Static Ground Wire	Inspect	--				
		Replace	--			278	
0316	Proximity Switch	Inspect	--			278	
		Adjust	--			278	
		Replace	--			278, 282	
031601	Proximity Switch Bracket	Inspect	--				
		Repair	--				
		Replace		--		T89	
		Replace		--		278, 282	
04	POWERPLANT INSTALLATION						
0401	Demountable Powerplant	Inspect	--			278	
		Assembly	--			272, 278	7
		Test	--			272, 282	5
		Adjust	--			272	
		Replace	--			T16, T134, 258, 278, 282	
				Repair	--		
040101	Fuel Boost Pump	Depreserve	--			317	
		Inspect	--				
		Replace	--			272, 282	
040102	Fuel Flow Divider	Inspect	--				
		Replace	--			272	
040103	Engine Accessory Gearbox Chip Detector	Inspect	--				
		Replace	--			272	
040104	Starter Drive Shaft Seal	Inspect	--				
		Replace	--			272	

MAINTENANCE ALLOCATION CHART							
Section II							
NOMENCLATURE OF END ITEMS							
(1) Group Number	(2) Component/Assembly	(3) Maintenance Function	(4) Maintenance Category			(5) Tools and Equipment	(6) Remarks
			AVUM	AVIM	DEPOT		
040105	Starter Drive Housing	Inspect	--				
		Replace	--			272	
040106	Oil Pump	Inspect	--				
		Replace	--			272, 282	
040107	Oil Cooler	Inspect	--				
		Replace	--			272	
040108	Oil Filler Strainer Element	Inspect	--				
		Replace	--			272	
040109	Oil Filler	Inspect	--				
		Replace	--			272	
040110	Ignition Switch	Inspect	--				
		Replace	--			277, 282	
040111	Inline Fuel Filter	Inspect	--				
		Replace	--			272	
040112	Interstage Air Bleed Band	Inspect	--				
		Replace	--			272	
040113	Air Bleed Band Actuator	Inspect	--				
		Replace	--			272	
0402	Engine Access Cover	Inspect	--				
		Adjust	--			278	
		Replace	--			278	
		Repair	--			278	1, 2
040201	Cover Support Strut	Inspect	--	--		275	
		Replace	--			278	
0403	Engine Lower Access Door	Inspect	--				
		Replace	--			278	
		Repair	--			278	
				--		275	

MAINTENANCE ALLOCATION CHART								
Section II								
NOMENCLATURE OF END ITEMS								
(1) Group Number	(2) Component/Assembly	(3) Maintenance Function	(4) Maintenance Category			(5) Tools and Equipment	(6) Remarks	
			AVUM	AVIM	DEPOT			
0404	Engine Mount Drag Strut, Support Cap and Adapter	Inspect	--			274, 282		
		Replace	--			T134, 272, 278, 282, T109, 237		
		Repair	--			278, 282		
0405	Air Inlet and Bypass Screens	Adjust	--			275		
		Clean	--					
		Inspect	--					
		Replace	--			278		
		Repair	--					
				--				
				--				
040501	Screen Latch Assemblies, Cushions, Fasteners	Inspect	--					
		Replace	--			275		
0406	Air Inlet Fairing/Engine Cowling	Inspect	--					
		Adjust	--			275, 282		
		Repair	--					
0407	Tailpipe			--		278, 282		
		Replace	--					
		Inspect	--			278, 282		
		Replace	--			241		
0408	Fireshield Former Assembly	Repair	--			275, 291.1		
		Inspect	--					
		Adjust	--			278, 282		
		Replace	--			272		
0409	Control Linkages and Rods (N1 and N2)	Repair	--			275		
		Inspect	--				27	
		Adjust	--			272, 282		
		Replace	--			T122, 272, 282		
		Repair	--			272, 282		

MAINTENANCE ALLOCATION CHART							
Section II							
NOMENCLATURE OF END ITEMS							
(1) Group Number	(2) Component/Assembly	(3) Maintenance Function	(4) Maintenance Category			(5) Tools and Equipment	(6) Remarks
			AVUM	AVIM	DEPOT		
0410	Gas Producer Control Actuator (N1 or N2)	Inspect	--			272	27
		Replace	--			272, 282 T115	
		Overhaul			--		
0411	Turbine Control Actuator (N2 or N1)	Inspect	--				27
		Replace	--			T115, 272, 282	
		Overhaul			--		
0412	Engine Condition Control Assembly	Inspect	--			282	
		Replace	--			277	
		Overhaul			--		
041201	Condition Control Panel	Inspect	--				
		Replace	--			277	
041202	Actuator Control Bracket	Inspect	--				
		Replace	--			272, 282	27
0413	Engine Condition Control Resistor (N2)	Inspect	--				
		Adjust	--			272, 282,	27
		Replace	--			277, 282	
0414	Remote Positioning Control Box (N2)	Inspect	--				
		Replace	--			277	27
		Overhaul			--		
0415	Control Box (N1)	Inspect	--				27
		Replace	--			T115, 277	
		Overhaul			--		
0416	Engine Condition Relay and Emergency Trim Relay	Inspect	--				
		Replace	--			277	27
0417	Electrical Harness	Inspect	--				
		Replace	--			272	27, 28
		Repair	--			249 277	

MAINTENANCE ALLOCATION CHART							
Section II							
NOMENCLATURE OF END ITEMS							
(1) Group Number	(2) Component/Assembly	(3) Maintenance Function	(4) Maintenance Category			(5) Tools and Equipment	(6) Remarks
			AVUM	AVIM	DEPOT		
041701	PTIT Wire Harness	Replace	--			272	27, 28
041702	Engine Harness	Inspect	--			311, 312	27, 28
		Repair	--				
0418	Deleted						
0419	Deleted						
0420	Droop Eliminator Variable Resistors	Inspect	--				27
		Adjust	--			T122, T133, 277, 282, T122, 277,	
		Replace	--			282	
		Repair	--			277, 282	
0421	Fuel/Oil Lines	Inspect	--				
		Replace	--			278, 282	
0422	Engine Water Wash System	Inspect	--				
		Replace	--			272	28
		Remove	--			272	
		Install	--			T185	
		Service	--			278	
0423	Water Wash Manifold	Remove	--				
		Install	--			278	28
0424	No. 1 and No. 2 Electronic Control Unit	Inspect	--			186, 268	28
		Replace	--			314	
		Test	--				
0425	Thrust Control Position Transducer Assembly	Inspect	--				
		Remove	--				28
		Install	--			268	
		Adjust	--			T187	
0426	FADEC Control Panel	Inspect	--				
		Remove	--				

MAINTENANCE ALLOCATION CHART							
Section II							
NOMENCLATURE OF END ITEMS							
(1) Group Number	(2) Component/Assembly	(3) Maintenance Function	(4) Maintenance Category			(5) Tools and Equipment	(6) Remarks
			AVUM	AVIM	DEPOT		
NOTE Refer to TM 1-2840-265-23 for other maintenance functions for T55-GA-714A engines.							
NOTE Refer to TM 55-2840-254-23 for other maintenance functions for T55-L-712 engines.							
05	BLADES/ROTOR SYSTEMS						
0501	Blade	Inspect	--				
		Adjust	--			T65	
		Clean	--			T19, T35	
		Replace	--			T47, T48, T70, T77, T79, T85, T86, 264, 278, 282	
		Repair	--	--	--	264, 304	
050101	Blade Trailing Edge	Inspect	--				
		Repair	--			T116, 242, 275	
050102	Blade Tip Cap	Inspect	--				
		Replace	--			278, 282	
		Repair	--				
050103	Blade Leading Edge Erosion Strip	Inspect	--				
		Replace		--		T69, 242, 275	
		Repair	--			T69	
050104	Blade Leading Edge Nose Cap	Inspect	--				
		Replace			--		
		Repair	--			275	
		Repair		--		T19, 275	
050105	Blade Fairing	Inspect	--				
		Repair	--			275, 304	

MAINTENANCE ALLOCATION CHART							
Section II							
NOMENCLATURE OF END ITEMS							
(1) Group Number	(2) Component/Assembly	(3) Maintenance Function	(4) Maintenance Category			(5) Tools and Equipment	(6) Remarks
			AVUM	AVIM	DEPOT		
050106	Trim Tab	Inspect	--				
		Adjust			--		
		Replace			--		
050107	Lag Damper Bracket	Repair	--			275	
		Inspect	--				
		Replace			--		
050107	Lag Damper Bracket Bushings	Repair	--			275	
		Inspect	--			T98	
		Replace	--			278	
050108	Rib Closure Inboard and Outboard	Inspect	--				
		Repair	--	--		275	
				--		242, 275	
050109	Lightning Protection Jumper Wire	Inspect	--				
		Replace	--			275, 282	
05010901	Lightning Protection Jumper Strip	Inspect	--				
		Replace	--			275	
050110	Tiedown Receiver	Inspect	--				
		Replace	--			T25, 275, 282	
050111	Root End Sleeve	Inspect	--				
		Replace			--		
050112	Root End Slot Seal	Inspect	--				
		Repair	--			275	
050113	Blade Spar	Inspect	--				
		Repair	--			275	

MAINTENANCE ALLOCATION CHART							
Section II							
NOMENCLATURE OF END ITEMS							
(1) Group Number	(2) Component/Assembly	(3) Maintenance Function	(4) Maintenance Category			(5) Tools and Equipment	(6) Remarks
			AVUM	AVIM	DEPOT		
0502	Blade Shock Absorber (Damper)	Inspect	--				
		Service	--				
		Test			--		
		Adjust	--			T106, 242, 278	
		Replace	--			278, 282, T98, T35, T72	
		Repair	--			T108, 242, 278	
0503	Rotary Wing Head	Overhaul		--	--		
		Inspect	--			273, 274, 282, 278, T2, T28, T29, T161	
		Service	--				
		Replace	--			T2, T7, T13, T24, T26, T28, T29, T73, 278	
		Repair	--		--	242, 273	
050301	Rotary-Wing Head Tie Bar	Overhaul			--	274, 278	
		Inspect	--				
050302	Fixed Droop Stops	Replace	--			273	
		Inspect	--			274	
050303	Centrifugal Droop Stop Assembly	Replace	--			278, 282	
		Inspect	--			278, 282	
		Adjust	--			278	
		Replace	--			272, 278	
		Repair	--				

MAINTENANCE ALLOCATION CHART							
Section II							
NOMENCLATURE OF END ITEMS							
(1) Group Number	(2) Component/Assembly	(3) Maintenance Function	(4) Maintenance Category			(5) Tools and Equipment	(6) Remarks
			AVUM	AVIM	DEPOT		
050304	Centrifugal Droop Stop Springs and Limiters	Inspect	--			278, 282	
		Replace	--				
050305	Centrifugal Droop Stop Shrouds	Inspect	--			275	
		Replace	--				
		Repair	--				
050306	Centrifugal Droop Stop Shroud Shields and Base	Inspect	--			278	
		Replace	--				
050307	Droop Stop Shroud	Replace	--			278	
NOTE							
AVUM level replacement is limited to removal and reinstallation of the same pitch varying housing.							
0504	Pitch Varying Housing	Inspect	--			23	
		Replace	--	--	--		
050401	Pitch Varying Housing Bearings	Replace			--		
050402	Pitch Varying Housing Bearing Oil Tank	Inspect	--			274	
		Service	--				
		Replace	--				273, 282
		Repair		--			274
050403	Pitch Varying Housing Wear Sleeve	Inspect	--			227, 273	
		Replace	--				
050404	Pitch Varying Housing Oil Seals	Inspect	--			T8, T11, 273	
		Replace	--				
0505	Vertical Hinge Pin	Inspect	--			T79, 275, 282	
		Replace	--				
050501	Vertical Hinge Pin Bearings	Inspect	--			273, 274	
		Replace	--			T10, T102, 242, 273	
050502	Vertical Hinge Pin Bearing Oil Tanks	Inspect	--			273	
		Service	--				
		Replace	--			T33, 273, 282	

MAINTENANCE ALLOCATION CHART							
Section II							
NOMENCLATURE OF END ITEMS							
(1) Group Number	(2) Component/Assembly	(3) Maintenance Function	(4) Maintenance Category			(5) Tools and Equipment	(6) Remarks
			AVUM	AVIM	DEPOT		
050503	Vertical Hinge Pin Oil Seal	Inspect	--			273, 274	
		Replace	--			T10, T12, 273, 274	
050504	Vertical Hinge Pin Oil Manifold Tube	Inspect	--				
		Replace	--			242, 273	
0506	Horizontal Hinge Pin	Inspect	--			274	
		Replace	--			T5, T6, T87, 273, 282	
		Repair			--		
050601	Horizontal Hinge Pin Bearings	Inspect	--			274	
		Replace	--			T5, T6, T9, T87, 273, 282	
050602	Horizontal Hinge Pin Seals	Inspect	--				
		Replace	--			T6, 273	
0507	Pitch Varying Shaft	Inspect	--			274	
		Replace	--				
0508	Hub Oil Tank	Inspect	--			274	
		Service	--				
		Replace	--			278, 282	
		Repair		--		274	
0509	Liquid Sight Indicators and Plugs	Insert	--				
		Replace	--			278, 282	
0510	Swashplate Assembly	Inspect	--			274	
		Service	--				
		Replace	--			T14, 278, 282	
		Repair		--		274, 273	
		Overhaul			--		
0511	Swashplate Bearing	Inspect	--			278, 282	
		Replace		--		238, 273	
0512	Ball (Upper and Lower) Spherical Bearings and Sliding Sleeve Bearings	Inspect	--			274, 278, 282	
		Replace	--			T10, 242, 273	

MAINTENANCE ALLOCATION CHART							
Section II							
NOMENCLATURE OF END ITEMS							
(1) Group Number	(2) Component/Assembly	(3) Maintenance Function	(4) Maintenance Category			(5) Tools and Equipment	(6) Remarks
			AVUM	AVIM	DEPOT		
0513	Spherical Ball	Inspect	--			274	
		Replace	--			242, 273	
		Repair	--	--			
0513	Drive Arms and Drive Collar	Inspect	--				
		Replace	--	--		274, 282	
		Repair	--	--		T30, 274, 238, 241	
0514	Pitch Link	Inspect	--	--		274	
		Adjust	--				
		Replace	--			278, 282	
0515	Weather Protective Cover	Repair	--			T22, T31, T78, 278, 282	
		Inspect	--				
		Replace	--			T78, T105, 242, 274, 278	
0516	Weather Protective Cover Boots	Inspect	--	--			
		Replace	--			278, 282	
		Repair	--	--		201, 242, 275, 304	
06	DRIVE TRAIN SYSTEMS						
0601	Forward Transmission Assembly	Inspect	--				
		Service	--				
		Replace	--			T2, T4, T15, T23, T32, T74, T92, T93, T94, T159, 225, 242, 259, 278	
		Repair	--	--		282	
		Overhaul			--	272, 278	

MAINTENANCE ALLOCATION CHART							
Section II							
NOMENCLATURE OF END ITEMS							
(1) Group Number	(2) Component/Assembly	(3) Maintenance Function	(4) Maintenance Category			(5) Tools and Equipment	(6) Remarks
			AVUM	AVIM	DEPOT		
060101	Forward Transmission Accessory Mounting Seals, Input/Output Shaft Seals	Inspect	--				
		Replace	--			278, 282	
060102	Forward Transmission Oil Level Sight Gage	Inspect	--				
		Replace	--			278, 282	
060103	Forward Transmission Sump	Inspect	--				
		Replace	--			278, 282	
		Repair		--		242, 275	
060104	Forward Transmission Main Lube Pump and Relief Valve	Inspect	--				
		Adjust	--			278	
		Replace	--			278, 282	
		Overhaul			--		
060105	Forward Transmission Auxiliary Lube Pump	Inspect	--				
		Replace	--			278, 282	
		Overhaul			--		
060106	Forward Transmission Filter Elements Main and Aux	Inspect	--				
		Replace	--			278, 282	
060106-01	Forward Transmission Oil Filler Assembly/Screen	Clean	--				
		Inspect	--				
		Replace	--			278	
602	Aft Transmission Assembly	Inspect	--				
		Service	--				
		Replace	--			T17, T23, T37, T43, T49, T50, T85, T160, 225, 259, 278	
		Repair	--			282	
		Overhaul		--		242	

MAINTENANCE ALLOCATION CHART							
Section II							
NOMENCLATURE OF END ITEMS							
(1) Group Number	(2) Component/Assembly	(3) Maintenance Function	(4) Maintenance Category			(5) Tools and Equipment	(6) Remarks
			AVUM	AVIM	DEPOT		
060201	Aft Transmission Accessory Mounting Seals, Input/Output Shaft Seal	Inspect	--				
		Replace	--			273, 282	
060202	Aft Transmission Oil Level Sight Gage	Inspect	--				
		Replace	--			278, 282	
060203	Aft Transmission Sump	Inspect	--				
		Replace	--			278, 282	
		Repair		--		278, 242	
060203-01	Aft Transmission Generator Oil Outlet Screen	Inspect	--				
		Replace	--			278	
60204	Aft Transmission Main Lube Pump and Relief Valve	Inspect	--				
		Adjust	--			278	
		Replace	--			278, 282	
		Overhaul			--		
060205	Aft Transmission Auxiliary Oil Pump	Inspect	--				
		Replace	--			273, 282	
		Overhaul			--		
060205-01	Aft Transmission Oil Filter Assembly/Screen	Clean	--				
		Inspect	--				
		Replace	--			278	
060206	Aft Transmission Filter Elements Main and Aux	Inspect	--				
		Replace	--			278, 282	
060206-01	Aft Transmission Main Oil Filter Pressure Differential Indicator	Inspect	--				
		Replace	--			278	

MAINTENANCE ALLOCATION CHART							
Section II							
NOMENCLATURE OF END ITEMS							
(1) Group Number	(2) Component/Assembly	(3) Maintenance Function	(4) Maintenance Category			(5) Tools and Equipment	(6) Remarks
			AVUM	AVIM	DEPOT		
0603	Combining Transmission Assembly	Inspect	--				
		Service	--				
		Replace	--			T20, T34, T36, 278, 282	
		Repair	--			278, 282	
		Overhaul	--	--	--	278, 282	
060301	Combining Transmission Accessory Mounting Seals Input and Output Shaft Seals	Inspect	--				
		Replace	--			273, 282, 278	
060302	Engine/Combining Transmission Oil Level Sight Gage	Inspect	--				
		Replace	--			278, 282	
060303	Engine/Combining Transmission Oil Pump	Inspect			--		
		Replace			--		
		Repair			--		
060303-01	Engine/Combining Transmission Main Oil Filter Pressure Differential Indicator	Inspect	--				
		Replace	--			278	
060304	Engine/Combining Transmission Oil Filter and Relief Valve Assembly	Inspect	--				
		Adjust	--			278	
		Replace	--				
060304-01	Engine/Combining Transmission Oil Filler Assembly/Screen	Clean	--				
		Inspect	--				
		Replace	--			278	
060305	Engine/Combining Transmission Oil Filter Element	Inspect	--				
		Replace	--			278, 282	

MAINTENANCE ALLOCATION CHART							
Section II							
NOMENCLATURE OF END ITEMS							
(1) Group Number	(2) Component/Assembly	(3) Maintenance Function	(4) Maintenance Category			(5) Tools and Equipment	(6) Remarks
			AVUM	AVIM	DEPOT		
060306	Combining Transmission Auxiliary Bypass Valve	Inspect	--				
		Replace	--			278	
060307	Combining Transmission Sump	Inspect	--				
		Replace	--			278, 282	
		Repair		--		242, 278	
0604	Engine Transmission Assembly	Inspect	--				
		Service	--				
		Replace	--				
		Repair		--			
		Overhaul		--		242	
060401	Engine Transmission Output Shaft Seal	Inspect	--				
		Replace	--			273, 282	
060401-01	Engine Transmission Main Oil Filter Pressure Differential Indicator	Inspect				278	
		Replace	--				
0605	Forward and Aft Slider Shaft Assemblies and Seals	Inspect	--				
		Replace	--			278, 282	
		Repair	--			282	
0606	Transmission Oil Cooler	Inspect	--				
		Test			--		
		Replace	--			278, 282	
		Repair	--			282	
		Overhaul			--		
060601	Oil Cooler Bypass Valve	Inspect	--				
		Test	--				
		Replace	--			278, 282	
0607	Transmission Oil Cooler Fans	Inspect	--			272	
		Replace	--			278, 282	
		Repair			--		24
		Overhaul			--		

MAINTENANCE ALLOCATION CHART							
Section II							
NOMENCLATURE OF END ITEMS							
(1) Group Number	(2) Component/Assembly	(3) Maintenance Function	(4) Maintenance Category			(5) Tools and Equipment	(6) Remarks
			AVUM	AVIM	DEPOT		
060701	Combining Transmission Oil Cooler Fan Shaft Bearings	Inspect	--				
		Service	--				
		Replace		--		242, 278	
060702	Aft Transmission Oil Cooler Fan Shaft Bearings	Inspect	--				
		Replace		--		242, 278	
0608	Transmission Oil Cooler Fan Ducts	Inspect	--				
		Replace	--			278, 282	
		Repair	--				
0609	Drain Valves-Transmission Sump, Tank and Filter	Inspect	--				
		Replace	--			278, 282	
0610	Transmission Indicating Screen/Chip Detector/Temperature Transmitter	Inspect	--				
		Replace	--			278, 282	
		Test	--				
0611	Fittings and Hoses	Inspect	--				
		Replace	--			278, 282	
0612	Transmission Breather	Inspect	--				
		Replace	--			278, 282	
0613	Transmission Oil Screens	Inspect	--				
		Replace	--			278, 282	
0614	Aft Rotor Drive Shaft	Inspect	--				
		Replace	--			T1, T18, T32, 278, 282	
		Repair	--			278, 282	
		Overhaul		--		242, 278	

MAINTENANCE ALLOCATION CHART							
Section II							
NOMENCLATURE OF END ITEMS							
(1) Group Number	(2) Component/Assembly	(3) Maintenance Function	(4) Maintenance Category			(5) Tools and Equipment	(6) Remarks
			AVUM	AVIM	DEPOT		
0615	Drive Shaft Assemblies	Inspect	--			274	
		Service	--				
		Replace	--			278, 282	
		Repair	--			T113, T114, 273, 278, 282	
		Overhaul			--		
0616	Drive Shaft Bearings	Adjust	--			278	
		Inspect	--				
		Service	--				
		Replace	--			273, 282	
		Repair					
0617	Drive Shaft Adapter & Plate Assemblies	Inspect	--			278	
		Replace	--			278, 282	
		Repair	--				
0618	Drive Shaft Mounts and Bushings	Inspect	--				
		Replace	--			278, 282	
0619	Engine Drive Shaft Assembly	Inspect	--				
		Replace	--			278	
		Repair			--		
07	HYDRAULIC SYSTEMS						
0701	System Contamination	Inspect	--				
0702	Flushing Pressure Lines	Service	--			270	
0703	Flushing Return Lines	Service	--			270	
0704	Filling and Bleeding (With External Power)	Service	--			270	
070401	Filling and Bleeding (Without External Power)	Service	--			270	
070402	Tube Bending	Fabricate		--		270, T181	
0705	Tubing	Inspect	--			270, 274	
		Replace	--			270, T181	
		Repair	--			270	

MAINTENANCE ALLOCATION CHART							
Section II							
NOMENCLATURE OF END ITEMS							
(1) Group Number	(2) Component/Assembly	(3) Maintenance Function	(4) Maintenance Category			(5) Tools and Equipment	(6) Remarks
			AVUM	AVIM	DEPOT		
070501	Bulkhead Fittings	Inspect	--				
		Replace	--			270	
0706	Hoses	Inspect	--			270, 274	
		Replace	--			270	
0707	Adapters Rosan	Inspect	--			270.1	
		Replace	--			278, T141.1, T143.1, T143.2, T145.1, T145.2, T145.3, T145.4	
0708	Flight Control No. 1 and No. 2 Power Control Module	Inspect	--				
		Replace	--			278	
070801	Pilot Solenoid Valve	Inspect	--				
		Replace	--			278	
		Repair			--		
070802	High Pressure Relief Valve	Inspect	--				
		Replace	--			278, 282	
070803	Filter Element	Replace	--			278, 301	
070804	Filter Change Switch	Replace	--			278	
070805	Pressure Transmitter	Replace	--			278	
070806	Accumulator	Replace	--			278, 299, 300	
070807	High Pressure Check Valve	Replace	--			278	
070808	Miscellaneous Check Valves	Replace	--			270, 270.1, T150.1, T150.2, T150.3, T152, T152.1, T152.2, T152.3, T152.4, T152.5, T152.6, T152.7, T152.8	

MAINTENANCE ALLOCATION CHART							
Section II							
NOMENCLATURE OF END ITEMS							
(1) Group Number	(2) Component/Assembly	(3) Maintenance Function	(4) Maintenance Category			(5) Tools and Equipment	(6) Remarks
			AVUM	AVIM	DEPOT		
0709	Pivoting and Swiveling Servocylinders	Inspect	--			278	
		Repair		--		270	
		Replace	--			278	
070901	Pivoting and Swiveling Servocylinder Bearings	Inspect	--			233, 242	
				--		270	
		Repair		--		239, 270	
070902	Pressure Indicator	Test	--			278	
070903	Control Valves	Inspect	--			270	
070904	Servocylinder Control Valve Boots	Inspect	--			278, 282	
		Replace	--				
0710	Lower Controls Module No. 1 and No. 2	Inspect	--				
		Replace	--			278	
07001	Solenoid Valve	Inspect	--				
		Replace	--			278, 282	
		Repair			--		
07002	Pressure Reducer Valve	Inspect	--				
		Replace	--			278, 282	
0711	Lower Controls Actuating Cylinder Structural Manifold	Inspect	--				
		Replace	--				
		Repair	--			278, 282	
0712	Integrated Lower Controls Actuator Assembly (ILCA)	Inspect	--			278, 282	
		Test		--		T53, 235, 242, 270	
		Replace	--			278, 282	
		Repair		--			
		Overhaul			--		

MAINTENANCE ALLOCATION CHART							
Section II							
NOMENCLATURE OF END ITEMS							
(1) Group Number	(2) Component/Assembly	(3) Maintenance Function	(4) Maintenance Category			(5) Tools and Equipment	(6) Remarks
			AVUM	AVIM	DEPOT		
071201	Extensible Link	Inspect	--				
		Test	--				
		Replace	--		--	T53, 235, 242, 278	
		Repair		--		278, 282	
		Overhaul			--		
071201-02	Extensible Link Servo Valve	Inspect	--				
		Replace		--		266, 270	
071201-03	Extensible Link Pressure Port Filter	Inspect	--				
		Replace	--			278	
071202	Cross Feedback Transducer	Inspect	--				
		Test	--			T51, 278, 282	
		Adjust	--		--	T51, T53	
071203	Self Feedback Transducer	Replace		--		T51, 278, T53, 242, 270	
		Inspect	--			242, 278	
		Test	--			T51	
		Adjust		--		T53, 235, 270, 278, T53, 235, 265, 266, 270	
		Replace			--	236, 265, 266, 270, T53	

MAINTENANCE ALLOCATION CHART							
Section II							
NOMENCLATURE OF END ITEMS							
(1) Group Number	(2) Component/Assembly	(3) Maintenance Function	(4) Maintenance Category			(5) Tools and Equipment	(6) Remarks
			AVUM	AVIM	DEPOT		
071204	Jam Sensor	Inspect	--				
		Test	--				
071205	Relief Valve	Replace	--	--		T53, 235, 242, 270	
		Inspect	--			278	
071206	Check Valve	Test		--		T53, 235, 242, 278	
		Replace		--		278	
071207	Servo Valve	Inspect	--				
		Test	--				
0713	No. 1 or No. 2 Flight Control Reservoir/Cooler	Replace		--		T53, 235, 242, 278	
		Repair			--	266, 278	
071301	Temperature Switch	Inspect	--				
		Test	--			274	
071302	Relief Valve	Service	--				
		Test	--			235, 236, 242, 270, 284	
071303	Bleed and Relief Valve	Replace	--			278, 282	
		Repair		--		235, 242, 270, 274	
071301	Temperature Switch	Inspect	--				
071302	Relief Valve	Replace	--			278	
071303	Bleed and Relief Valve	Inspect	--				
071303	Bleed and Relief Valve	Replace	--			278	

MAINTENANCE ALLOCATION CHART							
Section II							
NOMENCLATURE OF END ITEMS							
(1) Group Number	(2) Component/Assembly	(3) Maintenance Function	(4) Maintenance Category			(5) Tools and Equipment	(6) Remarks
			AVUM	AVIM	DEPOT		
071304	Temperature Bulb	Inspect	--				
		Replace	--			278	
0714	No. 1 or No. 2 Flight Control Reservoir/Cooler Fan	Inspect	--				
		Test			--	235, 236, 238, 242, 249, 252, 277	
		Replace	--			278	
		Repair			--	236, 242, 274, 277	
		Overhaul			--		
0715	No. 1 or No. 2 Flight Control Pump	Inspect	--				
		Service		--		242, 270	
		Test		--		235, 270	
		Replace	--			278, 282	
		Repair			--	235, 242, 270	
0716	APU Start Module	Inspect	--				
		Replace	--			278, 282	
071601	Accumulator	Inspect	--				
		Service		--		270, 274	
		Test		--		T159, 211, 215, 235, 270	
		Replace	--			278, 282	
		Repair			--	235, 242, 270, 274	
071602	Start Valve	Inspect	--				
		Replace	--			278	
		Repair			--		
071603	Check and Depressurization Valve	Inspect	--				
		Replace	--			278	

MAINTENANCE ALLOCATION CHART							
Section II							
NOMENCLATURE OF END ITEMS							
(1) Group Number	(2) Component/Assembly	(3) Maintenance Function	(4) Maintenance Category			(5) Tools and Equipment	(6) Remarks
			AVUM	AVIM	DEPOT		
071604	Solenoid Start Pilot Valve	Inspect	--			278, 282	
		Replace	--				
		Repair			--		
0717	APU Start Accumulator	Inspect	--			278, 282	
		Service	--				
		Test			--		
		Replace	--				
071701	APU Start Accumulator Air Charging Valve and Pressure Gage	Inspect	--			278	
		Replace	--				
071702	APU Start Accumulator Transfer Tubes	Inspect	--			278	
		Replace	--				
071703	APU Start Accumulator Mounting Plate	Inspect	--			270	
		Replace	--				
0718	Pressure Control Module	Inspect	--			278, 282	
		Replace	--				
071801	Filter	Inspect	--			278	
		Replace	--				
071802	Filter Indicator	Inspect	--			278, 282	
		Replace	--				
071803	High Pressure Relief Valve	Inspect	--			278	
		Replace	--				
071804	Pressure Transmitter	Inspect	--			278	
		Replace	--				
071805	Three-way Solenoid Valve	Inspect	--			278	
		Replace	--				
		Repair			--		
071806	Check Valve	Inspect	--			278	
		Replace	--				

MAINTENANCE ALLOCATION CHART

Section II

NOMENCLATURE OF END ITEMS

(1) Group Number	(2) Component/Assembly	(3) Maintenance Function	(4) Maintenance Category			(5) Tools and Equipment	(6) Remarks
			AVUM	AVIM	DEPOT		
071807	Utility System Pressure Switch	Replace	--			278	
071808	Pilot Valve	Inspect	--				
		Replace	--			278, 282	
		Repair			--		
071809	PTU Valve	Inspect	--				
		Replace	--			278	
		Repair			--		
0719	Engine Start Valve	Inspect	--				
		Replace	--			278, 282	
		Repair			--		
0720	Return Control Module	Inspect	--				
		Replace	--			278, 282	
072001	Transfer Cylinder	Inspect	--				
				--		270, 274	
		Test		--		T56, 235, 270	
		Replace	--			278, 282	
		Repair		--		235, 242, 270, 274	
072002	Filter Indicator	Inspect	--				
		Replace	--			278, 282	
072003	Filter By-Pass Valve	Inspect	--				
		Replace	--			278	
072004	Transfer Cylinder Check Valve	Inspect	--				
		Replace	--			278	
072005	Filter check Valve	Inspect	--				
		Replace	--			278	
072006	Filter	Inspect	--				
		Replace	--			278, 282	
072007	APU or Utility Pump Fail Indicator	Inspect	--				
		Replace	--			278	
0721	No 1 or No 2 Power Transfer Unit Module	Inspect	--				
		Replace	--			278, 282	

MAINTENANCE ALLOCATION CHART							
Section II							
NOMENCLATURE OF END ITEMS							
(1) Group Number	(2) Component/Assembly	(3) Maintenance Function	(4) Maintenance Category			(5) Tools and Equipment	(6) Remarks
			AVUM	AVIM	DEPOT		
072101	Hydraulic Motor and Pump	Inspect	--				
		Test		--		T118, 235, 270	
		Replace	--			278	
		Repair		--		270	
		Overhaul			--		
072101-01	Motor or Pump Shaft Seal	Inspect	--				
		Replace	--			235, 270, 274, 282	
072102	Three-Way Valve	Inspect	--				
		Replace	--			278	
072103	Check Valve	Inspect	--				
		Replace	--			278	
072104	Pilot Solenoid Valve	Inspect	--				
		Replace	--			278	
		Repair			--		
072105	Flow Limiter	Inspect	--				
		Replace	--			278	
0722	Hand Pump	Inspect	--				
		Replace	--			242, 270, 278	
0723	Hydraulic Fill Module	Inspect	--			274, 282	
		Test		--		212, 216, 235, 242, 270	
		Replace	--			278, 282	
		Repair	--		--	278	
					--	242, 270, 274, 278, 282	

MAINTENANCE ALLOCATION CHART							
Section II							
NOMENCLATURE OF END ITEMS							
(1) Group Number	(2) Component/Assembly	(3) Maintenance Function	(4) Maintenance Category			(5) Tools and Equipment	(6) Remarks
			AVUM	AVIM	DEPOT		
0724	Engine Starter Motor	Inspect	--	--			
		Test		--			
		Replace	--			278	
		Repair		--			
		Overhaul			--		
0725	APU Motor, Pump	Inspect	--	--			
		Test		--		235, 270	
		Replace	--			278	
		Repair		--		242, 270	
						--	
0726	Utility Pump	Inspect	--	--			
		Test		--			
		Replace	--			278, 282	
		Repair		--		270	
						--	
0727	Utility Reservoir/Cooler	Inspect	--	--		274	
		Service	--				
		Test		--		235, 236, 242, 270, 284	
		Replace	--			278, 282	
		Repair		--		235, 242, 270, 274	
						--	
072701	Relief Valve	Inspect	--				
		Replace	--			278	
072702	Temperature Bulb	Inspect	--				
		Replace	--			278	
072703	Temperature Switch	Inspect	--				
		Replace	--			278	

MAINTENANCE ALLOCATION CHART								
Section II								
NOMENCLATURE OF END ITEMS								
(1) Group Number	(2) Component/Assembly	(3) Maintenance Function	(4) Maintenance Category			(5) Tools and Equipment	(6) Remarks	
			AVUM	AVIM	DEPOT			
072704	Bleed/Relief Valve	Inspect	--					
		Replace	--			278		
0728	Utility Reservoir/Cooler Fan	Inspect	--					
		Test			--	235, 236, 238, 242, 249, 252, 277		
		Replace	--				278	
		Repair			--		236, 242, 274, 277	
		Overhaul			--			
0729	Winch Motor	Inspect	--					
		Replace	--				278	
0730	Hoist Control Valve	Inspect	--					
		Replace	--				278	
		Overhaul			--			
0731	Hoist Pressure Reducing Valve	Inspect	--				270, 274	
		Test		--			210, 211, 214, 235, 242, 270	
		Replace	--				270	
		Repair		--			242, 270	
0732	Hoist Control Relief Valve	Inspect	--					
		Replace	--				278	
0733	Hoist Control Shutoff Check Valve	Inspect	--					
		Replace	--				278	
0734	Brake Master Cylinder	Inspect	--					
				--			274	
		Test		--			214, 235, 270, 287, 288, 289, 290	
		Replace	--				278, 282	
		Repair		--		235, 242, 270, 274, 296		

MAINTENANCE ALLOCATION CHART							
Section II							
NOMENCLATURE OF END ITEMS							
(1) Group Number	(2) Component/Assembly	(3) Maintenance Function	(4) Maintenance Category			(5) Tools and Equipment	(6) Remarks
			AVUM	AVIM	DEPOT		
0735	Parking Brake Valve	Inspect	--				
		Replace	--			278	
0736	Parking Brake	Inspect	--				
		Adjust	--			278, 282	
0737	Brake Pressure Reducing Valve	Inspect	--				
		Test		--		210, 211, 214, 235, 242, 270	
		Replace	--			270	
		Repair		--		242, 270	
0738	Brake Transfer Valves	Inspect	--				270, 274, 282
		Test		--		214, 235, 270	
		Replace	--			278	
		Repair		--		235, 242, 270	
0739	Emergency Brake Accumulator	Inspect	--				270, 274, 282
		Service	--			242, 270, 274, 302	
		Test		--		278	
		Replace	--			212, 235	
		Repair	--			270	
0740	Power Steering and Swivel Lock Module	Inspect	--				278, 235, 242, 270, 274
		Replace	--			278, 282	
074001	Solenoid Control Valve	Inspect	--				
		Replace	--			278, 282	
		Repair			--		
074002	Check Valve	Inspect	--				
		Replace	--			278	

MAINTENANCE ALLOCATION CHART							
Section II							
NOMENCLATURE OF END ITEMS							
(1) Group Number	(2) Component/Assembly	(3) Maintenance Function	(4) Maintenance Category			(5) Tools and Equipment	(6) Remarks
			AVUM	AVIM	DEPOT		
074003	Accumulator	Inspect	--	--		270, 274	
		Service	--				
		Test		--		T159, 211, 215, 235, 270	
		Replace	--			278, 282	
		Repair		--		235, 242, 270, 274	
0741	Power Steering Assembly	Inspect	--				
		Test	--				
		Replace	--			278, 282	
		Repair		--			
		Overhaul			--		
074101	Servo Valve	Inspect	--				
		Replace	--			278	
074102	Out-of-Phase Switch	Inspect	--				
		Adjust	--			278	
		Replace	--			278	
074103	Pressure Tube	Inspect		--		274	
		Replace		--		274, 278	
0742	Cargo Hook Release Valve	Inspect	--				
0743	Ramp Actuating Cylinder			--		242, 274	
		Test		--		214, 235, 236, 270	
		Replace	--			278	
		Repair		--		242, 270	
		Inspect	--				
		Adjust	--			278, 282	
		Replace	--			278, 282	
Repair		--		221, 242, 270			
		Overhaul			--		

MAINTENANCE ALLOCATION CHART							
Section II							
NOMENCLATURE OF END ITEMS							
(1) Group Number	(2) Component/Assembly	(3) Maintenance Function	(4) Maintenance Category			(5) Tools and Equipment	(6) Remarks
			AVUM	AVIM	DEPOT		
0744	Ramp Control Valve						
074401	Ramp Control Valve Without 65	Inspect	--	--		274	
		Test		--		214, 235, 242, 270	
		Replace	--			278	
		Repair		--		235, 242, 270, 274	
074402	Ramp Control Valve With 65	Inspect	--	--		274	
		Test		--		T178, T179, 214, 235, 242, 270	
		Replace	--			278	
		Repair		--		T173, T174, T175, T176, T177, 235, 242, 270, 274	
0745	Cargo Door Sequence Valve	Inspect	--	--		242, 274	
		Test		--		208, 209, 235, 270	
		Adjust	--			278	
		Replace	--			278	
		Repair		--		235, 270	
0746	Cargo Door Pressure Actuated Valve	Inspect	--			274	
		Replace	--			278	
		Repair	--			270	
		Test	--			270	
0747	Motor, Cargo Door	Inspect	--				
		Test		--		235, 270	
		Replace	--			278, 282	
		Repair		--		235, 242, 270	
		Overhaul		--			

MAINTENANCE ALLOCATION CHART							
Section II							
NOMENCLATURE OF END ITEMS							
(1) Group Number	(2) Component/Assembly	(3) Maintenance Function	(4) Maintenance Category			(5) Tools and Equipment	(6) Remarks
			AVUM	AVIM	DEPOT		
0748	Swivel Lock Actuator	Inspect	--	--		242, 274	
		Test		--		235, 270	
		Replace	--			278	
		Repair		--		235, 242, 270	
08	INSTRUMENT SYSTEMS						
0801	Engine Oil, Transmission Oil, Hydraulic Pressure Transmitters and Switches	Inspect	--				
		Replace	--			277, 278, 281, 282, 272	
080101	Engine Oil Pressure Transmitter Vibration Clamps and Mounts	Replace	--			272, 278	
0802	Transmission Oil Temperature Transmitters	Inspect	--				
		Replace	--			278, 281, 282	
0803	Engine Transmission Chip Detector/Temp Switch	Inspect	--			278	
		Test	--			T101, T111, 282	
		Replace	--			278	
0804	Cruise Guide Indicator	Inspect	--				
		Test	--				
		Replace	--			277	
080401	Signal Processor/Conditioner	Inspect	--				
		Test	--				
		Replace	--			277	
		Repair			--		
080402	Strain Gage	Inspect	--				
		Test		--	--		
		Replace	--				13
		Repair			--		

MAINTENANCE ALLOCATION CHART							
Section II							
NOMENCLATURE OF END ITEMS							
(1) Group Number	(2) Component/Assembly	(3) Maintenance Function	(4) Maintenance Category			(5) Tools and Equipment	(6) Remarks
			AVUM	AVIM	DEPOT		
0805	Rotor Tachometer Indicator	Inspect	--				
		Replace	--			278	
		Overhaul			--		
0805.1	Rotor Tachometer Capacitor	Replace		--		277	
0806	Transmission Oil Pressure Indicator and Switch	Inspect	--				
		Test		--		235, 236, 242, 277	
		Replace	--			278	
		Overhaul			--		
0807	Transmission Oil Temperature Indicator and Switch	Inspect	--				
		Test		--		235, 236, 242, 277	
		Replace	--			278	
		Overhaul			--		
0808	Hydraulic Temperature Indicator	Inspect	--				
		Test		--		236, 257, 277	
		Replace	--				
0809	Hydraulic Temperature Probe	Inspect	--				
		Replace	--			278	
0810	Hydraulic Pressure Indicator	Inspect	--				
		Test	--			236, 277, 285	
		Replace	--				
		Overhaul			--		
0811	Hydraulic Fluid Level Indicator/Signal Conditioner	Inspect	--				
		Test	--			255, 277	
		Replace	--			278	
		Overhaul			--		
0812	Hydraulic Fluid Level Transmitter (LDVT)	Inspect	--				
		Replace	--			277	

MAINTENANCE ALLOCATION CHART							
Section II							
NOMENCLATURE OF END ITEMS							
(1) Group Number	(2) Component/Assembly	(3) Maintenance Function	(4) Maintenance Category			(5) Tools and Equipment	(6) Remarks
			AVUM	AVIM	DEPOT		
0813	Vertical Velocity Indicator	Inspect	--				
		Replace	--			277	
		Overhaul			--		
0814	Fuel Quantity Indicator	Inspect	--				
		Test	--			T158, 277, 183, 184	
		Adjust	--			T158, 277	
		Replace	--			277	
		Overhaul			--		
0815	Fuel Quantity Selector Switch	Inspect	--				
		Replace	--			278	
081501	Fuel Quantity Switch Box	Inspect	--				
		Install	--			277	
		Remove	--			277	
0816	Fuel Quantity Tank Unit	Inspect	--				
		Test	--			T158, 277, 183, 184	
		Adjust	--			T158, 277	
		Adjust	--			277, 281	
		Replace	--			282	
0817	Mounts, Cables, Quick-Disconnects	Inspect	--				
		Replace	--			277, 282	
		Repair	--				
0818	Fuel Flow Transmitter	Inspect					
		Test		--		T158	
		Replace	--			278	
0819	Low Fuel Sensor	Inspect	--				
		Test	--	--			
		Replace		--		278	
0820	High Fuel Sensor	Inspect	--				
		Test	--	--			
		Replace		--		278	

MAINTENANCE ALLOCATION CHART							
Section II							
NOMENCLATURE OF END ITEMS							
(1) Group Number	(2) Component/Assembly	(3) Maintenance Function	(4) Maintenance Category			(5) Tools and Equipment	(6) Remarks
			AVUM	AVIM	DEPOT		
0821	Fuel Thermistor Control Unit	Inspect	--				
		Adjust	--				
		Replace	--			277	
0822	Deleted						
0822.1	Clock Aircraft Digital	Inspect	--				
		Replace	--			278	
0823	Compass, Magnetic	Inspect	--				
		Test	--				
		Adjust	--				
		Replace	--			271, 281	
082301	Compass Bracket	Replace	--			271	
0824	Attitude Indicator	Inspect	--				9
		Test	--			268	9
		Replace	--			268	9
		Overhaul			--		
0825	Turn and Slip Indicator	Inspect	--				
		Replace	--			277	
		Overhaul			--		
0826	Airspeed Indicator and Restrictor	Inspect	--				
		Test	--			T27, 236, 271	
		Adjust	--			T27, 236, 271, 298	
		Replace	--			277	
0827	Barometric Altimeter	Inspect	--				
		Test	--			277	
		Replace	--			277	
		Overhaul			--		
0828	AIMS Altimeter	Inspect	--				9
		Test	--			278	9
		Replace	--			278	9
		Overhaul			--		

MAINTENANCE ALLOCATION CHART							
Section II							
NOMENCLATURE OF END ITEMS							
(1) Group Number	(2) Component/Assembly	(3) Maintenance Function	(4) Maintenance Category			(5) Tools and Equipment	(6) Remarks
			AVUM	AVIM	DEPOT		
0829	Free Air Thermometer	Inspect	--				
		Test	--			257, 277	
		Replace	--			278	
0830	Gas Producer Tachometer Indicator	Inspect	--				
		Test	--			254, 277	27, 28
		Replace	--			278	
083001	No. 1 or No. 2 Power Turbine and Gas Producer Magnetic Pickup	Inspect	--				
		Replace	--			272	28
0831	Tachometer Generator	Inspect	--				27
		Test	--			254, 277	
		Replace	--			272	
0832	PTIT Indicator	Inspect	--				
		Test	--			T101, T104, 277, 282, 277	27, 28
		Adjust	--				
		Replace	--				
		Overhaul			--		
0833	Engine Oil Temperature Indicator	Inspect	--				27, 28
		Test	--			257, 277	
		Replace	--			278	
0834	Engine Oil Temperature Transmitter (Bulb)	Inspect	--				
		Replace	--			272	27
083401	Engine Oil Temperature Transmitter Probe	Inspect	--				
		Replace	--			272	28
0835	Engine Oil Pressure Indicator	Inspect	--				
		Test	--			253, 277	27, 28
		Replace	--				

MAINTENANCE ALLOCATION CHART							
Section II							
NOMENCLATURE OF END ITEMS							
(1) Group Number	(2) Component/Assembly	(3) Maintenance Function	(4) Maintenance Category			(5) Tools and Equipment	(6) Remarks
			AVUM	AVIM	DEPOT		
0836	Engine Torque Indicator	Inspect	--				
		Test		--		236, 255, 277	27
		Adjust	--				
		Replace	--			278	
		Overhaul			--		
083601	Engine Torque Indicator	Inspect	--				
		Test		--		236, 277, T188	28
		Adjust	--				
		Replace	--			278	
		Overhaul			--		
083602	No. 1 or No. 2 Torque Signal Processor/Power Supply	Inspect/Set Codes	--			277	28
		Remove	--			277	
		Install	--			277	
083603	Torque Sensor	Inspect	--				
		Remove	--			277	28
		Install	--			277	
083604	Junction Box (J-Box)	Inspect	--			277	
		Replace	--			277	28
		Test	--			277, T188	
0837	Power Supply, Engine Torquemeter	Inspect	--				
		Test		--		207, 236, 277, 283	27
		Replace	--			278	
		Overhaul			--		
0838	Pitot-Static and Sideslip Sensing System	Inspect	--			277	
		Test	--			277	
		Replace	--			234, 275, 277, 278	
083801	Pitot Static/Sideslip Tubing	Replace	--				
		Repair	--			277	

MAINTENANCE ALLOCATION CHART							
Section II							
NOMENCLATURE OF END ITEMS							
(1) Group Number	(2) Component/Assembly	(3) Maintenance Function	(4) Maintenance Category			(5) Tools and Equipment	(6) Remarks
			AVUM	AVIM	DEPOT		
0839	Cyclic Trim Indicator	Inspect	--				
		Test	--			244, 277	
		Replace	--			278	
0840	Maintenance Panel	Inspect	--				
		Replace	--			256, 266, 277	
		Repair	--			256, 266, 277	
0841	Indicator, Magnetic	Inspect	--				
		Replace	--			256, 277	
0842	Indicator, Light	Inspect	--				
		Replace	--			277	
0843	Instrument Panels	Inspect	--				
		Replace	--			266, 277	
		Repair	--			278	
084301	Instrument Panel Lights	Replace	--			277	
0844	Light, Emergency Power	Inspect	--				27
		Test	--				
		Replace	--			277	
0845	Switches, Emergency Power	Inspect	--				27
		Test	--				
		Replace	--			277	
09	ELECTRICAL SYSTEMS						
0901	Main Generator	Inspect	--				
		Replace	--			277	
		Overhaul			--		
0902	Main Generator Control Panel	Inspect	--				
		Replace	--			278	
		Overhaul			--		
0903	Emergency Power Panel	Inspect	--				27
		Test		--		242, 277	
		Replace	--			278	
		Repair		--		242, 277	

MAINTENANCE ALLOCATION CHART							
Section II							
NOMENCLATURE OF END ITEMS							
(1) Group Number	(2) Component/Assembly	(3) Maintenance Function	(4) Maintenance Category			(5) Tools and Equipment	(6) Remarks
			AVUM	AVIM	DEPOT		
0904	APU Generator	Inspect	--			277	14
		Replace	--				
		Repair	--				
		Overhaul			--		
0905	APU Generator Control Panel	Inspect	--			277	
		Replace	--				
		Overhaul			--		
090501	APU Generator Relay	Inspect	--			277	
		Replace	--				
0906	APU Control Box (ESU)	Inspect	--			277	
		Replace	--				
		Repair			--		
		Overhaul			--		
0907	DC Power Supplies	Inspect	--			277	
		Replace	--				
		Repair		--			
		Overhaul			--		
0908	Contactor, Main Line	Inspect	--			277	
		Replace	--				
0909	Battery	Inspect	--			277	
		Service		--			
		Replace	--				
		Repair		--			
090901	Battery Cables	Inspect	--			276, 277	
		Test		--			
		Replace		--			
		Repair		--			
		Service		--			
0910	Battery Sump Jar	Inspect	--			277	
		Service	--				
		Replace	--				

MAINTENANCE ALLOCATION CHART							
Section II							
NOMENCLATURE OF END ITEMS							
(1) Group Number	(2) Component/Assembly	(3) Maintenance Function	(4) Maintenance Category			(5) Tools and Equipment	(6) Remarks
			AVUM	AVIM	DEPOT		
0911	Battery Charger	Inspect	--				
		Replace	--			277	
		Repair			--		
091101	Battery Relay	Inspect	--				
		Replace	--			277	
0912	Power Monitor	Inspect	--				
		Replace	--			277	
0913	Relays, Transformers	Inspect	--				
		Replace	--			277	
0914	Switches, Circuit Breakers, and Fuses	Inspect	--				
		Replace	--			277	
0915	Terminal Board Module	Inspect	--				
		Replace	--			266, 277	
0916	Ground Device Module	Inspect	--				
		Replace	--			266, 277	
0917	Control Stick and Thrust Control Grip Assemblies	Inspect	--				
		Test	--			236	
		Replace	--			265, 266, 277	
		Repair	--			277, 282	
0918	Landing Searchlights			--		236, 277	
		Inspect	--				
		Test	--				
		Test NVG		--		236, 277	
		Adjust		--		277	
		Replace	--			278	
		Repair	--			277	
0919	Floodlight			--		277	
		Inspect	--				
		Replace	--			277, 282	

MAINTENANCE ALLOCATION CHART							
Section II							
NOMENCLATURE OF END ITEMS							
(1) Group Number	(2) Component/Assembly	(3) Maintenance Function	(4) Maintenance Category			(5) Tools and Equipment	(6) Remarks
			AVUM	AVIM	DEPOT		
0920	Anticollision Lights	Inspect	--			277	
		Test	--				
		Replace	--	--		235, 236	
		Repair		--		277 236, 242, 277	
0921	Interior Lights, Navigation Lights, Switches, and Formation Lights	Inspect	--				
		Test	--				
		Replace	--			277, 282	
		Repair	--			277	
0922	Troop Warning Box	Inspect	--				
		Replace	--			277, 278	
		Repair	--			277, 278	
0923	Master Caution Panel	Inspect	--				
		Test		--		277	
		Replace	--			277	
		Repair	--			277 277	
092301	Caution Panel NVG Filter	Inspect	--				27
		Repair	--			277	
		Replace	--			277	
0924	Console Components	Inspect	--				
		Replace	--			277, 282	
0925	Power Steering Control Box	Inspect	--				
		Test	--			277	
				--		236	
		Adjust	--			277	
				--		236	
		Replace	--			277	
				--	236, 242, 265, 277		

MAINTENANCE ALLOCATION CHART							
Section II							
NOMENCLATURE OF END ITEMS							
(1) Group Number	(2) Component/Assembly	(3) Maintenance Function	(4) Maintenance Category			(5) Tools and Equipment	(6) Remarks
			AVUM	AVIM	DEPOT		
0926	Overhead Panel	Inspect	--				
		Replace	--			266, 277	
		Repair	--			277	
092601	Overhead Panel Transformers and Relay	Inspect	--				
		Replace	--			277	
092602	Overhead Panel Transformer Fuses	Inspect	--				
		Replace	--			277	
0927	Cables and Connectors	Inspect	--				
		Replace	--			277, 282	
		Repair	--			249, 265, 266, 277, 282	
0928	Variable Resistors or Control Transformers	Inspect	--				
		Replace	--			277, 282	
0929	Lamps and Lenses	Inspect	--				
		Replace	--			277, 282	
0930	Grip, Winch Control	Inspect	--				
		Test	--			277, 236	
		Replace	--	--		277	
		Repair	--	--		236, 277	
0931	External Power Control Relay	Inspect	--				
		Replace	--			277	
0933	Dual Hook Relay Box	Inspect	--			277	
		Test	--			277, 282	
		Replace	--	--		236, 277, 282	
		Repair	--	--		277, 236, 266, 277	

MAINTENANCE ALLOCATION CHART							
Section II							
NOMENCLATURE OF END ITEMS							
(1) Group Number	(2) Component/Assembly	(3) Maintenance Function	(4) Maintenance Category			(5) Tools and Equipment	(6) Remarks
			AVUM	AVIM	DEPOT		
0934	Emergency Hook Release Relay Box	Inspect	--				
		Test	--			277, 282	
		Replace	--			235, 282, 277	
		Repair	--			277	
0935	Alarm Bell and Troop Warning	Inspect	--			218, 236, 266, 277	
		Replace	--			277, 282	
		Repair	--			277, 282	
0936	Avionics Cooling Fan	Inspect	--			274	
		Test	--			236, 249, 252	
		Replace	--			265, 277	
		Repair	--			236, 242, 277, 278	
0937	Power Distribution Panel	Inspect	--				
		Replace	--			277	
0938	Control Unit Level Sensing	Inspect	--				
		Replace	--				
		Repair	--		--		
10	FUEL SYSTEM						
1001	Fuel System	Test	--			278, 282	
		Bleed	--			278, 282	
100101	Flushing	Service	--			278	
1002	Fuel Tanks	Inspect	--				
		Purge	--			200, 219, 282, 278	
		Service	--				
		Test	--			223, 235, 278, 282	
		Replace	--			278, 282, 297	
		Repair	--				

MAINTENANCE ALLOCATION CHART							
Section II							
NOMENCLATURE OF END ITEMS							
(1) Group Number	(2) Component/Assembly	(3) Maintenance Function	(4) Maintenance Category			(5) Tools and Equipment	(6) Remarks
			AVUM	AVIM	DEPOT		
100201	Vent Fairing	Inspect	--				
		Replace	--			278	
1003	Fuel Cell	Inspect	--				
		Test	--			217, 223, 278	
		Replace	--			278, 282	
		Repair	--			278	
1004	Fuel Tank Vent Components	Inspect	--				
		Test	--			T158, 278, 282	
		Replace	--			278	
1005	Filler Caps	Inspect	--				
		Replace	--			278	
1006	Fuel Booster Pumps	Inspect	--				
		Replace	--			278, 282, 297	
		Overhaul			--		
1007	Fuel System Pressure Switches	Inspect	--				
		Replace	--			278	
1008	Fuel Check Valves	Inspect	--				
		Replace	--			278, 282, 297	
1009	Defueling Valve	Inspect	--				
		Replace	--			278, 282	
1010	Tank Unit Wire Harness	Inspect	--				
		Replace	--			278, 282	
1011	Booster Pump Relays	Inspect	--				
		Replace	--			278	
1012	APU Fuel Boost Pump	Inspect	--				
		Replace	--			278	
1013	APU Fuel Shutoff Valve, Manual	Inspect	--				
		Replace	--			278	

MAINTENANCE ALLOCATION CHART							
Section II							
NOMENCLATURE OF END ITEMS							
(1) Group Number	(2) Component/Assembly	(3) Maintenance Function	(4) Maintenance Category			(5) Tools and Equipment	(6) Remarks
			AVUM	AVIM	DEPOT		
1014	Drain Valves	Inspect	--				
		Replace	--			278, 282	
		Repair		--		278	
1015	Fuel Gate Valves	Inspect	--				
		Test	--				
		Replace	--			278, 282	
1016	Lines and Fittings	Overhaul			--		
		Inspect	--				
		Replace	--			278, 282	
1017	Filters, Strainers, and Screens	Inspect	--				
		Replace	--			278, 282	
1018	Fuel Level Shutoff Valve	Inspect	--				
		Replace	--			278, 282	
		Repair			--		
1019	Fuel Crossfeed Valve	Inspect	--				
		Test	--				
		Replace	--			278, 282	
		Overhaul			--		
1020	Fuel Level Control Valve	Inspect	--				
		Replace	--			278	
		Repair			--		
1021	APU Fuel Solenoid Valve	Inspect	--			278	
		Replace	--			278	
1022	Jet Pump	Inspect	--				
		Replace	--			278	
1023	Fuel Precheck Panel	Inspect	--				
		Replace	--			278	
		Repair		--		277	
1024	Pressure Refueling Adapter	Inspect	--				
		Replace	--			278	
		Repair	--			278	

MAINTENANCE ALLOCATION CHART								
Section II								
NOMENCLATURE OF END ITEMS								
(1) Group Number	(2) Component/Assembly	(3) Maintenance Function	(4) Maintenance Category			(5) Tools and Equipment	(6) Remarks	
			AVUM	AVIM	DEPOT			
1025	Fuel Quantity Inverter	Inspect	--					
		Replace	--			278		
1026	Suction Feed Check Valve	Inspect	--					
		Replace	--			278		
1027	Engine Fuel Shutoff Valve	Inspect	--					
		Replace	--			278, 282		
11	FLIGHT CONTROL SYSTEMS							
1101	Dash Actuator Assembly	Inspect	--					
		Test	--			T51		
				--			T51	
		Adjust	--				T41, T42, T130, 278, 282	
		Replace	--				T42, T130 278, 282	
		Repair		--				
1102	Longitudinal Cyclic Trim (LCT) Actuator	Overhaul			--			
		Inspect	--					
		Test	--					
				--			242, 278	
		Adjust	--					
				--			242, 278	
110201	LCT Variable Resistor	Replace	--				278, 282	
		Repair		--			221, 242, 278	
		Overhaul			--			
		Inspect	--	--				
110202	LCT Actuator Motor	Replace	--				277	
			--				277, 282	

MAINTENANCE ALLOCATION CHART							
Section II							
NOMENCLATURE OF END ITEMS							
(1) Group Number	(2) Component/Assembly	(3) Maintenance Function	(4) Maintenance Category			(5) Tools and Equipment	(6) Remarks
			AVUM	AVIM	DEPOT		
1103	AFCS Computer	Inspect	--				
		Test	--			T51, 277, 278	
		Replace	--	--		T27, T52, 236, 277	
		Repair	--	--		278	
110301	AFCS Roll Erection Cutout Relay	Install	--			278	
		Remove	--			278	
110302	Sideslip/Airspeed/Barometric Pressure Transducers	Test		--		T27, 278	
		Adjust	--			T27, 278	
1104	AFCS Computer Circuit Boards	Inspect	--			T27, T52, 278	
		Replace		--		269	
110401	Closet Control Pallets	Inspect	--			275	
		Repair	--				
		Replace	--				
1105	Balance Springs	Inspect	--				
		Adjust	--			278, 282	
		Replace	--			278, 282	
1106	Cockpit Control Assemblies and Interconnecting Links	Inspect	--			274	
		Adjust	--			T89, T72, T122, T125, T127, 278, 282	
		Replace	--			T81, T89, T72, T119, T120, T121, T122, T123, T124, T125, T126, T127,	
		Repair	--			278, 282, 239, 242, 278	

MAINTENANCE ALLOCATION CHART							
Section II							
NOMENCLATURE OF END ITEMS							
(1) Group Number	(2) Component/Assembly	(3) Maintenance Function	(4) Maintenance Category			(5) Tools and Equipment	(6) Remarks
			AVUM	AVIM	DEPOT		
1107	Flight Control Connecting Links	Inspect	--			274	
		Adjust	--			T44, 278	
		Replace	--			T44, 278, 282	
		Repair	--			278	
1108	Link, Idler	Inspect	--	--		242	
		Adjust	--				
		Replace	--			278, 282	
		Repair	--			278	
1109	Control Pallets	Inspect	--				
		Adjust	--			T128, T133, 278, 282	
		Replace	--			T128, T133, 278, 282	
110901	Control Pallet Idler Bellcranks	Inspect	--				
		Adjust	--			T128, T133 278, 282	
		Replace	--			T128, T133	
		Repair		--			
1110	Thrust Detent Capsule	Inspect	--				
		Adjust	--			278	
		Replace	--			278, 282	
1111	Pitch, Roll, Yaw, and Thrust Viscous Dampers	Inspect	--				
		Test		--		T64, T100, 270	
		Adjust		--		T64, T100, 270	
		Replace	--			278, 282	
1112	Damper Arms and Connecting Links	Repair		--		T64, 242, 270, 274	
		Inspect	--				
		Replace	--			278, 282	
		Repair		--		278	

MAINTENANCE ALLOCATION CHART							
Section II							
NOMENCLATURE OF END ITEMS							
(1) Group Number	(2) Component/Assembly	(3) Maintenance Function	(4) Maintenance Category			(5) Tools and Equipment	(6) Remarks
			AVUM	AVIM	DEPOT		
1113	Magnetic Brakes	Inspect	--				
		Test		--		242, 278	
		Adjust		--		278	
		Replace	--			278, 282	
		Repair		--		278	
		Overhaul			--		
1114	CCDA, Thrust and Pitch	Inspect	--				
		Test		--		242, 277	
		Adjust		--		T51	
		Replace	--			235, 236, 242, 268	
		Repair		--		278	
		Overhaul			--	278, 282	
		Repair		--		242, 268, 269	
1115	Spring Assemblies, Pitch, Roll and Yaw (Artificial Feel)	Inspect	--				
		Test		--		208, 278	
		Adjust		--		278	
		Replace	--			278, 282	
		Repair		--		221, 242, 278	
1116	Yaw, Pitch, and Roll Position Transducer	Inspect	--				
		Test	--			T128	
		Adjust	--			T128, T133, 277, 278	
		Replace	--			T128, T133, 278, 282	
		Repair		--		242, 278	

MAINTENANCE ALLOCATION CHART							
Section II							
NOMENCLATURE OF END ITEMS							
(1) Group Number	(2) Component/Assembly	(3) Maintenance Function	(4) Maintenance Category			(5) Tools and Equipment	(6) Remarks
			AVUM	AVIM	DEPOT		
1117	Bellcranks, Intermediate	Inspect	--				
		Replace	--			245, 278, 282	
		Repair	--			278, 282	
1118	Connecting Links Between Intermediate and First Stage Mixing	Inspect	--			274	
		Adjust	--				
		Replace	--			278, 282	
		Repair	--			278, 282	
1119	Bellcranks, First Stage			--		T169, 237	
		Inspect	--				
1120	Bellcranks, Second Stage	Adjust	--			T44, T135, 278, 282	
		Replace	--			T44, T45, T46, T135, 278, 282	
		Repair	--			T44, 278	
1121	Bellcranks, Between Second Stage and Forward Servocylinders	Inspect	--				
		Adjust	--			278, T44, T135, 282	
		Replace	--			T44, T45, T46, T135, 278, 282	
		Repair	--			278, 282	
1121	Bellcranks, Between Second Stage and Forward Servocylinders	Inspect	--				
		Adjust	--			T44, T135, 278, 282	
		Replace	--			T44, T135, 278, 282	
		Repair	--			278	

MAINTENANCE ALLOCATION CHART							
Section II							
NOMENCLATURE OF END ITEMS							
(1) Group Number	(2) Component/Assembly	(3) Maintenance Function	(4) Maintenance Category			(5) Tools and Equipment	(6) Remarks
			AVUM	AVIM	DEPOT		
1122	Connecting Links, Between Second Stage and Forward Servocylinders	Inspect	--			274	
		Adjust	--			278	
		Replace	--			278, 282	
		Repair	--			282	
1123	Connecting Links Between First and Second Stage Mixing	Inspect	--			274	
		Adjust	--			278	
		Replace	--			278, 282	
		Repair	--			282	
1124	Bellcrank, Transfer Pitch, Thrust, Roll, and Yaw	Inspect	--				
		Replace	--			T128, 278, 282	
		Repair	--			278	
112401	Bellcrank Support	Replace	--			278, 282	
1125	Yoke Assemblies, Longitudinal Cyclic Trim	Inspect	--			274, 278	
		Replace	--			231, 278, 282	
		Repair	--	--		221, 236, 242, 274, 278	
1126	Tunnel Control Arms and Idlers	Inspect	--				
		Replace	--			T44, T135, 278, 282	
		Repair	--			278	
1127	Connecting Links Between Second Stage and Aft Servocylinders	Inspect	--			274	
		Adjust	--			T44, T135, 278, 282	
		Replace	--			T44, T135, 278, 282	
		Repair	--			278, 282	

MAINTENANCE ALLOCATION CHART							
Section II							
NOMENCLATURE OF END ITEMS							
(1) Group Number	(2) Component/Assembly	(3) Maintenance Function	(4) Maintenance Category			(5) Tools and Equipment	(6) Remarks
			AVUM	AVIM	DEPOT		
1128	Bellcranks, Aft Fuselage and Pylon	Inspect	--				
		Adjust	--			T44, T135, 278, 282	
		Replace	--			T44, T135, 278, 282	
		Repair	--			278, 282	
1129	Stick Position Indicator	Inspect	--				
		Adjust	--			278	
		Replace	--			282, 278	
		Repair	--			278	
1130	Longitudinal Cyclic Trim Link	Inspect	--				
		Adjust	--			278	
		Replace	--			278, 282	
		Repair	--	--		221, 242, 278	
1131	Thrust Control	Inspect	--			278	
		Adjust	--			278, 282	
		Replace	--			278, 282	
		Repair	--	--		221, 242, 266, 277, 278	
1132	Pitch and Roll Control Stick	Inspect	--				
		Replace	--			278, 282	
1133	AFCS Panel	Inspect	--				
		Test	--			T51	
			--	--		T52, 236, 268	
		Replace	--			269, 278	
		Repair	--	--		266, 269	
12	UTILITY SYSTEMS						
1201	Windshield Wiper Blades	Inspect	--				
		Replace	--			278	

MAINTENANCE ALLOCATION CHART							
Section II							
NOMENCLATURE OF END ITEMS							
(1) Group Number	(2) Component/Assembly	(3) Maintenance Function	(4) Maintenance Category			(5) Tools and Equipment	(6) Remarks
			AVUM	AVIM	DEPOT		
1202	Windshield Wiper Arms	Inspect	--				
		Adjust	--			282, 294	
		Replace	--			278	
1203	Windshield Wiper Motor	Inspect	--				
		Test		--		236, 242, 277	
		Replace	--			278	
1204	Windshield Wiper Flexible Shaft	Inspect	--				
		Replace	--			278	
		Repair		--		277	
1205	Windshield Wiper Resistor and Switch	Inspect	--				
		Replace	--			277	
1206	Windshield Wiper Converter	Inspect	--				
		Adjust	--				
		Replace	--			278	
1207	Windshield Anti-Icing Element	Inspect	--				
		Test	--			277	
1208	Windshield Anti-Icing Relays	Inspect	--				
		Replace	--			277	
1209	Windshield Anti-Icing Controller	Inspect	--				
		Replace	--			277	
1210	Fire Extinguisher Container and Valve	Inspect	--			274, 282	
		Replace	--			278, 295	
		Overhaul			--		
1211	Fire Extinguisher Lines, and Check Valves	Inspect	--				
		Replace	--			278, 282	
1212	Fire Extinguisher Explosive Cartridge (Squib)	Inspect	--				
		Test	--				
		Replace	--			278, 282	

MAINTENANCE ALLOCATION CHART							
Section II							
NOMENCLATURE OF END ITEMS							
(1) Group Number	(2) Component/Assembly	(3) Maintenance Function	(4) Maintenance Category			(5) Tools and Equipment	(6) Remarks
			AVUM	AVIM	DEPOT		
1213	Fire Detection Control Unit	Inspect	--				
		Replace	--			277	
1214	Fire Detection Relay Panels, Sensing Elements, Wiring and Terminals	Inspect	--			274	
		Test	--			277, 282	
		Replace	--			272, 277, 282	
1215	Emergency Fire Control Handle	Inspect	--				
		Replace	--			277	
		Repair	--				
121501	Emergency Fire Handle Covers	Inspect	--				
		Replace	--			278	
1216	Fire Extinguisher System Switch and Actuator Adapter	Test	--				
		Replace	--			277	
1217	Fire Extinguisher Agent Switch	Inspect	--				
		Replace	--			277	
1218	Fire Extinguisher System Discharge Nozzle	Inspect	--				
		Replace	--			278	
13	ENVIRONMENTAL CONTROL						
1301	Heater Unit	Inspect	--			274, 282	
		Test		--		T62, T63, 242, 278	
		Replace	--			278, 282	
		Repair		--		275, 278	
		Overhaul			--		
1302	Heater Fan	Inspect	--			274	
		Test		--		242, 277	
		Replace	--			282	
		Repair		--		242, 277, 278	

MAINTENANCE ALLOCATION CHART							
Section II							
NOMENCLATURE OF END ITEMS							
(1) Group Number	(2) Component/Assembly	(3) Maintenance Function	(4) Maintenance Category			(5) Tools and Equipment	(6) Remarks
			AVUM	AVIM	DEPOT		
1303	Heater Ducts	Inspect	--				
		Replace	--			278	
		Repair	--			275	
130301	Nose Enclosure Air Diffuser	Inspect	--				
		Replace	--			278	
130302	Defroster Nozzle	Inspect	--				
		Replace	--			278	
130303	Defrost Control	Inspect	--				
		Replace	--			278	
130304	Cockpit Air Controls	Inspect	--				
		Replace	--			278	
130305	Cabin Air Control	Inspect	--				
		Replace	--			278	
1304	Defrost Valve	Inspect					
		Replace				278	
1305	Cabin Temperature Selector Switch	Inspect	--				
		Replace	--			277	
1306	Heater Air Pressure Switch	Inspect	--				
		Replace	--			278	
1307	Cabin Temperature Controller	Inspect	--				
		Replace	--			278	
1308	Cabin Thermostat	Inspect	--				
		Replace	--			278	
1309	Heater Fuel Control	Inspect	--				
		Replace	--			278	
		Overhaul			--		
1310	Heater Fuel Solenoid Valve	Inspect	--				
		Replace	--			278	
1311	Heater Ignition Unit	Inspect	--				
		Replace	--			278	
		Overhaul			--		

MAINTENANCE ALLOCATION CHART								
Section II								
NOMENCLATURE OF END ITEMS								
(1) Group Number	(2) Component/Assembly	(3) Maintenance Function	(4) Maintenance Category			(5) Tools and Equipment	(6) Remarks	
			AVUM	AVIM	DEPOT			
131101	Ignition Unit Vibrator	Inspect	--					
		Replace	--			278		
1312	Shielded Lead Assembly	Inspect	--					
		Replace	--			278		
1313	Heater Thermostat Switches	Inspect	--					
		Replace	--			278		
1314	Heater Control Box Relays	Inspect	--					
		Replace	--			277, 282		
1315	Heater Wiring, Hoses, Lines and Fittings	Inspect	--					
		Replace	--			278		
		Repair	--			278		
14	HOISTS AND WINCHES							
1401	Winch, Rescue and Cargo Handling	Inspect	--					
		Test	--					
		Adjust	--					
					--		278	
		Replace	--				278	
		Repair	--					
140101	Clutch Chains and Roller Chains			--		278		
		Inspect	--					
		Replace	--			278		
1402	Hook and Cable Assembly	Inspect	--			274		
		Replace	--			278		
1403	Cable Cutter Assembly			--		242, 278		
		Inspect	--					
		Service	--			278		
1404	Winch Cable	Replace	--			278		
		Inspect	--					
		Replace	--			278		

MAINTENANCE ALLOCATION CHART							
Section II							
NOMENCLATURE OF END ITEMS							
(1) Group Number	(2) Component/Assembly	(3) Maintenance Function	(4) Maintenance Category			(5) Tools and Equipment	(6) Remarks
			AVUM	AVIM	DEPOT		
1405	Tackle Block/Cable Block	Inspect	--				
		Replace	--			278	
1406	Stowage Container	Inspect	--				
		Replace	--			278	
1407	Hoist Operators Harness	Inspect	--				
15	AUXILIARY POWERPLANT (T-62T-2B)						
1501	APU Assembly	Inspect	--				
		Service	--				
		Test	--			14	
		Replace	--			T57, 251, 260, 278, 282	
NOTE							
Refer to the Maintenance Allocation Chart in TM 55-2835-205-23 for other maintenance functions for the gas turbine auxiliary power unit (APU).							
1502	APU Exhaust Duct	Inspect	--				
		Replace	--			T57, 251, 278, 282	
1503	APU Aft Mounts and Link	Inspect	--			274	
		Replace	--			T57, 278	
		Repair	--			251, 275	
16	MISSION EQUIPMENT						
1601	Center Cargo Hook Assembly	Inspect	--			274	
		Service	--				
		Test	--			278, 282	
					--	231, 235, 238, 270, 286	
		Adjust	--			270	
					--	270	
		Replace	--			278	
		Repair	--			278	
				--	278		
	Install	--			278		

MAINTENANCE ALLOCATION CHART							
Section II							
NOMENCLATURE OF END ITEMS							
(1) Group Number	(2) Component/Assembly	(3) Maintenance Function	(4) Maintenance Category			(5) Tools and Equipment	(6) Remarks
			AVUM	AVIM	DEPOT		
160101	Emergency Cable, Manual	Inspect	--				
		Adjust	--			270	
		Replace	--			278	
160102	Spring Emergency Manual Release	Inspect	--				
		Replace	--			278	
160103	Handle, Emergency Manual Release	Inspect	--				
		Replace	--			278	
16010301	Manual Release Mechanism	Inspect	--			278	
16010302	Manual Release Cable	Replace	--				
16010303	Manual Release Cable, Center Hook	Remove	--			278	
		Install	--			278, 305	
		Adjust	--			278	
160104	Cylinder Assembly	Service	--				
		Inspect	--				
		Replace		--			
		Overhaul			--		
1602	Center Cargo Hook Support Beam and Bearings	Inspect	--				
		Replace	--			278, 282	
		Repair	--			278	
160201	Center Cargo Hook Support Beam Bushings and Bearings	Inspect	--			306, 307	
		Replace	--			278, 308	

MAINTENANCE ALLOCATION CHART							
Section II							
NOMENCLATURE OF END ITEMS							
(1) Group Number	(2) Component/Assembly	(3) Maintenance Function	(4) Maintenance Category			(5) Tools and Equipment	(6) Remarks
			AVUM	AVIM	DEPOT		
1603	Forward and Aft Cargo Hook Assembly	Inspect	--	--		274, 278	
		Service	--				
		Test	--	--		202, 235, 242, 277, 286, 291	
		Adjust		--		236, 242, 277, 286, 291	
		Replace	--			267, 278	
		Repair	--	--		236, 239, 242, 266, 278	
160301	Solenoid Cover and Wire Harness	Inspect	--			266	
		Replace	--			267, 277	
160302	Load Beam and Trunion Bumpers	Inspect	--				
		Replace	--			278	
160303	Inspection Windows	Inspect	--				
		Replace	--			278	
160304	Hook Keeper	Inspect	--				
		Replace	--			278	
160305	Threaded Inserts	Inspect		--			
		Replace		--		237	
160306	Manual Release Cable	Inspect	--				
		Replace	--			278, 282	
		Adjust	--			278, 282	
160307	Manual Release Lever	Inspect	--				
		Replace	--			278	
160308	Manual Release Bellcrank	Inspect	--				
		Replace	--			278	
160309	Manual Release Mount	Inspect	--				
		Replace	--			278	

MAINTENANCE ALLOCATION CHART							
Section II							
NOMENCLATURE OF END ITEMS							
(1) Group Number	(2) Component/Assembly	(3) Maintenance Function	(4) Maintenance Category			(5) Tools and Equipment	(6) Remarks
			AVUM	AVIM	DEPOT		
1604	Paratroop Anchor Lines Assembly	Inspect	--				
		Replace	--			278, 282	
		Repair	--			278	
1605	Flare Dispenser System	Inspect	--				
		Replace	--			277	
		Repair		--		277	16
		Test	--		--	248, 277	16
160501	Status Panel	Inspect	--				
		Replace	--			277	
160502	Timer	Inspect	--				
		Replace	--			277	
160503	Relay	Inspect	--				
		Replace	--			277	
1606	Litters, Poles, and Straps	Inspect	--				
		Replace	--				
		Adjust	--				
160601	Litter Support Bracket	Inspect	--				
		Replace	--			278	
160602	Pilot and Copilot Seat Armor	Inspect	--				
		Replace	--			278	
1607	Countermeasures Dispenser System	Inspect	--				
		Replace	--			277	
		Repair			--	277	
		Test	--			315	
160701	DCDU	Inspect	--				
		Replace	--			277	
160702	Programmer	Inspect	--				
		Replace	--			277	
160703	Sequencer	Inspect	--				
		Replace	--			277	

MAINTENANCE ALLOCATION CHART

Section II

NOMENCLATURE OF END ITEMS

(1) Group Number	(2) Component/Assembly	(3) Maintenance Function	(4) Maintenance Category			(5) Tools and Equipment	(6) Remarks
			AVUM	AVIM	DEPOT		
160704	Miscellaneous Lighting Panel	Inspect	--			278	
		Replace	--				
160705	Junction Box	Inspect	--			278	
		Replace	--				
160706	Dispenser Assembly	Inspect	--			278	
		Replace	--				
160707	Safety Switch	Inspect	--			278	
		Replace	--				
17	EMERGENCY EQUIPMENT						
1701	First Aid Kit	Inspect	--			278	
		Replace	--				
1702	Emergency Escape Axe	Inspect	--			278	
		Replace	--				
1703	Emergency Exit Lighting	Inspect	--			278	
		Test	--				
		Replace	--				
		Repair	--				
170301	Batteries	Service	--			277	
170302	Panel and Pan	Inspect	--			278	
		Replace	--				
1704	Inertia Switch	Inspect	--			277	
		Replace	--				
1705	Portable Fire Extinguishers and Brackets	Inspect	--			278	
		Replace	--				

NOTE

AVUM level replacement is limited to removal and reinstallation of the same pitch varying housing.

SECTION III

TOOL AND TEST EQUIPMENT REQUIREMENTS				
NOMENCLATURE OF END ITEMS CH-47D HELICOPTER				
TOOL OR TEST EQUIPMENT REFERENCE CODE	MAINT. CAT.	NOMENCLATURE	NATIONAL/NATO STOCK NUMBER	TOOL NUMBER
T1	AVUM	Container, Aft Vertical Shaft	8145-01-128-1843	145G0031-1
T2	AVUM	Torque Applicator	5961-00-111-4795	145GS279-1
T3	AVUM	Sling Assembly, Engine Transmissions	1730-00-756-9186	114E5903-1
T4	AVUM	Hoisting Unit	1730-00-760-3367	114E5128-3
T5	AVUM	Socket, Horizontal Hinge Pin Locknut (End Cap)		145G0035-1
T6	AVUM	Pusher, Rotor Head	5120-00-979-7582	114E5803-1
T7		Deleted		
T8	AVIM	Puller, Outboard Seal	5120-00-864-0510	114E5809-1
T9	AVUM	Puller, Bearing, Rotor Head	5120-00-944-2525	114E5813-6
T10	AVUM	Puller, Bearing, and Seal, Rotor Hub	5120-00-917-1020	114E5814-7
T11	AVIM	Drift, Outboard Seal Installation		234G0096-1
T12	AVUM	Guide Set, Roller Bearing Seals, Rotor Hub	5120-00-867-5501	114E5824-4
T13	AVUM	Adapter, Rotor Head Assembly	1730-00-863-5785	114E5840-1
T14	AVIM	Sling, Rotor Head Controls	1730-00-179-1326	114E5852-16
T15	AVUM	Adapter, Forward Transmission	1560-00-863-5886	145E5871-1
T16	AVUM	Adapter, Powerplant	4920-00-917-1880	114E5872-35
T17	AVUM	Adapter, Aft Transmission	4920-01-128-6320	145E5874-1
T18	AVUM	Adapter, Vertical Shaft Assembly	4920-01-130-9688	114E5878-60
T19	AVUM	Adapter, Rotary-Wing Set	4920-01-115-6999	114G0020-1
T20	AVUM	Adapter, Combining Transmission	1730-00-863-5789	114E5888-1
T21	AVUM	Heater Exhaust Cover	1730-00-785-2055	114G1025-1
T22	AVUM	Pin Set, Blade Folding Pitch Lock	1730-00-867-1253	114E5897-11
T23	AVUM	Torque Pack	4920-01-059-2853	PD1220
T24	AVUM	Ring Assembly, Forward Transmission and Aft Vertical Shaft	1730-00-010-7462	114E5909-8
T25	AVUM	Tool Set (Easy-Out), Replacement, Tiedown Receiver	4920-01-123-2576	114G0039-1
T26		Deleted		
T27		Deleted		
T28	AVUM	Reaction Adapter	5120-01-130-1462	145G0037-1
T29	AVUM	Socket, Hub Nut		145G0141-1

TOOL AND TEST EQUIPMENT REQUIREMENTS				
NOMENCLATURE OF END ITEMS CH-47D HELICOPTER				
TOOL OR TEST EQUIPMENT REFERENCE CODE	MAINT. CAT.	NOMENCLATURE	NATIONAL/NATO STOCK NUMBER	TOOL NUMBER
T30	AVUM	Lifting Device, Rotor Head Assembly	1730-00-945-8251	114E5899-19
T31	AWM	Safety Blocks	1730-00-034-3874	114E5900-17
T32	AVUM	Hoisting Eye, Forward Transmission and Aft Shaft		145E5902-1
T33	AVUM	Guide, Lip Seal, Vertical Hinge Pin	5120-01-130-1464	145G1471-1
T34	AVUM	Sling Assembly, Combining Transmission		145E5903-1
T35	AVUM	Sling, Handling, Rotary Wing Assembly	4920-01-115-7001	145E5911-101
T36	AVUM	Container, Combining Transmission	8145-01-128-4725	145G0024-1
T37	AVUM	Container, Aft Transmission	8145-01-128-1857	145G0023-1
T38	AVUM	Container, Engine Transmission	8115-00-420-7824	114E5918-8
T39	AVUM	Rigging Set, Controls		145E5941-11
T40	AVUM	Line, Tiedown	1730-00-075-1055	114E5060-1
T41	AVUM	Rate Table, Aircraft Displacement (AN/ASM-120 Equiv)	4920-00-923-2391	114E5988-1
T42	AVUM	Dummy Link Assembly (Dash Actuator), P/O 145E5941-11 (T39)		145G5002-1
T43		Deleted		
T44	AVUM	Rigging Pin A, First Stage Mixing Linkage, P/O 145E5941-11 (T39)	1730-01-142-2851	145G5004-1
T45	AVUM	Rigging Pin B, First Stage Mixing Linkage, P/O 145E5941-11 (T39)		145G5004-2
T46	AVUM	Rigging Pin C, First Stage Mixing Linkage, P/O 145E5941-11 (T39)		145G5004-3
T47	AVUM	Reaction Adapter Set, Vertical Hinge Pin	5120-00-625-3885	PD1434
T48	AVUM	Torque Wrench	5120-00-169-2986	PD1201
T49	AVUM	Sling, Aft Transmission, P/O 114E5124-1 (T85)	1730-00-073-3294	114E5119-2
T50	AVUM	Securing Device, Aft Vertical Shaft		145E5996-1
T51	AVUM	AFCS Line Test Set	4920-01-121-0603	145G0009-1
T52	AVIM	AFCS Bench Test Set	4920-01-121-0602	145G0008-1
T53	AVIM	ILCA Bench Test Set	4920-01-121-0604	145GS278-1
T54	AVIM	Sling, Aft Pylon	1730-00-844-2055	114E5855-2
T55	AVIM	Skid, Aft Pylon	1740-00-883-1658	114E5856-22
T55.1	AVIM	Skid Outrigger, Aft		
T56	AVIM	Test Manifold	4920-01-128-6317	145G0054-1
T57		Deleted		
T58	AVUM	Rotary-Wing Head Covers, Forward and Aft	1730-00-839-7063	114G1023-25

TOOL AND TEST EQUIPMENT REQUIREMENTS				
NOMENCLATURE OF END ITEMS CH-47D HELICOPTER				
TOOL OR TEST EQUIPMENT REFERENCE CODE	MAINT. CAT.	NOMENCLATURE	NATIONAL/NATO STOCK NUMBER	TOOL NUMBER
T59	AVUM	Heater Inlet Cover	1730-00-907-7676	114G1024-1
T60	AVUM	Hydraulic Cooler Exhaust Cover	1730-01-142-2851	145G0004-1
T61	AVUM	APU Exhaust Cover	1730-01-139-4776	145G0005-1
T62		Deleted		
T63		Deleted		
T64	AVIM	Spanner Wrench, Viscous Damper	5120-00-097-8425	114GS225-1
T65	AVUM	Accessory Kit, Track and Balance (VIBREX)	4920-01-115-7002	114G0019-1
T66	AVUM	Oil Cooler Inlet Cover	1730-01-145-1182	145G0001-1
T67	AVUM	Oil Cooler Exhaust Cover	1730-01-136-9764	145G0002-5
T68	AVUM	Oil Cooler Exhaust Cover	1730-01-140-2842	145G0002-6
T69	AVUM	Replacement Fixture, Nickel Erosion Cap	4920-01-115-7000	114G0021-1
T70	AVUM	Protective Cap, Vertical Pin	1560-01-123-2575	114G0017-1
T71	AVIM	Sling Assembly, Aircraft Hoisting	1730-00-071-1690	114G1013-1
T72	AVIM	Rigging Tool, Lead-Lag Damper	5180-00-168-2294	114G1014-17
T73	AVUM	Shipping Container, Rotary-Wing Head	8145-01-128-1739	114G1017-70
T74	AVUM	Shipping Container, Forward Transmission	8145-01-128-1856	145G0022-1
T75	AVUM	Steering Bar, Aft Landing Gear	1730-01-299-8688	CHSE001-2
T76	AVUM	Air Inlet Cover	1730-01-139-4775	145G0003-1
T77	AVUM	Attachment Fittings, Transport Tiedown	1730-00-168-6153	114G1049-14
T78	AVUM	Assembly Fixture, Pitch Link	4920-00-879-3045	114G1102-11
T79	AVUM	Puller, Vertical Pin, Rotor Head	5180-00-103-0001	114G1137-10
T80	AVUM	Engine Outlet Cover	1730-00-191-9373	114G1323-1
T81	AVUM	Pitot Tube Cover	1730-00-435-7802	114E5040-33
T82		Deleted		
T83		Deleted		
T84	AVUM	Adapter, Handling	1740-00-462-8761	114G1354-1
T85	AVUM	Hoist, Aft Transmission	1730-00-960-4004	114E5124-1
T86	AVUM	Container, Shipping and Storage, Rotor Blade	8145-01-102-3048	114G0015-65
T87	AVUM	Pusher, Horizontal Hinge Pin	4920-00-842-5899	114G1185-1
T88	AVIM	Heater Probe	4920-01-152-7450	BH22231
T89	AVUM	Bracket Locating Fixture, Proximity Switch	4920-01-147-6321	145G0059-1
T90	AVUM	Test Set, Hydraulic System	4920-00-174-7823	114G1038-86
T91		Deleted		
T92		Deleted		

TOOL AND TEST EQUIPMENT REQUIREMENTS				
NOMENCLATURE OF END ITEMS CH-47D HELICOPTER				
TOOL OR TEST EQUIPMENT REFERENCE CODE	MAINT. CAT.	NOMENCLATURE	NATIONAL/NATO STOCK NUMBER	TOOL NUMBER
T93	AVUM	Adapter, Socket, Forward Transmission Mounting Bolts		145G0140-1
T94	AVUM	Drift, Bearing, Aft Landing Gear	5120-00-891-1369	114G1200-1
T95		Deleted		
T96		Deleted		
T97	AVUM	Drift, Bearing, Aft Landing Gear	5120-00-993-5117	114G1203-1
T98	AVUM	Puller/Pusher, Damper Bracket Bushing	5120-01-123-2682	114G0018-6
T99		Deleted		
T100	AVIM	Test Set, Viscous Damper	4920-00-484-3958	114G1208-1
T101	AVUM	Jetcal Analyzer, Temperature Tester	4920-00-372-4593	BH112JB-53
T102	AVUM	Puller Assembly, Bearing, Pitch Housing	5120-00-879-3710	114G1236-1
T103	AVUM	Protective Cover, Cockpit	1730-01-136-5619	145G0006-1
T104	AVUM	Test Harness, Engine PTIT Indicator System and Emergency Power Panel	4920-01-152-7452	BH22101
T105	AVUM	Swaging Tool, Pitch Link	5120-00-247-0216	114G1263-1
T106	AVIM	Setting Fixture, Blade Lag Shock Absorber	4920-00-369-9545	114G1306-1
T107	AVUM	Container, Blade Lag Shock Absorber	8115-00-400-7730	114G1322-1
T108	AVIM	Staking Die, Shock Absorber Assembly	5120-00-400-7708	114G1334-1
T109	AVIM	Staking Tool, Aft Engine Mount	5180-00-176-3726	114G1359-1
T110	AVIM	Fixture, Locating, Sliding Beating, Rotor Head Controls	4920-00-522-3784	114G1373-1
T111	AVUM	Tempcal Probe, Temperature Transmitter Chip Detector	4920-01-151-9218	BH22223
T112	AVUM	Test Harness, Self-Tuning Dynamic Absorber	4920-00-134-4534	114G1408-1
T113	AVIM	Locating and Drill Fixture, Sync Shaft Brackets	4920-00-176-4260	114G1410-1
T114	AVIM	Locating and Drill Fixture, Sync Shaft Brackets	4920-00-157-1427	114G1411-1
T115	AVUM	Test Harness Set, N1 Actuator System	4920-00-150-5955	145G1414-1
T116	AVUM	Repair Fixture, Rotor Blade Trailing Edge	4920-01-115-6998	145G1004-1
T117	AVIM	Test Block, Flight Control Power Control Module Accumulator	4920-01-128-6315	145G0055-1
T118	AVIM	Test Block, PTU Motor Shaft Seal	4920-01-128-6316	145G0056-1
T119	AVUM	Yaw Travel Quadrant, p/o 145E5941-11 (T39)		145G5310-1
T120	AVUM	Roll Travel Quadrant, p/o 145E5941-11 (T39)		145G5310-5
T121	AVUM	Pitch Travel Quadrant, p/o 145E5941-11 (T39)		145G5310-8

TOOL AND TEST EQUIPMENT REQUIREMENTS				
NOMENCLATURE OF END ITEMS CH-47D HELICOPTER				
TOOL OR TEST EQUIPMENT REFERENCE CODE	MAINT. CAT.	NOMENCLATURE	NATIONAL/NATO STOCK NUMBER	TOOL NUMBER
T122	AVUM	Thrust Rig Pin, p/o 145E5941-11 (T39)		114E5941-4
T123	AVUM	Cockpit Rig Fixture, p/o 145E5941-11 (T39)		114E5941-21
T124	AVUM	Pointer Assembly, p/o 145E5941-11 (T39)		114E5941-26
T125	AVUM	Control Stick Yoke, p/o 145E5941-11 (T39)		114E5941-57
T126	AVUM	Pedal Pointer, p/o 145E5941-11 (T39)		114E5941-73
T127	AVUM	Pedal Rig Pin, p/o 145E5941-11 (T39)		114E5941-74
T128	AVUM	Transfer Bellcrank Rig Pin, p/o 145E5941-11 (T39)		114E5941-108
T129		Deleted		
T130	AVUM	Dash Actuator Rigging Tool, p/o 145E5941-11 (T39)		145G5306-1
T131	AVUM	Engine Inlet Cover (Helicopter with Screens)	5961-00-847-5244	219G1001-1
T132	AVUM	Engine Inlet Cover (Helicopter without Screens)	1730-00-990-9838	114G1206-1
T133	AVUM	Pallet Rig Pin, p/o 114E5941-11 (T39)		114E5941-4
T134	AVUM	Sling, Engine	1730-01-007-6990	LTCT14700
T135	AVUM	Second Stage Rig Pin, p/o 114E5941-11 (T39)	1730-00-760-3375	114E5985-9
T136	AVIM	Repair Kit, Hydraulic Tube, p/o D12102C-15-H10 (T181)	5180-01-115-7008	D12102C01-01
T137	AVIM	Repair Kit, Hydraulic Tube, p/o D12102C-15-H10 (T181)	5180-01-026-0255	D12102C06-06
T138	AVIM	Repair Kit, Hydraulic Tube, p/o D12102C-15-H10 (T181)	5180-01-026-0254	D12102C09-04
T139	AVIM	Power Supply, Hydraulic Tube Repair, p/o D12102C-15H10 (T172)	4320-01-098-6713	D12025-001
T140	AVUM	Tool Kit, Rosan Adapter	5180-00-283-6993	KM13
T141	AVUM	Tool Kit, Rosan Adapter	5180-00-283-6992	KM14
T141.1	AVUM	Tool Kit, Rosan Adapter		KM15
T142	AVUM	Tool Kit, Rosan Adapter	5180-00-283-6999	KM18
T143	AVUM	Tool Kit, Rosan Adapter	5180-00-283-6989	KM19
T143.1	AVUM	Tool Kit, Rosan Adapter		KM28
T143.2	AVUM	Tool Kit, Rosan Adapter		KM29
T144	AVUM	Tool Kit, Rosan Adapter	5180-00-075-0766	KM30
T145	AVUM	Tool Kit, Rosan Adapter	5180-00-077-1578	KM31
T145.1	AVUM	Tool Kit, Rosan Adapter		KM32
T145.2	AVUM	Tool Kit, Rosan Adapter		KM33

TOOL AND TEST EQUIPMENT REQUIREMENTS				
NOMENCLATURE OF END ITEMS CH-47D HELICOPTER				
TOOL OR TEST EQUIPMENT REFERENCE CODE	MAINT. CAT.	NOMENCLATURE	NATIONAL/NATO STOCK NUMBER	TOOL NUMBER
T145.3	AVUM	Tool Kit, Rosan Adapter		KM35
T145.4	AVUM	Tool Kit, Rosan Adapter		KM36
T146	AVIM	Bender Set, Hydraulic Tube		130-8500800
T147	AVUM	Drive Tool, Clinch Nut, Aft Trans	5120-00-455-2734	REA048D
T148	AVUM	Drive Tool, Clinch Nut, Aft Trans	5120-01-130-1458	REA064D
T149	AVUM	Removal Tool, Rosan Adapter		RF12LPDE
T150	AVUM	Removal Tool, Rosan Adapters	5120-01-047-9302	RF16LPDE
T150.1	AVUM	Drive Tool and Combination Wrench, Rosan Adapters		RF9806DW
T150.2	AVUM	Drive Tool and Combination Wrench, Rosan Adapters		RF9808DW
T150.3	AVUM	Drive Tool and Combination Wrench, Rosan Adapters		RF9810DW
T151	AVUM	Drive Tool and Combination Wrench, Rosan Adapters	5120-01-130-1459	RF9812DW
T152	AVUM	Drive Tool and Combination Wrench, Rosan Adapters	5120-01-130-1460	RF9816DW
T152.1	AVUM	Lockring Removal Tool, Rosan Adapters		RF9806LPD
T152.2	AVUM	Lockring Removal Tool, Rosan Adapters		RF9808LPD
T152.3	AVUM	Lockring Removal Tool, Rosan Adapters		RF9810LPD
T152.4	AVUM	Lockring Removal Tool, Rosan Adapters		RF9816LPW
T152.5	AVUM	Packing Tool, Rosan Adapters		ORT437
T152.6	AVUM	Packing Tool, Rosan Adapters		ORT562
T152.7	AVUM	Packing Tool, Rosan Adapters		ORT687
T152.8	AVUM	Packing Tool, Rosan Adapters		ORT1125
T153	AVIM	Insertion Tool, Cargo Hook	5120-00-964-3494	TD428L
T154	AVIM	Insertion Tool, Cargo Hook	5120-00-134-7498	TD1032L
T155	AVIM	Insertion Tool, Cargo Hook		TKNC06
T156		Deleted		
T157	AVIM	Spanner Wrench-Spring Return Assembly Cargo Hook		34-151
T158	AVUM	Test Set, Fuel Vent Check		2TE414P0200-8
T159	AVUM	Torque Reactor, Fwd Transmission Mounting Bolts	5120-01-130-1463	145G0051-1
T160	AVUM	Torque Plate, Aft Transmission	1730-01-130-9689	145G0034-1
T161	AVUM	Tee Handle, P/O PD1220 (T23)	5120-01-140-3480	PD1612
T162	AVIM	Test Fixture, Accumulator, APU Start Module	4920-01-128-6318	1323TF100-1

TOOL AND TEST EQUIPMENT REQUIREMENTS				
NOMENCLATURE OF END ITEMS CH-47D HELICOPTER				
TOOL OR TEST EQUIPMENT REFERENCE CODE	MAINT. CAT.	NOMENCLATURE	NATIONAL/NATO STOCK NUMBER	TOOL NUMBER
T163	AVUM	Sling, Handling, Aft Transmission (Alternate Use With T3)	1730-00-226-3069	114E5924-1
T164		Deleted		
T165		Tackle Block		114E6058-23
T166		Bomb Hoist	1730-01-161-8623	1353 A5100-1
T167	AVUM	Seal and Window Retainer Installation Tool P/O Kit CS1154	5120-00-366-5065	756460/756461
T168	AVUM	Seal Filler Installation Tool, P/O Kit CS1154	5120-00-075-8307	756470/756476
T169		Roller Staking Kit		114G1425-1
T170	AVUM	Spray Gun		MMM8897
T171		Trim Tab Fixture		145G1019-29
T172		Tool Set, Hydraulic Tube		D12102C-15-H10
T173	AVIM	Seal Installation Tool, Ramp Control Valve (Cage 26437)		T-1FA13043-007
T174	AVIM	Seal Sizing Tool, Ramp Control Valve (Cage 26437)		T-1FA13043-007A
T175	AVIM	Seal Installation Tool, Ramp Control Valve (Cage 26437)		T-1FA1305592
T176	AVIM	Seal Sizing Tool, Ramp Control Valve (Cage 26437)		T-1FA1305593
T177	AVIM	Seal Sizing Tool, Ramp Control Valve (Cage 26437)		T-1FA1305594
T178	AVIM	Thermal Relief Valve Test Fixture, Ramp Control Valve (Cage 26437)		TF-1FA1304375
T179	AVIM	Plug, Thermal Relief Valve Test, Ramp Control Valve (Cage 26437)		TP-1FA1304375
T180		Deleted		
T181		Tube Bending Set, Acro		130-850080
T182		Tool Kit, Combining Transmission Support Fitting Replacement		234SK033-3
T183	AVUM	Fuel Quantity Test Set	6625-01-297-5305	PSD60-1AF
T184	AVUM	Fuel Quantity System Test Cable	5995-01-384-3961	PSDAF-106
T185	AVUM	Engine Water Wash System		LTCT 23980-01
T185.1	AVUM	Juniper Engine Wash System		JMP/SHWR/D/0376/0800/BH
T186	AVIM	Scale, Weighing	6670-01-379-4840	GECC4-00000-1
T186.1	AVUM	Ohmmeter, Low Resistance (Biddle)		Model 247000
T187	AVUM	Digital Multimeter		AN/PSM-45A
T188	AVUM	Elec Torquemeter, Flight Line Test Set		LTCT 29089-01/-03

TOOL AND TEST EQUIPMENT REQUIREMENTS				
NOMENCLATURE OF END ITEMS CH-47D HELICOPTER				
TOOL OR TEST EQUIPMENT REFERENCE CODE	MAINT. CAT.	NOMENCLATURE	NATIONAL/NATO STOCK NUMBER	TOOL NUMBER
T200	AVUM	Air Remover, Lamb		
T200.1	AVUM	Assembly Fixture		ST71188
T201	AVUM	Bag, Shot		
T202	AVUM	Coupling Stowage	5935-00-982-1906	MS3180-16C
T203	AVUM	Container, Lead Lined		2S
T204	AVUM	Container, Rubber Lined		
T205	AVUM	Container, Engine		
T206	AVUM	Counterbore, Craig		850-20
T207	AVIM	Counter, Electronic		AM/USM26
T208	AVIM	Dial, Spring Reversing -25 to +25 Pounds		
T208.1	AVIM	Driver, Seal	5120-00-942-1605	ST70273
T208.2	AVIM	Driver, Seal	2835-00-620-9876	ST90889-01
T209	AVIM	Flowmeter, 0-2 gpm		
T210	AVIM	Flowmeter, 0-5 gpm		
T210.1	AVIM	Gauge Set, Wire		ST60880
T211	AVIM	Graduate, 5cc		
T212	AVIM	Graduate, 10cc		
T213	AVIM	Graduate, 20cc		
T214	AVIM	Graduate, 50cc		
T215	AVIM	Graduate, 100cc		
T216	AVIM	Graduate, 500cc		
T217	AVUM	Graduate, 2000cc		
T218	AVIM	Heat Sink	3439-00-973-2249	
T219	AVUM	Indicator, Combustible Gas		
T220	AVUM	Kit, Mooring	1730-00-338-6374	AN8015-2
T221	AVUM/ AVIM	Kit, Roller Staking	5120-00-311-5446	
T222	AVIM	Kit, Rosan	5180-00-778-3789	
T222.1	AVUM	Lifting Fixture	4920-01-135-5987	ST93929
T223	AVUM	Manometer		
T224	AVIM	Meter, Test Set	6625-00-669-0747	TS-682A/GSM-1
T225	AVUM	Multiplier	5120-00-506-9092	SWE-101
T226	AVUM	Mixer, Power		
T227	AVIM	Pilot, Seal		

TOOL AND TEST EQUIPMENT REQUIREMENTS				
NOMENCLATURE OF END ITEMS CH-47D HELICOPTER				
TOOL OR TEST EQUIPMENT REFERENCE CODE	MAINT. CAT.	NOMENCLATURE	NATIONAL/NATO STOCK NUMBER	TOOL NUMBER
T227.1		Deleted		
T228	AVUM	Pump, Siphon		
T229	AVIM	Reamer, 1.876 to 1.877 Inch		
T229.1		Deleted		
T230	AVUM	Repair Tool, Pneumatic		
T231	AVUM/ AVIM	Scale, 0 to 100 Pounds		
T232	AVUM	Screwdriver, Torque 0-30 Inch-Pounds		
T233	AVIM	Scale, Dial Indicating 0 to 0.5 Inch		
T234	AVUM	Screwdriver, Torque 0-50 Inch-Pounds		
T235	AVIM	Shop Set, Hydraulic	4920-00-165-1454	SC492099CLA9LHYA
T236	AVIM	Shop Set, Electrical and Instrument	4920-00-165-1453	SC492099CLA91ELA
T237	AVIM	Shop Set, Machine	4920-00-405-9279	SC492099CLA91MAA
T238	AVIM	Shop Set, Power Train	4920-00-001-4132	SC492099CLAMTAM
T239	AVIM	Shop Set, Sheet Metal	4920-00-166-5505	SC492099CLA91SMA
T240	AVIM	Shop Set, Turbine Engine	4920-00-224-3684	SC492099CLA91ENT
T241	AVIM	Shop Set, Welding	4920-00-163-5093	SC492099CLA91WEA
T242	AVIM	Shop Set, Tool Crib	4920-00-472-4183	AC492099CLA91TCA
T243	AVUM	Socket, 1-3/16 Inch		
T244	AVUM	Socket, 1-1/2 Inch		
T245	AVUM/ AVIM	Socket, 2-1/8 Inch		
T245.1	AVUM	Support Fixture	4920-00-939-1521	ST91717
T246	AVUM	Strap, Tiedown	1670-00-622-3632	SP-4435-2
T247	AVUM	Support, Guide		SLT600T9
T248	AVIM	Test Set	4940-01-048-9677	
T249	AVIM	Test Set, Resistance	6625-00-5422-1331	AN/GSM-6
T250	AVUM	Tester Squib	4925-00-973-3759	MOD115
T251	AVUM	Deleted		
T252	AVIM	Test Set Dielectric		HYP0T1404
T253	AVUM	Test Set, Synchro	4920-00-556-8108	TTU-33/E
T254	AVUM	Test Set, Tach	4920-00-621-2427	TTU-27/E
T255		Deleted		

TOOL AND TEST EQUIPMENT REQUIREMENTS				
NOMENCLATURE OF END ITEMS CH-47D HELICOPTER				
TOOL OR TEST EQUIPMENT REFERENCE CODE	MAINT. CAT.	NOMENCLATURE	NATIONAL/NATO STOCK NUMBER	TOOL NUMBER
T256	AVUM	Tool, Module Extraction	5120-01-097-5219	CTJ-R06
T257	AVUM	Thermometer Tester, Elect		
T258	AVUM	Trailer, Powerplant		
T259	AVUM	Trailer Trans, 2000 Pounds		
T260	AVUM	Trailer, APU	1740-00-516-7929	100334
T260.1	AVUM	Tool Set, AVUM, Set No. 2	4920-00-569-0476	SC492099CLA92
T261	AVUM	Tool, Guide		SLT600G9
T262	AVUM	Tool, Window		756460
T263	AVUM	Tool, Window		756475
T264	AVUM	Tool, Installation		TMD-428L
T265	AVIM	Tool, Contact Removal/Insertion	5120-00-915-4588	M81969/14-03
T266	AVUM/ AVIM	Tool, Contact Removal/Insertion		M83723-31-20
T267	AVUM/ AVIM	Tool Hand, Self Clinching	5120-00-781-7891	
T268	AVUM/ AVIM	Tool Kit, Electronic Repairer	5180-00-064-5178	SC518091CLR13
T269	AVUM/ AVIM	Tool Kit, Electronic Equipment	5180-00-610-8177	SC518091CLR07
T269.1		Deleted		
T270	AVUM/ AVIM	Tool Kit, Hydraulic Repairer	518Q-00-323-4891	SC518097CLA05HR
T270.1	AVUM/ AVIM	Tool Kit, Aircraft Inspector	5180-00-323-5114	SC518097CLA09
T271	AVUM	Tool Kit, Instrument Repairer	4920-00-323-4913	SC518099CLA05
T272	AVUM/ AVIM	Tool Kit, Powerplant Repairer	5180-00-323-4944	SC518099CLA07
T273	AVUM/ AVIM	Tool Kit, Powertrain Repairer	5180-00-003-5267	SC518099CLA13
T274	AVUM/ AVIM	Tool Kit, Technical Repairer	5180-00-323-5114	SC518099CLA09
T275	AVUM/ AVIM	Tool Kit, Airframe Repairer	5180-00-323-4876	SC518099CLA02

TOOL AND TEST EQUIPMENT REQUIREMENTS				
NOMENCLATURE OF END ITEMS CH-47D HELICOPTER				
TOOL OR TEST EQUIPMENT REFERENCE CODE	MAINT. CAT.	NOMENCLATURE	NATIONAL/NATO STOCK NUMBER	TOOL NUMBER
T276	AVUM	Tool Kit, Battery Service	5180-00-542-5812	SC518091CLR03
T277	AVUM/ AVIM	Tool Kit, Electrical Repairer	5180-00-323-4915	SC518099CLA06
T278	AVUM/ AVIM	Tool Kit, Aircraft Mechanic	5180-00-323-4692	SC518099CLA01HR
T279	AVUM	Tool Set, No. 1 Reciprocating Engine	4920-00-159-8728	SC492099CLA90REC
T280	AVUM	Tool Set, No. 1 Fixed Base	4920-00-504-9258	SC492099CLA90W0S
T281	AVUM	Tool Set, No. 1 Airmobile	4920-00-159-8727	SC492099CLA90
T282	AVUM	Tool Set, No. 2 Airmobile	4920-00-567-0476	SC492099CLA92
T283	AVIM	Voltmeter, Differential		Fluke 803B
T284	AVIM	Voltmeter, Digital		
T285	AVUM	Voltmeter		
T286	AVIM	Weight, 20 Pounds		
T287	AVIM	Weight, 25 Pounds		
T288	AVIM	Weight, 50 Pounds		
T289	AVIM	Weight, 94 Pounds		
T290	AVIM	Weight, 160 Pounds		
T291	AVIM	Weight, 250 Pounds		
T291.1	AVIM	Welding Set, Inert Gas	3431-00-079-0498	
T292	AVUM	Wheel, Buffing, Unstitched		
T293	AVUM	Wheel, Buffing Stitched		
T294	AVUM	Wrench	5120-00-076-4380	XW20509
T295	AVUM	Wrench, Box, 1-1/2 Inch		
T296	AVUM	Wrench, Open-End, 1-3/4 Inch		
T297	AVUM	Wrench, Open-End, 1-7/8 Inch		
T298	AVUM	Wrench, Spline	5120-00-288-9085	
T299	AVUM	Wrench, Open-End, 1 Inch		
T300	AVUM	Wrench, Open-End, 2-1/2 Inch		
T301	AVUM	Crowfoot Attachment, 11/16 Inch		
T302	AVIM	Wrench, Open-End, 1-1/8 Inch		
T303	AVUM	Vacuum Pump		
T304	AVUM	Trip Balance	6670-00-401-7195	

TOOL AND TEST EQUIPMENT REQUIREMENTS				
NOMENCLATURE OF END ITEMS CH-47D HELICOPTER				
TOOL OR TEST EQUIPMENT REFERENCE CODE	MAINT. CAT.	NOMENCLATURE	NATIONAL/NATO STOCK NUMBER	TOOL NUMBER
T305		Wrench, 1/4 Inch Drive Torque	5120-00-542-4489	
T306	AVUM	Telescoping Gauge	5120-00-221-2086	
T307	AVUM	Outside Micrometer Caliper Set		GGG-C-105
T308	AVUM	Blind Hole Puller Set	5120-01-008-7974	
T309	AVUM	Remote Tire Inflator		AS1675
T310	AVIM	Test Adapter		145GS278-20
T311	AVUM	Engine Harness Connector Retention Tool		SK32193-1
T312	AVUM	Engine Harness Connector Retention Tool		SK32193-5
T313	AVUM	Spanner Wrench		145G1150-1
T314	AVUM	On Wing Diagnostic Computer Set		LTCT 29330-02
T315	AVUM	Test Set, Countermeasures Dispenser		341000-7001
T316	AVUM	Mission Loader Verifier (MLV)		187961-0002

SECTION IV

REFERENCE CODE
REMARKS/NOTES

The notes 1 thru 28 indicate a notation or remark on that particular maintenance function (Section II) as follows:

1. Limited to airframe repairman's tool kit and portable handtools
 2. Epoxy
 3. Patching by hand methods only
 4. Tire recap
 5. Vibration check
 6. Refer to TM 55-2840-254-23
 7. Includes filter replacement
 8. Test equipment 13819-2A
 9. Refer to TM 11-1520-240-23
 10. Cable adjustment
 11. Using teststand
 12. Buildup
 13. Replace cyclic trim link
 14. Refer to TM 55-2835-205-23
 15. Not requiring jigs or fixtures
 16. Refer to TM 9-1095-206-13 & P
 17. Water/solvent wash-engine in airframe
 18. Weld repair
 19. Replace inserts, helicoils, and studs
 20. Replace support brackets, plugs, and packings
 21. Inspect for chafing, security of installation, dents, kinks, and cracks
 22. Replace nut plates
 23. Limited to reinstallation of same housing
 24. Replacement of impellers limited to Depot level only
 25. As indicated by instructions in this manual
 26. Limited to the capability (skills, tool, test/support equipment, and facilities) available
 27. Without **74**
 28. With **74**
-

APPENDIX C AIRCRAFT INVENTORY

(See Chapter 1, Task 1-109.)

APPENDIX D EXPENDABLE SUPPLIES AND MATERIALS

(See Chapter 1, Task 1-18)

APPENDIX E
ILLUSTRATED FIELD MANUFACTURED ITEMS LIST

SECTION I

INTRODUCTION

This appendix includes complete instructions for making items authorized to be manufactured or fabricated at aviation unit maintenance.

A part number index in alphanumeric order is provided for cross-referencing the part number of the item to be manufactured to the figure which covers fabrication criteria.

All bulk materials needed for manufacture of an item are listed by part number or specification number in a tabular list on the illustration.

E-1	Engine Vibration Test Adapter
E-2	Pitch Housing Seal Removal Tool
E-3	Ramp Control Valve Spanner
E-4	Rotary-Wing Head Pressure Test Fittings and Hose
E-5	Rotor Blade Phasing Block Tool
E-6	LCT Shaft Rotation Lever
E-7	Drive Arm Bushing Installation Adapter
E-8	Sleeve Bearing Removal Adapter
E-9	Sleeve Bearing Installation Adapter
E-10	Drive Arm Removal/Installation Adapter
E-11	Accumulator Leak Test Reservoir
E-12	Hand Pump Test Hydraulic Fluid Reservoir
E-13	Forward LCT Yoke Bushing Removal Tool
E-14	Aft LCT Yoke Bearing Removal Tool
E-15	Cockpit Control Bearing Installation Tool
E-16	Fuel Cell Support Rig
E-17	Refueling System Test Closure Plates
E-18	Forward and Aft Cargo Hook Wire Rope
E-19	Brake Master Cylinder Test Stand
E-20	Heater Fan Support Plate
E-21	Flight Control Cooling Fan Support Plate
E-22	Hydraulic Cooling Fan Support Plate
E-23	(Deleted)
E-24	Lower Drive Arm Bolt Removal Tool
E-25	Upper Drive Arm Bolt Removal Tool
E-26	Strap 145S4908-2 And -16
E-27	(Deleted)
E-28	(Deleted)
E-29	Aluminum Scraper

- E-30 PTU Spanner Wrench
- E-31 Fill Module Support Plate
- E-32 Servocylinder Inspection Fixture
- E-33 Avionics Cooling Fan Support Plate
- E-34 Extensible Link Test Cable 145GS278-20
- E-35 Landing Gear Disk Brake Spanner
- E-36 AFCS Computer Test Hose 1
- E-37 AFCS Computer Test Hose 2
- E-38 Cockpit Transfer Bellcrank Shaft Puller
- E-39 Fuel Hose Assemblies (Various Part Numbers)
- E-40 Forward and Aft Cargo Hook Mount Bushing Tool
- E-41 Shock Absorber Rod End Bearing Pusher Assembly
- E-42 Torquemeter Zero-Adjust Test Cable
- E-43 Fuel Quantity Indicator Test Cable
- E-44 Rotor Blade Balance Weight Spacer 114R1737-2
- E-45 Forward Transmission Mounting Structure Bushing Puller
- E-46 Engine Screen Latch Eyelet 234P5052-7
- E-47 Engine Screen Latch Clip 234P 5052-4
- E-48 Engine Screen Latch Clip 234P5052-3, -8, and -9
- E-49 Engine Screen Latch Retainer 114P8080-18
- E-50 Tube Assemblies (Various Part Numbers)
- E-51 Three-Prong Seal Insertion Tool
- E-52 Seal Forming Tool
- E-53 Aft Landing Gear Drag Link/Shock Strut Liners 145L2330-2 and -/SK31250
- E-54 Teflon Washer 234R2205-1
- E-55 Fuel Tank Test Plug
- E-56 Inboard Seal Installation Drift
- E-57 Modified Socket
- E-58 Exhaust Duct and Partition Seal 145S4106-4
- E-59 De-Ice Protection Hinge Half 145R2215-8
- E-60 De-Ice Protection Hinge Pin 145R2215-9
- E-61 Thrust and Yaw Controls Strap 145C1460-10
- E-62 Heater Drain Tube 114E4042-31
- E-63 Heat Airflow Control Tube 114E4072-13
- E-64 Troop Commander Jump Seat Strap 114E4004-7
- E-65 Tackle Block Cable 114E6058-19
- E-66 Acoustic Ceiling Blankets Rope 145E4019-28
- E-67 Acoustic Ceiling Blankets Tube 145E4019-29
- E-68 Acoustic Ceiling Blankets Rope 145E4019-40
- E-69 External Cargo Hook Release Cable 145E5507-2

TM 55-1520-240-23-11

E-70 Emergency Release Cable 114E5090-13
E-71 Hose Assembly MS27371E0460
E-72 Troop Seat Upper Tube 114E4116-23
E-73 Troop Seat Support Tube 114E4079-35
E-74 Cabin First Aid Kit Blanket 114E4014-11
E-75 Hoist Operator Panel Bracket 114E4153-3 and -4
E-76 Hoist Operator Panel Blanket 114E4153-5
E-77 Loading Pole Stowage Angle 114E5105-13
E-78 Loading Pole Stowage Pad 114E5105-15
E-79 Loading Pole Stowage Angle 114E5105-19
E-80 Loading Pole Stowage Angle 114E5105-21
E-81 Hoist Operator Panel Support Clip 114E4108-27
E-82 Hoist Operator Panel Support Clip 114E4108-29
E-83 Hoist Operator Panel Support Strap 114E4108-31
E-84 Support Assembly Cable 114E4108-35
E-85 Forward Transmission Drain Hose TS000-012-0280
E-86 Combining Transmission Drain Hose TS000-012-0300
E-87 Drive Shaft and Gearbox Spacer 114P5003-141
E-88 Engine Bypass Screen Fairing Cushion 114P8073-9
E-89 Engine Bypass Screen Nose Cushion 114P8073-13
E-90 Electrical Lead MS25083-2AA4
E-91 Engine Access Cover Hinge 114P8030-89, -91, -63
E-92 Engine Access Cover Hinge 114P8030-77, -93, -95
E-93 Access Cover Bracket 114P8043-1
E-94 Engine Access Cover Cable 114P8031-61
E-95 External Cargo Hook Manual Release Cover 145E5511-2
E-96 Fwd Pylon Cooling Air Inlet Frame 145S1903-3
E-97 Fwd Pylon Cooling Air Inlet Retainer Strip 145S1903-5
E-98 Deleted
E-99 Fwd Pylon Cooling Air Inlet Strap 145S1903-19
E-100 Fwd Pylon Cooling Air Inlet Retainer Strip 145S1903-21
E-101 Fwd Pylon Cooling Air Inlet Door Hinge 145S1903-16
E-102 Engine Demountable Bracket 114P5018-1
E-103 Engine Demountable Bracket 114P5018-2
E-104 Fwd Pylon Fixed Fairing Hinge 114S1902-117
E-105 Fwd Pylon Fixed Fairing Rubber Seal 114S1902-215
E-106 Cabin Escape Hatch Rubber Seal 114S1619-21
E-107 Cabin Lower Door Retainer 114S1620-21
E-108 Cabin Lower Rubber Seal 114S1620-43
E-109 Electrical Lead MS25083-2AB7

E-110 Packing Material MS28932C09
E-111 Bonding Jumper MS25083-2AC8
E-112 Access Tunnel Cover Seal 114S2915-38
E-113 Leading Edge Fairing Seal 145S4906-31
E-114 Angle 414E3302-23
E-115 Electronics Compartment Hat Section 414E3301-6
E-116 Cabin Floor Plate 114S2554-19
E-117 Gang Channel 114S2554-53
E-118 Gang Channel 114S2554-47
E-119 Access Door Strap 114S4603-19
E-120 Lower Engine Access Panel Cable 114P8052-3
E-121 Lower Engine Access Panel Stud 114P8052-2
E-122 Aft Pylon Hydraulic Bay Door Bracket 145S4607-9
E-123 Engine Drag Strut Slotted Bushing Installation Bar
E-124 Angle 414E3325-6
E-125 Radio Compartment Rack Bracket 145S1621-12
E-126 Corner Angle 145E3102-17
E-127 Seal 114S4901-105
E-128 Chafing Strip 114S4901-213
E-129 Fuel Pod Access Panel Strap 114S5913-8
E-130 Cargo Door Seal Strip 114S6002-161, -162
E-131 Cargo Door Seal Plug 114S6002-105
E-132 Ramp Forward Edge Bearing Pad 145S6554-19
E-133 Ramp Forward Edge Bearing Pad 114S6554-17
E-134 Ramp Forward Edge Bearing Pad 114S6554-15
E-135 Aft Transmission Drip Tray Bumper 234S3607-19
E-136 Auxiliary Fuel Pod Bottom Isolation Strap 114S5824-62
E-137 Aft Transmission Drip Tray Chip Detector Cover Strap 145S3620-11
E-138 Aft Landing Gear Door Chafing Strip (Upper) 114S5905-111
E-139 Aft Transmission Cooler Exhaust Screen 145S3504-2
E-140 Cabin Crown Tunnel Drain Hose 145S1652-19
E-141 Cabin Crown Tunnel Drain Hose 145S1652-18
E-142 Cargo Door Coaling Seal Clamp 114S3908-25, -26
E-143 Fuselage Step Door 114S5602-19
E-144 Cabin Crown Support Angle 114S2710-45
E-145 APU Closure Deck Installation Bracket 114S3157-96
E-146 Aft Transmission Exhaust Duct Seal 145S3701-4
E-147 Aft Transmission Drip Pan Seal Retainer 114S3607-198
E-148 Aft Transmission Drip Pan Seal Retainer 114S3607
E-149 Electric Compartment Access Panel Seal 114S59816-43

- E-150 Nose Door Assembly Hinge Pin 114S1632-23
- E-151 Lower Cockpit Enclosure Door Seal 114S1604-247
- E-152 Forward Transmission Drip Pan Angle 145S1112-10
- E-153 Aft Transmission Drip Tray Chip Detector Cover Seal 145S3620-12
- E-154 Angle Rail (Radar Warning Mount) 145E3002-10
- E-155 Angle Rail (Radar Warning Mount) 145E3002-30
- E-156 Left Hand Electrical Pod Bracket 145E2118-3
- E-157 Left Hand Electrical Pod Bracket 145E2118-6
- E-158 Overhead Panel Channel 414E2029-2
- E-159 Overhead Panel Tee 414E2029-10
- E-160 Overhead Panel Channel 414E2029-14
- E-161 Overhead Panel Channel 414E2029-34
- E-162 Relay Bracket Power Distribution Panel 414E2009-15
- E-163 Auxiliary Pod Plate Isolation Installation 414S5824-13
- E-164 Forward Pylon Work Platform Seal 114S1903-739
- E-165 Forward Pylon Fairing Seal 114S1902-387
- E-166 Forward Pylon Fairing Seal 114S1902-386
- E-167 Upper Cabin Door Shim 114S1621-35
- E-168 Upper Cabin Door Shim 114S1621-33
- E-169 Upper Cabin Door Shim 114S1621-39
- E-170 Upper Cabin Door Shim 114S1621-37
- E-171 Left Hand Electrical Compartment Battery Angle 114E2156-32
- E-172 Left Hand Electrical Compartment Battery Angle 114E2156-31
- E-173 Fuselage Cabin Section Seal 114S2903-31, -33
- E-174 Terminal Board Cover MS18029-2S9, -1S12, -2S16
- E-175 Spacer Beam Cover Panel 114S1655-14
- E-176 Beam Cover Hinge Halves 114S1655-15, -16
- E-177 PDP Housing Assembly Support 145E2158-21
- E-178 PDP Housing Assembly Wire Support 145E2158-33
- E-179 Drive Shaft and Gearbox Fairing Spacer 114P5003-142
- E-180 Drive Shaft and Gearbox Fairing Channel 114P5003-143
- E-181 Drive Shaft and Gearbox Fairing Former 114P5003-144 and -145
- E-182 Drive Shaft and Gearbox Fairing Hinge Half 114P5003-124 and -125
- E-183 Drive Shaft and Gearbox Fairing Hinge Half 114P5003-133 and -134
- E-184 Drive Shaft and Gearbox Fairing Hinge Fin 114P5003-132
- E-185 Drive Shaft and Gearbox Fairing Hinge Pin Retainer 114P5003-135
- E-186 Drive Shaft and Gearbox Fairing Clip 114P5003-108
- E-187 Drive Shaft and Gearbox Fairing Clip 114P5003-91
- E-188 Drive Shaft and Gearbox Fairing Spacer 114P5003-95
- E-189 Cockpit Enclosure Seals 11451608-2, -3, -4, -5, and -6

- E-190 Upper Cockpit Enclosure Seal 114S1602-139
- E-191 Pilots and Copilots Windshield Retainer 114S1716-1
- E-192 Flight Control Support Structure Pile and Hook Tape 145S1121-18 and -19
- E-193 Upper Cabin Door Assembly Seal 114S1621-11
- E-194 Access Door Seal 114S3904-50
- E-195 Access Door Hinge Half 114S3904-17
- E-196 Bellcrank Support Fitting Radius Block 145S1614-2
- E-197 Glare Shield Plate 414S1763-6
- E-198 Glare Shield Angle 414S1763-18
- E-199 Upper Cabin Door Assembly Seal 114S1621-9
- E-200 Ramp Gate Hinge Pin 114S6109-33
- E-201 Cockpit Nose Compartment Door Assembly Angle 114S1632-17 and -18
- E-202 Cockpit Nose Compartment Door Assembly Angle 114S1632-19 and -20
- E-203 Cockpit Nose Compartment Door Assembly Hinge Half 114S1632-21
- E-204 Cabin Door Assembly Bracket 114S1716-5
- E-205 Cabin Door Assembly Plate 114S1716-7
- E-206 Cabin Crown Access Tunnel Cover Installation Hinge Pin 114S2915-23
- E-207 Cabin Structure, Tandem Hooks Clip 145S2617-3 and -4
- E-208 Cabin Structure, Tandem Hooks Clip 145S2617-9
- E-209 Isolation Installation, Auxiliary Fuel Pod Bottom, Strip 114S5824-10
- E-210 Isolation Installation, Auxiliary Fuel Pod Bottom, Shim 114S5824-18
- E-211 Cabin Crown Access Tunnel Cover Installation Seals 114S2915, -39, -40, -41, and -42
- E-212 Forward Landing Gear Access Panel Seal 114S5901-148
- E-213 Forward Landing Gear Access Panel Hinges 114S5901
- E-214 Cabin Crown Access Tunnel Cover Installation Retainer 114S2915-43
- E-215 Cabin Crown Access Tunnel Cover Installation Seal Retainers 114S2915-44, -45, -46, and -47
- E-216 Isolation Installation Auxiliary Fuel Pod Bottom Hinge Components 114S5824-12, -13, and -29
- E-217 Isolation Installation Auxiliary Fuel Pod Bottom Hinge Components 114S5824-14, -15, and -30
- E-218 Isolation Installation Auxiliary Fuel Pod Bottom Retainer 114S5824-22
- E-219 Cabin Crown Access Tunnel Cover Installation Hinge 114S2915-67
- E-220 Isolation Installation Auxiliary Fuel Pod Bottom Strap 114S5824-49
- E-221 Cabin Crown Access Tunnel Cover Installation Half Hinge 114S2915-74
- E-222 Cabin Crown Access Tunnel Cover Installation Strap Assembly 114S2915-79
- E-223 Pod Attachment Hinge Pins 11485701-1, -3, -5, -7, -9, and -10
- E-224 Deleted
- E-225 Deleted
- E-226 Directional Stability Strake Former 114S6505-15 and -16
- E-227 Directional Stability Strake Former 114S6505-17 and -18

- E-228 Engine Harness Retention Tool SK32193-1 and -5
- E-229 Isolator Panel, Main Fuel Cell-Filler 114S5823-10
- E-230 Isolator Panel, Main Fuel Cell-Hinge Half 114S5823-18
- E-231 Isolator Panel, Main Fuel Cell-Hinge Assemblies 114S5823
- E-232 Isolator Panel, Main Fuel Cell-Filler 114S5823-26
- E-233 Isolator Panel, Main Fuel Cell-Filler 114S5823-27
- E-234 Isolator Panel, Main Fuel Cell-Strip 114S5823-31 and -32
- E-235 Isolator Panel, Main Fuel Cell-Filler 114S5823-38
- E-236 Isolator Panel, Main Fuel Cell-Hinge Half 114S5823-57
- E-237 Isolator Panel, Main Fuel Cell-Hinge Half 114S5823-58
- E-238 Isolator Panel, Main Fuel Cell-Hinge Pin 114S5823-62
- E-239 Isolator Panel, Auxiliary Fuel Pod Bottom-Filler 114S5824-24
- E-240 Isolator Panel, Auxiliary Fuel Pod Bottom-Filler 114S5824-10
- E-241 Isolator Panel, Auxiliary Fuel Pod Bottom-Strip 114S5824-11
- E-242 Isolator Panel, Auxiliary Fuel Pod Bottom-Shim 114S5824-12
- E-243 Handgrip Installation Drain Tube 114S2610-31 and -74
- E-244 Cabin Crown Stiffener Clip 114S2710-41
- E-245 Cargo Ramp Seal Retainer 114S6608-15, -25, and -26
- E-246 Cargo Ramp Seal Filler 114S6608-17
- E-247 Cargo Ramp Seal Filler 114S6608-19
- E-248 Cargo Ramp Seal Splice Channel 114S6608-27
- E-249 Cargo Ramp Seal 114S6608-33
- E-250 Cargo Ramp Seal Retainer 114S6608-35
- E-251 Cargo Ramp Hinge Pin 114S3613-39 and -43
- E-252 Cargo Ramp Hinge 114S3613-31 and -32
- E-253 Cargo Ramp Hinge 114S3613-35, -36, -37, and -38
- E-254 Center Ramp Floor Panel 114S6551-11
- E-255 Center Ramp Floor Panel 114S6551-13 and -14
- E-256 Center Ramp Floor Panel 114S6551-15 and -16
- E-257 Center Ramp Floor Panel 114S6551-17 and -18
- E-258 Ramp Gate Hinge Pin 114S6109-32
- E-259 Aft Transmission Drip Pan Pile Tape 114S3607-49
- E-260 Aft Transmission Drip Pan Hinge Half 114S3607-79
- E-261 Aft Transmission Drip Pan Hinge Pin 114S3607-81
- E-262 Aft Transmission Drip Pan Hinge Half 114S3607-163
- E-263 Aft Transmission Drip Pan Hinge Pin 114S3607-167
- E-264 Aft Transmission Drip Pan Retainer 114S3607-191 and -195
- E-265 Aft Transmission Drip Pan Strap 145S3616-2
- E-266 Chip Detector Fuzz Burn-Off Test Set Test 145-02~5400-1
- E-267 Upper Cabin Door Escape Hatch Rubber Seal 1141621-5 and Seal Filler 114S1621-7

- E-268 Out Rigger Assembly 1730CH47-002 for Vertical Pylon Handling Skid 114E5856-22
- E-269 Electrical Lead MS25083-1AB3
- E-270 Engine Inlet Lower Screen Hinge Assembly MS20001P8-2075
- E-271 Lower Cabin Door Seal Retaining Strips VS25201-030-1935 and VS25201-030-2560
- E-272 Electrical Lead MS25083-1BB7 and MS25083-1BB10
- E-273 Fold Out Step Assembly Half Hinge 114S5612-18 and -12
- E-274 Fold Out Step Assembly Hinge Pin 114S5612-19
- E-275 Main Fuel Pod Isolator Panel Channel 145S5805-2
- E-276 Electrical Lead MS25083-7BC10
- E-277 Main Fuel Pod Isolator Strip 114S5823-36
- E-278 Auxiliary Fuel Pod Isolator Installation Filler 114S5824-26
- E-279 Forward Auxiliary Fuel Pod Transition Fairing Seal 145S2907-3
- E-280 Aft Transmission Drip Tray Installation Seals 145S3607-181 and -187
- E-281 Ramp Forward Edge Bearing Pad 114S6554-19
- E-282 Cargo Door Seals 114S6002-182, -183, and -184
- E-283 Cargo Door Seals 114S6002-175
- E-284 Ramp Work Platform Brace Hinge Pin 114S6701-37
- E-285 Ramp Work Platform Brace Hinge Half 114S6701-32
- E-286 Ramp Work Platform Brace Hinge Half 114S6701-31
- E-287 Ramp Work Platform Brace Hinge Half 114S6701-33
- E-288 Ramp Work Platform Brace Attachment 114S6701-36
- E-289 Electrical Lead MS25083-2BB10
- E-290 Pod Work Platform Fairing Installation Half Hinge 114S5551-89
- E-291 Pod Work Platform Fairing Installation Hinge Half 114S5551-85, -86, -87, and -88
- E-292 Pod Work Platform Fairing Installation Hinge Pin 114S5551-95
- E-293 APU Drip Tray Mod Installation Tee 145S3617-4 and -5
- E-294 APU Access Panel Installation Hinge Half 114S3615-27
- E-295 APU Access Panel Installation Hinge Half 114S3615-29
- E-296 APU Access Panel Installation Hinge Pin 114S3615-31
- E-297 Aft Landing Gear Pod Fairing Installation Hinge Half 114S5910-35
- E-298 Aft Landing Gear Pod Fairing Installation Seals 114S5910-27, and -28
- E-299 Aft Landing Gear Access Panel Assembly Hinge Half 114S5909-55
- E-300 Aft Landing Gear Access Panel Assembly Hinge Pin 114S5909-56
- E-300.1 Electrical Lead MS 25083-3BB6
- E-301 Electrical Lead MS25083-3BB7
- E-302 Electrical Lead MS25083-2AC7
- E-303 Engine Pylon Fairing Installation Seal 114S3902-241, -247, -365, -366, -379, and -380
- E-304 Engine Pylon Fairing Installation Seals 234S3902-19 and -20
- E-305 Hinged Lower Panel Access Cover Assembly Hinge Pin 114P8032-45
- E-306 Hinged Lower Panel Access Cover Assembly Half Hinge 114P8032-93

TM 55-1520-240-23-11

- E-307 Hinge Lower Panel Access Cover Assembly Seal 114P8032-39
- E-308 Installation of Engine Access Door Assembly Half Hinge 114S3915-63 and -64
- E-309 Hydraulic Test Panel Access Door Installation Seats 114S3905-47, -49, -65, and -67
- E-310 Aft Pylon Latch Shim 145S4706-36
- E-311 Cargo Hook Release Switch Guard EGD-1001
- E-312 Ball Staking Tool
- E-313 Cargo Hook Light Switch Box
- E-314 Balance Control Bracket
- E-315 Doubler, Cargo Hook Light
- E-316 C-Box Doors Latch Assembly
- E-317 Remote Ramp Control Valve Test Set
- E-318 Engine Fuel Depreservation Drain Line
- E-319 Thrust LVDT Test Harness
- E-320 Rotary Wing Support

PART NUMBER AND E NUMBER INDEX

Part Number	Appendix E Number
HP437-PF1	E-23
HP973AT-3	E-27
HP973AT-4	E-25
HP973AT-5	E-24
MS18029-2S9, -1S12, and -2S16	E-174
MS20001P8-2075	E-270
MS25083-1AB3	E-269
MS25083-1BB7	E-272
MS25083-1BB10	E-272
MS25083-2AA4	E-90
MS25083-2AB7	E-109
MS25083-2AC7	E-302
MS25083-2AC8	E-111
MS25083-2BB10	E-289
MS25083-3BB6	E-300.1
MS25083-3BB7	E-301
MS25083-7BC1O	E-276
MS27371E0460	E-71
MS28932C09	E-110
SK31250	E-53
TE145-02-5400-1	E-266
TS000-012-0280	E-85
TS000-012-0300	E-86
VS25201-030-1935	E-271
VS25201-030-2560	E-271
114E2156-31	E-172
114E2156-32	E-171
114E4004-7	E-64
114E4014-11	E-74
114E4042-31	E-62
114E4072-13	E-63
114E4079-35	E-73
114E4108-27	E-81
114E4108-29	E-82
114E4108-31	E-83
114E4108-35	E-84
114E4116-23	E-72
114E4153-3 and -4	E-75

Part Number	Appendix E Number
114E4153-5	E-76
114E5105-13	E-77
114E5105-15	E-78
114E5105-19	E-79
114E5105-21	E-80
114E5090-13	E-70
114E6058-19	E-65
114P5003-91	E-187
114P5003-95	E-188
114P5003-108	E-186
114P5003-124 and -125	E-182
114P5003-132	E-184
114P5003-133 and -134	E-183
114P5003-135	E-185
114P5003-141	E-87
114P5003-142	E-179
114P5003-143	E-180
114P5003-144 and -145	E-181
114P5018-1	E-162
114P5018-2	E-103
114P8030-63, -89, and -91	E-91
114P8030-77, -93, and -95	E-92
114P8031-61	E-94
114P8032-39	E-307
114P8032-45	E-305
114P8032-93	E-306
114P8032-94	E-308
114P8043-1	E-93
114P8052-2	E-121
114P8052-3	E-120
114P8073-9	E-88
114P8073-13	E-89
114P8080-18	E-49
114R1737-2	E-44
114S1602-139	E-190
114S1608-2, -3, -4, -5, and -6	E-189
114S1604-247	E-151
114S1619-21	E-106
114S1620-21	E-107

Part Number	Appendix E Number
114S1620-43	E-108
114S1621-5 and -7	E-267
114S1621-9	E-199
114S1621-11	E-193
114S1621-37	E-170
114S1621-33	E-168
114S1621-35	E-167
114S1621-39	E-169
114S1632-17 and -18	E-201
114S1632-19 and -20	E-202
114S1632-23	E-150
114S1655-14	E-175
114S1655-15 and -16	E-176
114S1717-1	E-191
114S1716-5	E-204
114S1716-7	E-205
114S1902-117	E-104
114S1902-215	E-105
114S1902-386	E-166
114S1902-387	E-165
114S1903-739	E-164
114S2554-19	E-116
114S2554-47	E-118
114S2554-53	E-117
114S2610-31 and -74	E-243
114S2710-41	E-244
114S2710-45	E-144
114S2903-31-33	E-173
114S2915-23	E-206
114S2915-38	E-112
114S2915-39, -40, -41, and -42	E-211
114S2915-43	E-214
114S2915-44, -45, -46, and -47	E-215
114S2915-67	E-219
114S2915-74	E-221
114S2915-79	E-222
114S3157-96	E-145
114S3607-182 thru -186, -188, and -189	E-148
114S3607-49	E-259

Part Number	Appendix E Number
114S3607-79	E-260
114S3607-81	E-261
114S3607-163	E-262
114S3607-167	E-263
114S3607-181 and -187	E-280
114S3607-191 and -195	E-264
114S3607-198	E-147
114S3613-31 and -32	E-252
114S3613-35, -36, -37, and -38	E-253
114S3613-39 and -43	E-251
114S3615-27	E-294
114S3615-29	E-295
114S3615-31	E-296
114S3902-241, -247, -365, -366, -379, and -380	E-303
114S3904-17	E-195
114S3904-50	E-194
114S3905-47, -49, -65, and -67	E-309
114S3908-25, -26	E-142
114S3915-63 and -64	E-309
114S4603-19	E-119
114S4901-105	E-127
114S4901-213	E-128
114S5551-85, -86, -87, and -88	E-291
114S5551-89	E-290
114S5551-95	E-292
114S5602-19	E-143
114S5612-12	E-273
114S5612-18	E-273
114S5612-19	E-274
114S5701-1, -3, -5, -7, -9, and -10	E-223
114S5727-13, -14, -15, and -22	E-224
114S5727-17, -18, -23, and -26	E-225
114S5823-Hinge Assemblies	E-231
114S5823-10	E-229
114S5823-18	E-230
114S5823-26	E-232
114S5823-27	E-233
114S5823-31 and -32	E-234
114S5823-36	E-277

Part Number	Appendix E Number
114S5823-38	E-235
114S5823-57	E-236
114S5823-58	E-237
114S5823-62	E-238
114S5824-10	E-209
114S5824-12, -13, and -29	E-216
114S5824-14, -15, and -30	E-217
114S5824-18	E-210
114S5824-22	E-211
114S5824-24	E-239
114S5824-26	E-278
114S5824-49	E-220
114S5824-62	E-136
114S5901-Hinge Assemblies	E-213
114S5905-111	E-138
114S5909-55	E-299
114S5909-56	E-300
114S5913-8	E-129
114S5916-43	E-149
114S6002-105	E-131
114S6002-161, -162	E-130
114S6002-175	E-283
114S6002-182, -183, and -184	E-282
114S6109-32	E-258
114S6109-33	E-200
114S6505-15 and -16	E-226
114S6505-17 and -18	E-227
114S6551-11	E-254
114S6551-13 and -14	E-255
114S6551-15 and -16	E-256
114S6551-17 and -18	E-257
114S6554-15	E-134
114S6554-17	E-133
114S6554-19	E-281
114S6608-15, -25, and -26	E-245
114S6608-17	E-246
114S6608-19	E-247
114S6608-27	E-248
114S6608-33	E-249

Part Number	Appendix E Number
114S6608-35	E-250
114S6701-31	E-286
114S6701-32	E-285
114S6701-33	E-287
114S6701-36	E-288
114S6701-37	E-284
145C1460-10	E-61
145E2118-3	E-156
145E2118-6	E-157
145E2158-21	E-177
145E2158-33	E-178
145E3002-10	E-154
145E3002-30	E-155
145E3102-17	E-126
145E4019-28	E-66
145E4019-29	E-67
145E4019-40	E-68
145E5507-2	E-69
145E5511-2	E-95
145G5278-20	E-34
145L2330-2 and -3	E-53
145R2215-8	E-59
145R2215-9	E-60
145S1112-10	E-152
145S1121-18 and -19	E-192
145S1614-2	E-196
145S1621-12	E-125
145S1652-18 and -22	E-141
145S1652-19, -20, and -21	E-140
145S1903-3	E-96
145S1903-5	E-97
145S1903-19	E-99
145S1903-16	E-101
145S1903-21	E-100
145S2617-3 and -4	E-207
145S2617-9	E-208
145S2907-3	E-279
145S3504-2	E-139
145S3616-2	E-265

Part Number	Appendix E Number
145S3617-4	E-293
145S3617-5	E-293
145S3620-11	E-137
145S3620-12	E-153
145S3701-4	E-146
145S4106-4	E-58
145S4607-9	E-122
145S4906-31	E-113
145S5805-2	E-275
145S6554-19	E-132
145P5018-1	E-102
1730CH47-002	E-268
234P5052-3, -8, and -9	E-48
234P5052-4	E-47
234P5052-7	E-46
234R2205-1	E-54
234S3607-19	E-135
234S3902-19 and -20	E-304
414E2009-15	E-162
414E2029-2	E-158
414E2029-10	E-159
414E2029-14	E-160
414E2029-34	E-161
414E3301-6	E-115
414E3302-23	E-114
414E3325-6	E-124
414S1763-6	E-197
414S1763-18	E-198
414S5824-10	E-240
414S5824-11	E-241
414SS824-12	E-242
414S5824-13	E-163

NOTES:

1. FABRICATE FROM METAL PLATE QQ-S-635, NSN 9515-00-596-1894.
2. ALL DIMENSIONS IN INCHES.
3. TOLERANCES:
 .X = ±.03
 .XX = ±.03
 .XXX = .010
 ANGLES ±2°
4. BREAK SHARP EDGES.
5. SURFACE TREATMENT PER MIL-C-13924CL1.

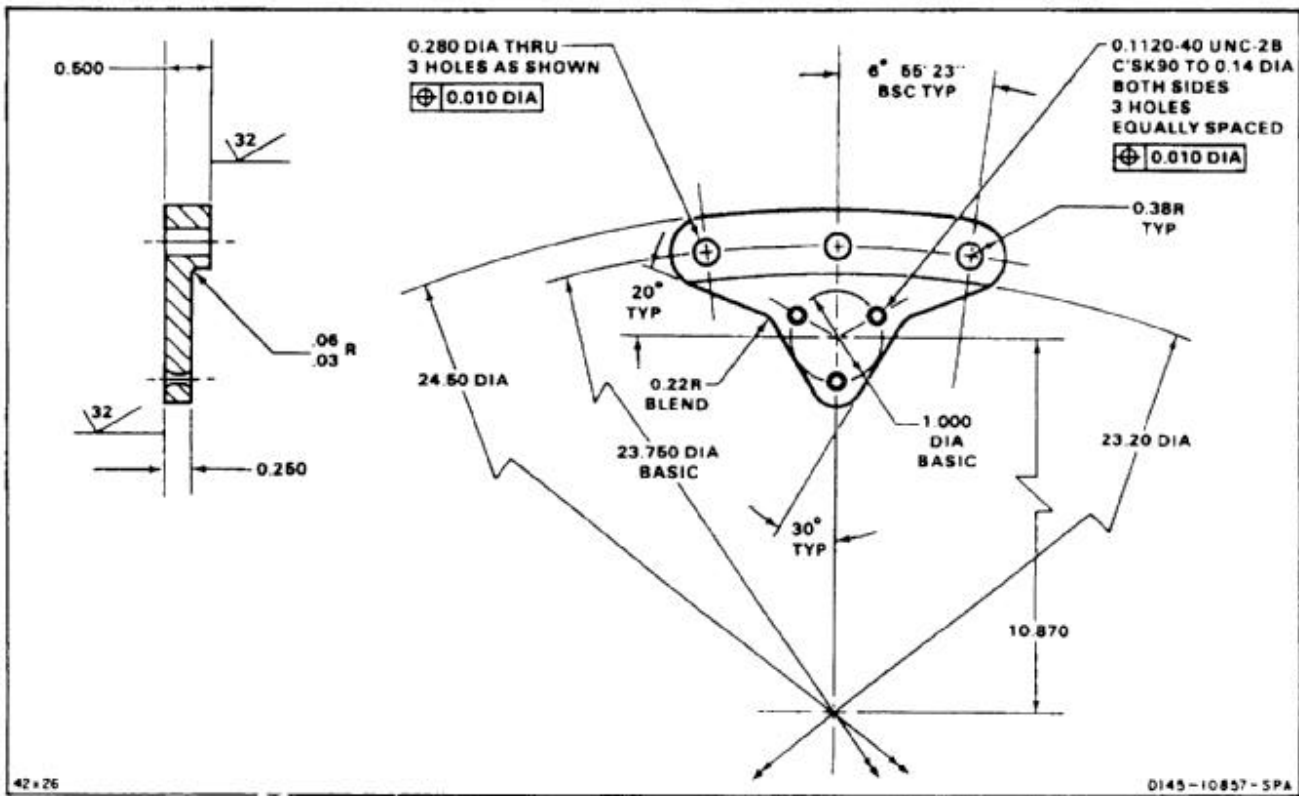

END OF TASK

NOTES:

1. FABRICATE FROM METAL BAR QQ-S-763, NSN 9510-00-975-2640.
2. ALL DIMENSIONS IN INCHES
3. FOR REMOVAL/INSTALLATION OF END PLUGS ON RAMP CONTROL VALVE 114HS111-1.

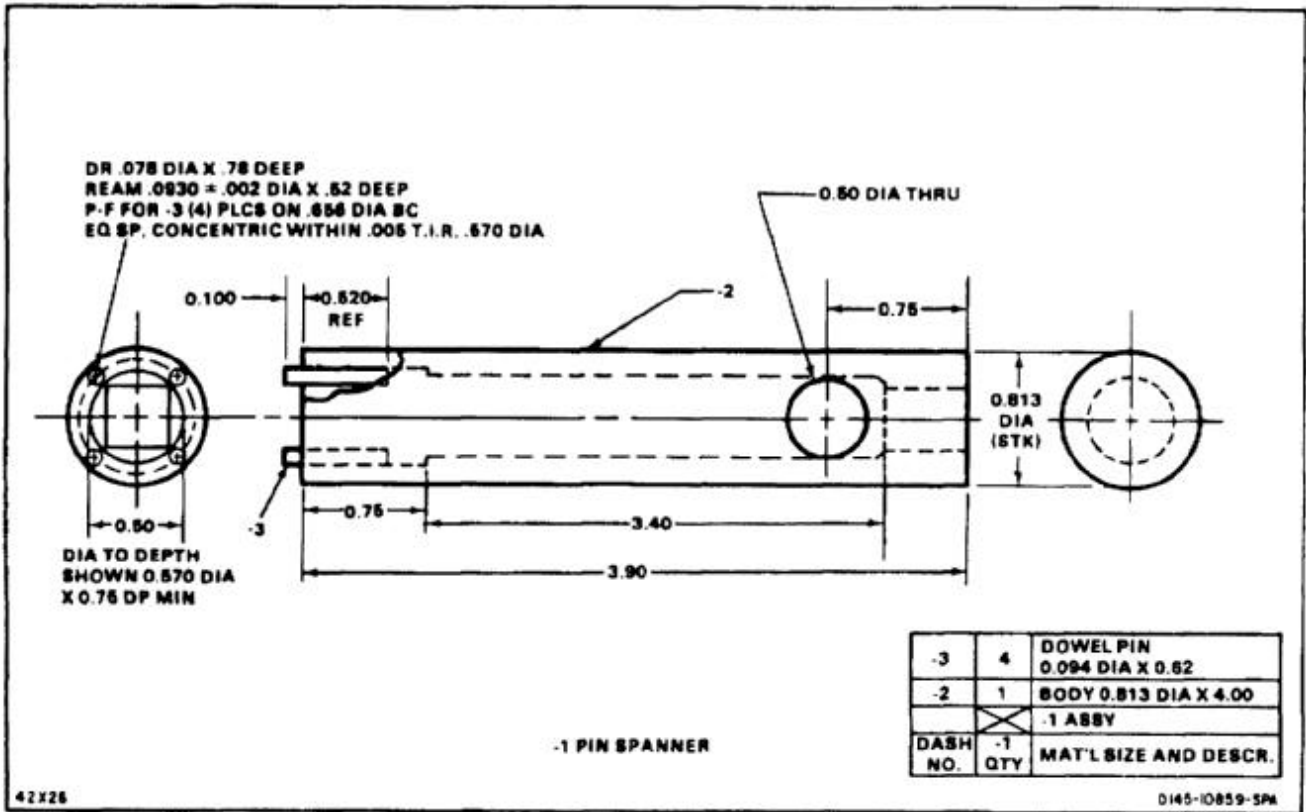

END OF TASK

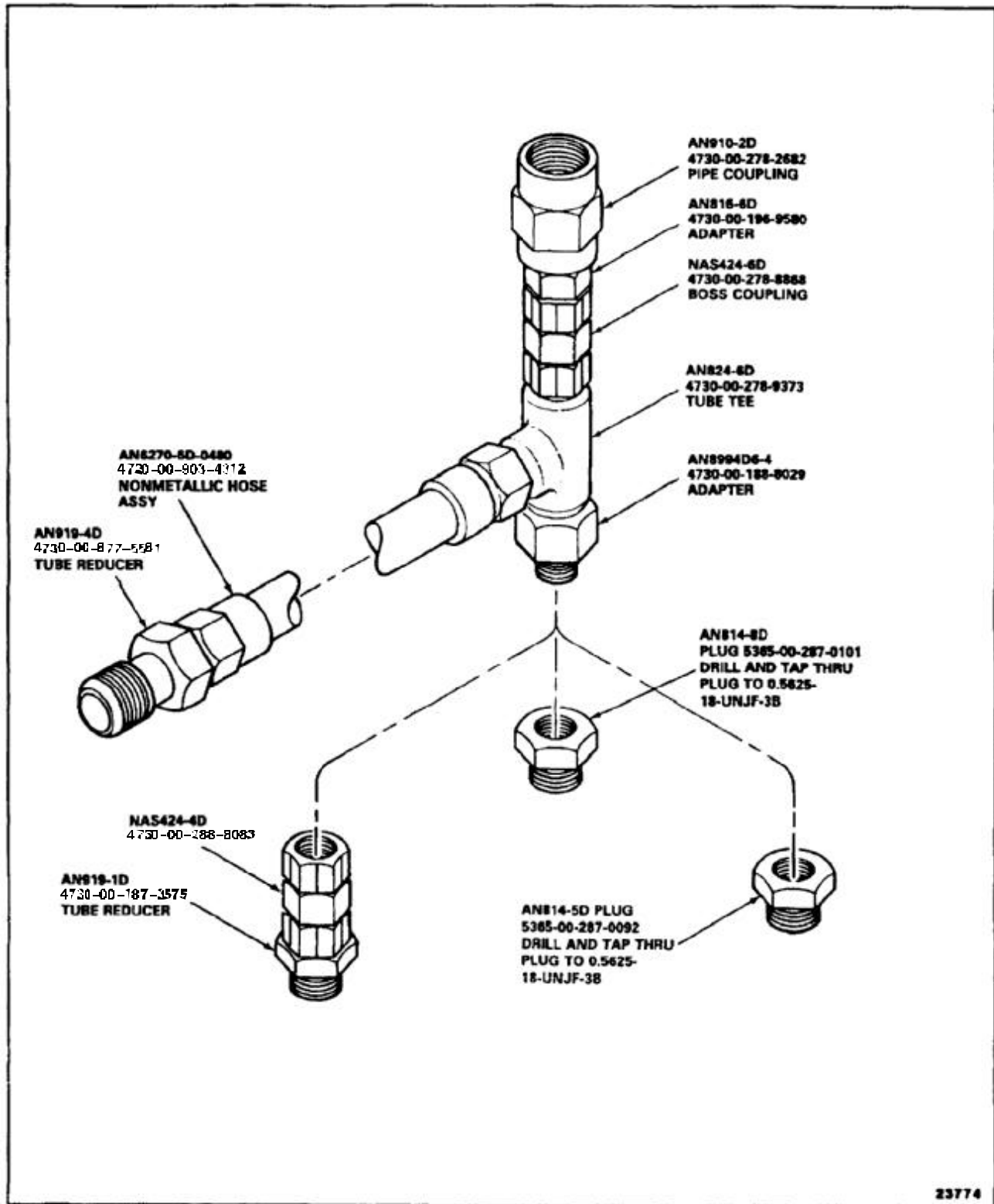

END OF TASK

NOTES:

1. FABRICATE FROM METAL PLATE PER
QQ-A-250/4, NSN 9535-00-232-6948
2. ALL DIMENSIONS IN INCHES.

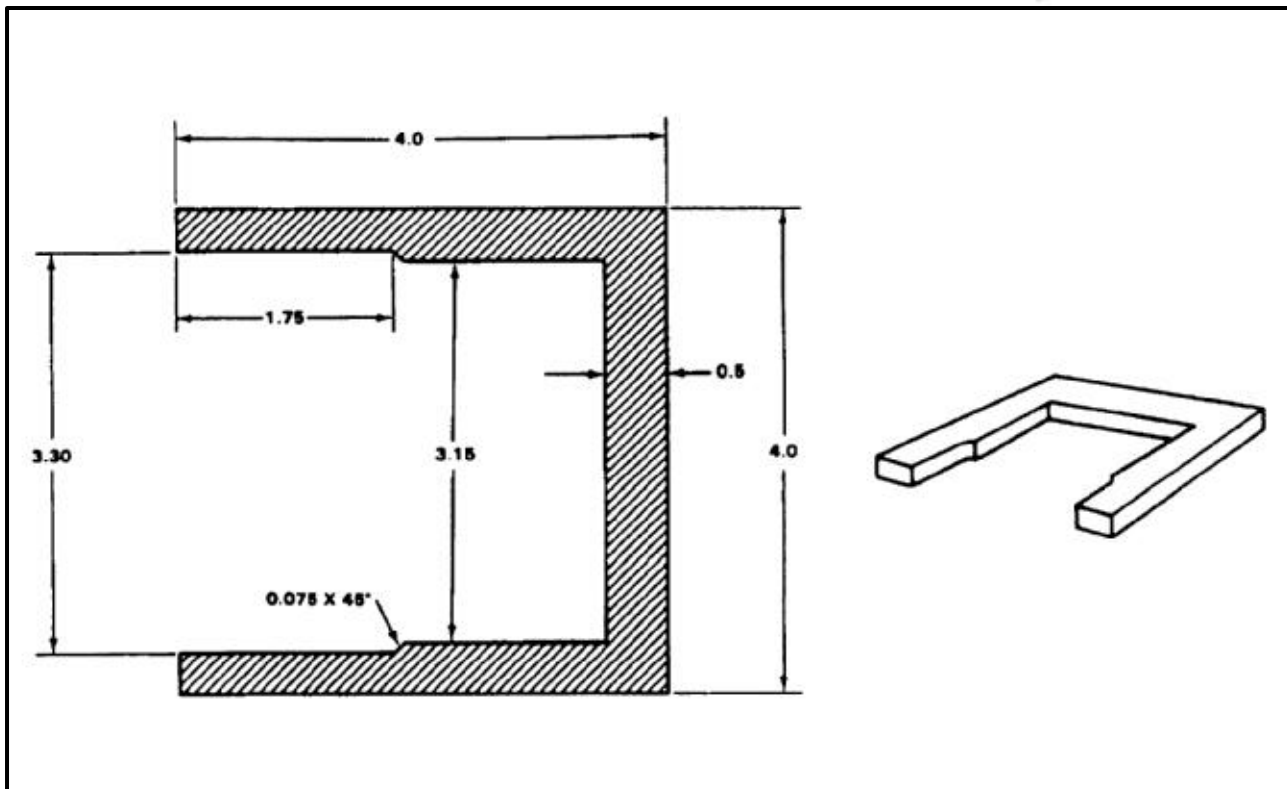

END OF TASK

E-6 LCT SHAFT ROTATION LEVER**E-6****NOTES:**

1. FABRICATE FROM METAL SHEET QQ-A-250/5,
NSN 9535-00-232-0532.
2. ALL DIMENSIONS IN INCHES.

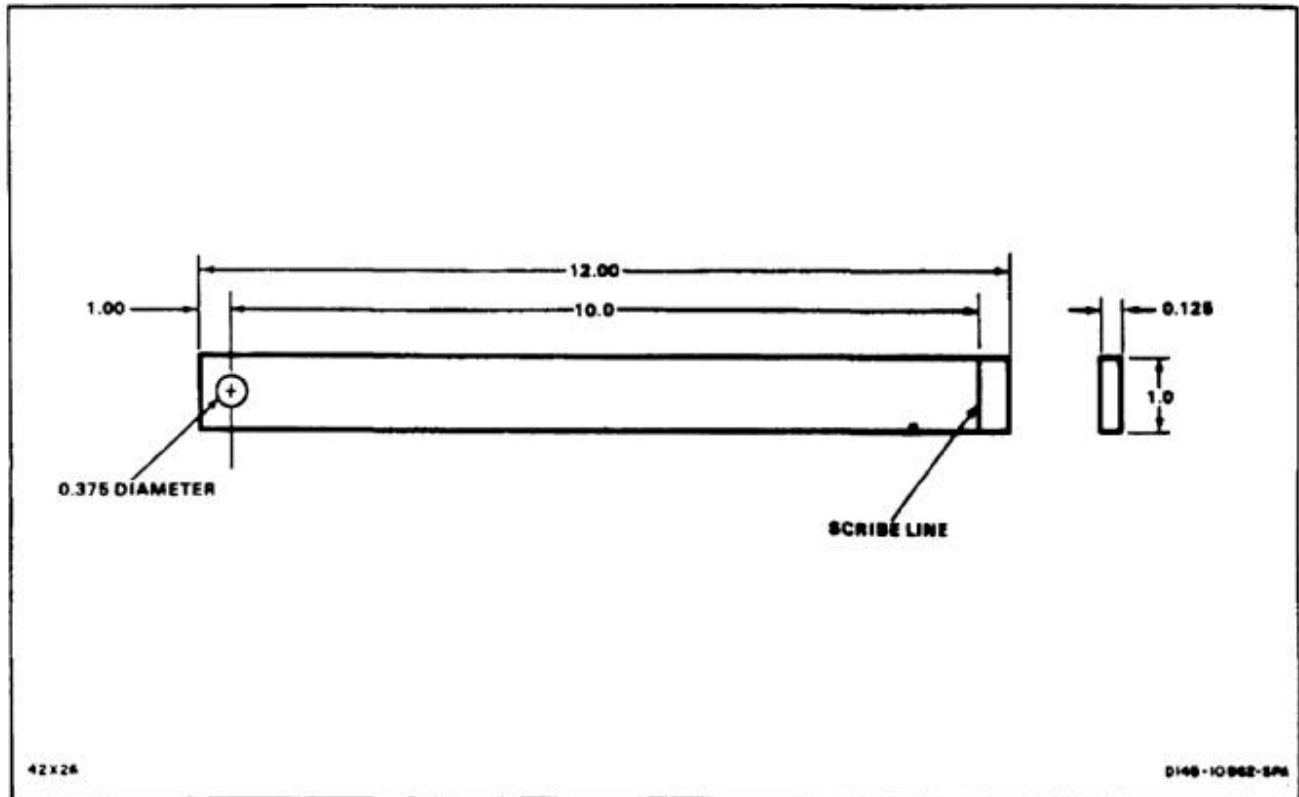

END OF TASK

NOTES:

1. FABRICATE FROM METAL BAR QQ-A-225/6,
NSN 9530-01-051-0175.
2. ALL DIMENSIONS IN INCHES.

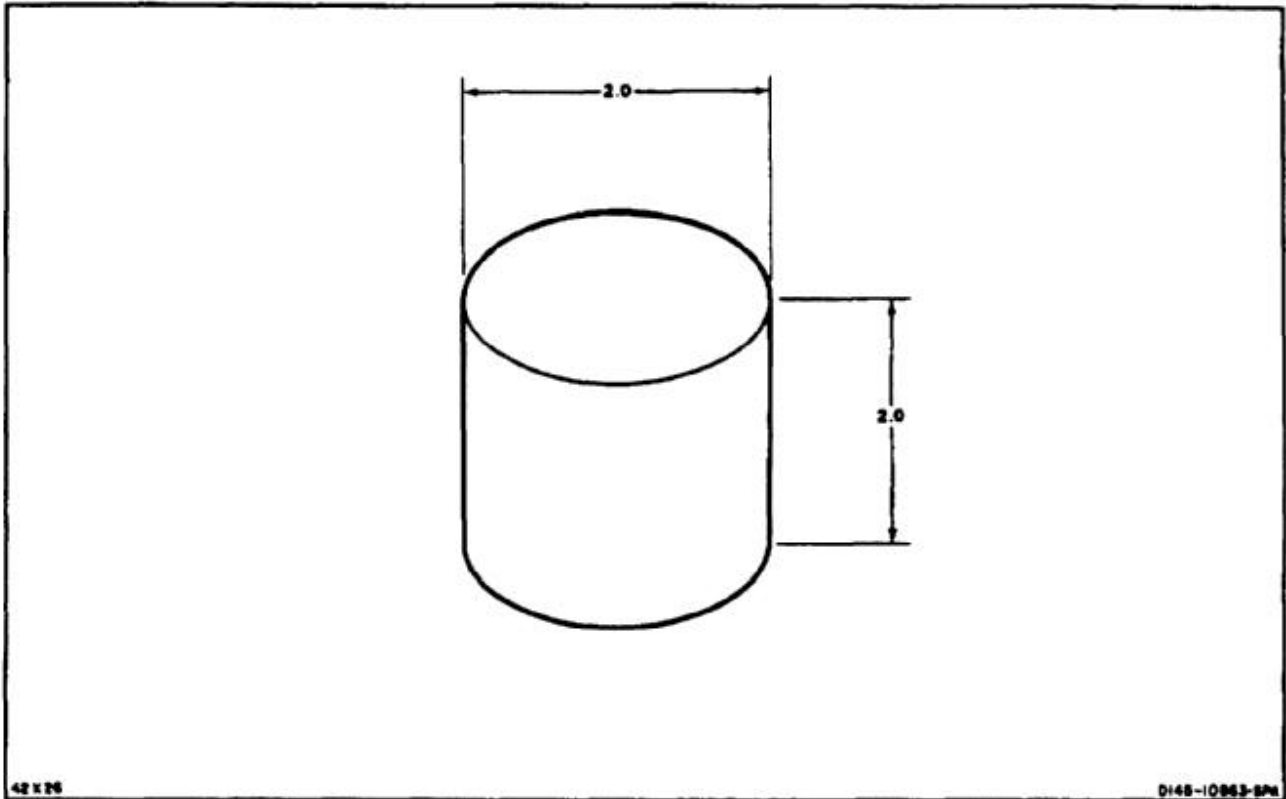

END OF TASK

E-8 SLEEVE BEARING REMOVAL ADAPTER**E-8****NOTES:**

1. FABRICATE FROM METAL BAR QQ-A-200/3,
NSN 9530-00-236-1378.
2. ALL DIMENSIONS IN INCHES.

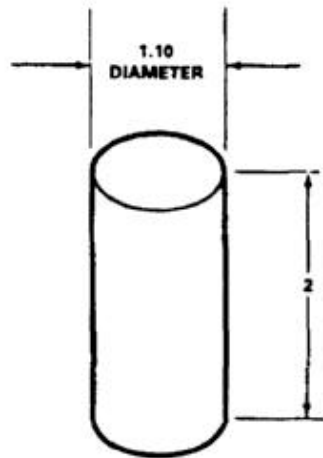

END OF TASK

NOTES:

1. FABRICATE FROM METAL BAR QQ-A-225/6,
NSN 9530-00-228-9313
2. ALL DIMENSIONS IN INCHES.

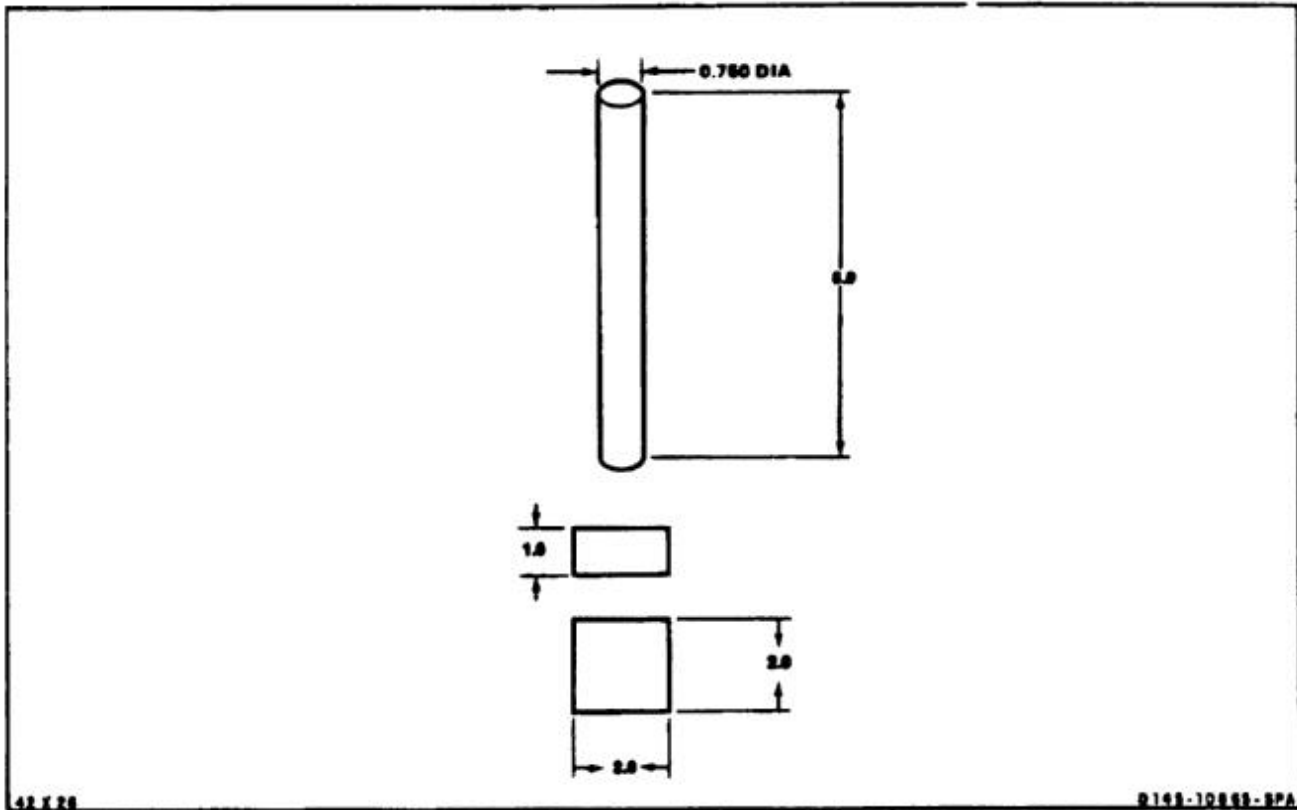

END OF TASK

NOTES:

1. FABRICATE FROM METAL BAR QQ-A-225/9,
NSN 9530-00-244-6931
2. ALL DIMENSIONS IN INCHES.

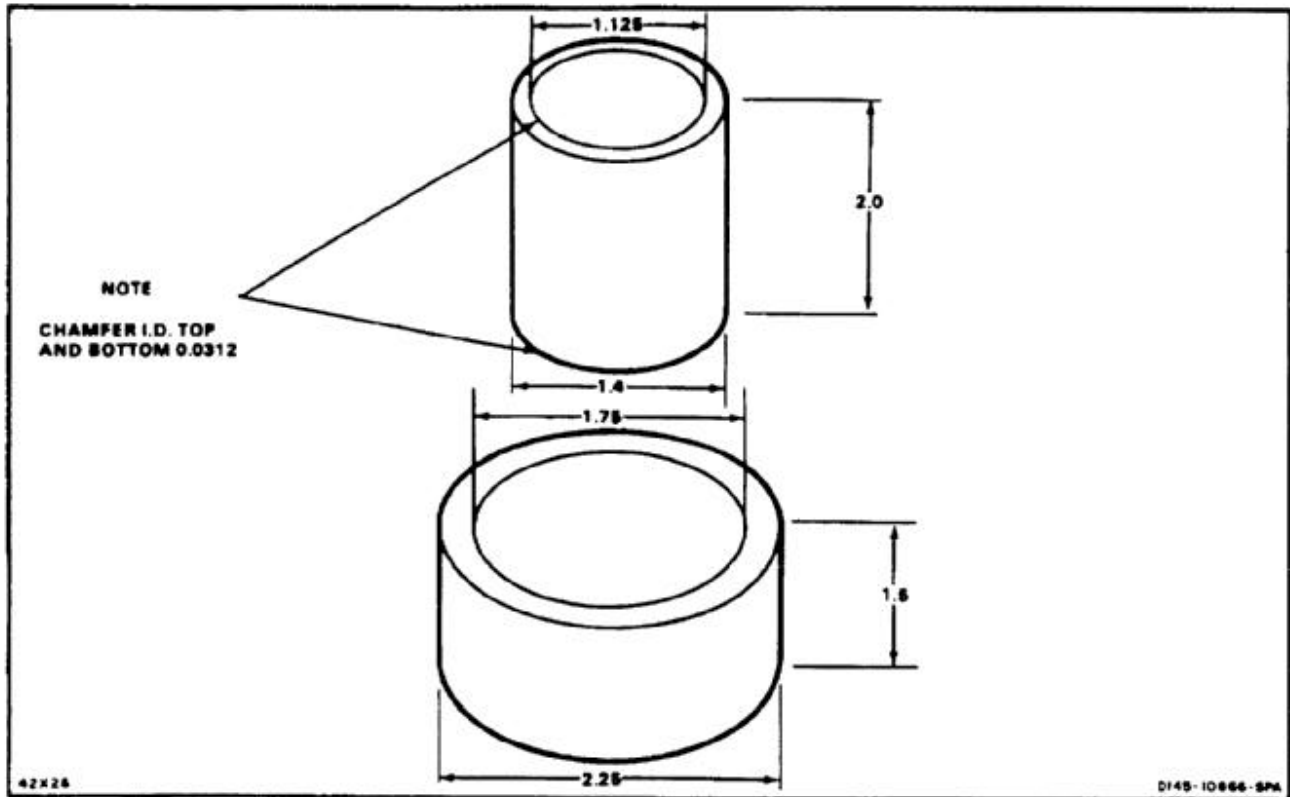

END OF TASK

NOTES:

1. FABRICATE FROM METAL SHEET
MIL-S-18729, NSN 9515-00-269-5824.
2. ALL DIMENSIONS IN INCHES.
3. WELD PER MIL-W-8611A.

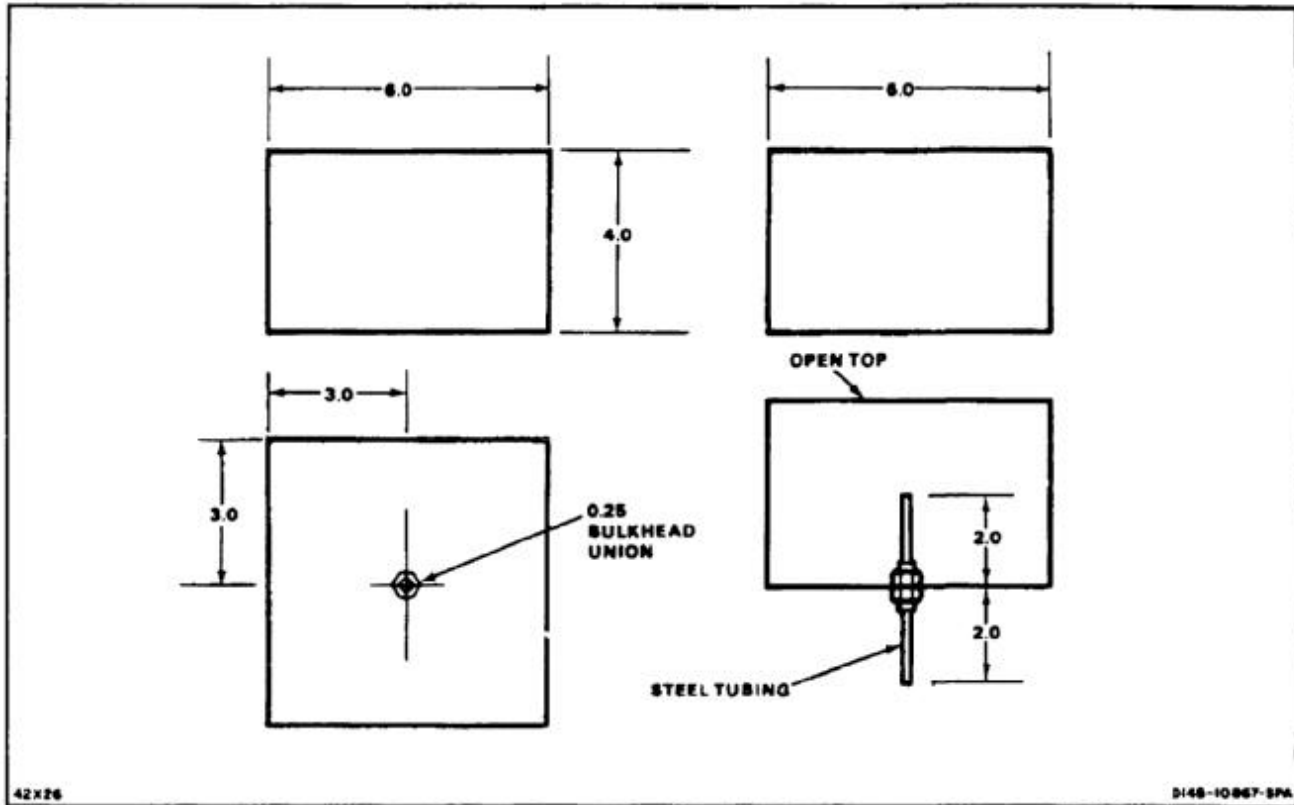

END OF TASK

NOTES:

1. FABRICATE FROM METAL SHEET
MIL-S-18729, NSN 9515-00-269-5824.
2. ALL DIMENSIONS IN INCHES.
3. WELD PER MIL-W-8611A.

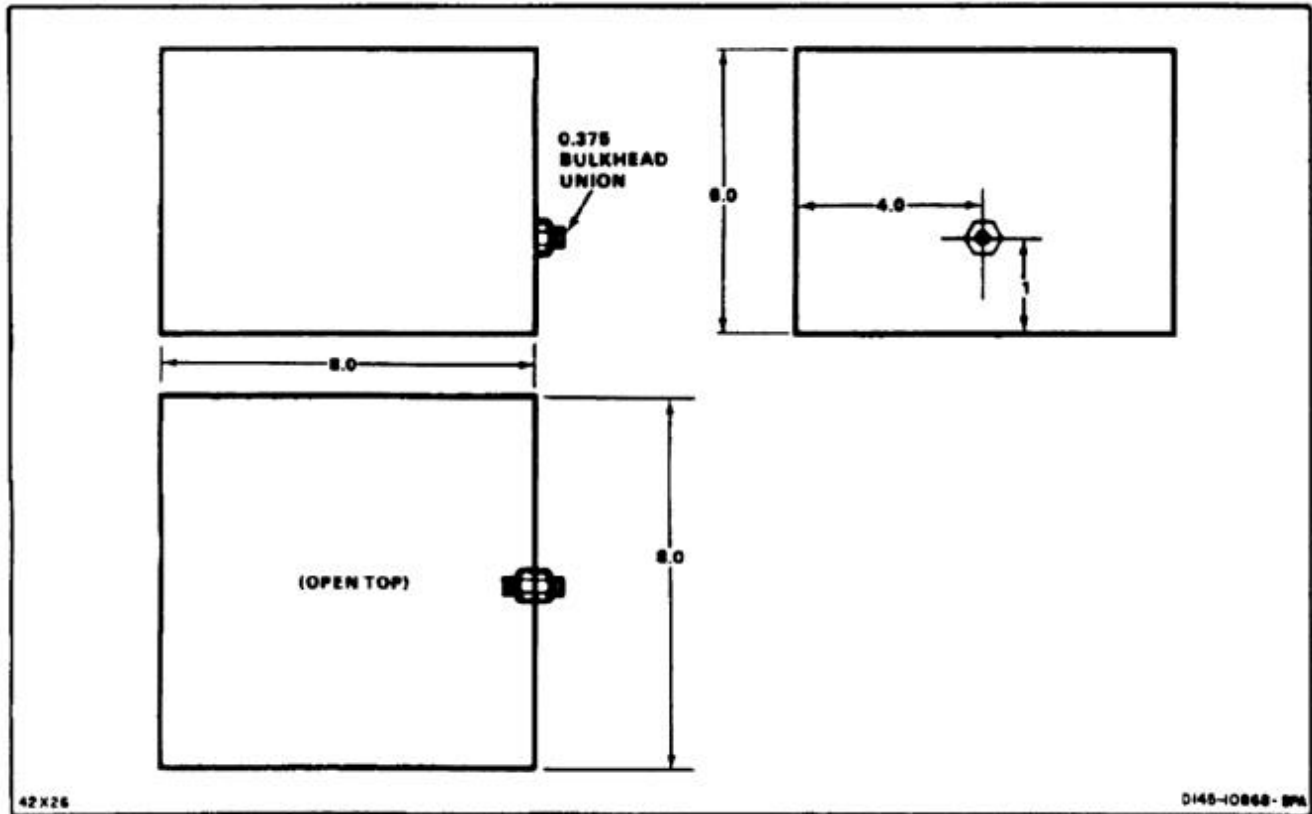

END OF TASK

NOTES:

1. FABRICATE FROM:
 -2 METAL PLATE QQ-S-766,
 NSN 9591-00-051-1840
 -3 AND -4 METAL BAR QQ-S-763,
 NSN 9515-00-975-2640
2. ALL DIMENSIONS IN INCHES.

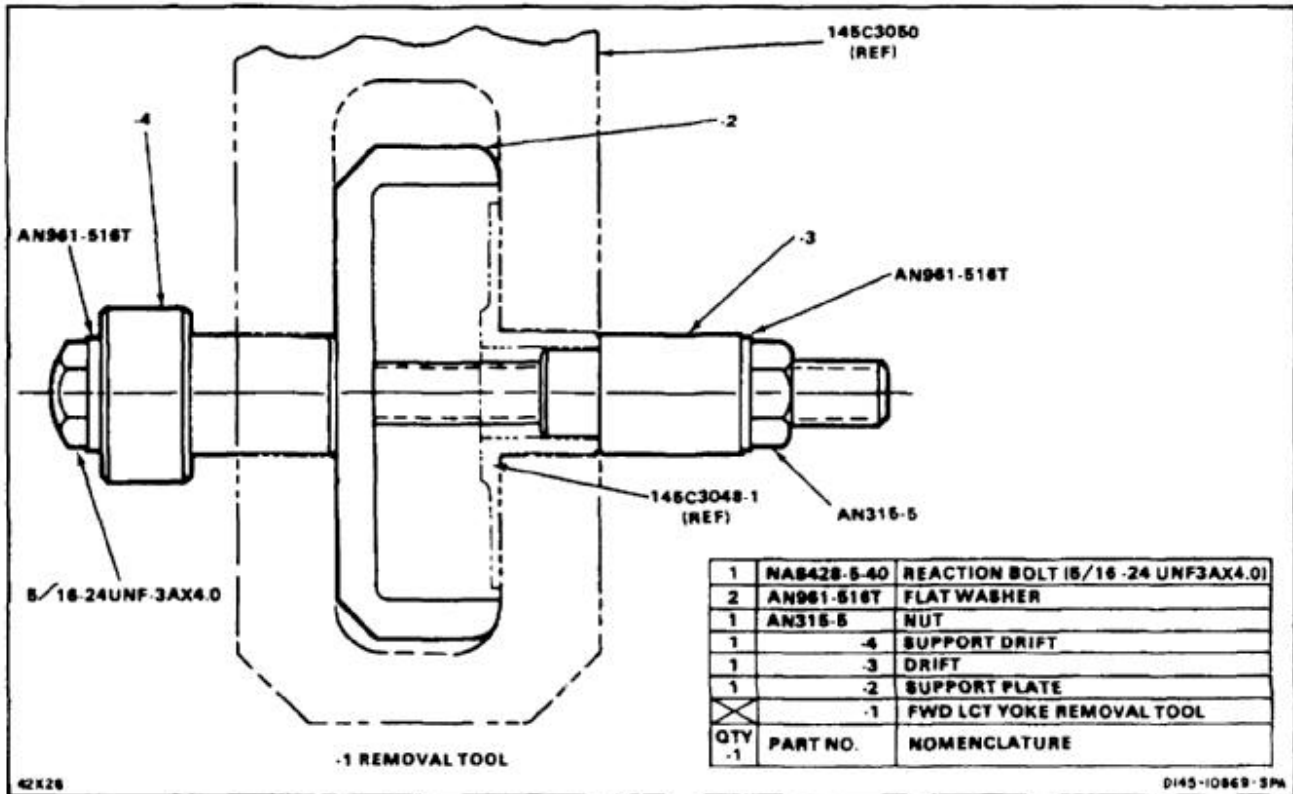

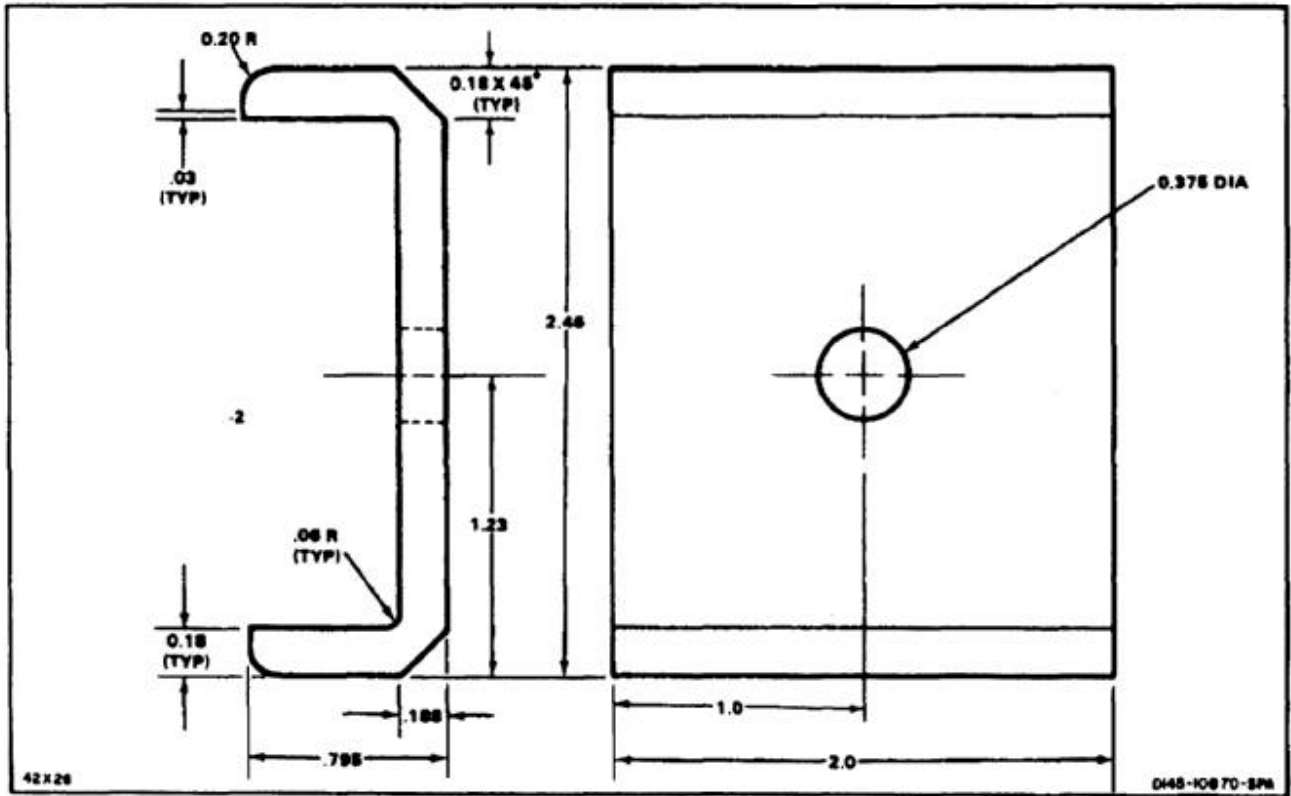

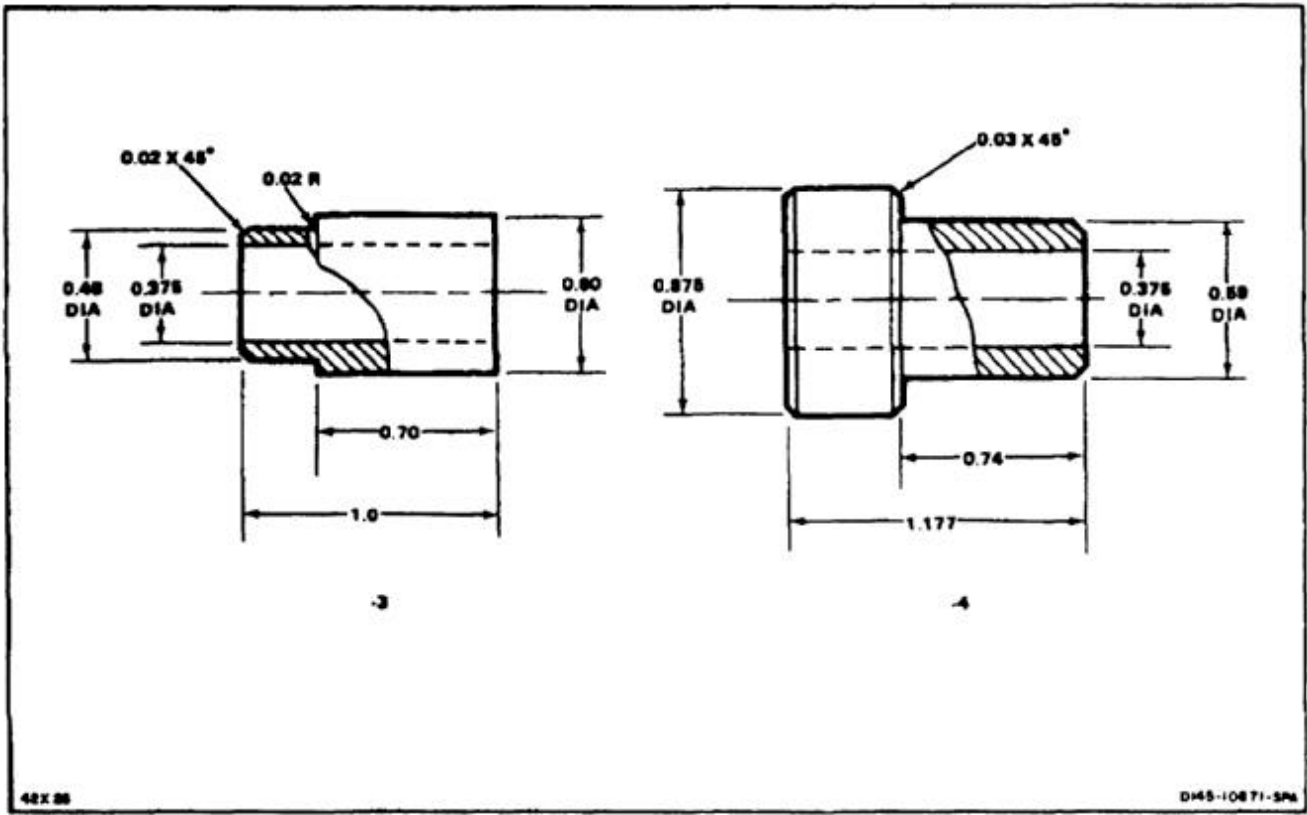

END OF TASK

QTY REQ'D	QTY REQ'D	PART NO.	TITLE	MATERIAL	NSN
-2	-1				
2		MS35338-139	WASHER, LOCK		5310-01-249-9376
2		AN960XC416	WASHER, FLAT		5310-00-419-6566
2		AN4C24	BOLT	1/4-28UNF-3A X 2.5L	5306-00-151-2446
2		AN315C4R	NUT	1/4-28UNF-3B	5310-00-268-6023
	1	-5	REACTION PLATE	304 CRES 2.37 DIA. X .18	9515-00-204-4571
	1	-4	REACTION TUBE	304 CRES 2.37 O.D. X .18W X 1.3L	9510-01-274-0429
2		-3	PUSHER	304 CRES 2.1 X 4.9 X 5.4	9510-01-010-2546
	1	-2	PUSHER ASSY		
		-1	REMOVAL TOOL		

NOTE

ALL DIMENSIONS IN INCHES.

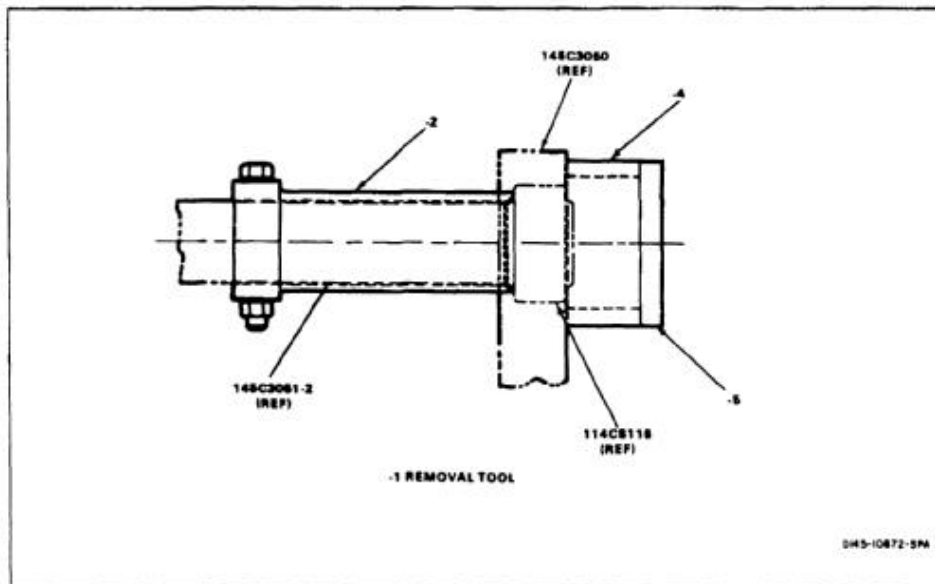

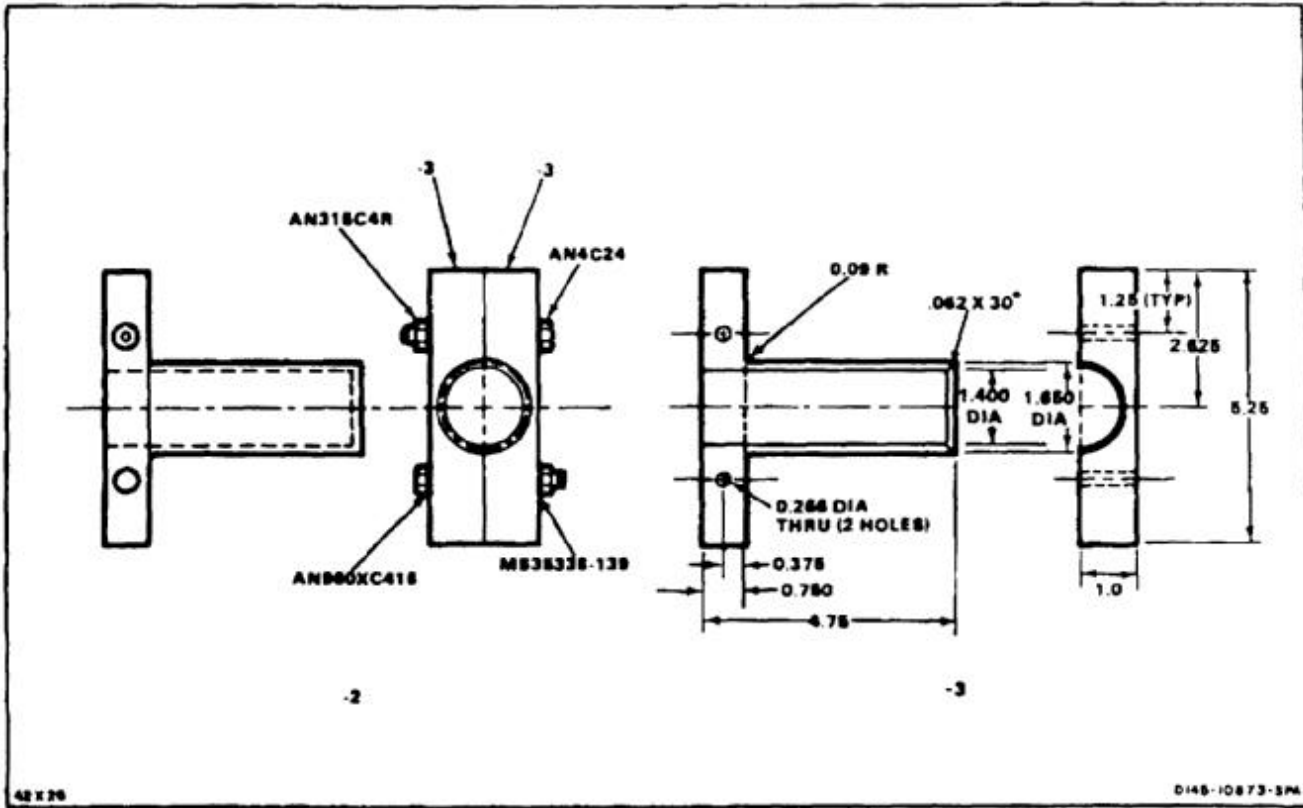

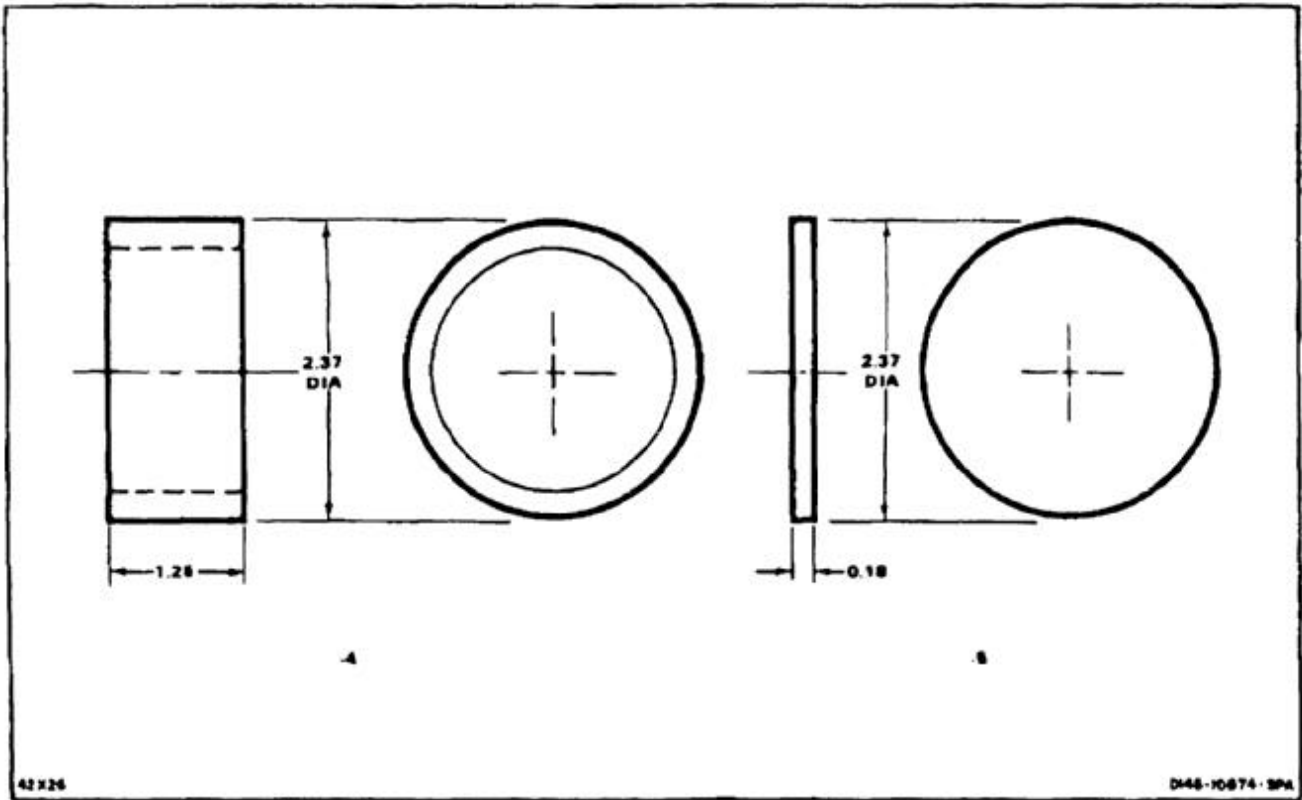

Sheet 3 of 3

END OF TASK

NOTES:

1. FABRICATE FROM STEEL, CRES, TYPE 304.
2. ALL DIMENSIONS IN INCHES.

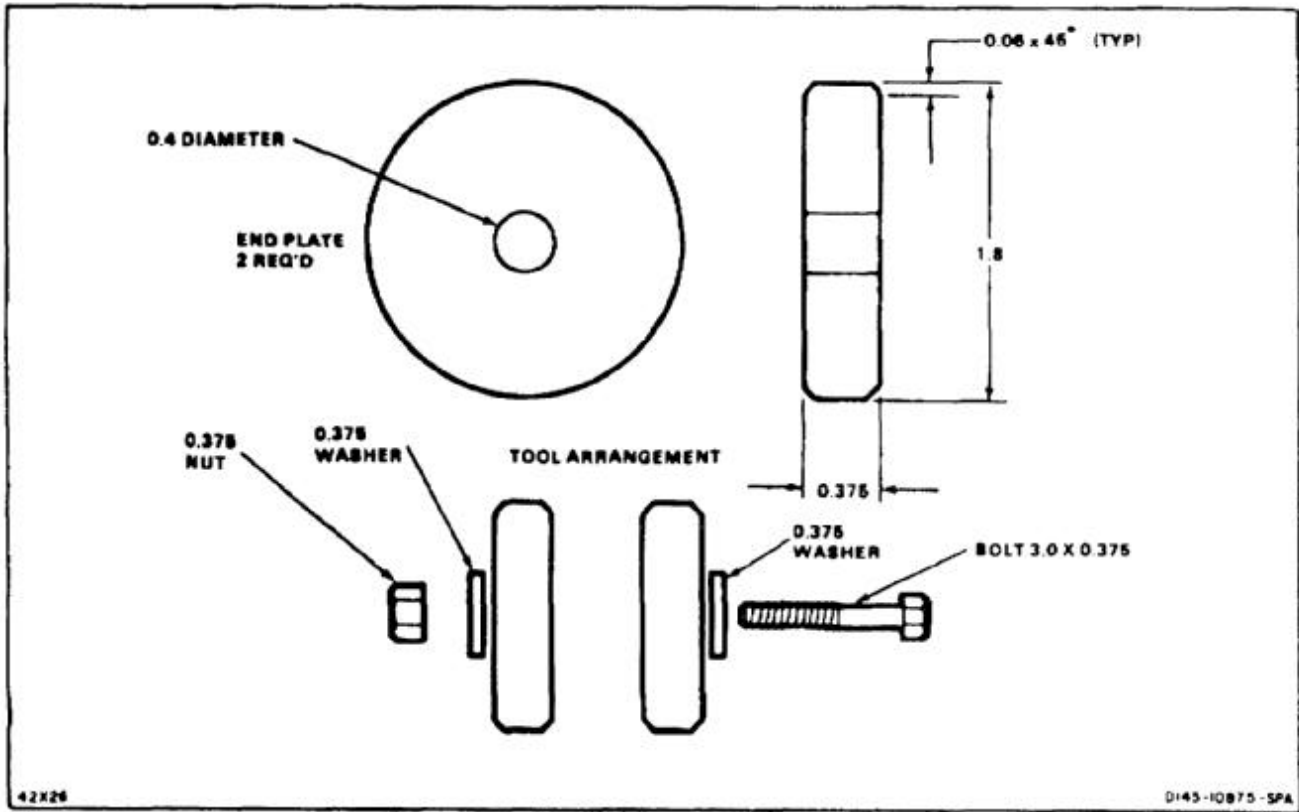

END OF TASK

NOTES:

1. FABRICATE FROM NSN 9530-00-492-3755.
2. ALL DIMENSIONS IN INCHES.

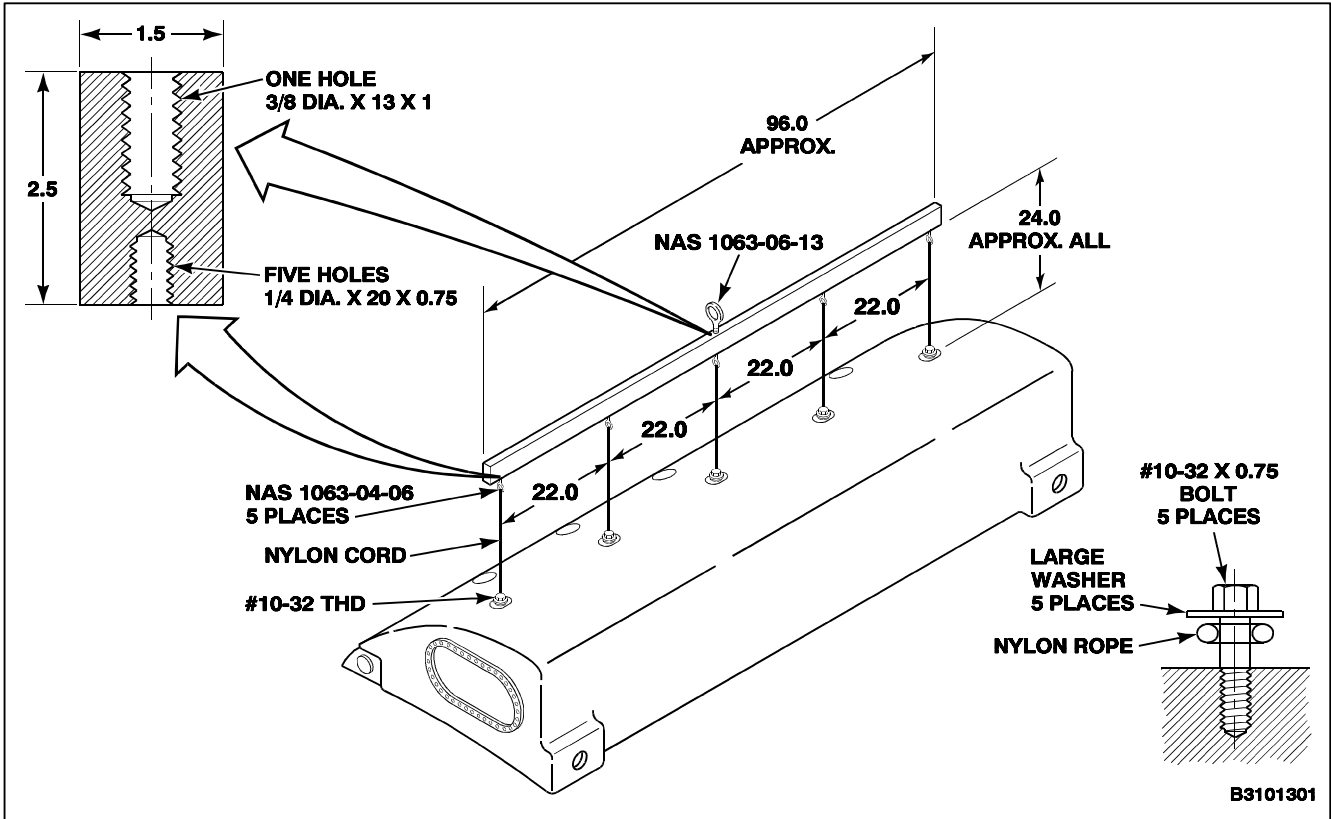

END OF TASK

NOTES:

1. FABRICATE FROM QQ-A-250-5,
NSN 9535-00-084-4551.
2. ALL DIMENSIONS IN INCHES.

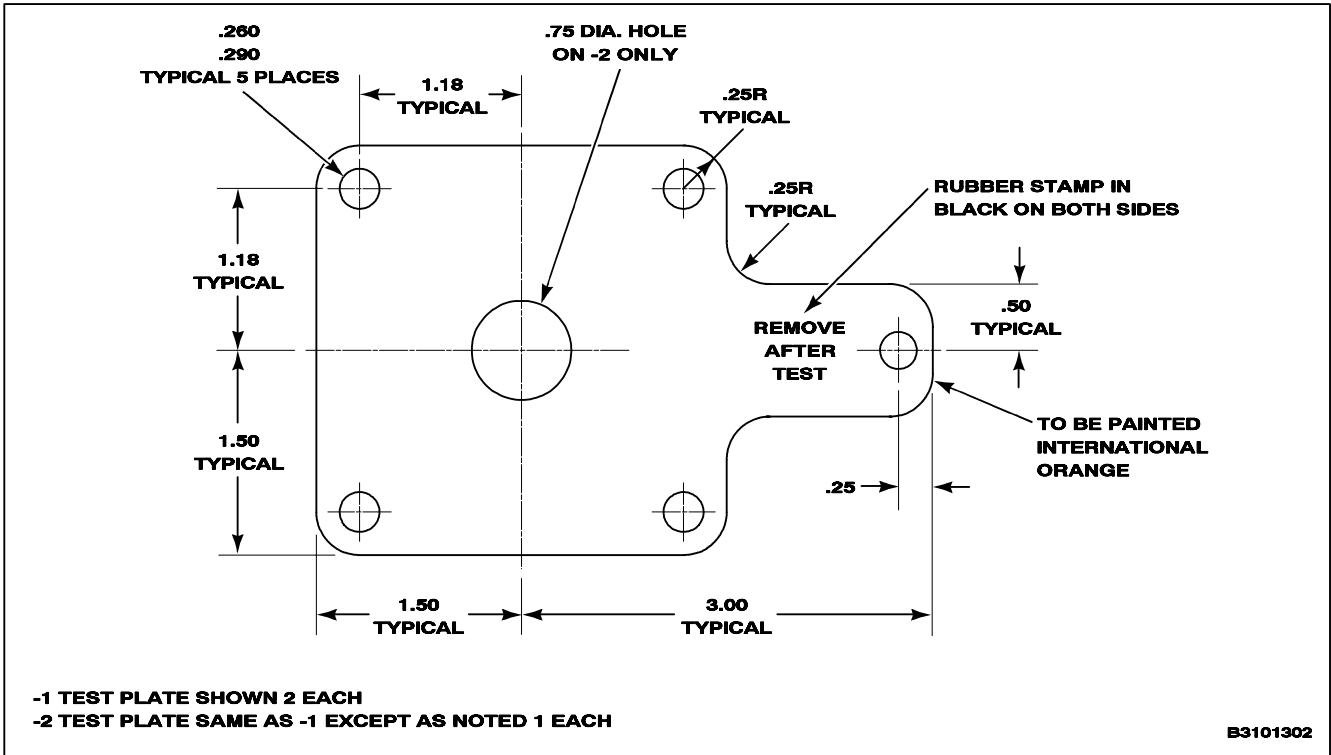

NOTES:

1. FABRICATE FROM WIRE ROPE 0.375 DIAMETER X 24.0, NSN 4010-00-270-5494.
2. USE WIRE ROPE SWAGING SLEEVES MS51844-70.

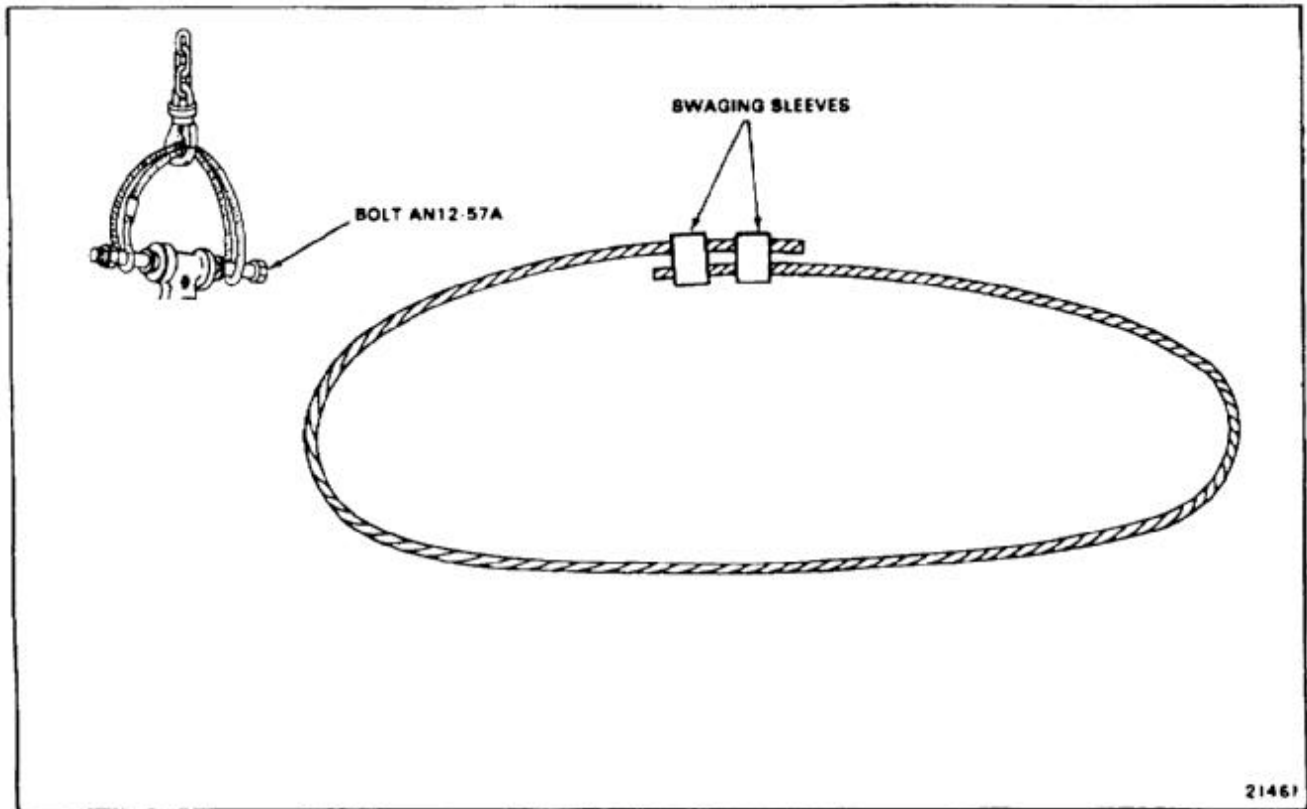

END OF TASK

E-19 BRAKE MASTER CYLINDER TEST STAND**E-19**

4	-3	-2	-1	DASH NO.	NOMENCLATURE	MATERIAL	NSN
				1	WEIGHT, 25 POUNDS	CRS, CYLINDRICAL	
				1	WEIGHT, 50 POUNDS	CRS, CYLINDRICAL	
				1	WEIGHT, 94 POUNDS	CRS, CYLINDRICAL	
				1	WEIGHT, 160 POUNDS	CRS, CYLINDRICAL	
			1		CARR LANE CL-9-LP	L PIN	5315-00-547-3809
1	1				CARR LANE CL-5-LP	L PIN	5315-00-075-7845
			3		CARR LANE CL-2-C-9.0	NYLON CABLE	4018-00-069-5180
			6		CARR LANE CL-2-F	FERRULE	4030-01-219-8678
2					ACE OR EQUIV. 2500-P-26-5	HEADLESS P.F. BUSHING	3120-00-598-8720
			1		MS35425-74	WING NUT	5310-01-088-2490
		4			MS27039-4-12	PAN HD. SCREW	5305-00-891-1784
1					AN315-6	SELF-LOCKING NUT	5310-00-843-4824
		4			AN960-616	FLAT WASHER	5310-01-016-4871
1					AN960-416	FLAT WASHER	5310-00-141-1795
		4			AN6-10A	HEX HD. BOLT	5306-00-208-3636
			1		AN526-1032R7	TRUSS HD. MACH. SCREW	5305-00-272-4951
1					AN4-17A	HEX HD. BOLT	5306-00-151-1417
1		-15			HOOK	CRS 3/8 DIA. X 8.1	9510-00-607-1491
1		-14			BRACKET	CRS 1 X 1-1/4 X 2.8	9510-00-481-0671
1		-13			ARM	2024-T351 1 X 1-1/2 X 59.3	
	2	-12			BUSHING	CRS 1.0 DIA. X.5	9510-00-975-2640
	2	-11			SPACER	2024-T3.190 X 1.2 X 1.5	
	2	-10			LUG	6061-T651 1/2 X 1.4 X 1.4	
	1	-9			BASE	6061-T651 1/2 X 1.4 X 6.0	
	1	-8			RETAINER	CRS 3/8-16 UNC X 18.0	9510-00-607-1491
	1	-7			COLUMN	CRS 1-1/2 X 3 X 18-1/2	
	2	6			PAD	2024-T351 ALUM BAR 1/2 X 2 X 6	
	1	-5			BASE	CRS 1/2 x 6 x 18.0	9510-00-001-3315
	1	-4			ARM ASSY		
	1	-3			LOWER BRACKET ASSY		
	1	-2			BASE ASSY		
		-1			TEST STAND ASSY		

NOTE

ALL DIMENSIONS IN INCHES

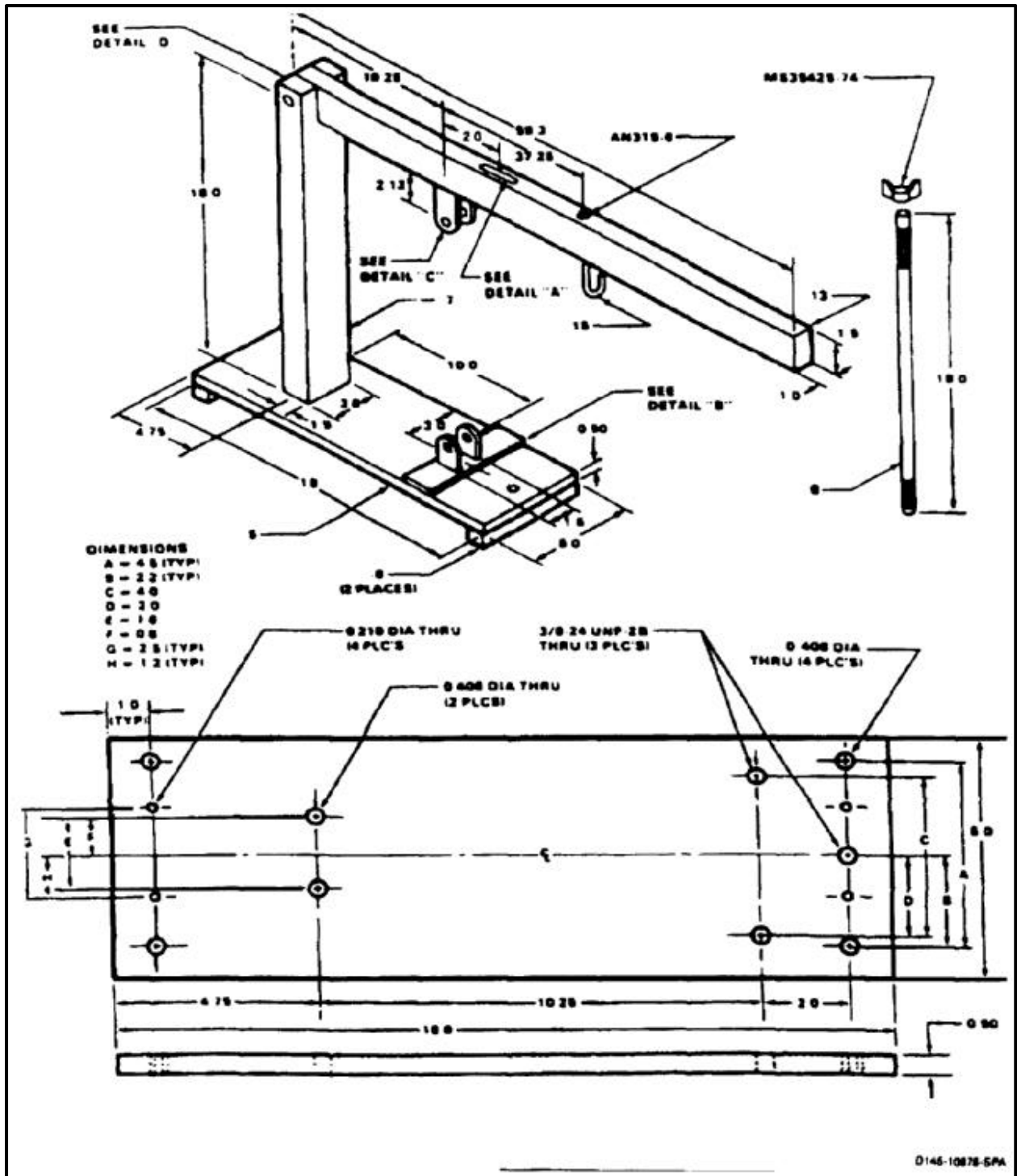

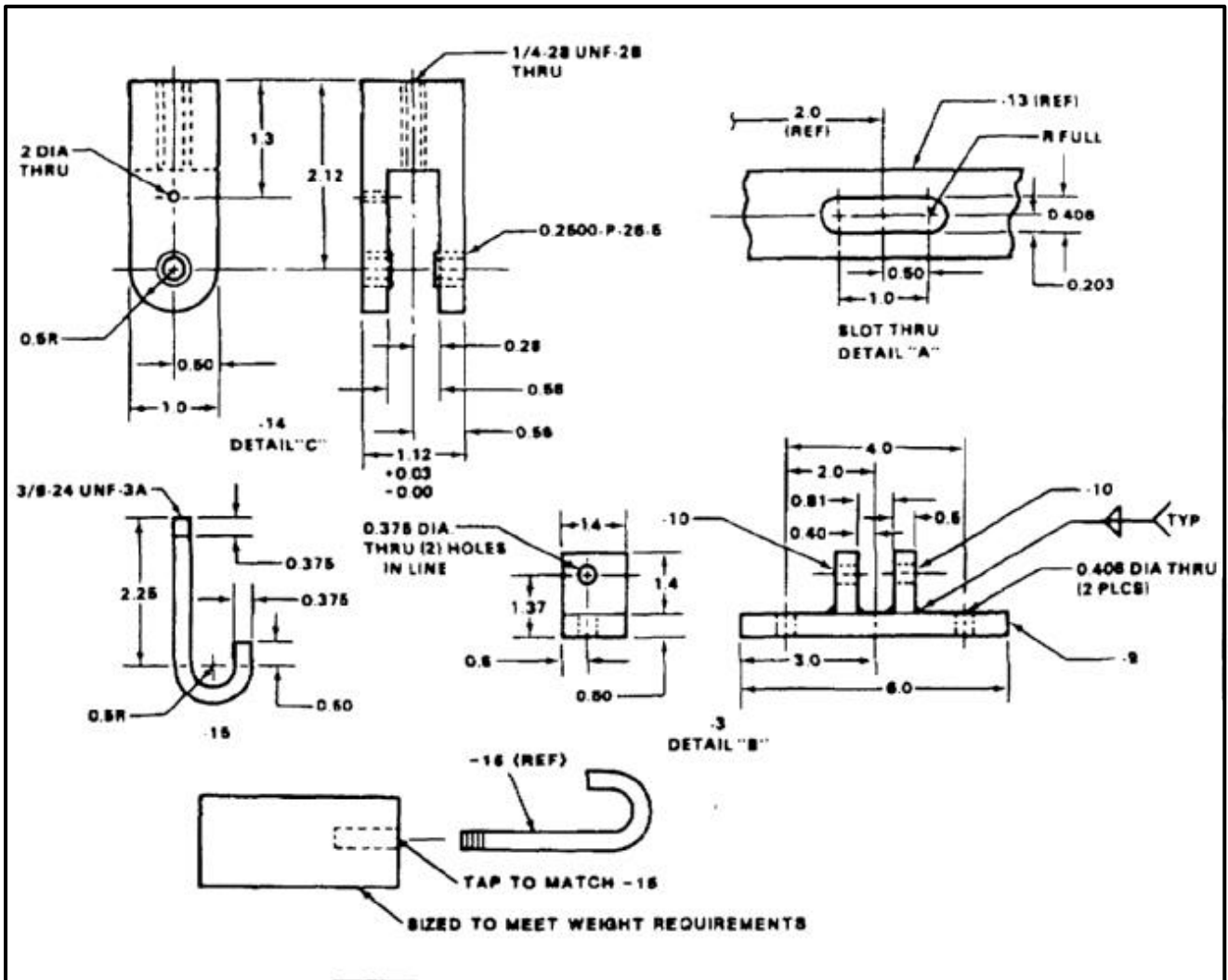

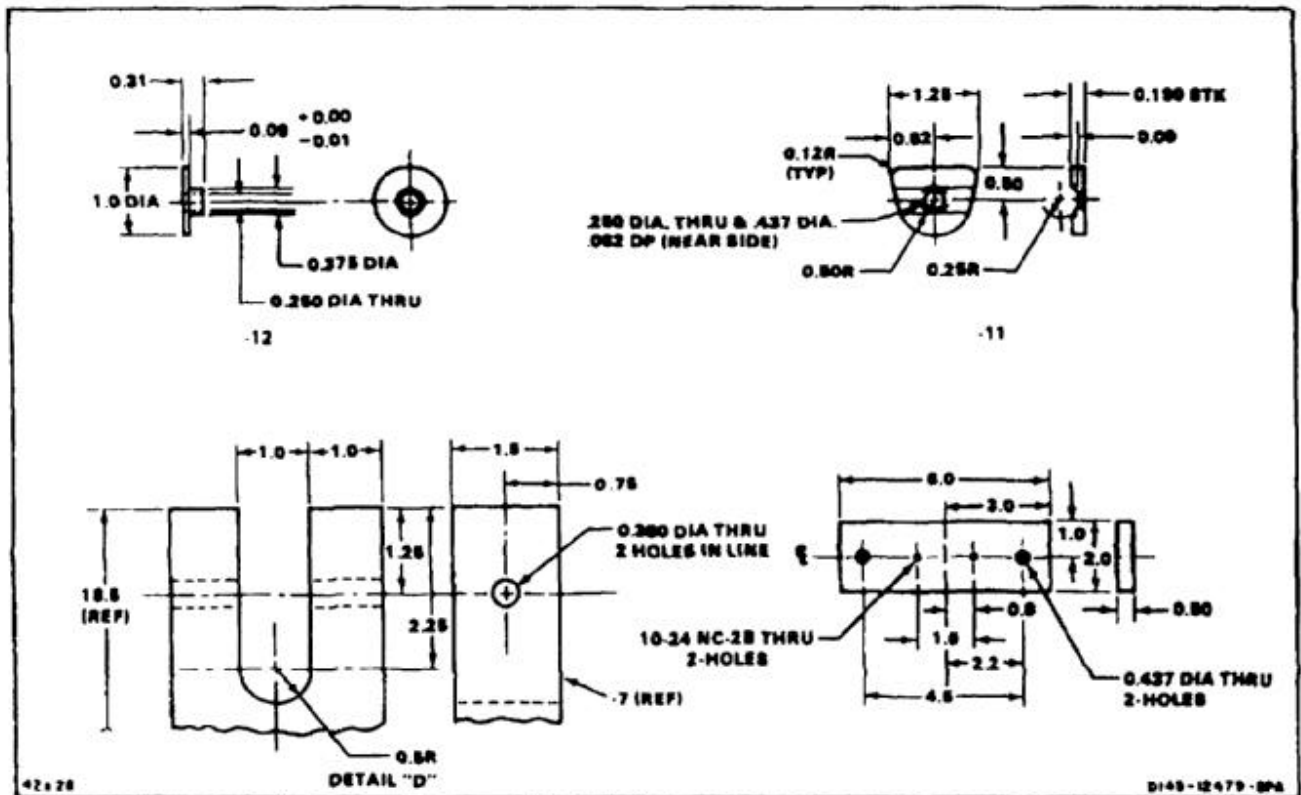

NOTES:

1. FABRICATE FROM METAL PLATE
NSN 9515-00-234-7944.
2. ALL DIMENSIONS IN INCHES ± 0.02 .
3. CUT STOCK TO SIZE 10.00 X 8.00 X 0.25.
4. BREAK SHARP EDGES.

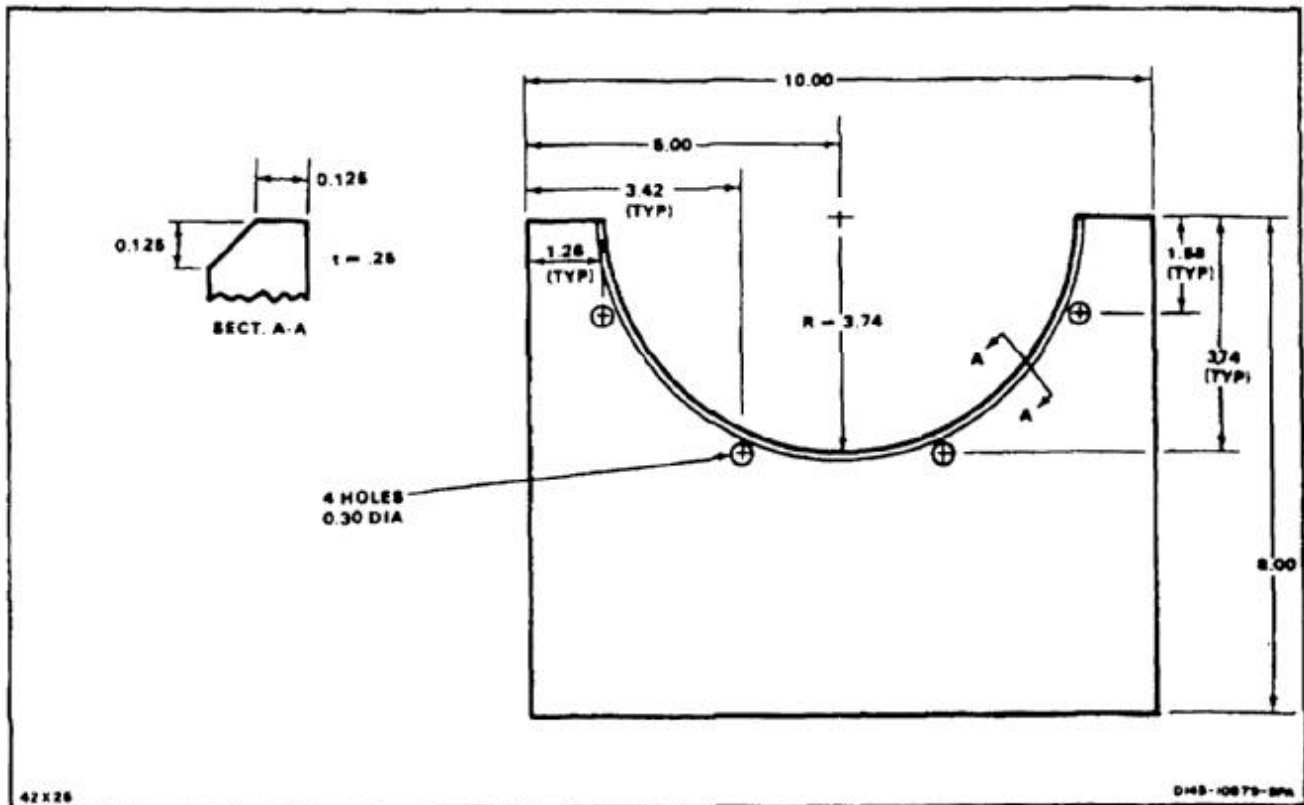

END OF TASK

NOTES:

1. FABRICATE FROM METAL PLATE, 4340 STEEL, NSN 9515-00-901-4241.
2. ALL DIMENSIONS IN INCHES.
3. TOLERANCES:
 .X = $\pm .1$
 .XX = $\pm .03$
 .XXX = $.010$
4. BREAK SHARP EDGES.

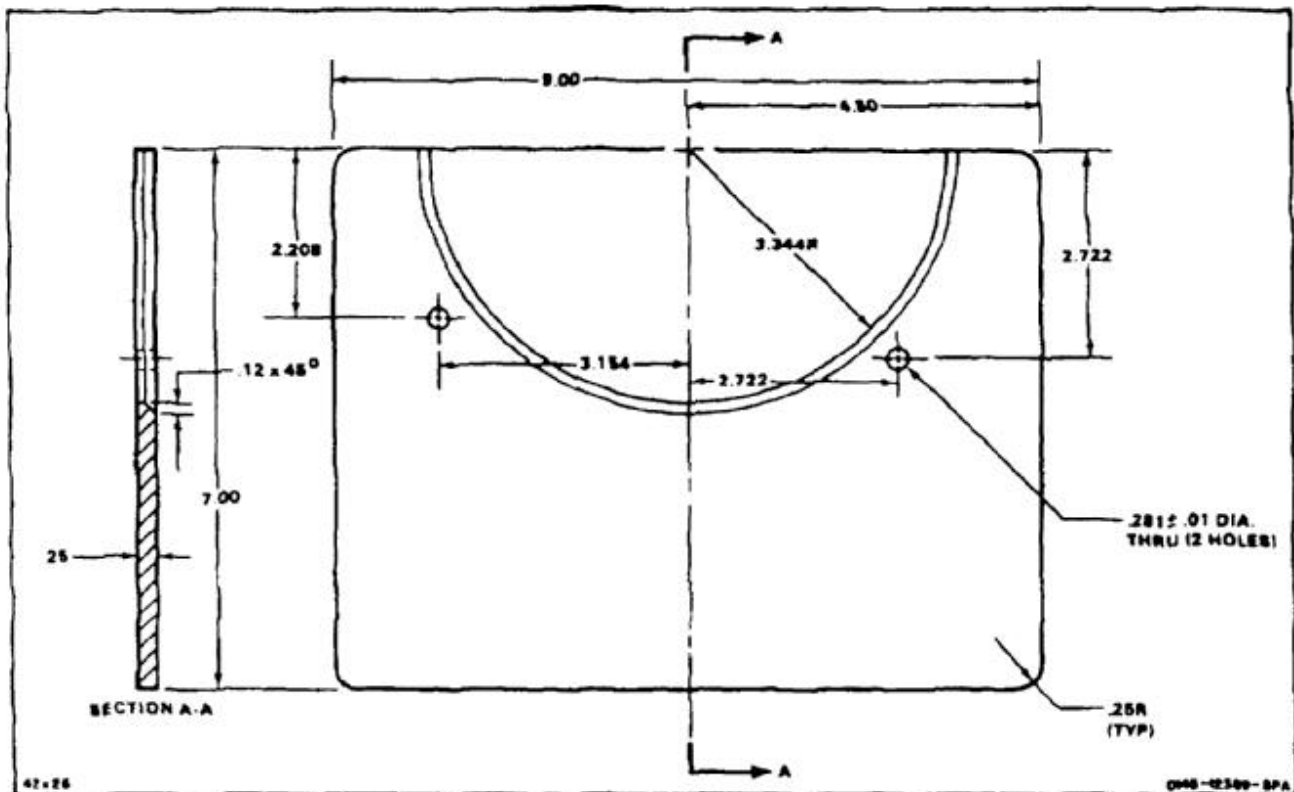

END OF TASK

NOTES:

1. FABRICATE FROM METAL PLATE, 4340 STEEL, NSN 9515-00-901-4241.
2. ALL DIMENSIONS IN INCHES.
3. TOLERANCES:
 .X = $\pm .1$
 .XX = $\pm .03$
 .XXX = $\pm .010$
4. BREAK SHARP EDGES.

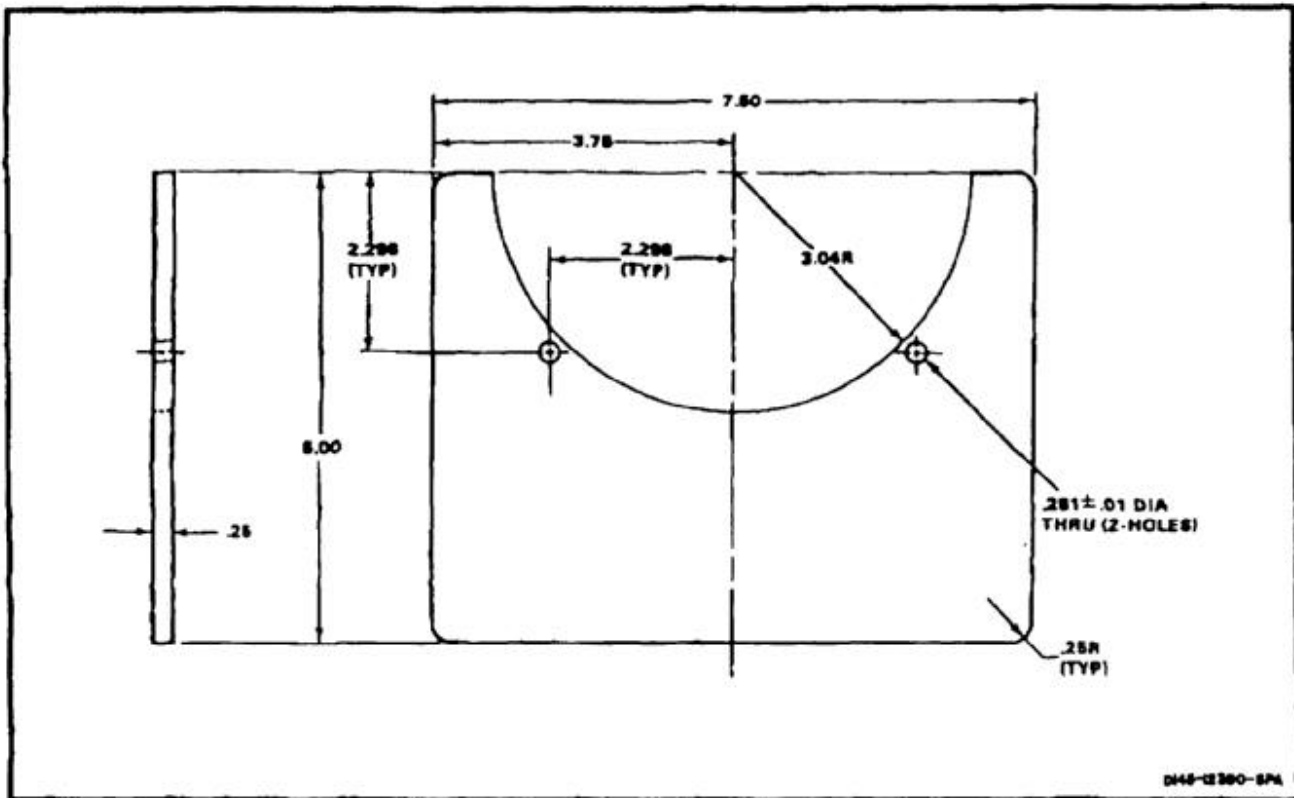

Task E-23 Deleted.

END OF TASK

NOTES:

1. FABRICATE FROM STEEL TUBING ONLY.
2. ALL DIMENSIONS IN INCHES.
3. BREAK SHARP EDGES AND REMOVE BURRS.
4. TUBE STOCK I.D. TO BE MEASURED.
MACHINING NOT REQUIRED IF WITHIN
SPECIFIED TOLERANCE.

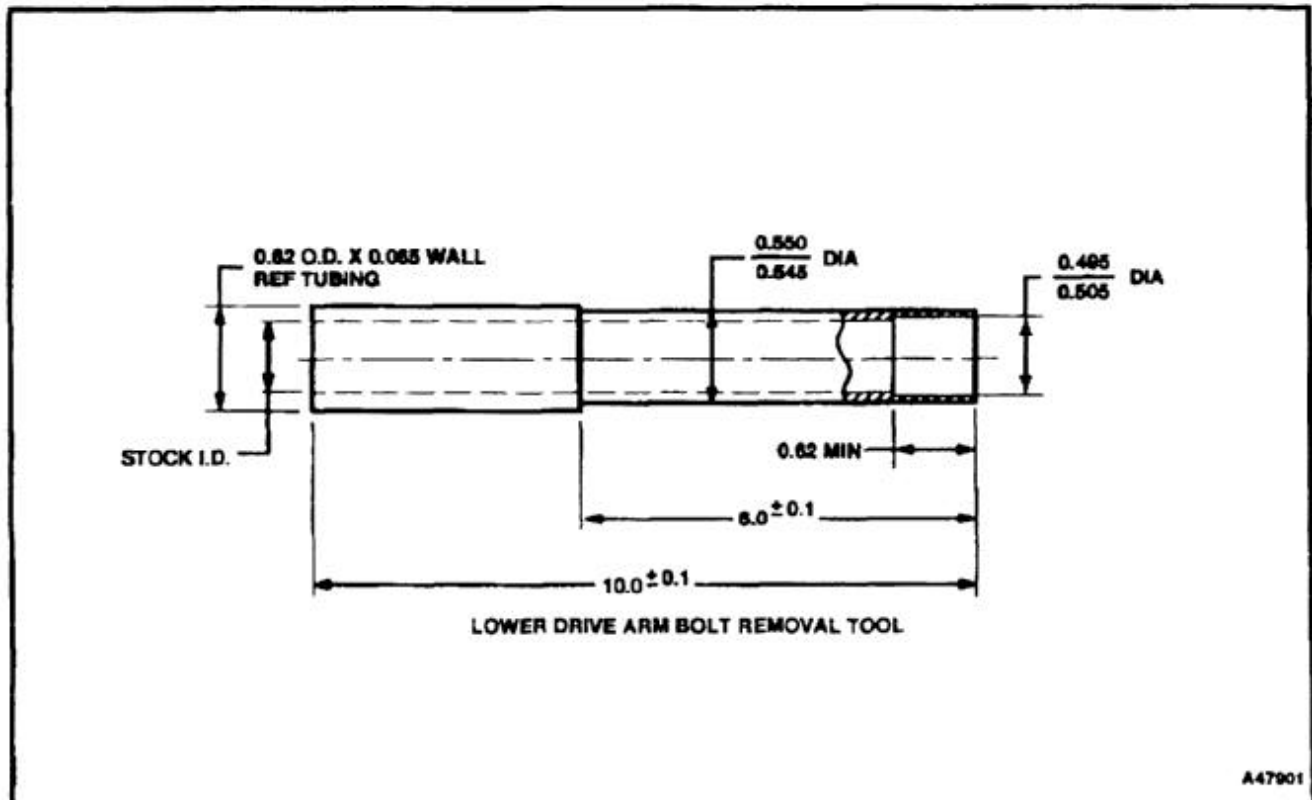

END OF TASK

NOTES:

1. FABRICATE FROM STEEL TUBING ONLY.
2. ALL DIMENSIONS IN INCHES.
3. BREAK SHARP EDGES AND REMOVE BURRS.
4. TUBE STOCK I.D. TO BE MEASURED.
MACHINING NOT REQUIRED IF WITHIN SPECIFIED TOLERANCE.

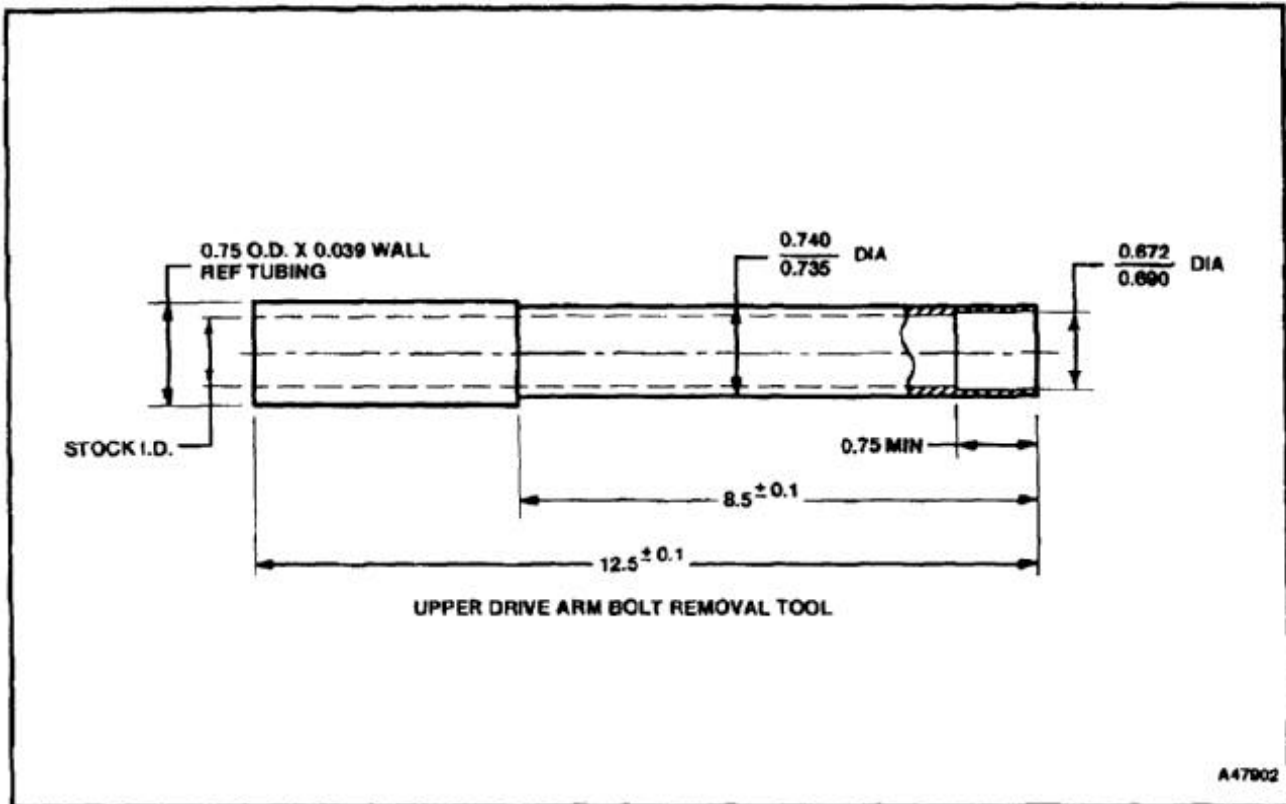

END OF TASK

NOTES:

1. ALL DIMENSIONS IN INCHES.
2. FABRICATE FROM 2024-T3 ALUMINUM ALLOY CLAD SHT PER QQ-A-250/5.
3. STOCK SIZE -2: 0.020 X 0.70 X 29.2
STOCK SIZE -16: 0.020 X 0.70 X 12.2.
4. FINISH AS REQUIRED.

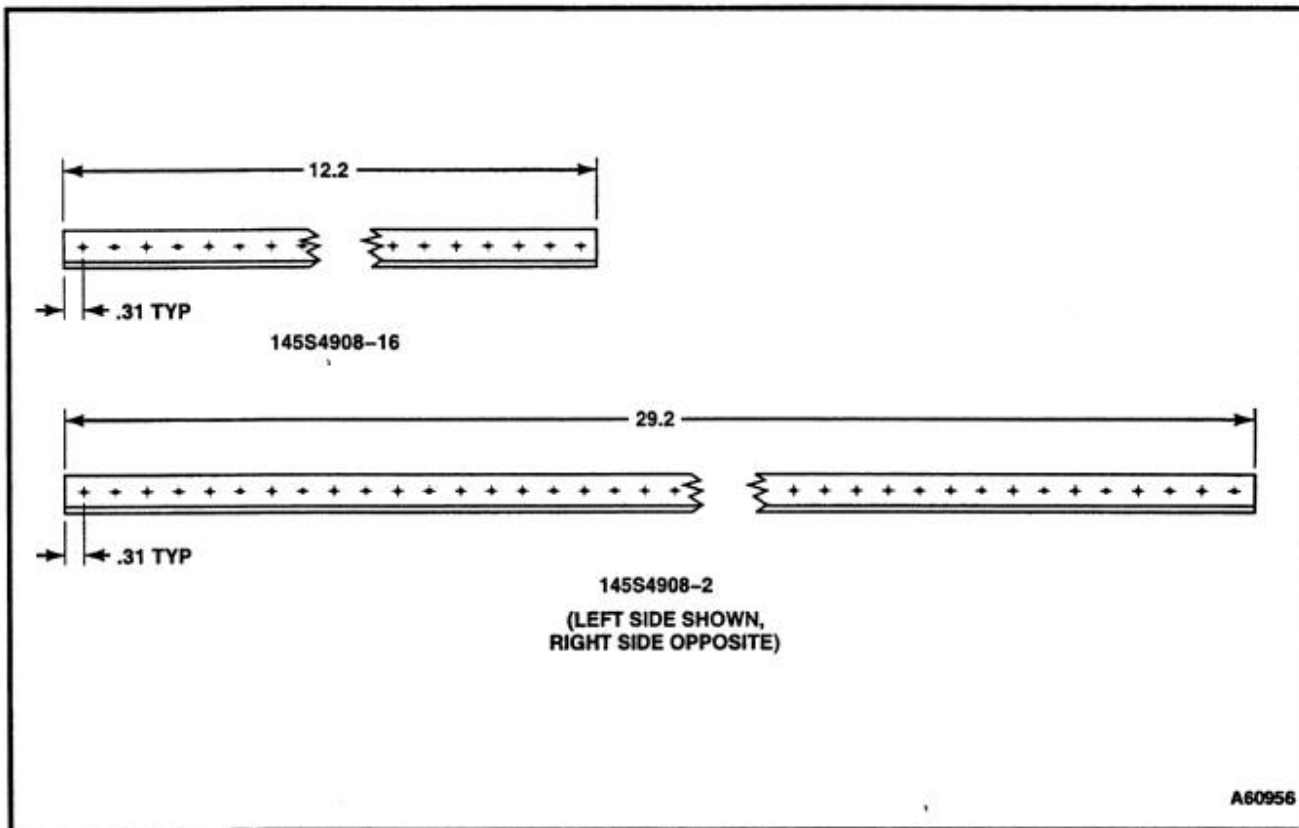

END OF TASK

NOTES:

1. FABRICATE FROM METAL PLATE, AL ALLOY 6061, MINIMUM THICKNESS .040 INCH, NSN 9535-00-314-6903
2. ALL DIMENSIONS IN INCHES.
3. TOLERANCES:
.X = $\pm .1$
.XX = $\pm .03$
.XXX = $.010$
4. BREAK SHARP EDGES EXCEPT SCRAPING EDGE.

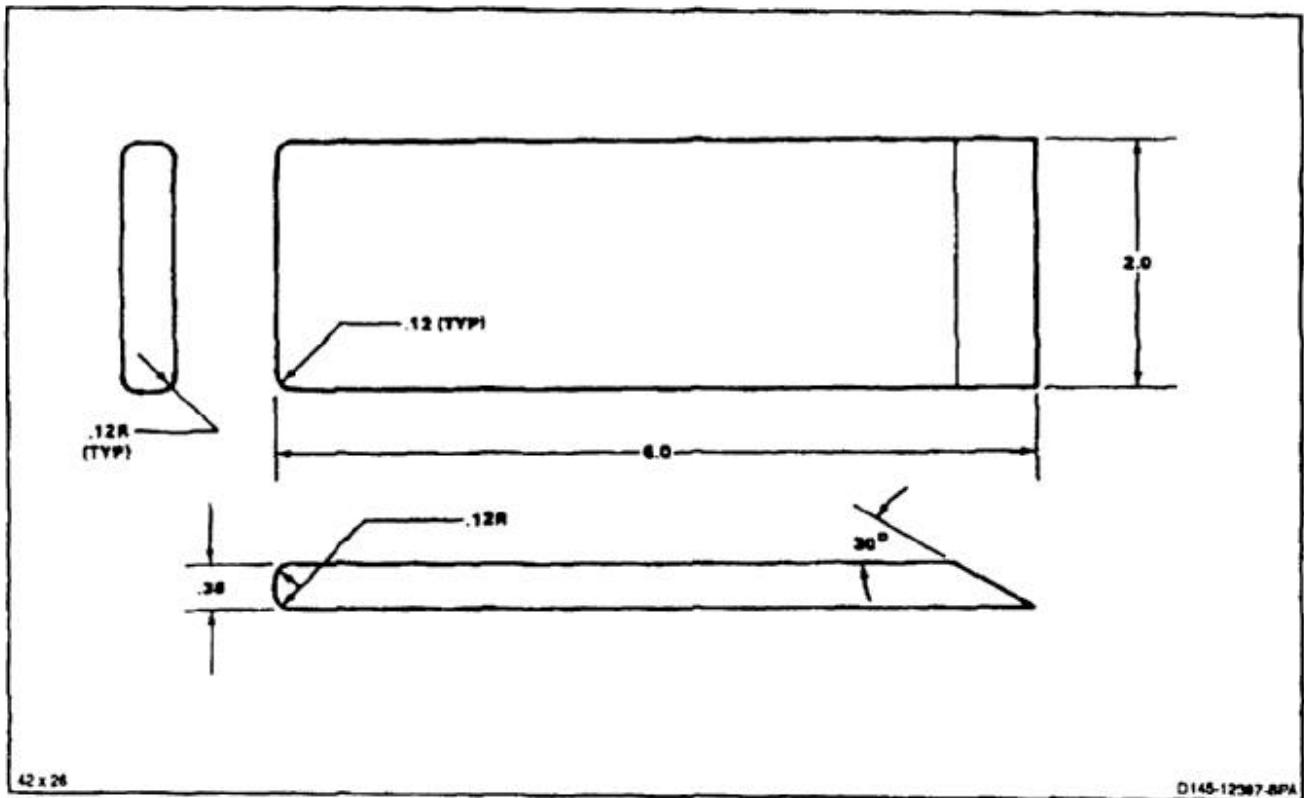

END OF TASK

NOTES:

1. ALL DIMENSIONS IN INCHES.
2. TOLERANCES:
 .X = ±.1
 .XX = ±.02
 .XXX = ±.010

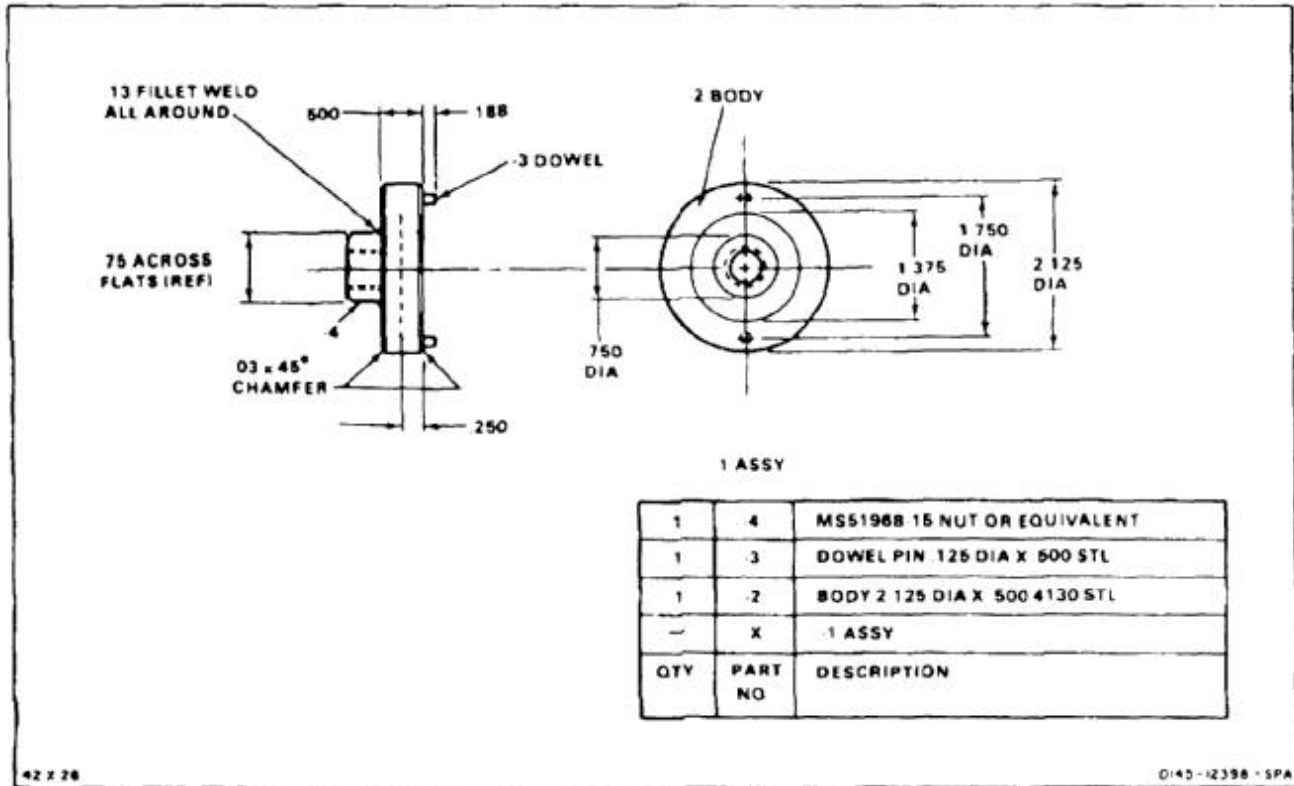

END OF TASK

NOTES:

1. FABRICATE FROM 4140 STEEL.
2. ALL DIMENSIONS IN INCHES.
3. TOLERANCES:
 .X = $\pm .1$
 .XX = $\pm .03$
 .XXX = $\pm .010$
4. BREAK SHARP EDGES.

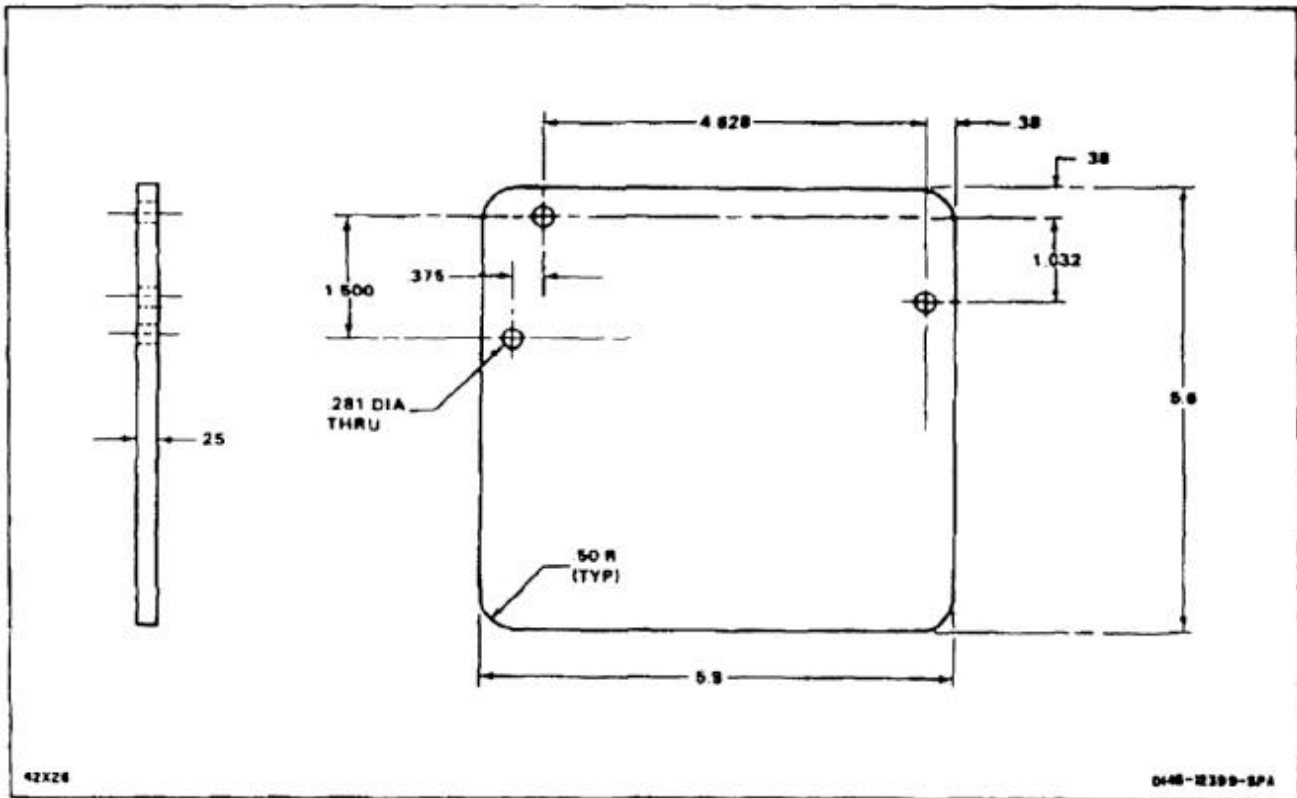

END OF TASK

NOTES:

1. ALL DIMENSIONS IN INCHES.
2. TOLERANCES:
 .X = ±.1
 .XX = ±.03
 .XXX = ±.010
3. BREAK SHARP EDGES.

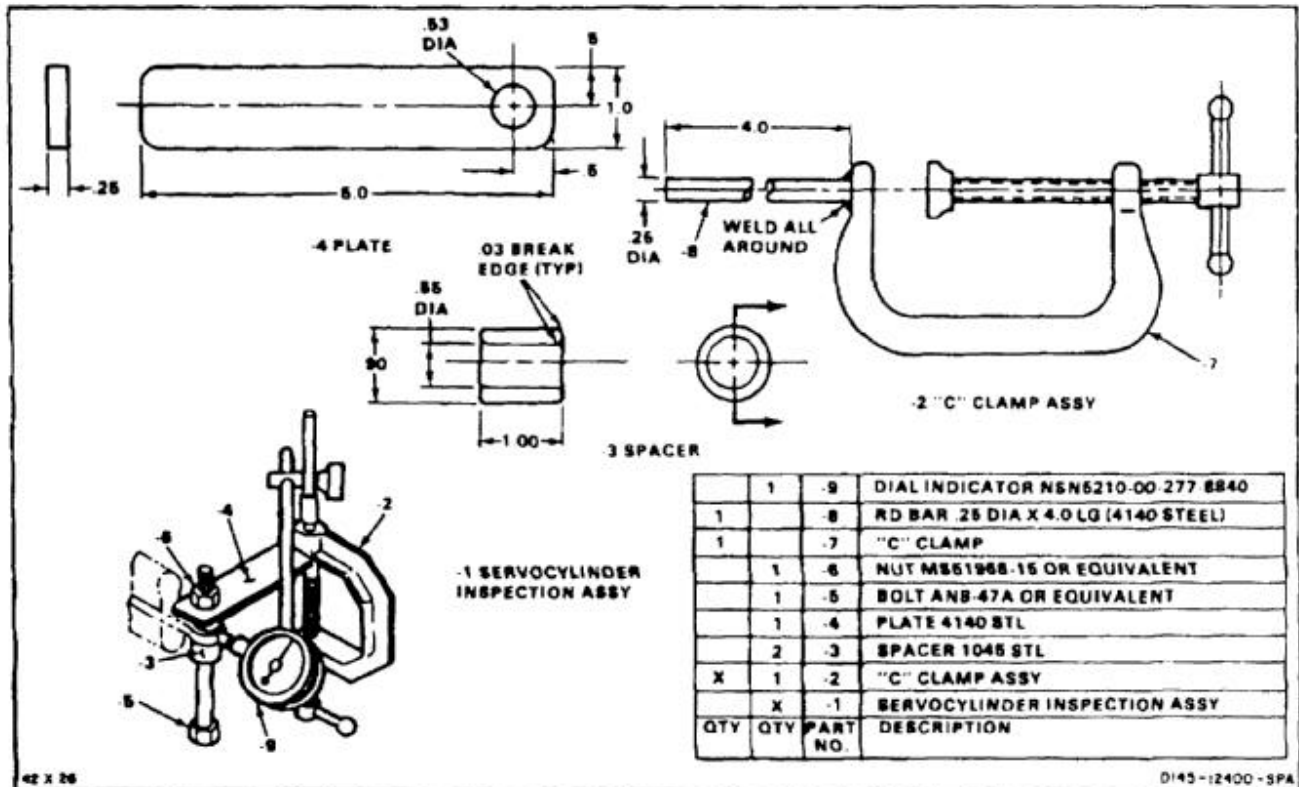

END OF TASK

NOTES:

1. FABRICATE FROM 4140 STEEL.
2. ALL DIMENSIONS IN INCHES.
3. TOLERANCES:
 .X = $\pm .1$
 .XX = $\pm .03$
 .XXX = $\pm .010$
4. BREAK SHARP EDGES.

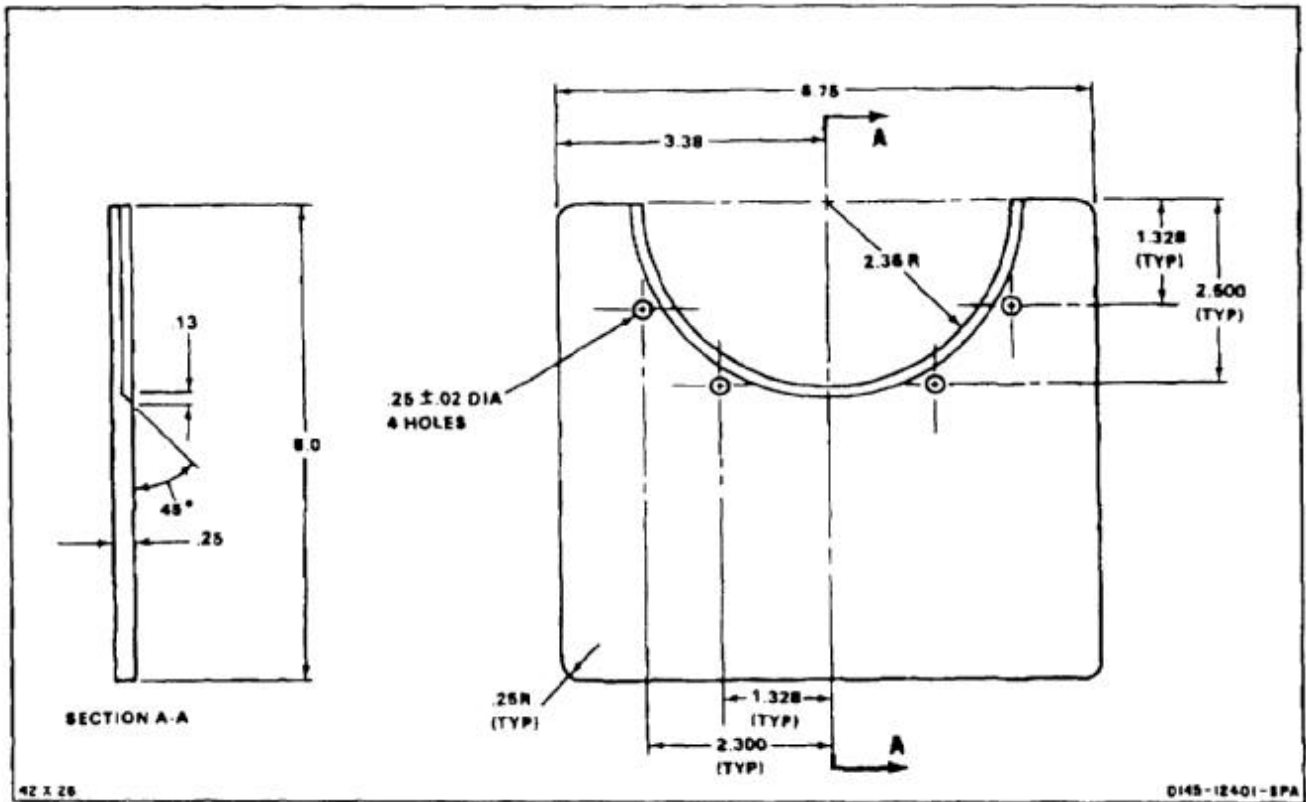

END OF TASK

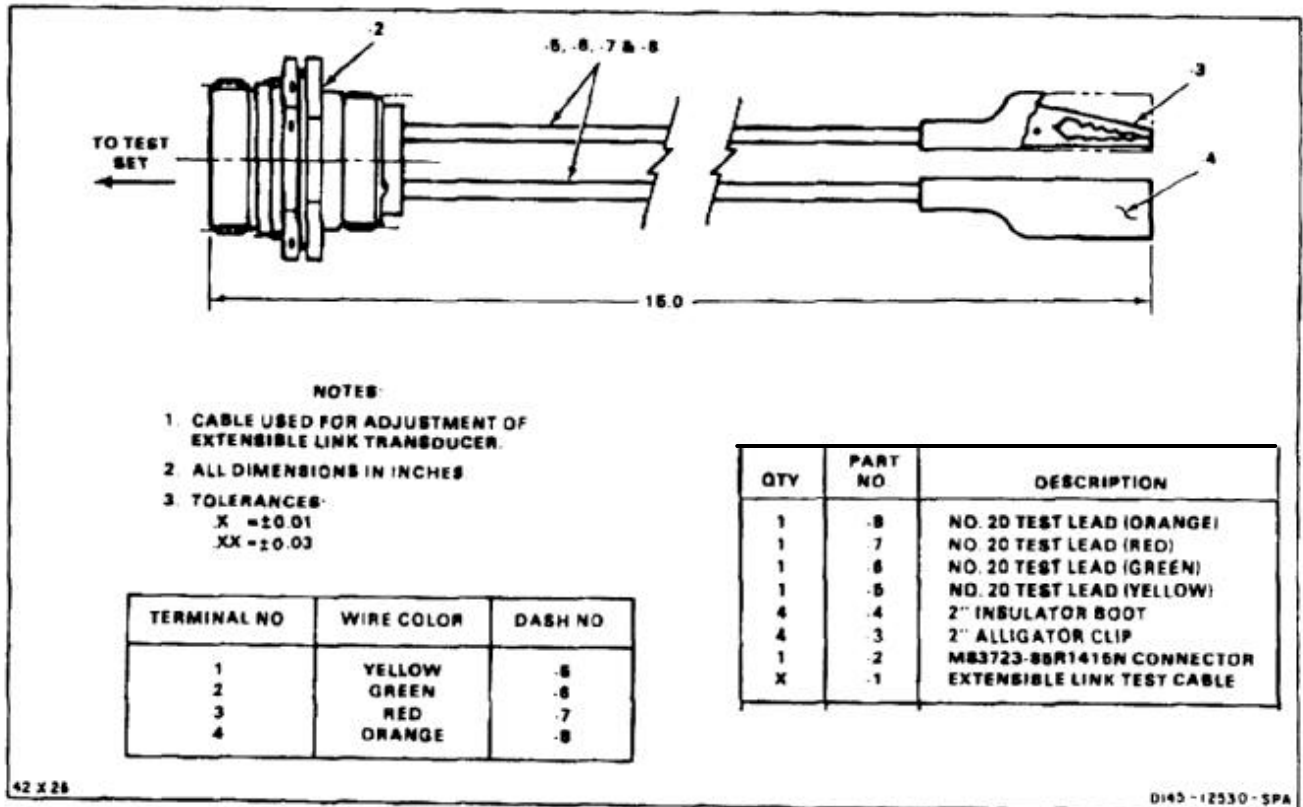

NOTES:

1. FABRICATE FROM 4140 STEEL SHT.
2. STOCK SIZE 0.125 X 1.0 X 8.0.
3. ALL DIMENSIONS IN INCHES.
4. TOLERANCES:
.X = $\pm .1$
.XX = $\pm .03$
.XXX = $\pm .010$
5. BREAK SHARP EDGES.

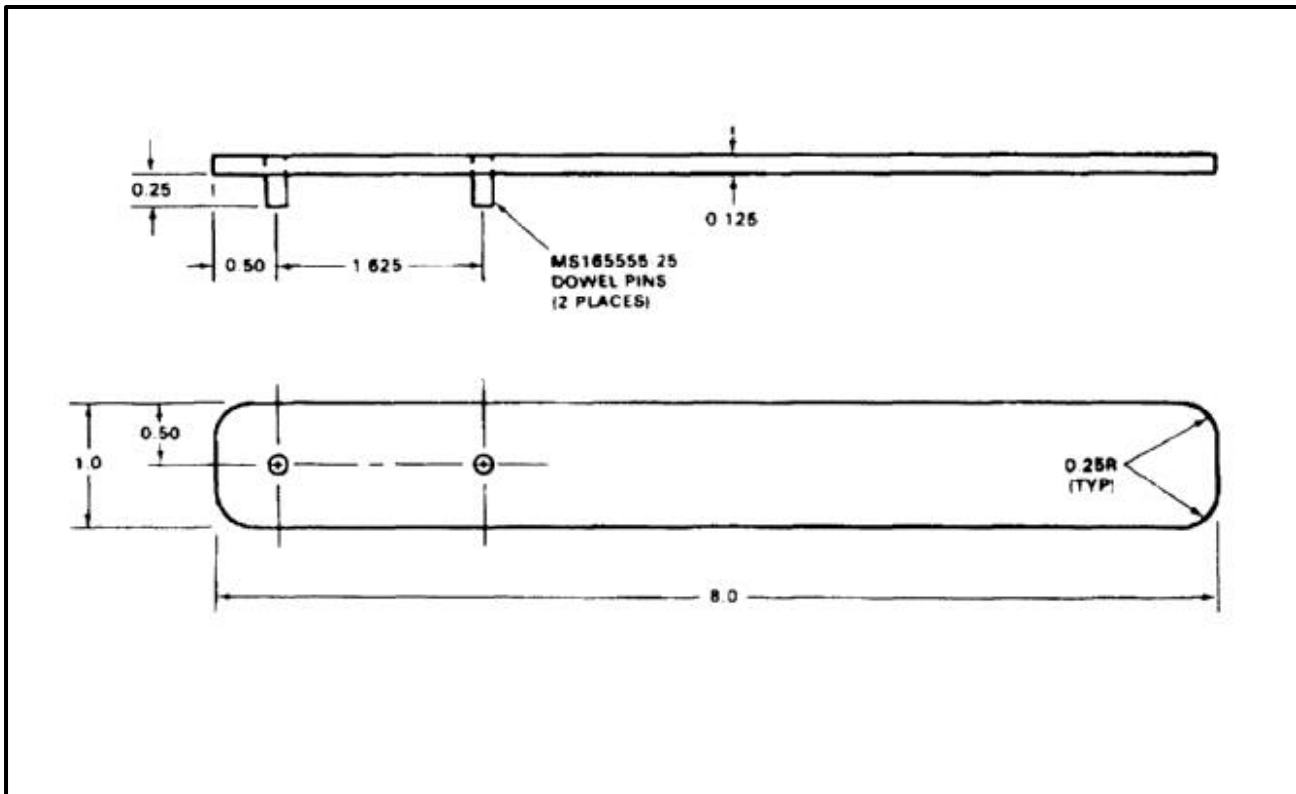

END OF TASK

NOTES:

PITOT STATIC TESTER HOSE CONNECTOR USED FOR AFCS BENCH TEST OF COMPUTER.

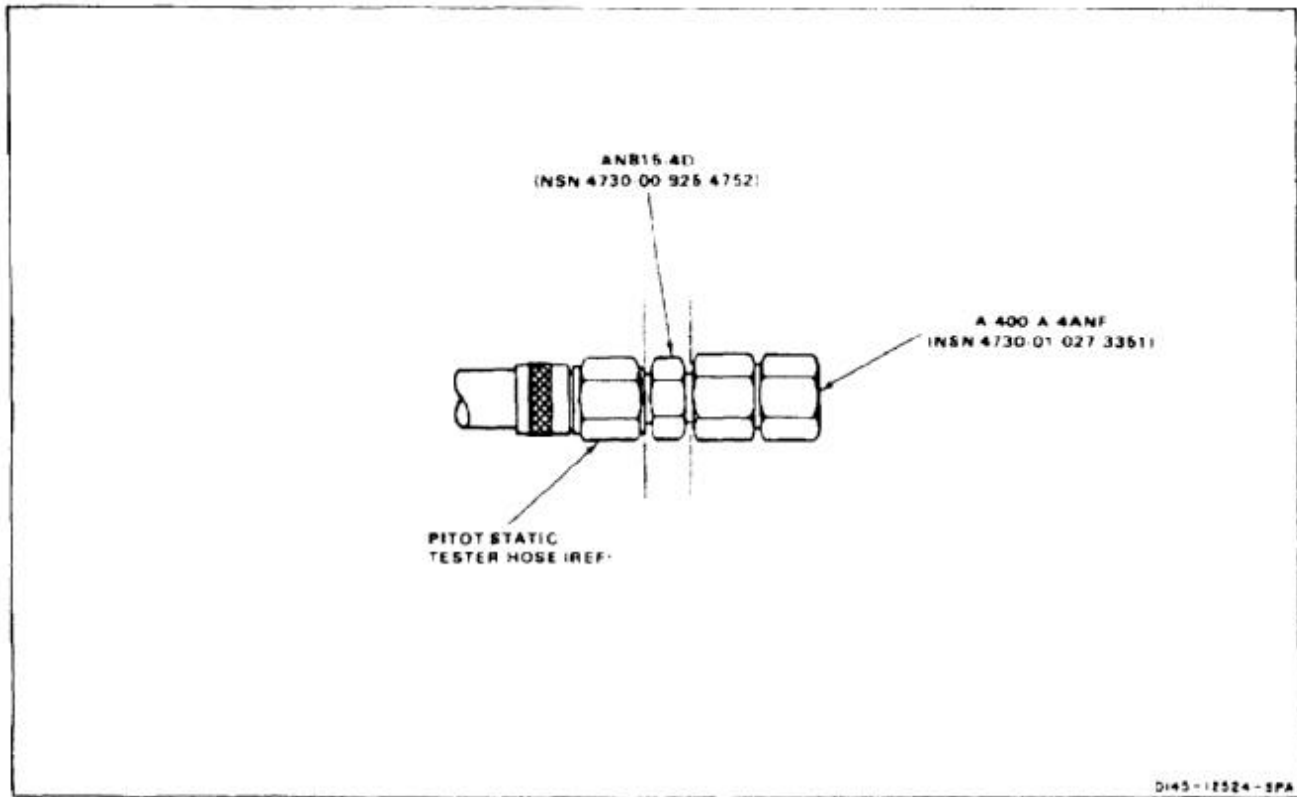

END OF TASK

NOTES:

PITOT STATIC TESTER HOSE CONNECTOR USED FOR AFCS BENCH TEST OF COMPUTER.

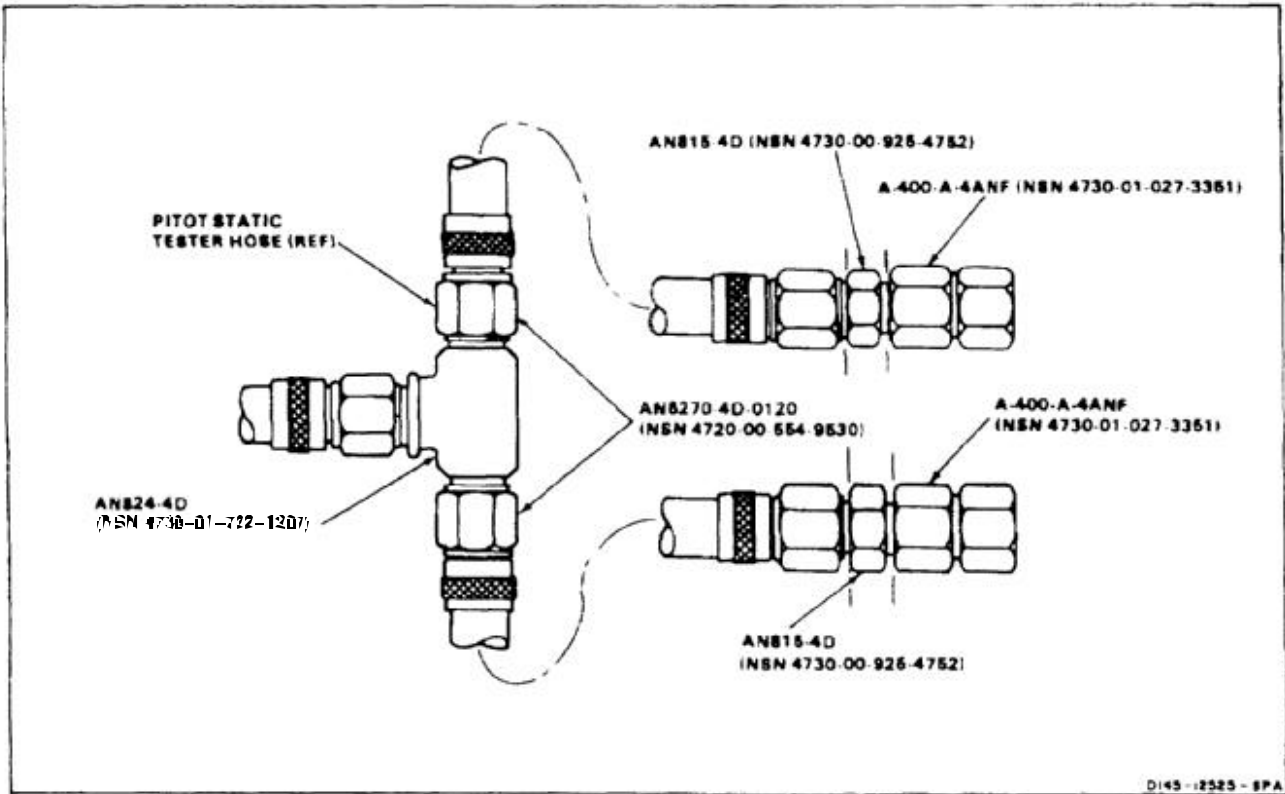

E-38 COCKPIT TRANSFER BELLCRANK SHAFT PULLER

E-38

NOTES:

1. ALL DIMENSIONS IN INCHES.
2. TOLERANCES:
 .X = ±.1
 .XX = ±.03
 .XXX = ±.010

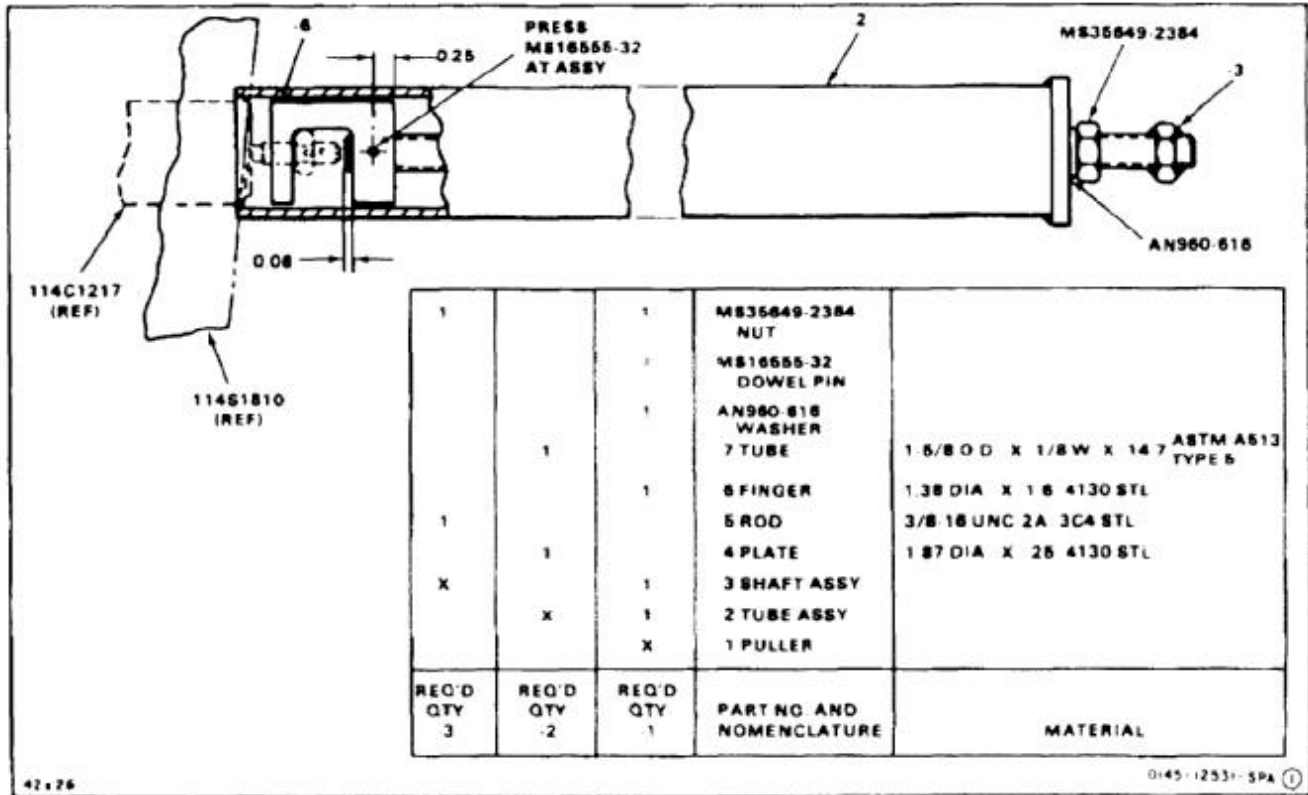

42-26

0145-12531-5PA ①

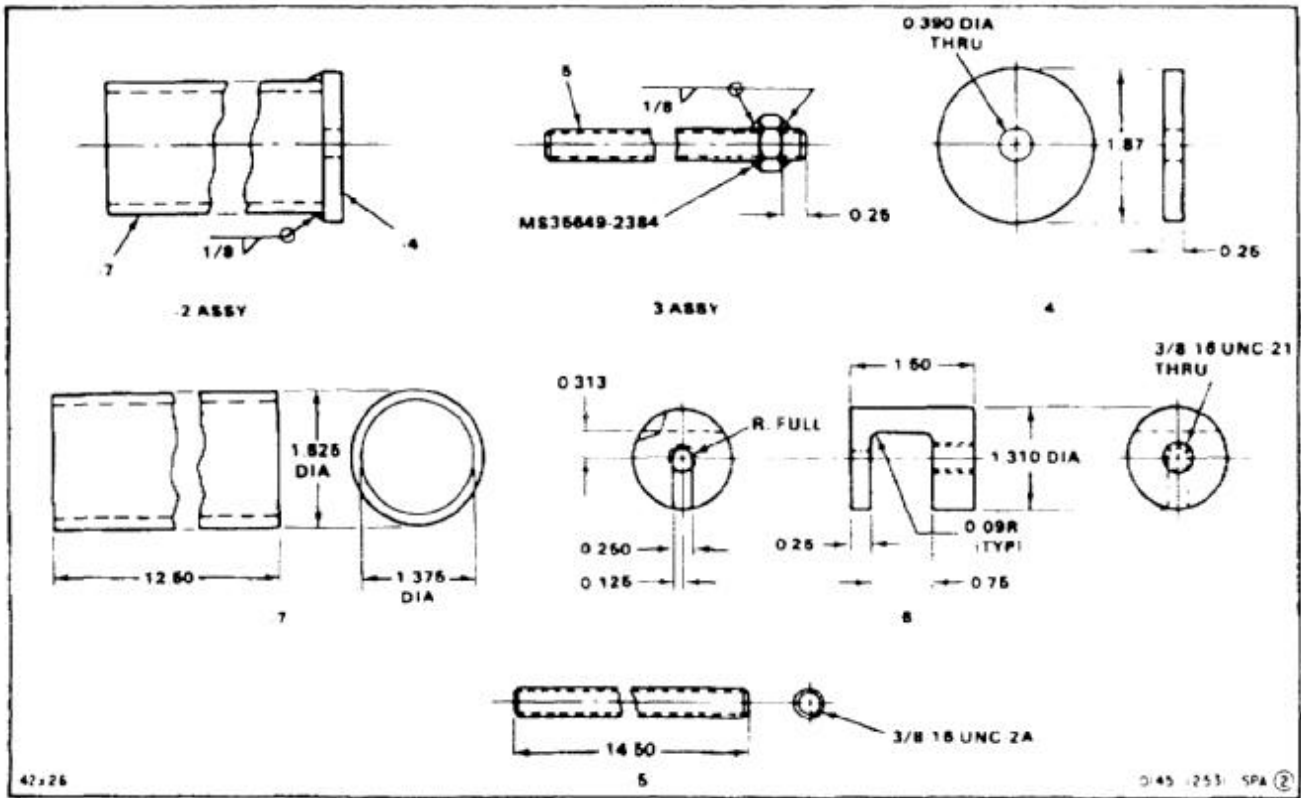

END OF TASK

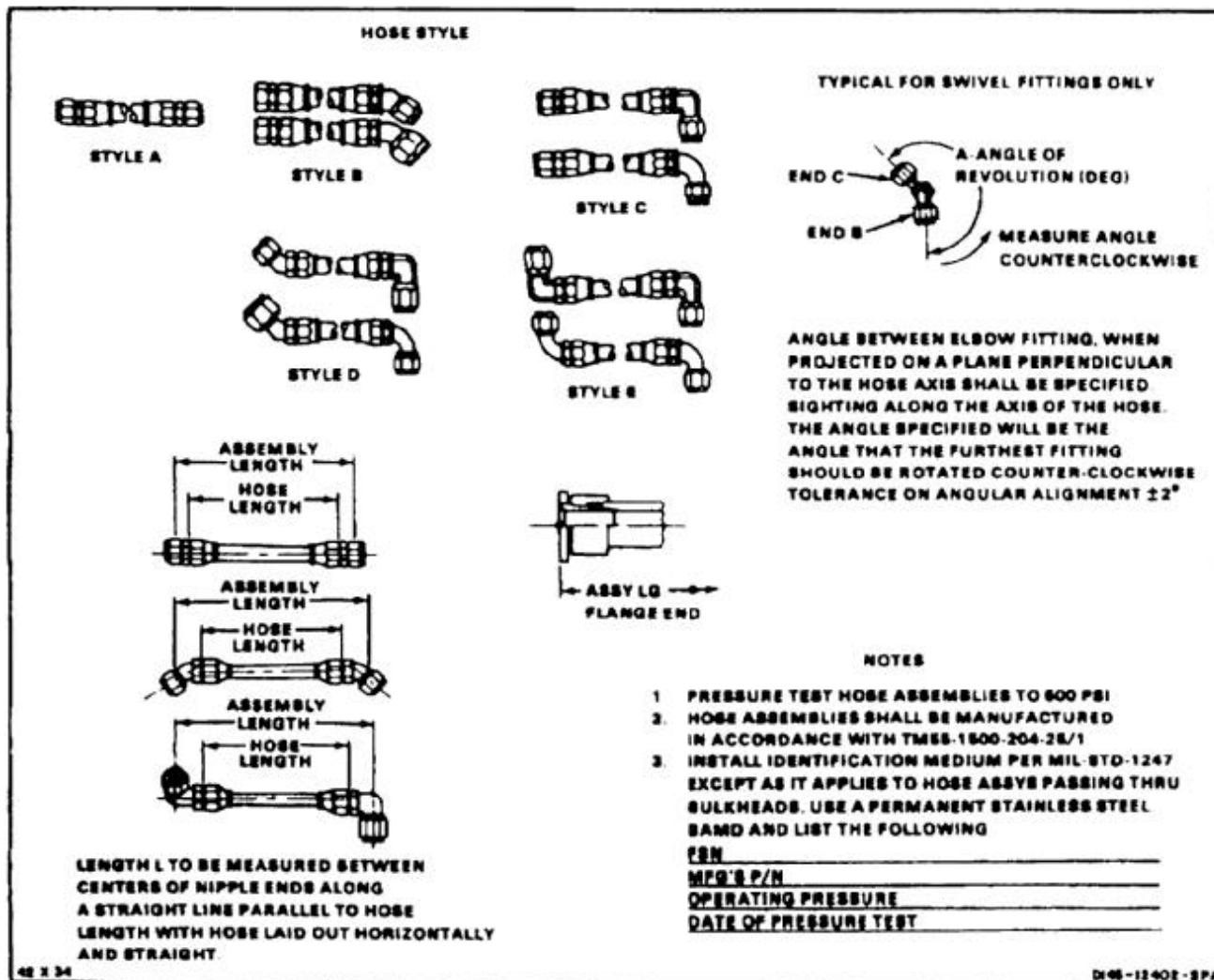

E-39 FUEL HOSE ASSEMBLIES (Continued)

E-39

HOSE ASSEMBLY PART NUMBER	HOSE PART NUMBER	END B	END C	ASSEMBLED HOSE LENGTH (INS.)	A-DEGREE OF ANGLE
114PS100-1	AE701-4	816-4	8846-4	16.75	
114PS100-4	AE701-4	816-4	816-4	29.75	
114PS100-7	AE701-4	8816-4	8891-4	24.75	330°
114PS100-10	AE701-10	8891-10D	—	51.50	
114PS100-15	AE701-4	8891-4	8846-4	10.00	270°
114PS100-19	AE701-4	816-4	8891-4	22.25	
114PS100-22	AE701-4	816-4	816-4	7.875	
114PS100-47	AE701-4	816-4	816-4	15.00	
114PS100-53	AE701-16	8891-16D	816-16D	31.00	
114PS100-95	AE701-4	8891-4	8891-4	5.25	180°
114PS100-97	AE701-10	816-10D	AE13716	60.00	
114PS100-98	AE701-8	816-8D	816-8D	16.00	
114PS100-100	AE701-4	816-4	816-4	11.00	
114PS100-101	AE701-4	816-4	8891-16D	8.50	
114PS403-1	AE701-16	8891-16D	8891-16D	35.75	45°
114PS403-2	AE701-16	8891-16D	8891-16D	35.75	315°
114PS404-1	AE701-4	816-6D	8891-6D	11.25	
114PS405-1	AE701-16	8846-16D	8891-16D	23.25	260°
114PS405-2	AE701-16	8846-16D	8891-16D	23.25	100°
114PS406-1	AE705796-1	8891-6D	816-6D	24.50	
114PS417-1	AE701-6	816-6D	8846-6D	7.25	
114PS418-1	AE701-6	8891-6D	8891-6D	8.12	90°
114PS421-1	AE701-16	816-16D	8846-16D	29.00	
114PS479-1	AE701-4	816-4	816-4	48.00	
114PS480-1*	AE601-32	AE23797R	8844-32D	34.31	
114PS480-2*	AE601-32	AE23786R	8844-32D	34.31	
114PS481-1	AE701-16	816-16D	8891-16D	25.00	
114PS482-1	AE701-16	816-16D	816-16D	25.50	
114PS483-1	AE701-4	816-4	816-4	72.00	
114PS484-1	AE701-16	816-16D	816-16D	28.25	
114PS485-1	AE701-6	8891-6D	816-6D	21.75	
114PS486-1	AE701-6	816-6D	8891-6D	18.50	
114PS492-1	AE705800-1	816-16D	816-16D	24.75	

* This hose requires a socket 516-32D to complete the assembly.

E-39 FUEL HOSE ASSEMBLIES (Continued)**E-39**

HOSE ASSEMBLY PART NUMBER	HOSE PART NUMBER	END B	END C	ASSEMBLED HOSE LENGTH (INS.)	A-DEGREE OF ANGLE
114PS487-1	AE701-16	816-16D	816-16D	29.50	
114PS487-2	AE701-16	816-16D	816-16D	20.00	
114PS495-1	AE701-16	816-16D	8891-16D	18.50	
114PS498-1	AE601-32	AE23797R*	AE23797R*	110.12	
114PS499-1	AE701-8	8891-8D	8846-8D	19.00	90°
114PS499-2	AE701-8	8891-8D	8891-8D	19.00	270°
114PS502-1	AE701-16	816-16D	8891-16D	50.75	
114PS502-2	AE701-16	816-16D	8891-16D	49.75	
114PS503-1	AE701-16	816-16D	8891-16D	60.50	
114PS505-1	AE701-16	816-16D	8846-16D	28.75	
114PS507-1	AE701-16	816-16D	8891-16D	70.75	
114PS511-1	AE701-6	816-6D	816-6D	18.12	
114PS516-1	AE701-16	816-16D	8891-16D	28.38	
114PS517-2	AE701-16	816-16D	8891-16D	45.75	
114PS519-1	AE701-6	816-6D	8846-6D	15.5	
114PS520-1	AE701-6	816-6D	816-6D	24.5	
114PS100-5	AE701-4	8846-4	8891-4	30.62	330°
145PS100-6	AE701-6	816-6D	8891-6D	29.00	
145PS452-1	AE701-16	816-6D	8891-16D	26.50	

* This hose requires a socket 516-32D to complete the assembly.

END OF TASK

NOTE

ALL DIMENSIONS IN INCHES.

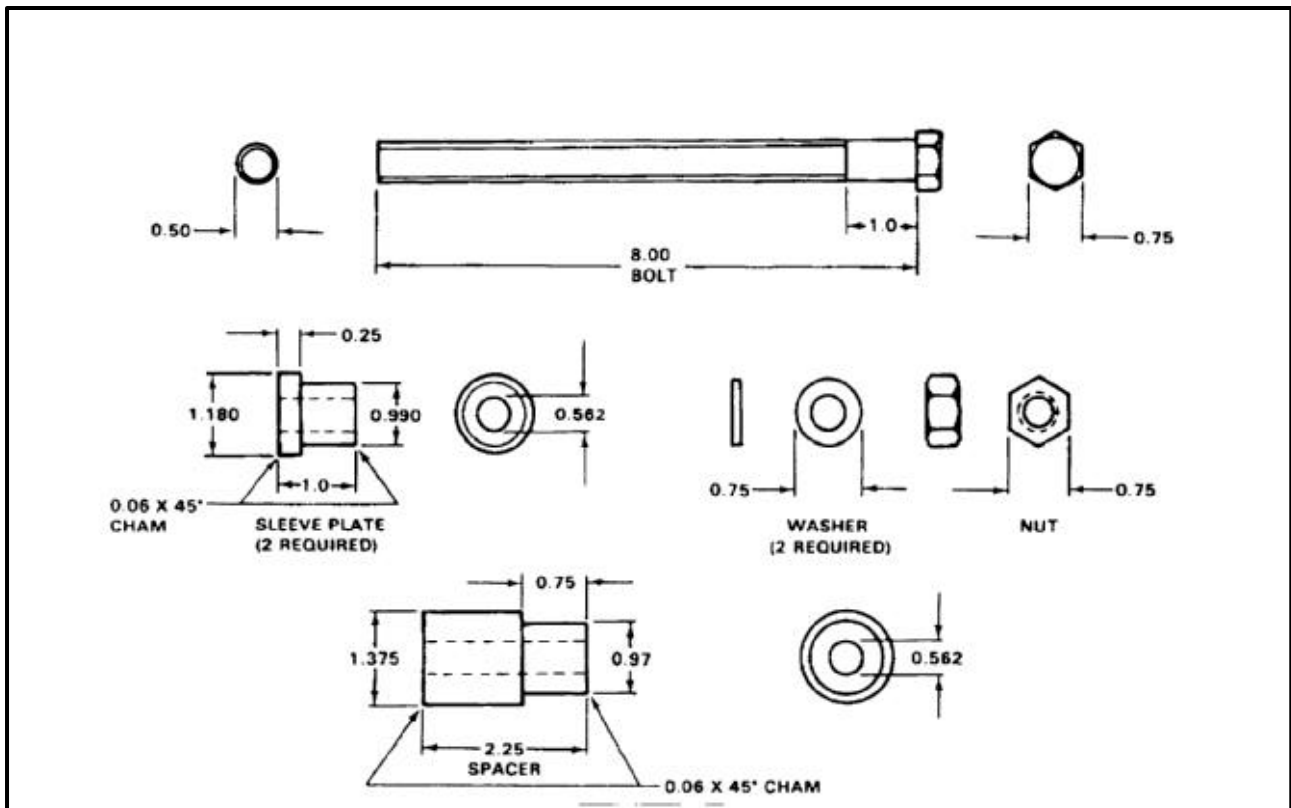

END OF TASK

E-41 SHOCK ABSORBER ROD END BEARING PUSHER ASSEMBLY

NOTES:

1. FABRICATE FROM 4140 STEEL.
2. ALL DIMENSIONS IN INCHES.

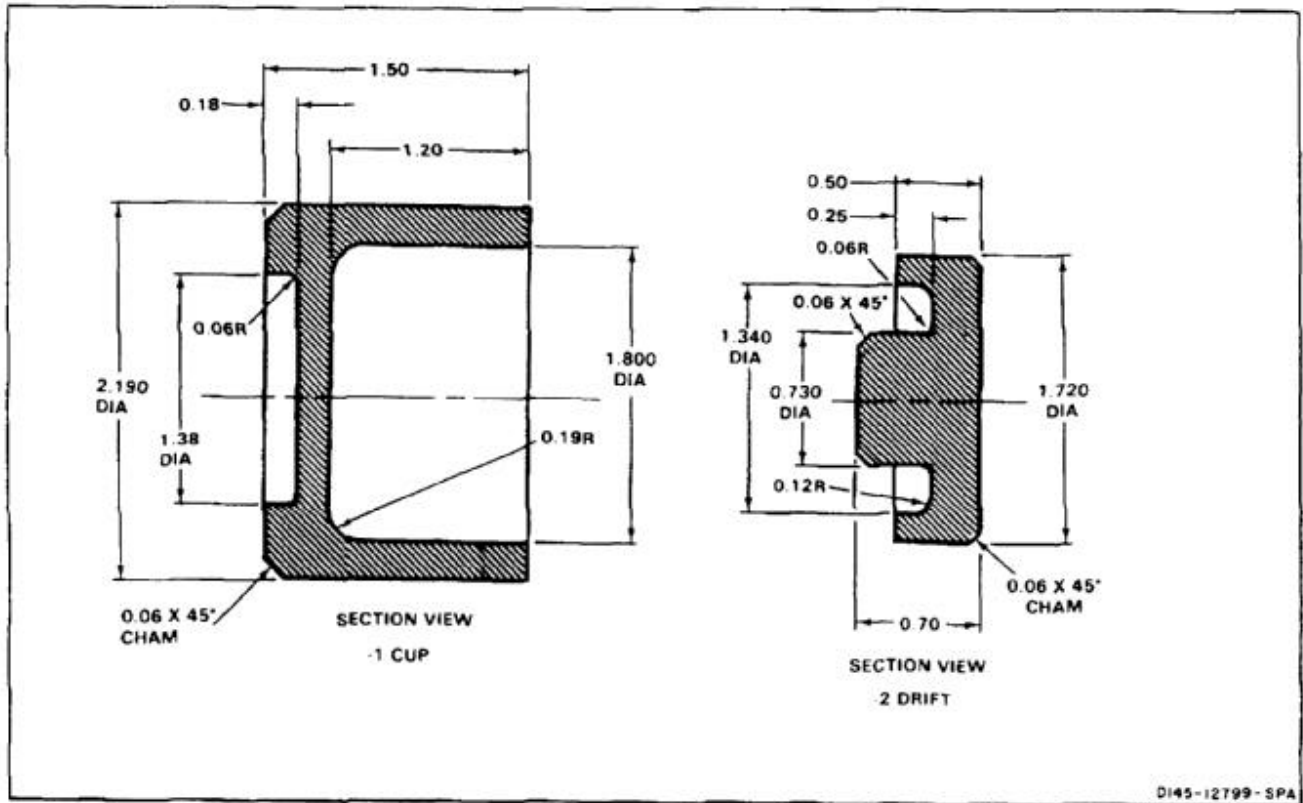

END OF TASK

FABRICATE FROM

CONNECTOR, ELECTRICAL, MS3110E-12-10P
 CONNECTOR, ELECTRICAL, MS3116E-12-10S
 HOOKUP WIRE, USE NO 20 GAGE WIRE AS
 REQUIRED.

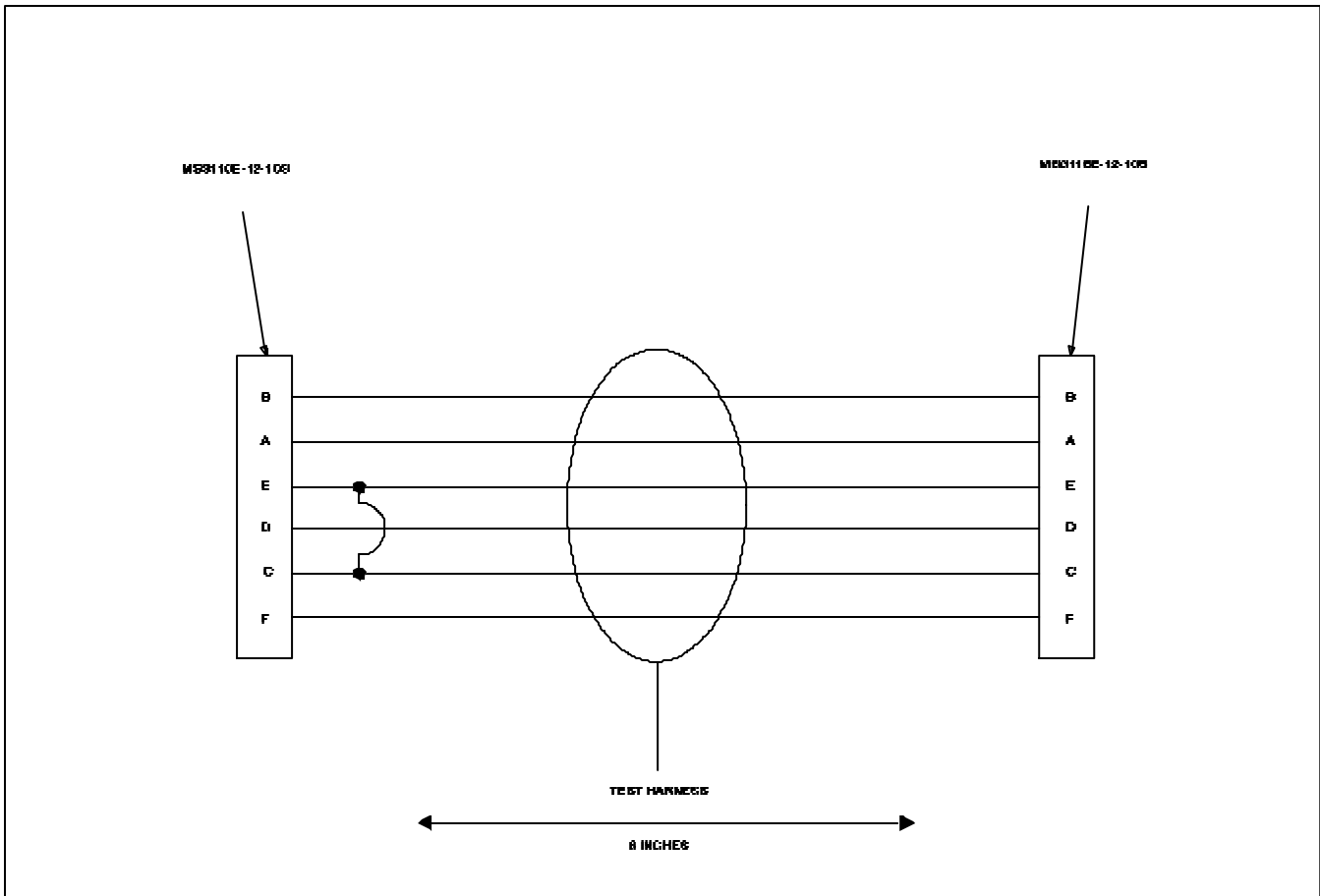

END OF TASK

NOTE

FABRICATE FROM:

	STANDARD PART NUMBER	NATIONAL STOCK NUMBER
RECEPTACLE	MS3472L16-26S	5935-00-568-3706
PLUG	MS3476L16-26P	5935-00-165-3342
PLUG	BNC	5935-00-080-4183
WIRE	BMS13-48/8-1-22 M22759/16-22-9	
COAXIAL CABLE	RG-188A/U	6145-00-918-9494

NOTES:

1. WIRE IS NO. 22 INSULATED BMS 13-48/8-1-22 M22759/16-22-9 UNLESS OTHERWISE NOTED.
2. TERMINATE SHIELD OF COAXIAL CABLE WITH WIRE JUMPERS CLOSE AS POSSIBLE TO BACK OF CONNECTOR. USING MS21981-080 INNER SLEEVE MS21980-156 OUTER SLEEVE. INSULATE SLEEVE TERMINATION WITH HEAT SHRINK TUBING.
3. TWO CABLE ASSEMBLIES REQUIRED FOR TEST SET UP.

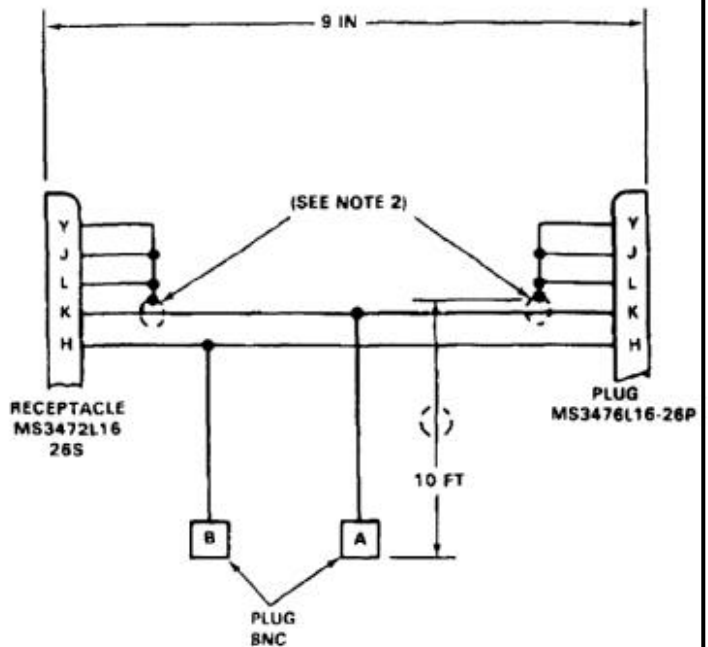

END OF TASK

NOTES:

1. FABRICATE FROM HARD WOOD DOWEL,
(E-160.1) 0.855-INCH DIAMETER.
2. ALL DIMENSIONS IN INCHES.

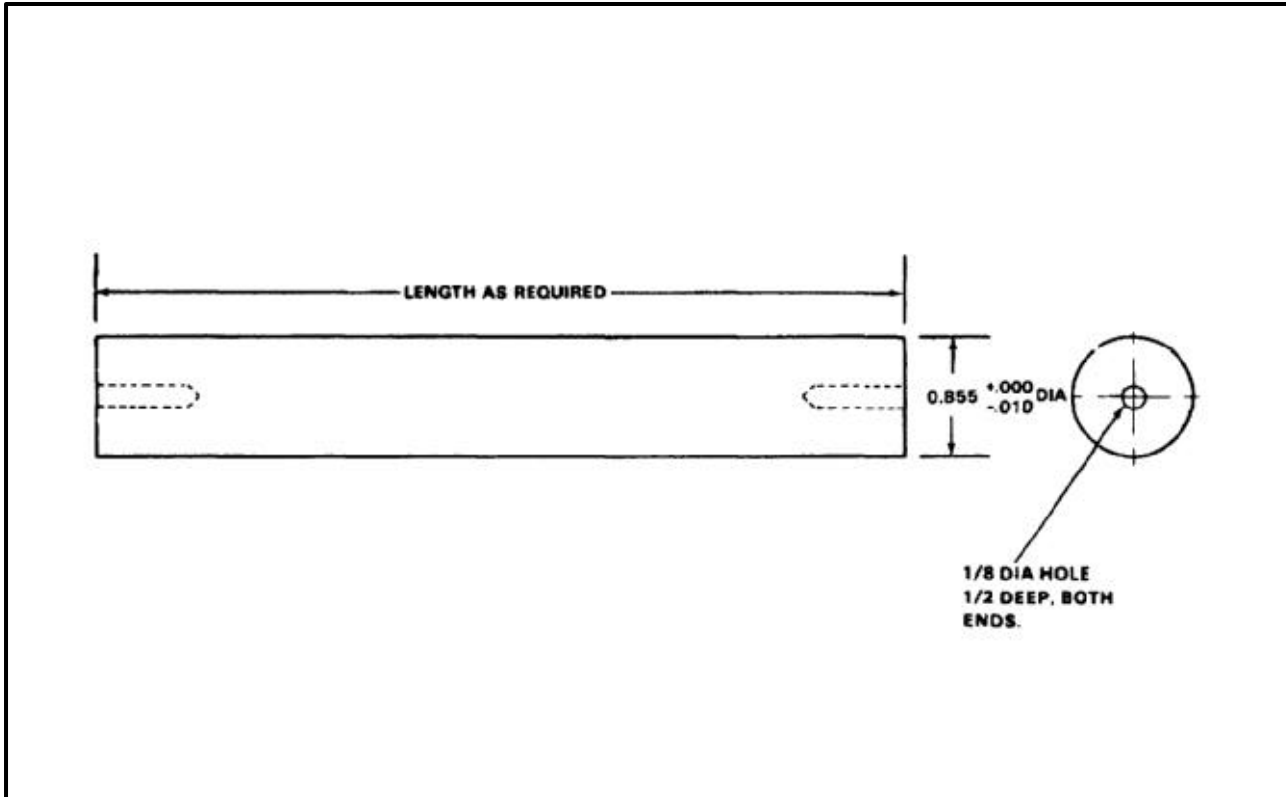

END OF TASK

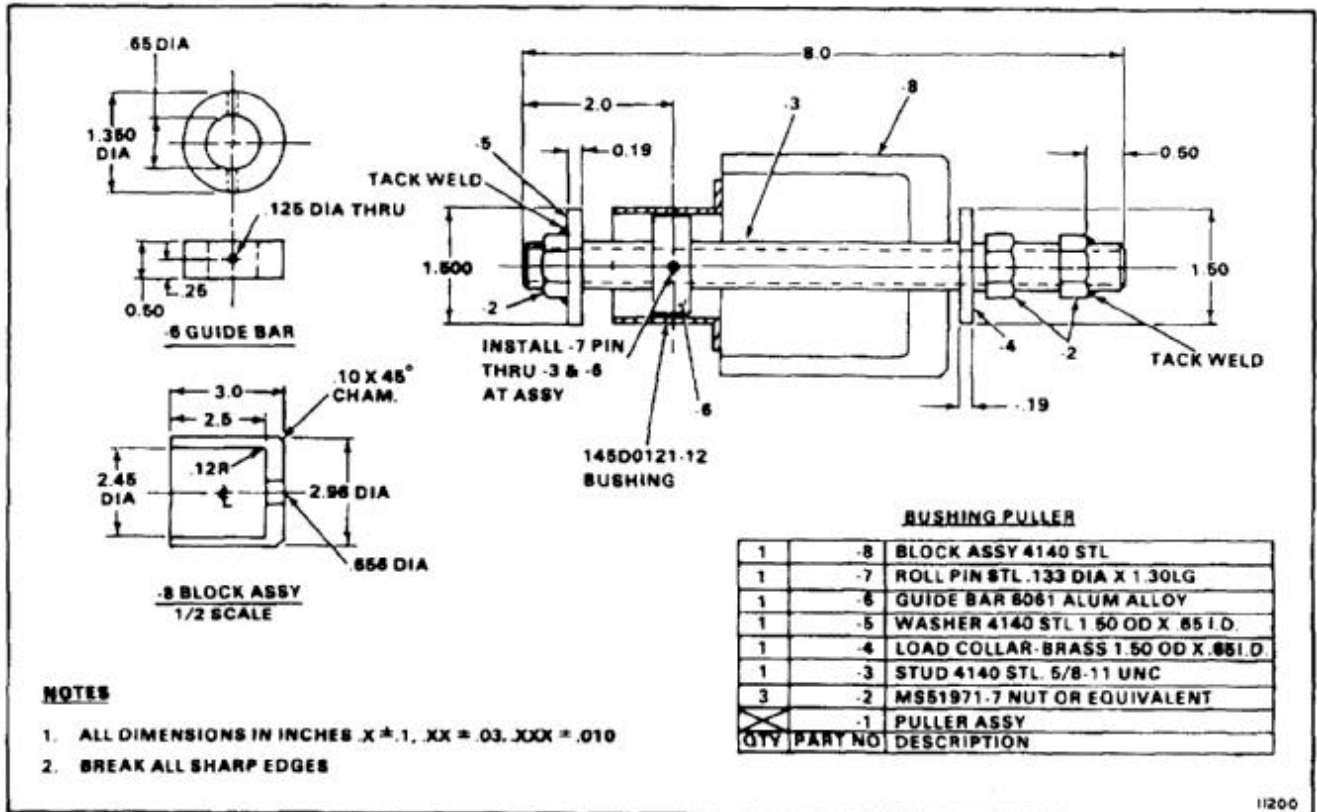

11200

NOTES:

1. MAKE FROM 0.063 CRES 301 OR 304, 1/4 HARD OR ANNEALED.
2. ALL DIMENSIONS IN INCHES.

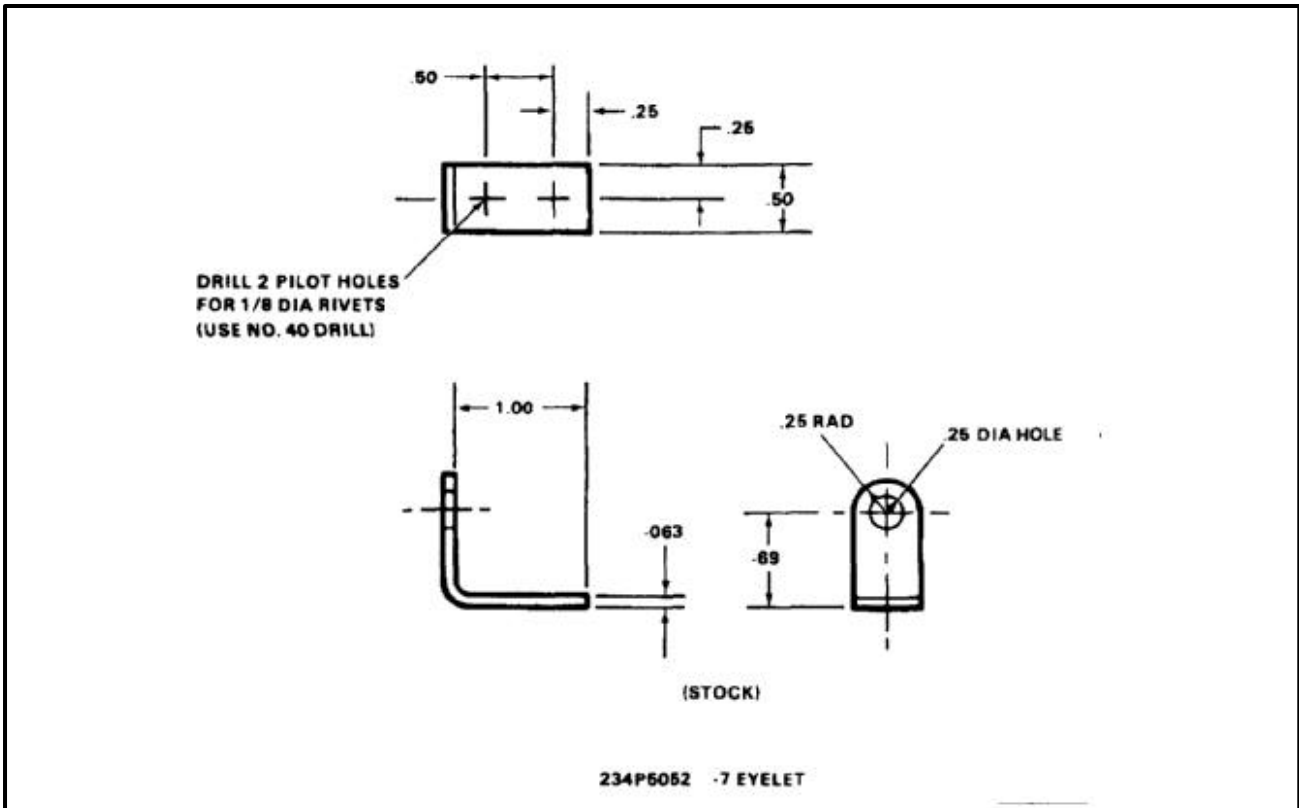

END OF TASK

NOTES:

1. MAKE FROM 0.063 CRES 301 OR 304, 1/4 HARD OR ANNEALED.
2. ALL DIMENSIONS IN INCHES.

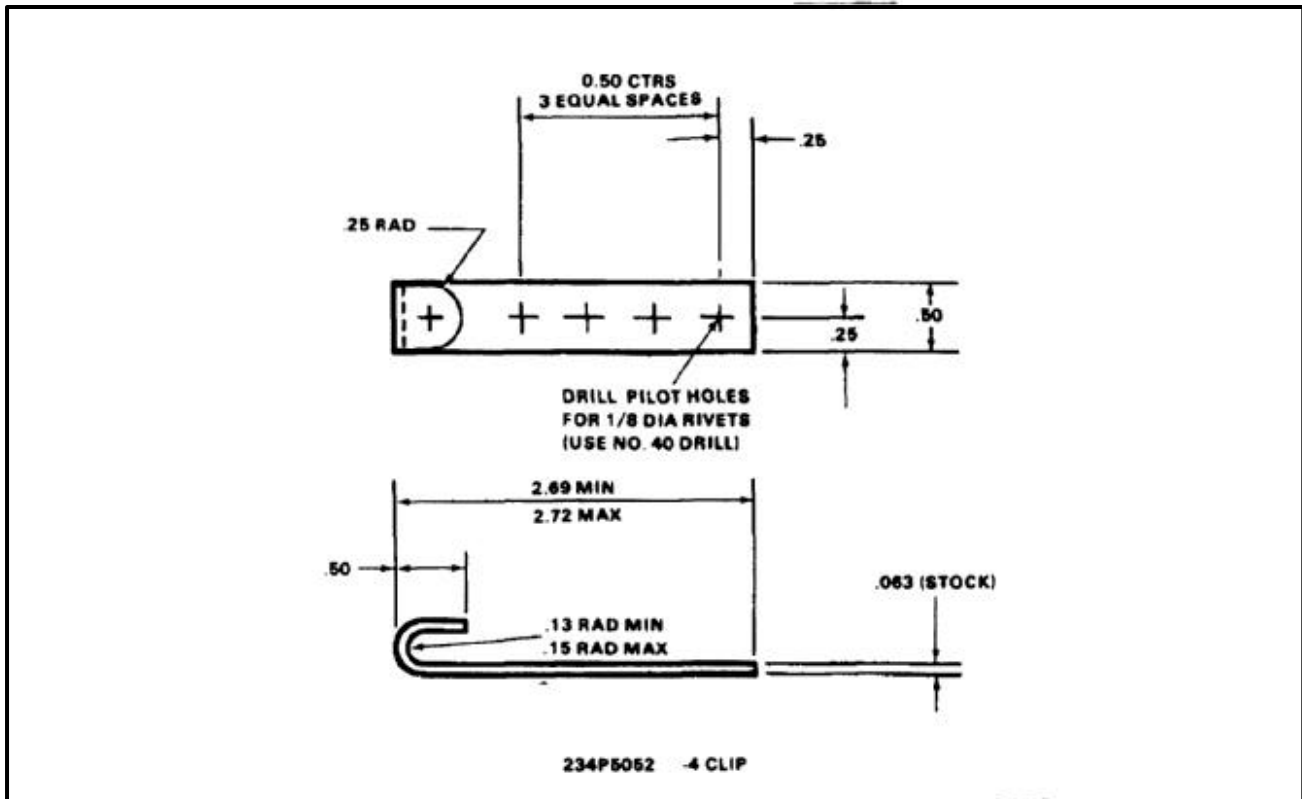

END OF TASK

NOTES:

1. MAKE FROM MS2001P8 HINGE (E196.1).
2. ALL DIMENSIONS IN INCHES.
3. FINISH WITH ZINC CHROMATE PRIMER (E291).

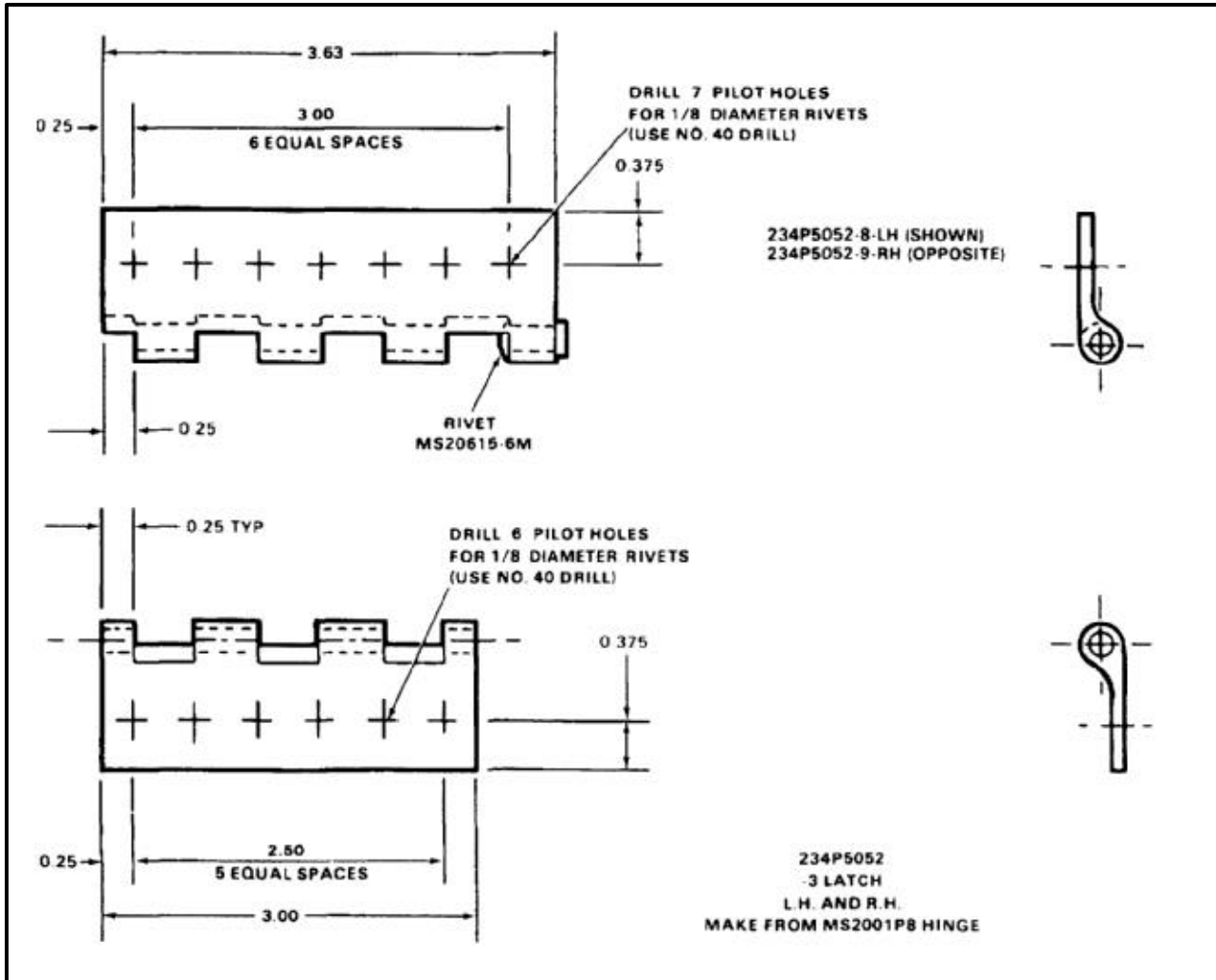

END OF TASK

NOTES:

1. FABRICATE FROM NSN 9535-00-167-2173 (E66.1).
2. ALL DIMENSIONS IN INCHES.

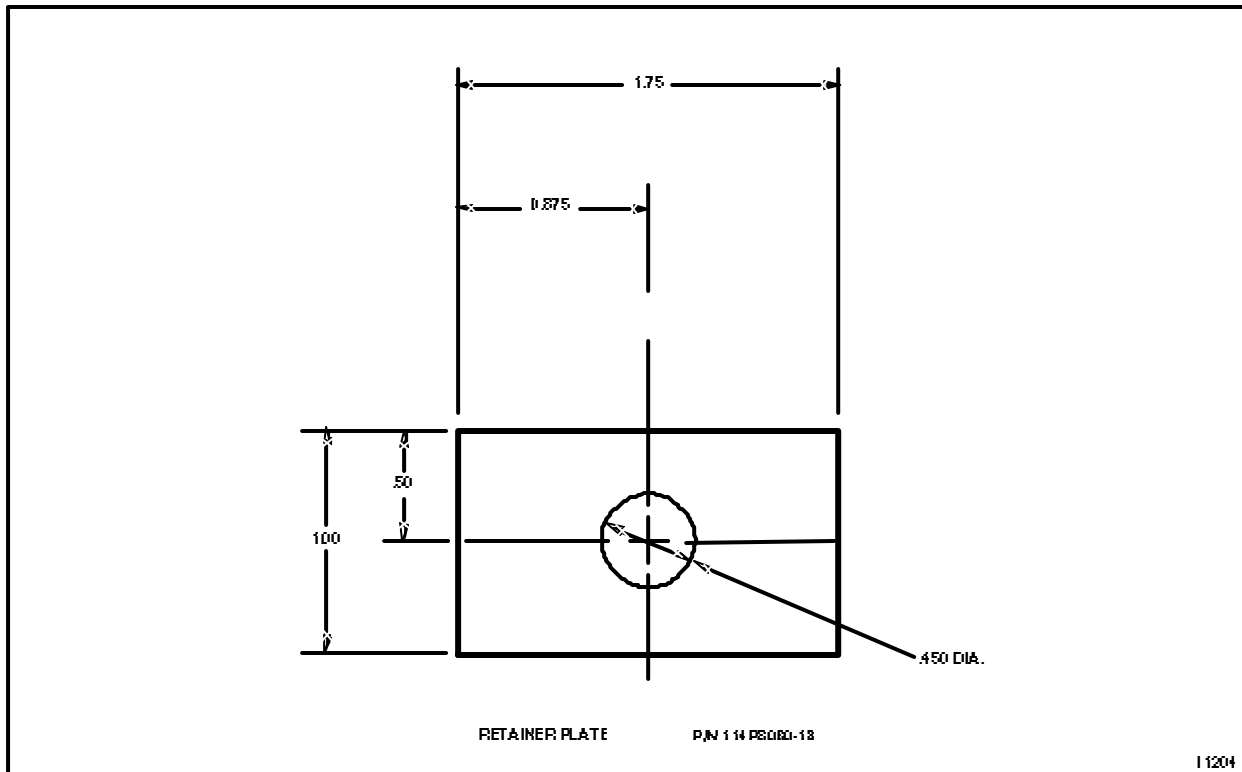

END OF TASK

A. Tube Fabrication Data SHEET 1 OF 13

NOMENCLATURE	PART NUMBER	FUNCTION	FINISHED LENGTH ALONG TUBE C/L	MATERIAL	NOTES
TUBE	114E1042-418	PITOT-STATIC	18	1/4 O.D. ALUMINUM	3
TUBE ASSY	114E4048-125	HEATER	12-5/8	3/8 O.D. CRES STEEL	1, 2
TUBE ASSY	114E4048-151	HEATER	9	1/2 O.D. CRES STEEL	1, 2
TUBE ASSY	145H1301-1	BRAKE	19-7/8	1/4 O.D. CRES STEEL	1, 2
TUBE ASSY	145H1301-3	BRAKE	19-1/4	1/4 O.D. CRES STEEL	1, 2
TUBE	145H1301-6	BRAKE	10-3/4	1/4 O.D. CRES STEEL	1, 2
TUBE ASSY	145H1301-7	BRAKE	13-3/4	1/4 O.D. CRES STEEL	1, 2
TUBE ASSY	145H1301-9	BRAKE	27-1/8	1/4 O.D. CRES STEEL	1, 2
TUBE ASSY	145H1301-11	BRAKE	30-1/2	1/4 O.D. CRES STEEL	1, 2
TUBE ASSY	145H1301-13	BRAKE	4	1/4 O.D. CRES STEEL	1, 2
TUBE ASSY	145H1301-15	BRAKE	7-5/8	1/4 O.D. CRES STEEL	1, 2
TUBE ASSY	145H1301-17	BRAKE	23	1/4 O.D. CRES STEEL	1, 2
TUBE ASSY	145H1301-21	BRAKE PRESS	9-1/4	1/4 O.D. CRES STEEL	1, 2
TUBE ASSY	145H1301-23	BOOST PRESS #1	17	1/4 O.D. CRES STEEL	1, 2
TUBE ASSY	145H1301-25	BRAKE PRESS	5-7/8	1/4 O.D. CRES STEEL	1, 2
TUBE ASSY	145H1301-27	BRAKE	8-7/8	1/4 O.D. CRES STEEL	1, 2
TUBE	145H1301-30	BRAKE PRESS	17-5/8	1/4 O.D. CRES STEEL	1, 2
TUBE ASSY	145H1301-31	BRAKE	8	1/4 O.D. CRES STEEL	1, 2
TUBE ASSY	145H1301-33	BRAKE PRESS	9-3/4	1/4 O.D. CRES STEEL	1, 2
TUBE ASSY	145H1301-35	BOOST PRESS #1	29-1/2	1/4 O.D. CRES STEEL	1, 2
TUBE	145H1301-38	BRAKE PRESS	10-5/16	1/4 O.D. CRES STEEL	1, 2
TUBE ASSY	145H1301-39	HOIST PRESS	11-7/16	1/4 O.D. CRES STEEL	1, 2
TUBE	145H1301-42	BRAKE PRESS	6-1/2	1/4 O.D. CRES STEEL	1, 2
TUBE ASSY	145H1301-45	BRAKE	30	1/4 O.D. CRES STEEL	1, 2
TUBE ASSY	145H1301-47	BRAKE	31-7/8	1/4 O.D. CRES STEEL	1, 2
TUBE ASSY	145H1301-52	BRAKE PRESS	51-7/16	1/4 O.D. CRES STEEL	1, 2
TUBE ASSY	145H1301-53	BRAKE	78	1/4 O.D. CRES STEEL	1, 2
TUBE ASSY	145H1301-55	BRAKE	75-1/2	1/4 O.D. CRES STEEL	1, 2
TUBE ASSY	145H1301-59	BRAKE PRESS	80	3/8 O.D. CRES STEEL	1, 2
TUBE ASSY	145H1301-61	BOOST PRESS #1	57-1/2	3/8 O.D. CRES STEEL	1, 2
TUBE	145H1301-64	BOOST PRESS #1	33-1/2	3/8 O.D. CRES STEEL	1, 2
TUBE ASSY	145H1301-65	BOOST PRESS #1	3-5/16	3/8 O.D. CRES STEEL	1, 2
TUBE	145H1301-68	BOOST PRESS #1	51-3/8	3/8 O.D. CRES STEEL	1, 2
TUBE	145H1301-74	BOOST PRESS #2	75	3/8 O.D. CRES STEEL	1, 2
TUBE ASSY	145H1301-75	BOOST PRESS #2	9-1/2	3/8 O.D. CRES STEEL	1, 2

A. Tube Fabrication Data SHEET 2 OF 13

NOMENCLATURE	PART NUMBER	FUNCTION	FINISHED LENGTH ALONG TUBE C/L	MATERIAL	NOTES
TUBE	145H1301-78	BOOST PRESS #2	9	3/8 O.D. CRES STEEL	1, 2
TUBE	145H1301-80	BOOST PRESS #1	5-3/8	3/8 O.D. CRES STEEL	1, 2
TUBE ASSY	145H1301-81	BOOST PRESS #2	21-5/16	1/4 O.D. CRES STEEL	1, 2
TUBE ASSY	145H1301-83	BOOST PRESS #2	20-3/16	1/4 O.D. CRES STEEL	1, 2
TUBE	145H1301-86	BOOST PRESS #2	37-3/8	1/4 O.D. CRES STEEL	1, 2
TUBE	145H1301-88	BOOST PRESS #2	34-13/16	1/4 O.D. CRES STEEL	1, 2
TUBE ASSY	145H1301-89	BOOST PRESS #1	22-3/8	1/4 O.D. CRES STEEL	1, 2
TUBE ASSY	145H1301-91	BRAKE PRESS	41	1/4 O.D. CRES STEEL	1, 2
TUBE ASSY	145H1301-93	HOIST PRESS	5-1/4	1/4 O.D. CRES STEEL	1, 2
TUBE ASSY	145H1301-95	BRAKE	34-3/4	1/4 O.D. CRES STEEL	1, 2
TUBE ASSY	145H1301-97	BRAKE PRESS	23-3/4	3/8 O.D. CRES STEEL	1, 2
TUBE ASSY	145H1301-99	BRAKE	90	1/4 O.D. CRES STEEL	1, 2
TUBE ASSY	145H1301-101	BRAKE	49	1/4 O.D. CRES STEEL	1, 2
TUBE ASSY	145H1301-103	BRAKE	33-3/8	1/4 O.D. CRES STEEL	1, 2
TUBE ASSY	145H1301-105	UTILITY PRESS	19-7/8	3/8 O.D. CRES STEEL	1, 2
TUBE ASSY	145H1301-115	BOOST PRESS #1	11-11/16	3/8 O.D. CRES STEEL	1, 2
TUBE ASSY	145H1301-117	BOOST PRESS #1	22-5/16	1/2 O.D. CRES STEEL	1, 2
TUBE ASSY	145H1301-119	BOOST PRESS #1	54-15/16	3/8 O.D. CRES STEEL	1, 2
TUBE ASSY	145H1301-121	BOOST PRESS #2	39-1/16	3/8 O.D. CRES STEEL	1, 2
TUBE ASSY	145H1301-123	UTILITY PRESS	13-3/16	3/8 O.D. CRES STEEL	1, 2
TUBE ASSY	145H1301-125	UTILITY PRESS	55-1/4	3/8 O.D. CRES STEEL	1, 2
TUBE ASSY	145H1301-127	PRESS	52-5/8	1/2 O.D. CRES STEEL	1, 2
TUBE ASSY	145H1301-129	BOOST PRESS #1	21-1/4	1/2 O.D. CRES STEEL	1, 2
TUBE ASSY	145H1301-131	BOOST PRESS #1	45	1/2 O.D. CRES STEEL	1, 2
TUBE ASSY	145H1301-133	BOOST PRESS #1	36	1/2 O.D. CRES STEEL	1, 2
TUBE	145H1301-136	PRESS	46-3/8	3/8 O.D. CRES STEEL	1, 2
TUBE ASSY	145H1301-137	PRESS	24-7/8	1/4 O.D. CRES STEEL	1, 2
TUBE ASSY	145H1301-139	BOOST PRESS #1	19-1/4	5/8 O.D. CRES STEEL	1, 2
TUBE ASSY	145H1301-141	BRAKE PRESS	43-1/4	3/8 O.D. CRES STEEL	1, 2
TUBE ASSY	145H1301-143	BRAKE	36-1/2	1/4 O.D. CRES STEEL	1, 2
TUBE	145H1301-146	BRAKE	33-1/2	1/4 O.D. CRES STEEL	1, 2
TUBE ASSY	145H1301-151	BRAKE PRESS	28-9/16	1/4 O.D. CRES STEEL	1, 2
TUBE ASSY	145H1301-155	UTILITY PRESS	9-3/4	3/8 O.D. CRES STEEL	1, 2
TUBE	145H1301-158	HOIST PRESS	7	3/8 O.D. CRES STEEL	1, 2

A. Tube Fabrication Data SHEET 3 OF 13

NOMENCLATURE	PART NUMBER	FUNCTION	FINISHED LENGTH ALONG TUBE C/L	MATERIAL	NOTES
TUBE	145H1301-160	HOIST "UP"	12-3/8	3/8 O.D. CRES STEEL	1, 2
TUBE ASSY	145H1301-161	HOIST "DOWN"	20-1/2	3/8 O.D. CRES STEEL	1, 2
TUBE ASSY	145H1301-163	HOIST "UP"	27-7/8	3/8 O.D. CRES STEEL	1, 2
TUBE ASSY	145H1301-165	HOIST "DOWN"	20-9/16	3/8 O.D. CRES STEEL	1, 2
TUBE ASSY	145H1301-169	HOIST BRAKE	52-3/8	1/4 O.D. CRES STEEL	1, 2
TUBE ASSY	145H1302-1	BOOST RETURN #1	19-3/4	1/4 O.D. CRES STEEL	1, 2
TUBE ASSY	145H1302-3	BOOST RETURN #2	19	1/4 O.D. CRES STEEL	1, 2
TUBE ASSY	145H1302-5	BOOST RETURN #1	19-7/8	1/4 O.D. CRES STEEL	1, 2
TUBE ASSY	145H1302-7	BOOST RETURN #2	18-7/8	1/4 O.D. CRES STEEL	1, 2
TUBE ASSY	145H1302-9	BOOST RETURN #1	5-1/2	3/8 O.D. ALUM ALLOY	3
TUBE ASSY	145H1302-11	BOOST RETURN #1	52-1/4	3/8 O.D. ALUM ALLOY	3
TUBE ASSY	145H1302-13	BOOST RETURN #2	7-1/2	3/8 O.D. ALUM ALLOY	3
TUBE	145H1302-18	BOOST RETURN #2	52-1/2	3/8 O.D. ALUM ALLOY	3
TUBE	145H1302-20	BOOST RETURN #2	16-3/16	3/8 O.D. ALUM ALLOY	3
TUBE ASSY	146H1302-21	BOOST RETURN #2	54-1/4	3/8 O.D. ALUM ALLOY	3
TUBE ASSY	145H1302-23	BRAKE RETURN	24-1/2	3/8 O.D. ALUM ALLOY	3
TUBE ASSY	145H1302-25	RETURN	19-7/8	3/8 O.D. ALUM ALLOY	3
TUBE ASSY	145H1302-27	CASE RETURN	23-3/4	3/8 O.D. ALUM ALLOY	3
TUBE ASSY	145H1302-29	BOOST SUCTION	19-3/8	3/4 O.D. ALUM ALLOY	3
TUBE ASSY	145H1302-31	UTILITY RETURN	13-1/8	3/8 O.D. ALUM ALLOY	3
TUBE	145H1302-34	UTILITY RETURN	42-1/2	1/2 O.D. ALUM ALLOY	3
TUBE ASSY	145H1302-35	UTILITY RETURN	24-1/8	3/8 O.D. ALUM ALLOY	3
TUBE ASSY	145H1302-37	UTILITY RETURN	30-3/16	1/2 O.D. ALUM ALLOY	3
TUBE ASSY	145H1302-39	UTILITY RETURN	41-5/8	3/8 O.D. ALUM ALLOY	3
TUBE ASSY	145H1302-41	BOOST RETURN #2	45-3/8	3/8 O.D. ALUM ALLOY	3
TUBE	145H1302-44	RETURN	23-3/8	3/4 O.D. ALUM ALLOY	3
TUBE	145H1302-46	BOOST SUCTION	20-3/4	1 O.D. ALUM ALLOY	3
TUBE ASSY	145H1302-47	BOOST SUCTION	12-5/8	3/4 O.D. ALUM ALLOY	3
TUBE	145H1302-50	BOOST SUCTION	5-7/8	1/2 O.D. ALUM ALLOY	3
TUBE ASSY	145H1302-51	RETURN	34-7/16	5/8 O.D. ALUM ALLOY	3
TUBE ASSY	145H1302-53	BOOST RETURN #1	21-1/4	5/8 O.D. ALUM ALLOY	3
TUBE ASSY	145H1302-55	BOOST RETURN #1	46-3/4	5/8 O.D. ALUM ALLOY	3
TUBE ASSY	145H1302-57	BOOST RETURN #1	38-1/4	5/8 O.D. ALUM ALLOY	3
TUBE ASSY	145H1302-59	CASE DRAIN	16-1/8	3/8 O.D. ALUM ALLOY	3
TUBE ASSY	145H1302-61	CASE DRAIN	11-7/16	1/2 O.D. ALUM ALLOY	3

A. Tube Fabrication Data SHEET 4 OF 13

NOMENCLATURE	PART NUMBER	FUNCTION	FINISHED LENGTH ALONG TUBE C/L	MATERIAL	NOTES
TUBE ASSY	145H1302-63	CASE DRAIN	32-1/4	3/8 O.D. ALUM ALLOY	3
TUBE	145H1302-66	OVERBOARD DRAIN	9-3/4	1/4 O.D. ALUM ALLOY	3
TUBE ASSY	145H1302-67	OVERBOARD DRAIN	22-11/16	1/4 O.D. ALUM ALLOY	3
TUBE ASSY	145H1302-69	OVERBOARD DRAIN	34-1/4	1/4 O.D. ALUM ALLOY	3
TUBE	145H1302-72	OVERBOARD DRAIN	7-1/2	1/4 O.D. ALUM ALLOY	3
TUBE ASSY	145H1302-73	OVERBOARD DRAIN	30-7/16	1/4 O.D. ALUM ALLOY	3
TUBE	145H1302-76	OVERBOARD DRAIN	54	1/4 O.D. ALUM ALLOY	3
TUBE ASSY	145H1302-77	UTILITY RETURN	8	1/2 O.D. ALUM ALLOY	3
TUBE ASSY	145H1302-79	HOIST RETURN	8-7/8	3/8 O.D. ALUM ALLOY	3
TUBE	145H1302-82	HOIST RETURN	23-7/16	3/8 O.D. ALUM ALLOY	3
TUBE ASSY	145H1302-83	HOIST RETURN	12-3/8	3/8 O.D. ALUM ALLOY	3
TUBE	145H1302-86	HOIST RETURN	11-15/16	3/8 O.D. ALUM ALLOY	3
TUBE	145H1302-88	HOIST RETURN	7-1/2	3/8 O.D. ALUM ALLOY	3
TUBE ASSY	145H1302-89	HOIST RETURN	8-15/16	3/8 O.D. ALUM ALLOY	3
TUBE ASSY	145H1302-93	BRAKE RETURN	44	3/8 O.D. ALUM ALLOY	3
TUBE ASSY	145H1302-95	BOOST RETURN #1	15-1/4	3/8 O.D. ALUM ALLOY	3
TUBE ASSY	145H1302-97	BOOST RETURN #1	13-3/8	3/8 O.D. ALUM ALLOY	3
TUBE	145H1302-100	BOOST RETURN #1	59-1/16	3/8 O.D. ALUM ALLOY	3
TUBE ASSY	145H1302-103	BRAKE RETURN	9-1/4	3/8 O.D. ALUM ALLOY	3
TUBE ASSY	145H1302-105	BRAKE RETURN	5-7/8	3/8 O.D. ALUM ALLOY	3
TUBE	145H1302-108	BRAKE RETURN	20	3/8 O.D. ALUM ALLOY	3
TUBE ASSY	145H1302-109	BRAKE RETURN	9-1/2	3/8 O.D. ALUM ALLOY	3
TUBE	145H1302-112	BRAKE RETURN	10-5/16	3/8 O.D. ALUM ALLOY	3
TUBE	145H1302-114	BRAKE RETURN	6	3/8 O.D. ALUM ALLOY	3
TUBE	145H1302-116	BRAKE RETURN	37-3/16	3/8 O.D. ALUM ALLOY	3
TUBE ASSY	145H1302-117	BRAKE RETURN	82-5/8	3/8 O.D. ALUM ALLOY	3
TUBE ASSY	145H1302-119	BRAKE RETURN	38-5/8	3/8 O.D. ALUM ALLOY	3
TUBE ASSY	145H1302-123	CASE DRAIN	4-11/16	3/8 O.D. ALUM ALLOY	3
TUBE ASSY	145H1302-125	HOIST RETURN	18-13/16	3/8 O.D. ALUM ALLOY	3
TUBE ASSY	145H1302-127	BOOST RETURN #1	15-1/4	5/8 O.D. ALUM ALLOY	3
TUBE	145H1401-2	UTILITY PRESS	26-3/4	3/8 O.D. CRES STEEL	1, 2

A. Tube Fabrication Data SHEET 5 OF 13

NOMENCLATURE	PART NUMBER	FUNCTION	FINISHED LENGTH ALONG TUBE C/L	MATERIAL	NOTES
TUBE	145H1401-4	CARGO RELEASE	7	3/8 O.D. CRES STEEL	1, 2
TUBE ASSY	145H1401-5	UTILITY PRESS	96	3/8 O.D. CRES STEEL	1, 2
TUBE ASSY	145H1401-7	BRAKE PRESS	144	3/8 O.D. CRES STEEL	1, 2
TUBE	145H1401-10	BRAKE	144	1/4 O.D. CRES STEEL	1, 2
TUBE ASSY	145H1401-11	BOOST PRESS #1	144	3/8 O.D. CRES STEEL	1, 2
TUBE	145H1401-14	UTILITY PRESS	30	3/8 O.D. CRES STEEL	1, 2
TUBE ASSY	145H1401-15	BRAKE PRESS	114-1/4	3/8 O.D. CRES STEEL	1, 2
TUBE ASSY	145H1401-17	BOOST PRESS #1	129-1/2	3/8 O.D. CRES STEEL	1, 2
TUBE ASSY	145H1401-19	UTILITY PRESS	144	3/8 O.D. CRES STEEL	1, 2
TUBE ASSY	145H1401-21	BRAKE	129-3/4	1/4 O.D. CRES STEEL	1, 2
TUBE ASSY	145H1401-23	BOOST PRESS #2	136-3/4	3/8 O.D. CRES STEEL	1, 2
TUBE	145H1401-26	BRAKE	78-5/8	1/4 O.D. CRES STEEL	1, 2
TUBE ASSY	145H1401-27	BOOST PRESS #2	144	3/8 O.D. CRES STEEL	1, 2
TUBE ASSY	145H1401-29	BRAKE	50	1/4 O.D. CRES STEEL	1, 2
TUBE ASSY	145H1401-31	BRAKE	144	1/4 O.D. CRES STEEL	1, 2
TUBE ASSY	145H1401-33	BRAKE	12-1/2	1/4 O.D. CRES STEEL	1, 2
TUBE ASSY	145H1401-35	BRAKE	27-5/8	1/4 O.D. CRES STEEL	1, 2
TUBE ASSY	145H1401-37	BRAKE	50-3/8	1/4 O.D. CRES STEEL	1, 2
TUBE ASSY	145H1401-41	BRAKE PRESS	56-1/2	3/8 O.D. CRES STEEL	1, 2
TUBE ASSY	145H1401-43	BRAKE	44	1/4 O.D. CRES STEEL	1, 2
TUBE ASSY	145H1401-45	BRAKE	49-1/2	1/4 O.D. CRES STEEL	1, 2
TUBE ASSY	145H1401-48	BRAKE	29-11/16	1/4 O.D. CRES STEEL	1, 2
TUBE ASSY	145H1401-49	BRAKE	56-3/4	1/4 O.D. CRES STEEL	1, 2
TUBE ASSY	145H1401-51	BRAKE	42-1/8	1/4 O.D. CRES STEEL	1, 2
TUBE ASSY	145H1401-53	BRAKE	16-1/2	1/4 O.D. CRES STEEL	1, 2
TUBE ASSY	145H1401-57	CARGO RELEASE	58	3/8 O.D. CRES STEEL	1, 2
TUBE ASSY	145H1401-59	CARGO RELEASE	47	3/8 O.D. CRES STEEL	1, 2
TUBE ASSY	145H1401-61	BRAKE	16-3/16	1/4 O.D. CRES STEEL	1, 2
TUBE ASSY	145H1401-63	CARGO RELEASE	42-13/16	1/4 O.D. CRES STEEL	1, 2
TUBE ASSY	145H1401-65	BRAKE	13-3/4	1/4 O.D. CRES STEEL	1, 2
TUBE	145H1401-68	UTILITY PRESS	53	3/8 O.D. CRES STEEL	1, 2
TUBE	145H1401-70	BRAKE	47-3/4	3/8 O.D. CRES STEEL	1, 2
TUBE ASSY	145H1401-71	UTILITY PRESS	58-5/8	3/8 O.D. CRES STEEL	1, 2
TUBE ASSY	145H1401-73	BRAKE PRESS	51	3/8 O.D. CRES STEEL	1, 2

A. Tube Fabrication Data SHEET 6 OF 13

NOMENCLATURE	PART NUMBER	FUNCTION	FINISHED LENGTH ALONG TUBE C/L	MATERIAL	NOTES
TUBE ASSY	145H1401-75	BRAKE	3-1/4	1/4 O.D. CRES STEEL	1, 2
TUBE ASSY	145H1401-77	BRAKE	6-3/16	1/4 O.D. CRES STEEL	1, 2
TUBE ASSY	145H1401-79	BRAKE PRESS	31	3/8 O.D. CRES STEEL	1, 2
TUBE ASSY	145H1401-81	CARGO HOOK	32	3/8 O.D. CRES STEEL	1, 2
TUBE	145H1402-2	UTILITY RETURN	7-3/8	1/4 O.D. ALUM ALLOY	3
TUBE ASSY	145H1402-3	UTILITY RETURN	103	1/2 O.D. ALUM ALLOY	3
TUBE ASSY	145H1402-5	BRAKE RETURN	138	3/8 O.D. ALUM ALLOY	3
TUBE ASSY	145H1402-7	BOOST RETURN #1	138	3/8 O.D. ALUM ALLOY	3
TUBE ASSY	145H1402-9	BRAKE RETURN	120-3/4	3/8 O.D. ALUM ALLOY	3
TUBE ASSY	145H1402-11	BOOST RETURN #2	133-5/8	3/8 O.D. ALUM ALLOY	3
TUBE	145H1402-14	UTILITY RETURN	32	1/2 O.D. ALUM ALLOY	3
TUBE ASSY	145H1402-15	BOOST RETURN #1	135	3/8 O.D. ALUM ALLOY	3
TUBE ASSY	145H1402-17	UTILITY RETURN	138	1/2 O.D. ALUM ALLOY	3
TUBE ASSY	145H1402-19	BOOST RETURN #2	143	3/8 O.D. ALUM ALLOY	3
TUBE ASSY	145H1402-21	BRAKE RETURN	57-3/4	3/8 O.D. ALUM ALLOY	3
TUBE ASSY	145H1402-23	BRAKE RETURN	3	1/2 O.D. ALUM ALLOY	3
TUBE ASSY	145H1402-25	BRAKE RETURN	21-3/4	3/8 O.D. ALUM ALLOY	3
TUBE	145H1402-28	UTILITY RETURN	66-5/8	1/2 O.D. ALUM ALLOY	3
TUBE	145H1402-30	BRAKE RETURN	65-3/8	3/8 O.D. ALUM ALLOY	3
TUBE ASSY	145H1402-31	BOOST RETURN #1	55	3/8 O.D. ALUM ALLOY	3
TUBE ASSY	145H1402-33	BOOST RETURN #2	50-1/2	3/8 O.D. ALUM ALLOY	3
TUBE ASSY	145H1801-1	BOOST PRESS #1	13-5/8	3/8 O.D. CRES STEEL	1, 2
TUBE ASSY	145H1801-3	BOOST PRESS #2	18-5/8	3/8 O.D. CRES STEEL	1, 2
TUBE ASSY	145H1801-5	UTILITY PRESS	32-1/4	3/8 O.D. CRES STEEL	1, 2
TUBE ASSY	145H1801-7	BRAKE PRESS	22-5/8	3/8 O.D. CRES STEEL	1, 2
TUBE ASSY	145H1801-9	BRAKE	22	3/8 O.D. CRES STEEL	1, 2
TUBE ASSY	145H1801-13	BRAKE	61-11/16	3/8 O.D. CRES STEEL	1, 2
TUBE ASSY	145H1801-15	BRAKE	26-3/8	3/8 O.D. CRES STEEL	1, 2
TUBE ASSY	145H1801-17	BRAKE	26-9/16	3/8 O.D. CRES STEEL	1, 2
TUBE ASSY	145H1801-19	BRAKE	36-3/4	3/8 O.D. CRES STEEL	1, 2
TUBE ASSY	145H1801-21	BRAKE	35-3/4	1/4 O.D. CRES STEEL	1, 2
TUBE ASSY	145H1801-23	UTILITY PRESS	18-3/4	3/8 O.D. CRES STEEL	1, 2
TUBE	145H1801-25	UTILITY PRESS	27	1/4 O.D. CRES STEEL	1, 2
TUBE	145H1801-27	UTILITY PRESS	48-3/4	1/4 O.D. CRES STEEL	1, 2

A. Tube Fabrication Data SHEET 7 OF 13

NOMENCLATURE	PART NUMBER	FUNCTION	FINISHED LENGTH ALONG TUBE C/L	MATERIAL	NOTES
TUBE	145H1801-29	UTILITY PRESS	34-15/16	1/4 O.D. CRES STEEL	1, 2
TUBE	145H1801-31	UTILITY PRESS	63-7/8	1/4 O.D. CRES STEEL	1, 2
TUBE	145H1801-33	UTILITY PRESS	44	1/4 O.D. CRES STEEL	1, 2
TUBE	145H1801-35	UTILITY PRESS	30	1/4 O.D. CRES STEEL	1, 2
TUBE	145H1801-37	UTILITY PRESS	9-1/8	1/4 O.D. CRES STEEL	1, 2
TUBE	145H1801-40	RAMP UP	34-5/8	1/4 O.D. CRES STEEL	1, 2
TUBE ASSY	145H1801-41	RAMP UP	13-1/8	1/4 O.D. CRES STEEL	1, 2
TUBE	145H1801-44	RAMP UP	35-7/8	1/4 O.D. CRES STEEL	1, 2
TUBE ASSY	145H1801-45	SWIVEL LOCK	105-1/8	1/4 O.D. CRES STEEL	1, 2
TUBE ASSY	145H1801-47	SWIVEL UNLOCK	105-1/8	1/4 O.D. CRES STEEL	1, 2
TUBE ASSY	145H1801-49	RAMP UP	13	1/4 O.D. CRES STEEL	1, 2
TUBE	145H1801-52	RAMP UP	35-11/16	1/4 O.D. CRES STEEL	1, 2
TUBE	145H1801-54	SWIVEL UNLOCK	19-1/2	1/4 O.D. CRES STEEL	1, 2
TUBE ASSY	145H1801-55	SWIVEL UNLOCK	10-1/2	1/4 O.D. CRES STEEL	1, 2
TUBE ASSY	145H1801-57	SWIVEL UNLOCK	33-13/16	1/4 O.D. CRES STEEL	1, 2
TUBE ASSY	145H1801-59	SWIVEL UNLOCK	17-5/16	1/4 O.D. CRES STEEL	1, 2
TUBE ASSY	145H1801-61	SWIVEL UNLOCK	17-7/8	1/4 O.D. CRES STEEL	1, 2
TUBE ASSY	145H1801-63	SWIVEL UNLOCK	5-5/16	1/4 O.D. CRES STEEL	1, 2
TUBE ASSY	145H1801-65	SWIVEL LOCK	15-9/16	3/8 O.D. CRES STEEL	1, 2
TUBE ASSY	145H1801-67	SWIVEL LOCK	11-3/4	1/4 O.D. CRES STEEL	1, 2
TUBE	145H1801-70	SWIVEL LOCK	34-15/16	1/4 O.D. CRES STEEL	1, 2
TUBE ASSY	145H1801-71	SWIVEL LOCK	14-3/8	1/4 O.D. CRES STEEL	1, 2
TUBE ASSY	145H1801-73	SWIVEL LOCK	15-1/8	1/4 O.D. CRES STEEL	1, 2
TUBE ASSY	145H1801-75	SWIVEL LOCK	8-1/4	1/4 O.D. CRES STEEL	1, 2
TUBE ASSY	145H1801-77	POWER STEERING	20-5/8	1/4 O.D. CRES STEEL	1, 2
TUBE ASSY	145H1801-79	UTILITY PRESS	37-5/8	3/4 O.D. CRES STEEL	1, 2
TUBE ASSY	145H1801-81	START PRESS	20	3/4 O.D. CRES STEEL	1, 2
TUBE ASSY	145H1801-83	PRESS	14-7/8	1/4 O.D. CRES STEEL	1, 2
TUBE ASSY	145H1801-85	RAMP UNLOCK	13	1/4 O.D. CRES STEEL	1, 2
TUBE	145H1801-88	RAMP UNLOCK	31-5/8	1/4 O.D. CRES STEEL	1, 2
TUBE ASSY	145H1801-89	RAMP UNLOCK	20-3/16	1/4 O.D. CRES STEEL	1, 2
TUBE ASSY	145H1801-91	RAMP UP	9-1/4	1/4 O.D. CRES STEEL	1, 2
TUBE ASSY	145H1801-93	PRESS	26-1/16	1/4 O.D. CRES STEEL	1, 2
TUBE ASSY	145H1801-95	ACCUMULATOR	10-7/16	1/4 O.D. CRES STEEL	1, 2
TUBE ASSY	145H1801-97	POWER STEERING	28	1/4 O.D. CRES STEEL	1, 2

A. Tube Fabrication Data SHEET 8 OF 13

NOMENCLATURE	PART NUMBER	FUNCTION	FINISHED LENGTH ALONG TUBE C/L	MATERIAL	NOTES
TUBE ASSY	145H1801-99	ENG START PRESS	17	5/8 O.D. CRES STEEL	1, 2
TUBE ASSY	145H1801-101	BRAKE	39-9/16	1/4 O.D. CRES STEEL	1, 2
TUBE ASSY	145H1801-103	BRAKE	8-3/16	1/4 O.D. CRES STEEL	1, 2
TUBE	145H1801-106	BRAKE	58-7/8	1/4 O.D. CRES STEEL	1, 2
TUBE ASSY	145H1801-107	UTILITY PRESS	35-5/8	3/8 O.D. CRES STEEL	1, 2
TUBE ASSY	145H1801-111	RAMP DOOR CLOSE	8-7/8	1/4 O.D. CRES STEEL	1, 2
TUBE ASSY	145H1801-113	RAMP DOOR OPEN	9-3/8	1/4 O.D. CRES STEEL	1, 2
TUBE ASSY	145H1801-131	BOOST PRESS #2	37	1/2 O.D. CRES STEEL	1, 2
TUBE ASSY	145H1801-135	PRESS	25-5/8	3/8 O.D. CRES STEEL	1, 2
TUBE ASSY	145H1801-141	UTILITY PRESS	45-1/2	3/8 O.D. CRES STEEL	1, 2
TUBE ASSY	145H1801-143	UTILITY PRESS	46-1/4	3/8 O.D. CRES STEEL	1, 2
TUBE ASSY	145H1801-145	PRESS	33	1/4 O.D. CRES STEEL	1, 2
TUBE	145H1801-150	PRESS	29-15/16	1/4 O.D. CRES STEEL	1, 2
TUBE	145H1801-152	ACCUMULATOR PRESS	21	3/4 O.D. CRES STEEL	1, 2
TUBE ASSY	145H1801-153	UTILITY PRESS	56-1/4	1/4 O.D. CRES STEEL	1, 2
TUBE	145H1801-156	UTILITY PRESS	27-7/8	1/4 O.D. CRES STEEL	1, 2
TUBE ASSY	145H1801-157	UTILITY PRESS	23	1/4 O.D. CRES STEEL	1, 2
TUBE	145H1801-160	ENG START PRESS	12-1/2	5/8 O.D. CRES STEEL	1, 2
TUBE ASSY	145H1801-161	ENG START PRESS	41-3/4	5/8 O.D. CRES STEEL	1, 2
TUBE ASSY	145H1801-163	ENG START PRESS	50-1/2	5/8 O.D. CRES STEEL	1, 2
TUBE ASSY	145H1801-165	ENG START PRESS	17-1/4	5/8 O.D. CRES STEEL	1, 2
TUBE ASSY	145H1801-167	RAMP DOWN	17-1/16	1/4 O.D. CRES STEEL	1, 2
TUBE ASSY	145H1801-169	RAMP DOWN	34-3/8	1/4 O.D. CRES STEEL	1, 2
TUBE ASSY	145H1801-171	BOOST PRESS #2	26	1/2 O.D. CRES STEEL	1, 2
TUBE ASSY	145H1801-173	BOOST PRESS #2	47-1/16	1/2 O.D. CRES STEEL	1, 2
TUBE ASSY	145H1801-175	UTILITY PRESS	13-3/4	3/8 O.D. CRES STEEL	1, 2
TUBE ASSY	145H1801-177	ENG START PRESS	44-1/4	5/8 O.D. CRES STEEL	1, 2
TUBE	145H1801-180	ENG START PRESS	10-5/8	5/8 O.D. CRES STEEL	1, 2
TUBE ASSY	145H1801-181	RAMP UP	105-1/8	1/4 O.D. CRES STEEL	1, 2
TUBE ASSY	145H1801-183	UTILITY PRESS	18-5/8	1/4 O.D. CRES STEEL	1, 2
TUBE ASSY	145H1801-187	RAMP UNLOCK	105-1/8	1/4 O.D. CRES STEEL	1, 2
TUBE ASSY	145H1801-191	RAMP UNLOCK	20-1/16	1/4 O.D. CRES STEEL	1, 2
TUBE	145H1801-196	RAMP UNLOCK	34-5/16	1/4 O.D. CRES STEEL	1, 2

A. Tube Fabrication Data SHEET 9 OF 13

NOMENCLATURE	PART NUMBER	FUNCTION	FINISHED LENGTH ALONG TUBE C/L	MATERIAL	NOTES
TUBE ASSY	145H1801-197	UTILITY PRESS	51	1/2 O.D. CRES STEEL	1, 2
TUBE ASSY	145H1801-199	UTILITY PRESS	71-3/4	1/2 O.D. CRES STEEL	1, 2
TUBE ASSY	145H1801-201	UTILITY PRESS	11-3/4	1/2 O.D. CRES STEEL	1, 2
TUBE	145H1801-206	RAMP DOOR CLOSE	36	1/4 O.D. CRES STEEL	1, 2
TUBE	145H1801-208	RAMP DOOR OPEN	38	1/4 O.D. CRES STEEL	1, 2
TUBE ASSY	145H1801-211	RAMP DOOR CLOSE	32-1/2	1/4 O.D. CRES STEEL	1, 2
TUBE ASSY	145H1801-213	RAMP DOOR OPEN	31-3/4	1/4 O.D. CRES STEEL	1, 2
TUBE ASSY	145H1801-215	SWIVEL UNLOCK	15-5/8	1/4 O.D. CRES STEEL	1, 2
TUBE ASSY	145H1801-217	SWIVEL LOCK	15-5/8	1/4 O.D. CRES STEEL	1, 2
TUBE ASSY	145H1801-219	BRAKE	15-5/8	1/4 O.D. CRES STEEL	1, 2
TUBE ASSY	145H1801-221	SWIVEL LOCK	10-5/8	1/4 O.D. CRES STEEL	1, 2
TUBE ASSY	145H1801-223	BRAKE	21-3/16	1/4 O.D. CRES STEEL	1, 2
TUBE ASSY	145H1801-225	BRAKE	17-1/8	1/4 O.D. CRES STEEL	1, 2
TUBE ASSY	145H1801-227	SWIVEL LOCK	19-1/4	1/4 O.D. CRES STEEL	1, 2
TUBE ASSY	145H1801-229	SWIVEL UNLOCK	19-1/2	1/4 O.D. CRES STEEL	1, 2
TUBE ASSY	145H1801-231	BRAKE	14-7/8	1/4 O.D. CRES STEEL	1, 2
TUBE ASSY	145H1801-233	SWIVEL LOCK	10-5/8	1/4 O.D. CRES STEEL	1, 2
TUBE ASSY	145H1801-235	UTILITY PRESS	19-3/8	1/2 O.D. CRES STEEL	1, 2
TUBE ASSY	145H1801-237	UTILITY PRESS	14-1/8	3/8 O.D. CRES STEEL	1, 2
TUBE ASSY	145H1801-239	UTILITY PRESS	21-3/16	3/4 O.D. CRES STEEL	1, 2
TUBE ASSY	145H1801-241	UTILITY PRESS	28-1/4	3/4 O.D. CRES STEEL	1, 2
TUBE ASSY	145H1801-243	UTILITY PRESS	39-7/8	3/4 O.D. CRES STEEL	1, 2
TUBE ASSY	145H1801-245	BOOST PRESS #2	32	1/2 O.D. CRES STEEL	1, 2
TUBE ASSY	145H1801-247	RAMP DOWN	14-7/8	1/4 O.D. CRES STEEL	1, 2
TUBE	145H1801-250	RAMP DOWN	30-3/4	1/4 O.D. CRES STEEL	1, 2
TUBE ASSY	145H1801-251	RAMP DOWN	17-7/16	1/4 O.D. CRES STEEL	1, 2
TUBE ASSY	145H1801-253	RAMP DOWN	105-1/8	1/4 O.D. CRES STEEL	1, 2
TUBE	145H1801-256	BOOST PRESS #1	18-7/8	3/8 O.D. CRES STEEL	1, 2
TUBE ASSY	145H1801-257	BOOST PRESS #1	65	3/8 O.D. CRES STEEL	1, 2
TUBE ASSY	145H1801-261	BOOST PRESS #1	28-1/16	3/8 O.D. CRES STEEL	1, 2
TUBE ASSY	145H1801-263	BOOST PRESS #1	39-1/8	3/8 O.D. CRES STEEL	1, 2
TUBE ASSY	145H1801-267	BOOST PRESS #2	8-11/16	1/4 O.D. CRES STEEL	1, 2
TUBE ASSY	145H1801-269	BOOST PRESS #2	10-15/16	3/8 O.D. CRES STEEL	1, 2
TUBE ASSY	145H1801-271	BOOST PRESS #2	49-1/2	3/8 O.D. ORES STEEL	1, 2

A. Tube Fabrication Data SHEET 10 OF 13

NOMENCLATURE	PART NUMBER	FUNCTION	FINISHED LENGTH ALONG TUBE C/L	MATERIAL	NOTES
TUBE ASSY	145H1802-1	BOOST RETURN #1	17	3/8 O.D. ALUM ALLOY	3
TUBE ASSY	145H1802-3	BOOST RETURN #2	17-5/8	3/8 O.D. ALUM ALLOY	3
TUBE ASSY	145H1802-5	RETURN	33-7/8	1/2 O.D. ALUM ALLOY	3
TUBE ASSY	145H1802-7	UTILITY RETURN	16	3/8 O.D. ALUM ALLOY	3
TUBE ASSY	145H1802-9	UTILITY RETURN	17-3/4	3/8 O.D. ALUM ALLOY	3
TUBE ASSY	146H1802-11	UTILITY RETURN	36-15/16	3/8 O.D. ALUM ALLOY	3
TUBE	145H1802-14	RESERVOIR FILL	18-5/8	1/4 O.D. CRES STEEL	1, 2
TUBE ASSY	145H1802-15	UTILITY RETURN	34-1/4	5/8 O.D. ALUM ALLOY	3
TUBE ASSY	145H1802-17	UTILITY RETURN	15-1/4	3/8 O.D. ALUM ALLOY	3
TUBE	145H1802-20	OVERBOARD DRAIN	36-1/16	3/8 O.D. ALUM ALLOY	3
TUBE	145H1802-22	OVERBOARD DRAIN	43-3/16	3/8 O.D. ALUM ALLOY	3
TUBE	145H1802-24	OVERBOARD DRAIN	35	3/8 O.D. ALUM ALLOY	3
TUBE ASSY	145H1802-25	OVERBOARD DRAIN	25-1/2	3/8 O.D. ALUM ALLOY	3
TUBE ASSY	145H1802-27	PWR STRG RETURN	9	3/8 O.D. CRES STEEL	1, 2
TUBE ASSY	145H1802-29	UTILITY RETURN	34	3/8 O.D. ALUM ALLOY	3
TUBE ASSY	145H1802-33	RAMP RETURN	21	3/8 O.D. ALUM ALLOY	3
TUBE ASSY	145H1802-35	UTILITY RETURN	15-5/8	5/8 O.D. ALUM ALLOY	3
TUBE	145H1802-38	UTILITY RETURN	23	5/8 O.D. ALUM ALLOY	3
TUBE	145H1802-40	PUMP SUCTION	27-5/8	3/8 O.D. ALUM ALLOY	3
TUBE ASSY	145H1802-41	ENG START RETURN	28-3/4	3/4 O.D. ALUM ALLOY	3
TUBE ASSY	145H1802-43	ENG START RETURN	37-1/2	3/4 O.D. ALUM ALLOY	3
TUBE ASSY	145H1802-45	ENG START RETURN	25-5/8	3/4 O.D. ALUM ALLOY	3
TUBE ASSY	145H1802-47	ENG START RETURN	55-3/8	3/4 O.D. ALUM ALLOY	3
TUBE ASSY	145H1802-49	ENG START RETURN	29-1/2	3/4 O.D. ALUM ALLOY	3
TUBE ASSY	145H1802-51	OVERBOARD DRAIN	15-1/4	1/2 O.D. ALUM ALLOY	3
TUBE ASSY	145H1802-53	BOOST RETURN #2	36	5/8 O.D. ALUM ALLOY	3
TUBE ASSY	145H1802-55	BOOST RETURN #2	31-1/2	5/8 O.D. ALUM ALLOY	3
TUBE ASSY	145H1802-57	BOOST RETURN #2	43-1/8	5/8 O.D. ALUM ALLOY	3

A. Tube Fabrication Data SHEET 11 OF 13

NOMENCLATURE	PART NUMBER	FUNCTION	FINISHED LENGTH ALONG TUBE C/L	MATERIAL	NOTES
TUBE	145H1802-60	OVERBOARD DRAIN	52	1/2 O.D. ALUM ALLOY	3
TUBE	145H1802-62	OVERBOARD DRAIN	8-5/8	1/2 O.D. ALUM ALLOY	3
TUBE ASSY	145H1802-67	SUCTION	50-3/8	3/8 O.D. ALUM ALLOY	3
TUBE	145H1802-70	OVERBOARD DRAIN	46-7/8	1/2 O.D. ALUM ALLOY	3
TUBE ASSY	145H1802-71	UTILITY RETURN	18-1/4	3/4 O.D. ALUM ALLOY	3
TUBE ASSY	145H1802-73	UTILITY RETURN	36-3/4	3/8 O.D. ALUM ALLOY	3
TUBE ASSY	145H1802-75	CASE DRAIN	14-3/16	1/2 O.D. ALUM ALLOY	3
TUBE ASSY	145H1802-77	CASE DRAIN	9-5/16	1/2 O.D. ALUM ALLOY	3
TUBE ASSY	145H1802-79	UTILITY RETURN	14-3/8	5/8 O.D. ALUM ALLOY	3
TUBE ASSY	145H1802-81	UTILITY RETURN	24-1/2	5/8 O.D. ALUM ALLOY	3
TUBE ASSY	145H1602-83	UTILITY RETURN	23	1 O.D. ALUM ALLOY	3
TUBE	145H1802-86	PUMP SUCTION	34-1/4	1 O.D. ALUM ALLOY	3
TUBE ASSY	145H1802-87	CASE DRAIN	20-7/16	3/8 O.D. ALUM ALLOY	3
TUBE ASSY	145H1802-89	CASE DRAIN	49	3/8 O.D. ALUM ALLOY	3
TUBE ASSY	145H1802-91	PUMP SUCTION	30-3/8	3/4 O.D. ALUM ALLOY	3
TUBE ASSY	145H1802-93	OVERBOARD DRAIN	4-1/2	1/4 O.D. ALUM ALLOY	3
TUBE ASSY	145H1802-97	BOOST RETURN #1	15-9/16	3/6 O.D. ALUM ALLOY	3
TUBE ASSY	145H1802-99	BOOST RETURN #1	61	3/8 O.D. ALUM ALLOY	3
TUBE ASSY	145H1802-103	BOOST RETURN #1	28-1/8	3/8 O.D. ALUM ALLOY	3
TUBE ASSY	145H1802-105	BOOST RETURN #1	29-3/16	3/8 O.D. ALUM ALLOY	3
TUBE ASSY	145H1802-107	BOOST RETURN #2	50-9/16	3/8 O.D. ALUM ALLOY	3
TUBE ASSY	145H1802-109	BOOST RETURN #2	11	3/8 O.D. ALUM ALLOY	3
TUBE ASSY	145H1802-111	PWR STRG RETURN	22-1/4	1/4 O.D. CRES STEEL	1, 2
TUBE ASSY	145H1802-117	RETURN	7-1/4	1/4 O.D. CRES STEEL	1, 2
TUBE ASSY	145H1802-119	RETURN	13	1/4 O.D. CRES STEEL	1, 2
TUBE	145H1802-122	RAMP RETURN	3-3/16	1/4 O.D. CRES STEEL	1, 2
TUBE ASSY	145H1802-123	RETURN	65-11/16	1/4 O.D. CRES STEEL	1, 2
TUBE ASSY	145H1802-125	RETURN	42-7/8	1/4 O.D. CRES STEEL	1, 2
TUBE ASSY	145H1802-127	RETURN	22-1/2	1/4 O.D. CRES STEEL	1, 2
TUBE ASSY	145H1802-129	RETURN	30-3/16	1/4 O.D. CRES STEEL	1, 2

A. Tube Fabrication Data SHEET 12 OF 13

NOMENCLATURE	PART NUMBER	FUNCTION	FINISHED LENGTH ALONG TUBE C/L	MATERIAL	NOTES
TUBE ASSY	145H1802-133	RESERVOIR FILL #1	22-3/4	1/4 O.D. CRES STEEL	1, 2
TUBE	145H1802-136	RESERVOIR FILL #1	42	1/4 O.D. CRES STEEL	1, 2
TUBE ASSY	145H1802-137	RESERVOIR FILL #1	35-7/8	1/4 O.D. CRES STEEL	1, 2
TUBE ASSY	145H1802-139	RESERVOIR FILL #1	34	1/4 O.D. CRES STEEL	1, 2
TUBE ASSY	145H1802-141	RESERVOIR FILL #2	62-3/4	1/4 O.D. CRES STEEL	1, 2
TUBE ASSY	145H1802-143	RESERVOIR FILL #2	31	1/4 O.D. CRES STEEL	1, 2
TUBE ASSY	145H1802-147	RESERVOIR FILL	23-7/8	1/4 O.D. CRES STEEL	1, 2
TUBE ASSY	145H1802-149	OVERBOARD DRAIN	27-1/8	1/4 O.D. CRES STEEL	1, 2
TUBE ASSY	145H1802-151	OVERBOARD DRAIN	18-1/8	1/4 O.D. ALUM ALLOY	3
TUBE ASSY	145H1802-153	OVERBOARD DRAIN	38-9/16	1/4 O.D. CRES STEEL	1, 2
TUBE	145H1802-164	RETURN	38-1/2	1/4 O.D. CRES STEEL	1, 2
TUBE ASSY	145H1802-165	RETURN	31-1/4	1/4 O.D. CRES STEEL	1, 2
TUBE ASSY	145H1802-167	BOOST RETURN #1	19-1/8	1/4 O.D. CRES STEEL	1, 2
TUBE ASSY	145H1802-169	BOOST RETURN #2	18-15/16	1/4 O.D. CRES STEEL	1, 2
TUBE ASSY	145H1802-171	BOOST RETURN #1	19-1/16	1/4 O.D. CRES STEEL	1, 2
TUBE ASSY	145H1802-173	BOOST RETURN #2	18-3/4	1/4 O.D. CRES STEEL	1, 2
TUBE ASSY	145H1802-175	RETURN	19-1/2	1 O.D. ALUM ALLOY	3
TUBE ASSY	145H1802-177	SUCTION	29-1/2	1 O.D. ALUM ALLOY	3
TUBE ASSY	145H1802-179	SUCTION	16-1/4	3/8 O.D. ALUM ALLOY	3
TUBE ASSY	145H1802-181	RETURN	10-1/8	1 O.D. ALUM ALLOY	3
TUBE ASSY	145H1802-183	CASE DRAIN	28-7/8	3/8 O.D. ALUM ALLOY	3
TUBE	145H1802-186	CASE DRAIN	47-7/8	3/8 O.D. ALUM ALLOY	3
TUBE ASSY	145H1802-189	UTILITY RETURN	25-3/4	3/8 O.D. ALUM ALLOY	3
TUBE ASSY	145H1802-191	UTILITY RETURN	22-7/8	5/8 O.D. ALUM ALLOY	3
TUBE ASSY	145H1802-193	POWER STEERING RETURN	22	1/4 O.D. CRES STEEL	1, 2
TUBE ASSY	145H1802-197	ENG START RETURN	7-1/8	3/4 O.D. ALUM ALLOY	3
TUBE	145H1802-200	RETURN	36-3/4	5/8 O.D. ALUM ALLOY	3
TUBE ASSY	145H1803-1	PRESSURE	14	1/2 O.D. CRES STEEL	1, 2

A. Tube Fabrication Data SHEET 13 OF 13

NOMENCLATURE	PART NUMBER	FUNCTION	FINISHED LENGTH ALONG TUBE C/L	MATERIAL	NOTES
TUBE	145H1803-6	UTILITY PRESS	20-5/8	1/4 O.D. CRES STEEL	1, 2
TUBE	145H1803-8	UTILITY PRESS	21-3/8	1/4 O.D. CRES STEEL	1, 2
TUBE ASSY	145H1803-11	PRESS	45-3/4	1/2 O.D. CRES STEEL	1, 2
TUBE	145H1803-14	PRESS	18	3/8 O.D. CRES STEEL	1, 2
TUBE ASSY	145H1803-15	PRESS	68-1/2	1/4 O.D. CRES STEEL	1, 2
TUBE ASSY	145H1803-17	BOOST PRESS #2	30-7/16	1/2 O.D. CRES STEEL	1, 2
TUBE ASSY	145H1803-23	PRESS	13-1/8	1/2 O.D. CRES STEEL	1, 2
TUBE ASSY	145H1803-25	BOOST PRESS #1	71-1/8	3/8 O.D. CRES STEEL	1, 2
TUBE ASSY	145H1803-27	BOOST PRESS #2	70	3/8 O.D. CRES STEEL	1, 2
TUBE ASSY	145H1804-1	RETURN	10-1/4	1/2 O.D. ALUM ALLOY	3
TUBE ASSY	145H1804-3	UTILITY RETURN	25-3/4	3/4 O.D. ALUM ALLOY	3
TUBE ASSY	145H1804-5	BOOST RETURN #2	41-1/8	1/2 O.D. ALUM ALLOY	3
TUBE ASSY	145H1804-7	BOOST RETURN #2	28-15/16	1/2 O.D. ALUM ALLOY	3
TUBE	145H1804-10	RETURN	61-1/8	3/4 O.D. ALUM ALLOY	3
TUBE	145H1804-12	UTILITY RETURN	11-1/2	3/4 O.D. ALUM ALLOY	3
TUBE ASSY	145H1804-21	BOOST SUCTION	49-5/8	1 O.D. ALUM ALLOY	3
TUBE	145H1804-24	RETURN	29-1/4	5/8 O.D. ALUM ALLOY	3
TUBE ASSY	145H1804-25	DRAIN	3-1/4	3/8 O.D. ALUM ALLOY	3
TUBE ASSY	145H1804-27	BOOST RETURN #1	68-1/2	3/8 O.D. ALUM ALLOY	3
TUBE ASSY	145H1804-29	BOOST RETURN #2	67-1/2	3/8 O.D. ALUM ALLOY	3
TUBE ASSY	145H1804-31	FILL	17-3/4	1/4 O.D. CRES STEEL	1, 2
TUBE ASSY	145H1804-33	CASE DRAIN	4	1/4 O.D. CRES STEEL	1, 2
TUBE ASSY	145H1804-35	CASE DRAIN	15-5/8	3/8 O.D. ALUM ALLOY	3

A: TUBE FABRICATION DATA (CONTINUED)**NOTES:**

- 21-6-9 Corrosion resistant steel tube. This is original material but is difficult to bend without distortion. It is best used in bending tubes up to **1/2 inch** diameter or in straight run tubing with no bends.

Wall Thickness 1/4 inch O.D. X 0.020 inch wall
 3/8 inch O.D. X 0.020 inch wall
 1/2 inch O.D. X 0.026 inch wall
 5/8 inch O.D. X 0.033 inch wall
 3/4 inch O.D. X 0.039 inch wall

- MIL-T-6845 corrosion resistant steel tube. This tubing is recommended for all field fabricated tubes and repair sections. This is an acceptable alternate to original tube material. (See note 1.)

Wall Thickness 1/4 inch O.D. X 0.028 inch wall (E429.1)
 3/8 inch O.D. X 0.028 inch wall (E429.2)
 1/2 inch O.D. X 0.042 inch wall (E429.3)
 5/8 inch O.D. X 0.049 inch wall (E429.4)
 3/4 inch O.D. X 0.049 inch wall (E429.5)

- 6061-T6 aluminum alloy tubing (MIL-T-7081, temp. T-6)

Wall Thickness 1/4 inch O.D. X 0.035 inch wall (E427.1)
 3/8 inch O.D. X 0.035 inch wall (E427.2)
 1/2 inch O.D. X 0.035 inch wall (E427.3)
 5/8 inch O.D. X 0.035 inch wall (E427.4)
 3/4 inch O.D. X 0.035 inch wall (E427.5)
 1 inch O.D. X 0.049 inch wall (E427.6)

- All dimensions are in inches.

B. Tube Bend Data SHEET 1 OF 13

Bend Data																	
PART NUMBER	FLOW REL TO X END	BEND 1				BEND 2				BEND 3				BEND 4			
		DIST FROM X END	RAD	DIAL H DEG BEND	DIAL C SET	DIST FROM X END	RAD	DIAL H DEG BEND	DIAL C SET	DIST FROM X END	RAD	DIAL H DEG BEND	DIAL C SET	DIST FROM X END	RAD	DIAL H DEG BEND	DIAL C SET
114E1042-418		STRAIGHT															
114E4048-125	FROM	9-7/8	1-1/4	80	0												
114E4048-151	—	3-3/8	1-1/4	85	85	4-15/16	1-1/4	30	240	6-15/16	1-1/4	55	0				
114P4302	TO	3-3/8	1	45	150	9-1/4	1	45	330	19-5/8	1	23	266	23-3/8	1	88	0
145H1301-1	—	18-3/4	1	90	0	12-1/2	1	90	200	2-3/16	1	48	292				
145H1301-3	—	18-1/2	1	90	0	13-3/8	1	90	200	2	1	48	292				
145H1301-6	—	8-3/4	1	28	0												
145H1301-7	—	13	1	90	0	2-1/4	1	49	0								
145H1301-9	—	25-13/16	1	90	0	20-5/8	1	15	180	17-1/2	1	95	270	3	1	30	345
145H1301-11	—	29-1/2	1	35	0	18-11/16	1	90	0	7	1	45	180	2-3/8	1	45	180
145H1301-13	—	3-1/4	1	134	0												
145H1301-15	—	3	1	90	0												
145H1301-17	—	22	1	61	0	13-1/2	1	79	176	9	1	92	79				
145H1301-21	FROM	7-5/8	1	30	0	5-3/4	1	30	180								
145H1301-23	TO	14-1/4	1-1/2	16	0	10-1/8	1-1/2	52	90								
145H1301-25	TO	4-1/2	1	36	0	2-3/4	1	36	180								
145H1301-27	-	7-7/8	1	25	0	3-1/8	1	90	180								
145H1301-30	FROM	16-1/4	1	90	0	3-1/8	1	90	0								
145H1301-31	-	5-15/16	1	90	0	2-1/2	1	11	84								
145H1301-33	TO	STRAIGHT															
145H1301-35	FROM	27-7/8	1-3/4	90	0	17-3/16	1-3/4	90	0	4-5/8	1-3/4	25	2				
145H1301-38	TO	9-1/16	1	39	0	4-9/16	1	75	180								
145H1301-39	FROM	9-11/16	1-1/2	163	0	4-1/16	1-1/2	17	0								
145H1301-42	FROM	5-5/8	1	58	0	2-5/16	1	58	130								
145H1301-45	—	30-5/8	1	90	0	22-3/8	1	104	180								
145H1301-47	—	29	1	23	0	24-1/4	1	108	90	20-1/8	1	28	180	4-3/4	1	12	180
145H1301-52	TO	49-3/16	1-1/2	90	0	43-7/8	1-1/2	90	180	31-3/8	1-1/2	90	344	32-7/8	1-1/2	92	257
145H1301-53	—	76-1/8	1	90	0	72-1/2	1	85	0	58-1/2	1	96	230	52-3/4	1	5	322
145H1301-55	—	74	1	45	0	71	1	45	180	55-3/4	1	94	90	45-3/4	1	90	0
145H1301-59	FROM	78-3/4	1-1/2	73	0	76	1-1/2	73	180	58-1/2	1-1/2	94	90	47	1-1/2	90	0
145H1301-61	TO	56-3/8	1-1/2	98	0	42-1/2	1-1/2	75	90	21-7/8	1-1/2	75	134	11-7/8	1-1/2	90	58
145H1301-64	FROM	32-1/2	1-1/2	34	0	30-1/2	1-1/2	34	180	24-1/2	1-1/2	90	180	15-7/16	1-1/2	12	90
145H1301-65	TO	STRAIGHT															
145H1301-68	FROM	45-7/8	1-1/2	6	0	21-3/4	1-1/2	93	180								

B. Tube Bend Data SHEET 1 OF 13

BEND DATA																	
PART NUMBER	FLOW REL TO X END	BEND 5				BEND 6				BEND 7				BEND 8			
		DIST FROM X END	RAD	DIAL H DEG BEND	DIAL C SET	DIST FROM X END	RAD	DIAL H DEG BEND	DIAL C SET	DIST FROM X END	RAD	DIAL H DEG BEND	DIAL C SET	DIST FROM X END	RAD	DIAL H DEG BEND	DIAL C SET
145H1301-47	—	3-1/8	1	12	0												
145H1301-52	TO	13-7/16	1-1/2	90	311												
145H1301-53	—	43-11/16	1	90	140	14-5/8	1	76	235	7-1/4	1	92	322				
145H1301-55	—	21	1	90	0	11-1/2	1	45	270	7-5/8	1	45	270	4	1	90	180
145H1301-59	FROM	21-1/2	1-1/2	90	0	10	1-1/2	98	270	5-5/8	1-1/2	88	186				
145H1301-61	TO	3-3/4	1-1/2	90	235												
145H1301-64	FROM	6	1-1/2	7	90												

B. Tube Bend Data SHEET 2 OF 13

Bend Data																	
PART NUMBER	FLOW REL TO X END	BEND 1				BEND 2				BEND 3				BEND 4			
		DIST FROM X END	RAD	DIAL H DEG BEND	DIAL C SET	DIST FROM X END	RAD	DIAL H DEG BEND	DIAL C SET	DIST FROM X END	RAD	DIAL H DEG BEND	DIAL C SET	DIST FROM X END	RAD	DIAL H DEG BEND	DIAL C SET
145H1301-74	TO	68-1/2	1-1/2	70	0	44-15/16	1-1/2	11	265	34-7/8	1-1/2	87	265	14-1/2	1-1/2	90	193
145H1301-75	FROM	STRAIGHT															
145H1301-78	TO	7-5/8	1-1/2	26	0					2-9/16	1-1/2	26	180				
145H1301-80	TO	4-1/8	1-1/2	45	0												
145H1301-81	TO	20-9/16	1	31	0	19-1/16	1	33	180	17-3/4	1	98	270	13-11/16	1	29	55
145H1301-83	TO	19-1/4	1	60	0	17-1/8	1	62	180	12-5/16	1	90	305	9	1	50	125
145H1301-86	FROM	36-5/8	1	62	0	35	1	90	270	19-3/16	1	90	90	11-5/8	1	31	0
145H1301-88	FROM	34-1/16	1	26	0	33	1	26	180	31-3/4	1	90	270	28	1	90	180
145H1301-89	FROM	20-13/16	1-3/4	90	0	12-7/8	1-3/4	90	262	7-9/16	1-3/4	75	172				
145H1301-91	TO	37-3/4	1-1/2	20	0	35-3/4	1-1/2	27	180	20-1/8	1-1/2	22	180	18-5/8	1-1/2	90	270
145H1301-93	TO	3-1/2	1-1/4	90	0												
145H1301-95	—	33-1/4	1	40	0	31	1	40	195	13-3/8	1	9	170	7-1/4	1	90	267
145H1301-97	FROM	22-3/4	1-1/2	55	0	19	1-1/2	58	180								
145H1301-99	—	83-3/4	1	95	0	70-1/2	1	60	0	61-3/4	1	90	101	39-1/4	1	90	306
145H1301-101	—	42-5/8	1	85	0	34-1/4	1	2	90	23-1/2	1	16	90	4-1/2	1	16	90
145H1301-103	—	31-1/2	1	23	0	29-5/8	1	23	180	4-1/8	1	23	160	1-1/2	1	23	340
145H1301-105	FROM	19	1-1/2	19	0	17-1/8	1-1/2	90	90	3-7/16	1-1/2	92	342				
145H1301-115	FROM	10-3/8	1-1/2	55	0	6-7/8	1-1/2	51	180								
145H1301-117	TO	16-15/16	2	15	0	8-7/8	2	28	280								
145H1301-119	FROM	46-7/16	1-1/2	90	0	40-5/8	1-1/2	90	270	34-3/8	1-1/2	90	90	26-3/8	1-1/2	60	90
145H1301-121	TO	36-7/16	1-1/2	38	0	33-5/8	1-1/2	38	180	19-1/2	1-1/2	50	315	15-11/16	1-1/2	10	50
145H1301-123	TO	10-3/4	1-1/2	15	0	4-3/16	1-1/2	19	260								
145H1301-125	TO	45-1/4	1-1/2	30	0	41-5/8	1-1/2	90	270	35-3/8	1-1/2	90	90	28	1-1/2	43	90
145H1301-127	FROM	50-5/8	2	90	0	42-5/8	2	43	48	32-13/16	2	29	320	21-7/8	2	46	63
145H1301-129	TO	15-1/4	2	90	0												
145H1301-131	TO	40-5/8	2	12	0	30-1/2	2	18	0	20-1/8	2	44	0	5-3/4	2	88	90
145H1301-133	FROM	31-1/4	1-3/4	10	0	6	1-3/4	22	0	3-1/4	1-3/4	22	180				
145H1301-136	TO	44-5/8	1-1/2	180	0	37-3/4	1-1/2	90	95	30-11/16	1-1/2	45	250	22-1/4	1-1/2	60	48
145H1301-137	FROM	23-13/16	1	18	0	19-1/2	1	43	340	15	1	45	125	9-3/4	1	40	235
145H1301-139	TO	13-3/4	2	66	0	9-9/16	2	12	90								
145H1301-141	FROM	40-1/4	1-1/2	80	0	34-1/2	1-1/2	80	180	5-3/4	1-1/2	90	0				
145H1301-143	—	35-1/4	1	24	0	29-1/2	1	34	180	24-1/2	1	90	90				
145H1301-146	—	24	1	41	0	20-5/8	1	41	180	17-1/4	1	65	7	10-1/4	1	65	192
145H1301-151	FROM	24-5/8	1	30	0	21	1	30	180	11-3/16	1	23	172	5-3/8	1	27	262

B. Tube Bend Data SHEET 2 OF 13

BEND DATA																	
PART NUMBER	FLOW REL TO X END	BEND 5				BEND 6				BEND 7				BEND 8			
		DIST FROM X END	RAD	DIAL H DEG BEND	DIAL C SET	DIST FROM X END	RAD	DIAL H DEG BEND	DIAL C SET	DIST FROM X END	RAD	DIAL H DEG BEND	DIAL C SET	DIST FROM X END	RAD	DIAL H DEG BEND	DIAL C SET
145H1301-74	TO	8-1/2	1-1/2	90	13												
145H1301-81	TO	4-5/8	1	90	355												
145H1301-83	TO	3-5/8	1	40	135												
145H1301-86	FROM	7-9/16	1	59	0	2-5/8	1	90	208								
145H1301-88	FROM	13-5/16	1	90	180	5-15/16	1	50	266	3-3/16	1	65	104				
145H1301-91	TO	6	1-1/2	90	151												
145H1301-119	FROM	19-3/1	1-1/2	90	180												
145H1301-121	TO	9-13/16	1-1/2	50	142												
145H1301-125	TO	19	1-1/2	90	181	7-5/8	1-1/2	63	205	4-1/2	1-1/2	79	15				
145H1301-127	FROM	6-7/8	2	54	302												
145H1301-136	TO	16-7/8	1-1/2	80	325	3-13/16	1-1/2	90	20								
145H1301-137	FROM	5-7/16	1	38	55	2-5/8	1	90	147								

B. Tube Bend Data SHEET 3 OF 13

Bend Data																	
PART NUMBER	FLOW REL TO X END	BEND 1				BEND 2				BEND 3				BEND 4			
		DIST FROM X END	RAD	DIAL H DEG BEND	DIAL C SET	DIST FROM X END	RAD	DIAL H DEG BEND	DIAL C SET	DIST FROM X END	RAD	DIAL H DEG BEND	DIAL C SET	DIST FROM X END	RAD	DIAL H DEG BEND	DIAL C SET
145H1301-155	FROM	8-3/4	1-1/4	60	0	3-15/16	1-1/4	110	253								
145H1301-158	FROM	5-1/2	1-1/4	20	0	2-15/16	1-1/4	86	30								
145H1301-160	TO	9-1/16	1-1/4	20	0	3-15/16	1-1/4	20	180								
145H1301-161	FROM	19-5/8	1-1/2	90	0	12-5/16	1-1/2	20	74	9-1/2	1-1/2	93	180	3-1/2	1-1/2	90	171
145H1301-163	TO	25-13/16	1-1/4	20	0	21	1-1/4	20	180	17-1/8	1-1/4	90	19				
145H1301-165	TO	19-3/8	1-1/4	16	0	14-5/8	1-1/4	16	180								
145H1301-169	FROM	39-3/4	1	30	0	37-1/4	1	30	180	16-3/4	1	45	180	11-1/2	1	45	180
145H1302-1	TO	18-3/4	1	45	0	15-1/4	1	48	180								
145H1302-3	TO	17	1	45	0	12-7/8	1	30	225								
145H1302-5	TO	17-7/8	1	58	0	14-11/16	1	58	180								
145H1302-7	TO	18	1	48	0	15-7/8	1	48	180								
145H1302-9	TO	4-5/16	1-1/2	20	0												
145H1302 11	FROM	51-1/16	1-1/2	15	0	49-13/16	1-1/2	36	180	47-5/16	1-1/2	99	90	28-5/16	1-1/2	90	18
145H1302-13	TO	6-3/8	1-1/4	44	0	3-15/16	1-1/4	139	180								
145H1302-18	FROM	51-3/8	1-1/2	30	0	49-9/16	1-1/2	52	270	22-1/4	1-1/2	25	220	18-3/16	1-1/2	90	310
145H1302-20	FROM	14-11/16	1-1/2	88	0	6-9/16	1-1/2	90	169								
145H1302-21	TO	53-3/8	1-1/2	90	0	50-3/16	1-1/2	12	90	46-1/4	1-1/2	90	180	42-9/16	1-1/2	90	90
145H1302-23	TO	22-1/2	1-1/2	55	0	18-3/4	1-1/2	58	180								
145H1302-25	FROM	17-15/16	1-1/2	92	0	5-3/16	1-1/2	90	270								
145H1302-27	FROM	20-3/4	1-1/2	104	0	12-3/16	1-1/2	90	251	7	1-1/2	20	341				
145H1302-29	TO	14-11/16	2-1/2	87	0	5-3/16	2-1/2	55	271								
145H1302-31	FROM	8-3/16	1-1/2	20	0												
145H1302-34	TO	38-3/8	2	67	0	30-3/4	2	34	180	25-7/8	2	90	90	14-5/8	2	90	208
145H1302-35	TO	22-13/16	1-1/2	38	0	19-1/2	1-1/2	38	180								
145H1302-37	FROM	26-1/4	1-3/4	34	0	17-5/16	1-3/4	53	198	12	1-3/4	70	22	7-3/16	1-3/4	68	120
145H1302-39	TO	34-1/2	1-1/2	90	0	30-1/4	1-1/2	90	270	24	1-1/2	90	90	14-1/2	1-1/2	55	93
145H1302-41	TO	21-5/8	2	93	0	12-1/4	2	48	90								
145H1302-44	TO	21-5/8	2	93	0	12-1/4	2	48	90								
145H1302-46	FROM	15-1/4	2	40	0	9-1/4	3	40	90								
145H1302-47	FROM	10-15/16	2	40	0	3-7/16	2	40	180								
145H1302-50	FROM	4-1/2	1-1/4	75	0												
145H1302-51	TO	6-7/8	2	53	275	18-3/16	2	46	35	30-7/16	2	54	0				
145H1302-53	FROM	17-1/2	2	90	0												

B. Tube Bend Data SHEET 3 OF 13

BEND DATA																	
PART NUMBER	FLOW REL TO X END	BEND 5				BEND 6				BEND 7				BEND 8			
		DIST FROM X END	RAD	DIAL H DEG BEND	DIAL C SET	DIST FROM X END	RAD	DIAL H DEG BEND	DIAL C SET	DIST FROM X END	RAD	DIAL H DEG BEND	DIAL C SET	DIST FROM X END	RAD	DIAL H DEG BEND	DIAL C SET
145H1302-11	FROM	20-7/16	1-1/2	90	123	7-1/16	1-1/2	11	303	5-7/16	1-1/2	55	123				
145H1302-21	TO	38-1/2	1-1/2	90	90	20 -1/4	1-1/2	90	270	13-1/8	1-1/2	80	157	4-5/16	1-1/2	85	8
145H1302-34	TO	5-1/8	2	68	8												
145H1302-39	TO	7	1-1/2	90	183												

B. Tube Bend Data SHEET 4 OF 13

Bend Data																	
PART NUMBER	FLOW REL TO X END	BEND 1				BEND 2				BEND 3				BEND 4			
		DIST FROM X END	RAD	DIAL H DEG BEND	DIAL C SET	DIST FROM X END	RAD	DIAL H DEG BEND	DIAL C SET	DIST FROM X END	RAD	DIAL H DEG BEND	DIAL C SET	DIST FROM X END	RAD	DIAL H DEG BEND	DIAL C SET
145H1302-55	FROM	42-3/8	2	12	0	32-1/4	2	18	0	21-7/8	2	44	0	10-3/8	2	90	98
145H1302-57	TO	33-1/2	1-3/4	10	0	8-1/4	1-3/4	25	0	5-1/2	1-3/4	25	180				
145H1302-59	FROM	13-3/4	1-1/2	65	0	9-9/16	1-1/2	65	0								
145H1302-61	FROM	7-1/16	1-3/4	90	0												
145H1302-63	TO	30-1/2	1-1/2	23	0	24-3/8	1-1/2	19	90	15-1/8	1-1/2	62	5	10-1/8	1-1/2	27	5
145H1302-66	FROM	6-13/16	1	90	0												
145H1302-67	TO	21-7/16	1	90	0	14-1/4	1	88	270								
145H1302-69	FROM	28-1/2	1	25	0	13-7/16	1	87	180	6-1/2	1	35	90	2-11/16	1	87	350
145H1302-72	TO	6-3/16	1	45	0												
145H1302-73	TO	19-5/8	1	25	0												
145H1302-76	FROM	52-1/4	1	45	0	46-3/16	1	82	171	38	1	8	320				
145H1302-77	FROM	6	1-1/2	129	0												
145H1302-79	FROM	8	1-1/4	70	0	4-9/16	1-1/4	20	90	3-1/8	1-1/4	20	270				
145H1302-82	TO	19-3/8	1-1/4	90	0												
145H1302-83	TO	STRAIGHT															
145H1302-86	—	STRAIGHT															
145H1302-88	FROM	4-3/8	1-1/4	20	0												
145H1302-89	TO	STRAIGHT															
145H1302-93	TO	42-1/2	1-1/2	78	0	37-1/4	1-1/2	80	180	8-1/2	1-1/2	90	0				
145H1302-95	FROM	14-7/16	1-1/2	92	0	10-1/16	1-1/2	20	90								
145H1302-97	FROM	12-5/16	1-1/2	26	0	10-7/8	1-1/2	21	180	9-1/8	1-1/2	90	270	3-1/2	1-1/2	90	180
145H1302-100	TO	51-5/8	1-1/2	5	0	45-5/8	1-1/2	107	0	41-1/4	1-1/2	18	142	37-3/4	1-1/2	90	181
145H1302-103	TO	7-5/8	1	30	0	5-3/4	1	30	180								
145H1302-105	FROM	4-1/2	1	36	0	2-3/4	1	30	180								
145H1302-108	TO	17-7/16	1	90	0	4-5/16	1	90	0								
145H1302-109	FROM	STRAIGHT															
145H1302-112	FROM	9-1/16	1	39	0	4-9/16	1	75	180								
145H1302-114	TO	4-1/2	1	59	0	2-5/8	1	29	180								
145H1302-116	TO	36-3/16	1-1/2	20	0	32-5/16	1-1/2	115	180	10-5/8	1-1/2	104	185	2-11/16	1-1/2	35	90
145H1302-117	TO	81-3/8	1-1/2	30	0	79-5/8	1-1/2	30	180	62-3/8	1-1/2	91	90	51-3/8	1-1/2	90	0
145H1302-119	FROM	35-3/4	1-1/2	20	0	33-3/4	1-1/2	27	180	18-5/8	1-1/2	31	180	16-5/8	1-1/2	90	270
145H1302-123	TO	3-1/2	1	54	0												
145H1302-125	FROM	16-3/8	1	30	0	13-1/8	1	30	180								
145H1302-127	FROM	12-1/8	1	11	0	8	1-3/4	60	90								

B. Tube Bend Data SHEET 4 OF 13

BEND DATA																	
PART NUMBER	FLOW REL TO X END	BEND 5				BEND 6				BEND 7				BEND 8			
		DIST FROM X END	RAD	DIAL H DEG BEND	DIAL C SET	DIST FROM X END	RAD	DIAL H DEG BEND	DIAL C SET	DIST FROM X END	RAD	DIAL H DEG BEND	DIAL C SET	DIST FROM X END	RAD	DIAL H DEG BEND	DIAL C SET
145H1302-63	TO	8-3/8	1-1/2	27	185												
145H1302-100	TO	30	1-1/2	40	55	27-3/16	1-1/2	62	100	20-5/8	1-1/2	10	160	19-7/16	1-1/2	8	340
145H1302-117	TO	23-3/8	1-1/2	90	0	10-3/4	1-1/2	90	270	6-3/8	1-1/2	90	182				
145H1302-119	FROM	3-1/4	1-1/2	90	140												

B. Tube Bend Data SHEET 5 OF 13

Bend Data																	
PART NUMBER	FLOW REL TO X END	BEND 1				BEND 2				BEND 3				BEND 4			
		DIST FROM X END	RAD	DIAL H DEG BEND	DIAL C SET	DIST FROM X END	RAD	DIAL H DEG BEND	DIAL C SET	DIST FROM X END	RAD	DIAL H DEG BEND	DIAL C SET	DIST FROM X END	RAD	DIAL H DEG BEND	DIAL C SET
145H1401-2	TO	25-7/8	1-1/2	110	0	18-7/8	1-1/2	90	270	13-1/8	1-1/2	90	290	6-3/4	1-1/2	21	305
145H1401-4	TO	6-1/2	1-1/2	21	0												
145H1401-5	FROM	STRAIGHT															
145H1401-7	UNION	STRAIGHT															
145H1401-10	FROM	STRAIGHT															
145H1401-10	—	52	1	30	0	49-1/4	1	30	180	39-5/8	1	30	180	37	1	30	0
145H1401-11	TO	STRAIGHT															
145H1401-14	—	STRAIGHT															
145H1401-15	FROM	113-3/8	1-1/2	18	0	112-1/4	1-1/2	18	180								
145H1401-17	TO	STRAIGHT															
145H1401-19	FROM	STRAIGHT															
145H1401-21	FROM	STRAIGHT															
145H1401-23	FROM	STRAIGHT															
145H1401-26	—	77-1/8	1	18	0	75-5/8	1	18	180								
145H1401-27	FROM	STRAIGHT															
145H1401-29	—	48-1/2	1	18	0	47	1	18	180								
145H1401-31	—	STRAIGHT															
145H1401-33	—	11-3/8	1	90	0	3-3/16	1	90	270								
145H1401-35	—	26-3/4	1	90	0	7-3/8	1	20	0	3-5/16	1	90	270				
145H1401-37	—	48-7/8	1	18	0	45-3/4	1	18	180	36-1/8	1	33	270	27-1/8	1	35	270
145H1401-41	TO	54-3/4	1-1/2	90	0	45-1/8	1-1/2	40	5	42-13/16	1-1/2	40	185	40-9/16	1-1/2	40	185
145H1401-43	—	42	1	40	0	39-1/8	1	45	168	18	1	90	224	9-5/8	1	20	135
145H1401-45	—	46	1	10	0	42-1/4	1	10	180								
145H1401-48	—	27-3/8	1	30	0	22-15/16	1	28	180	9-3/8	1	90	25	2-7/16	1	21	42
145H1401-49	—	49-3/8	1	13	0	44-5/8	1	19	0	35-13/16	1	17	0	26-15/16	1	33	0
145H1401-51	—	39-1/4	1	21	0	35-1/4	1	27	185	17-1/8		46	195	14-7/16	1	44	45
145H1401-53	—	11-7/16	1	31	0	6-1/2	1	54	42								
145H1401-57	FROM	54-5/8	1-1/2	43	0	51-5/16	1-1/2	43	0	11-3/16	1-1/2	9	180				
145H1401-59	FROM	43	1-1/2	8	0	37-1/4	1-1/2	38	240	29-1/16	1-1/2	23	250	21	1-1/2	9	250
145H1401-61	—	15-1/4	1	85	0	3-1/16	1	105	90								
145H1401-63	FROM	41-13/16	1	90	0	35-1/8	1	90	0	29-3/8	1	90	204	10-5/16	1	80	244
145H1401-65	—	11	1	34	0	8-1/8	1	34	180								
145H1401-68	TO	50-7/8	1-1/2	30	0	47-1/8	1-1/2	90	270	12-1/2	1-1/2	47	270	7-5/8	1-1/2	47	90
145H1401-70	TO	96	1-1/2	10	0	43-5/8	1-1/2	90	90	8-7/8	1-1/2	43	80	3-5/8	1-1/2	43	260

B. Tube Bend Data SHEET 5 OF 13

BEND DATA																	
PART NUMBER	FLOW REL TO X END	BEND 5				BEND 6				BEND 7				BEND 8			
		DIST FROM X END	RAD	DIAL H DEG BEND	DIAL C SET	DIST FROM X END	RAD	DIAL H DEG BEND	DIAL C SET	DIST FROM X END	RAD	DIAL H DEG BEND	DIAL C SET	DIST FROM X END	RAD	DIAL H DEG BEND	DIAL C SET
145H1401-21	—	8-7/8	1	50	90	5-5/8	34	3	3-11/16	1	34	178					
145H1401-37	—	2-3/4	1	83	97												
145H1401-41	TO	23-5/8	1-1/2	30	180	16-1/8	1-1/2	38	180	5-1/8	1-1/2	12	180				
145H1401-43	—	7-1/4	1	20	315	5-5/8		88	45								
145H1401-49	—	17-1/4	1	35	56	13-1/8	1	35	235								
145H1401-59	FROM	15	1-1/2	12	250	8-1/2	1-1/2	18	163	3-7/8	1-1/2	90	70				
145H1401-63	FROM	2-15/16	1	39	165												
145H1401-68	TO	5-1/4	1-1/2	15	178	3-3/4	1-1/2	15	352								

B. Tube Bend Data SHEET 6 OF 13

Bend Data																	
PART NUMBER	FLOW REL TO X END	BEND 1				BEND 2				BEND 3				BEND 4			
		DIST FROM X END	RAD	DIAL H DEG BEND	DIAL C SET	DIST FROM X END	RAD	DIAL H DEG BEND	DIAL C SET	DIST FROM X END	RAD	DIAL H DEG BEND	DIAL C SET	DIST FROM X END	RAD	DIAL H DEG BEND	DIAL C SET
145H1401-71	FROM	57-3/4	1-1/2	90	0	46-3/4	1-1/2	90	180	14-1/16	1-1/2	50	174	9-1/4	1-1/2	61	23
145H1401-73	TO	50-1/4	1-1/2	90	0	43-1/2	1-1/2	90	180	9-1/4	1-1/2	60	152	5-3/4	1-1/2	60	332
145H1401-75	—	2-5/8	1	51	0												
145H1401-77	—	5-5/16	1	51	0	2-1/2	1	90	270								
145H1401-79	TO	25	1-1/2	12	0	21	1-1/2	21	180								
145H1402-2	TO	5-5/8	1	32	0												
145H1402-3	TO	STRAIGHT															
145H1402-5	TO	STRAIGHT															
145H1402-7	FROM	STRAIGHT															
145H1402-9	TO	STRAIGHT															
145H1402-11	TO	STRAIGHT															
145H1402-14	—	STRAIGHT															
145H1402-15	FROM UNION	STRAIGHT															
145H1402-17	TO	STRAIGHT															
145H1402-19	TO	STRAIGHT															
145H1402-23	—	STRAIGHT															
145H1402-25	FROM	15-1/4	1-1/2	30	0	12	1-1/2	30	165								
145H1402-28	FROM	64	1-1/2	17	0	61-3/4	1-1/2	90	90	24-7/8	1-1/2	90	0	14-1/2	1-1/2	45	90
145H1402-30	FROM	63-1/4	1-1/2	17	0	61-1/8	1-1/2	90	90	25-1/8	1-1/2	90	0	14-1/2	1-1/2	45	90
145H1402-31	TO	54-1/8	1-1/2	90	0	46-1/2	1-1/2	39	175	14-1/8	1-1/2	39	175	9	1-1/2	54	32
145H1402-33	FROM	49-3/4	1-1/2	90	0	41-3/4	1-1/2	90	180	7-7/8	1-1/2	66	160	4-7/8	1-1/2	66	340
145H1801-1	TO	3-3/4	1-1/2	49	270												
145H1801-3	TO	17-3/4	1-1/2	90	0	13-1/4	1-1/2	90	180	4-5/8	1-1/2	90	82				
145H1801-5	FROM	29-3/8	1-1/2	45	0	25-1/8	1-1/2	45	180	7-3/8	1-1/2	45	10	4	1-1/2	45	190
145H1801-7	FROM	21-1/2	1-1/2	90	0	15	1-1/2	90	180	2-1/8	1-1/2	18	180				
145H1601-9	—	20-1/4	1	90	0	17-1/4	1	53	95	4-7/8	1	31	275				
145H1801-15	—	24-3/8	1	108	0	20-3/4	1	25	180	7-5/16	1	41	215	3-7/8	1	40	33
145H1801-17	—	24-1/2	1	90	0	21	1	90	270	6-7/8	1	37	90				
145H1801-19	TO	34	1	42	0	28-7/8	1	62	180	24-3/16	1	66	0	3-7/8	1	7	0
145H1801-21	—	34-11/16	1	98	0	27-5/8	1	28	170	23-1/8	1	18	350	13-7/16	1	52	267
145H1801-23	TO	14-3/4	1-1/2	90	0	5-1/8	1-1/2	90	180								
145H1801-25	TO	25-3/4	1	40	0	19-3/8	1	40	180	8-3/4	1	48	4	3-1/2	1	48	4
145H1801-27	FROM	46-3/8	1	90	0	4-3/16	1	30	95								

B. Tube Bend Data SHEET 6 OF 13

BEND DATA																	
PART NUMBER	FLOW REL TO X END	BEND 5				BEND 6				BEND 7				BEND 8			
		DIST FROM X END	RAD	DIAL H DEG BEND	DIAL C SET	DIST FROM X END	RAD	DIAL H DEG BEND	DIAL C SET	DIST FROM X END	RAD	DIAL H DEG BEND	DIAL C SET	DIST FROM X END	RAD	DIAL H DEG BEND	DIAL C SET
145H1401-71	FROM	3	1-1/2	28	257												
45H1402-28	FROM	9-1/2	1-1/2	90	180												
45H1402-30	FROM	9-3/8	1-1/2	90	180												
45H1402-31	TO	4	1-1/2	29	262												

B. Tube Bend Data SHEET 7 OF 13

Bend Data																	
PART NUMBER	FLOW REL TO X END	BEND 1				BEND 2				BEND 3				BEND 4			
		DIST FROM X END	RAD	DIAL H DEG BEND	DIAL C SET	DIST FROM X END	RAD	DIAL H DEG BEND	DIAL C SET	DIST FROM X END	RAD	DIAL H DEG BEND	DIAL C SET	DIST FROM X END	RAD	DIAL H DEG BEND	DIAL C SET
145H1801-29	TO	32-3/16	1	35	0	29-3/16	1	39	90	25-3/8	1	41	275	14-11/16	1	90	270
145H1801-31	FROM	58-1/2	1	60	0	41	1	72	180	7-5/16	1	77	180				
145H1801-33	FROM	42-15/16	1	70	0	39-5/8	1	67	181	34-3/8	1	12	104	28-1/8	1	30	101
145H1801-35	FROM	28	1	45	0	21-1/2	1	55	34								
145H1801-37	TO	7-3/4	1	66	0	5-3/8	1	47	185		1	58	180				
145H1801-40	TO	33-1/4	1	60	0	27-1/2	1	90	90	23-1/4	1	90	210	20-7/8	1	44	117
145H1801-41	TO	8	1	90	0												
145H1801-44	TO	28-1/8	1	90	0	20-1/2	1	90	180	16-3/16	1	90	0	6-15/16	1	90	340
145H1801-45	TO	104	1	45	0	97-3/16	1	45	0	8-3/16	1	45	0	1-15/16	1	45	0
145H1801-47	TO	104	1	45	0	97-3/16	1	45	0	8-3/16	1	45	0	1-15/16	1	45	0
145H1801-49	FROM	8	1	90	0												
145H1801-52	TO	30-5/16	1	90	0	21-7/16	1	24	5	12-7/16	1	17	280	9-13/16	1	68	25
145H1801-54	FROM	16-1/8	1	90	0	13-1/8	1	73	270	7-15/16	1	41	270	5-1/8	1	90	180
145H1801-55	FROM	8-13/16	1	108	0	4-3/8	1	49	253								
145H1801-57	FROM	31-3/16	1	53	0	27-5/8	1	20	0	25-15/16	1	20	180	14-5/16	1	47	290
145H1801-59	FROM	15-11/16	1	30	0	12-5/16	1	31	180	10-1/4	1	90	270				
145H1801-61	TO	16-1/4	1	30	0	13-1/16	1	31	180	11-1/8	1	90	90				
145H1801-63	TO	5-3/16	1	70	0	2-3/4	1	90	90								
145H1801-65	TO	14-1/2	1	90	0	9-3/16	1-1/2	68	270	6-3/8	1-1/2	90	180				
145H1801-67	FROM	9-1/2	1	90	0	3-5/16	1	29	270								
145H1801-70	FROM	32-13/16	1	52	0	18-11/16	1	62	307	13-5/8	1	65	128	8-3/16	1	30	160
145H1801-71	FROM	12-13/16	1	8	0	7-7/8	1	90	270								
145H1801-73	TO	13-5/8	1	8	0	8-7/8	1	90	90								
145H1801-75	TO	6-1/2	1	90	0	3-3/16	1	70	90								
145H1801-77	FROM	19-7/8	1	90	0	10-3/4	1	41	50	8-7/16	1	40	228	2	1	59	265
145H1801-79	FROM	32	1	90	0												
145H1801-81	FROM	17-1/4	2-1/4	90	0	4-5/8	2-1/4	12	280								
145H1801-83	—	12-1/2	1	90	0												
145H1801-85	FROM	11-3/8	1	18	0	8-5/8	1	59	105	2-3/4	1	40	65				
145H1801-88	TO	30	1	25	0	23-11/16	1	90	90	6-5/16	1	45	0	4-13/16	1	90	270
145H1801-89	FROM	18-1/2	1	30	0	15-1/8	1	31	180	11-11/16	1	90	270				
145H1801-91	FROM	7-1/2	1	28	0	3-3/8	1	49	155								
145H1801-93	TO	25-3/16	1	20	0	22-13/16	1	19	170	7-1/2	1	22	155	5-3/16	1	56	66
145H1801-95	—	9	1	31	0	2-3/8	1	46	355								

B. Tube Bend Data SHEET 7 OF 13

BEND DATA																	
PART NUMBER	FLOW REL TO X END	BEND 5				BEND 6				BEND 7				BEND 8			
		DIST FROM X END	RAD	DIAL H DEG BEND	DIAL C SET	DIST FROM X END	RAD	DIAL H DEG BEND	DIAL C SET	DIST FROM X END	RAD	DIAL H DEG BEND	DIAL C SET	DIST FROM X END	RAD	DIAL H DEG BEND	DIAL C SET
145H1801-29	TO	6-13/16	1	90	86	3-5/8	1	16	357								
145H1801-33	FROM	7-11/16	1	62	186	8-1/4	1	71	35								
145H1801-40	TO	19	1	35	297	15-1/4	1	30	297	12-3/8	1	21	117	5-1/8	1	90	205
145H1801-57	FROM	11-3/16	1	47	110												
145H1801-70	FROM	6-7/8	1	27	340												
145H1801-93	TO	3-1/8	1	130	245												

B. Tube Bend Data SHEET 8 OF 13

Bend Data																	
PART NUMBER	FLOW REL TO X END	BEND 1				BEND 2				BEND 3				BEND 4			
		DIST FROM X END	RAD	DIAL H DEG BEND	DIAL C SET	DIST FROM X END	RAD	DIAL H DEG BEND	DIAL C SET	DIST FROM X END	RAD	DIAL H DEG BEND	DIAL C SET	DIST FROM X END	RAD	DIAL H DEG BEND	DIAL C SET
145H1801-97	FROM	26-1/16	1	120	0	22-9/16	1	32	180	16-1/4	1	62	90	11-5/16	1	63	270
145H1801-99	TO	15-5/8	2	92	0												
145H1801-101	—	35-1/8	1	15	0	29-7/8	1	15	180								
145H1801-103	TO	7-7/16	1	180	0	2	1	15	115								
145H1801-106	—	44-5/16	1	90	0	40-1/2	1	90	180	23-13/16	1	80	188	20-3/8	1	81	3
145H1801-107	FROM	32-1/8	1-1/2	50	0	26-5/8	1-1/2	50	180	24-1/8	1-1/2	36	90	18-3/4	1-1/2	90	180
145H1801-111	FROM	7-1/8	1	46	0	3-3/4	1	55	5								
145H1801-113	FROM	7-3/16	1	75	0	3-1/2	1	74	84								
145H1801-131	FROM	35	1-1/2	30	0	23-1/4	1-1/2	93	270	9-3/4	1-1/2	90	65	4-3/8	1-1/2	17	155
145H1801-135	FROM	24-1/2	1-1/2	90	0	17-5/8	1-1/2	90	0	8-3/4	1-1/2	90	246	3-5/16	1-1/2	86	79
145H1801-141	FROM	41-3/8	1-1/4	90	0	20-3/16	1-1/4	47	240	3-1/4	1-1/4	90	180				
145H1801-143	TO	37	1-1/2	50	0	32-7/16	1-1/2	50	180	20-5/16	1-1/2	40	177	13-7/16	1-1/2	38	10
145H1801-145	FROM	32-5/16	1	112	0	28-11/16	1	19	180	23-13/16	1	90	180	14-1/2	1	80	270
145H1801-150	TO	29-3/16	1	104	0	24-15/16	1	27	247	14-1/8	1	20	270	9-1/4	1	80	270
145H1801-152	FROM	15-1/2	2-1/4	97	0												
145H1801-153	FROM	55-1/4	1	10	0	53-7/8	1	90	90	24-11/16	1	90	255	17-7/8	1	25	165
145H1801-156	TO	23-11/16	1	94	0	14-1/2	1	15	287	8-1/2	1	20	244				
145H1801-157	FROM	22-1/8	1	90	0	13-1/8	1	47	38	9-7/8	1	90	262	4	1	88	83
145H1801-160	TO	9-5/8	1-3/4	46	0	4-5/16	1-3/4	45	23								
145H1801-161	TO	32-7/8	2	50	0	27-1/8	2	50	180	13-3/4	2	40	152	10-1/8	2	40	333
145H1801-163	FROM	48-7/8	2	92	0	44-7/8	2	45	94	32-3/16	2	20	96	27-1/16	2	90	178
145H1801-165	TO	15-13/16	1	144	0	5	2	66	228								
145H1801-167	TO	15-1/4	1	5	0	9-1/16	1	90	90								
145H1801-169	TO	33-5/8	1	90	0	29-15/16	1	40	270	19	1	90	180	2-7/8	1	96	227
145H1801-171	TO	19-1/2	1-1/2	90	0												
145H1801-173	FROM	42-13/16	1-3/4	72	0	37-9/16	1-3/4	47	200	25-7/16	1-3/4	30	335	17-5/16	1-3/4	13	349
145H1801-175	TO	12-3/4	1-1/2	109	0	3-5/8	1-1/2	40	165								
145H1801-177	FROM	41-1/16	2	45	0	35-15/16	2	45	180	24-1/8	2	89	292	8-5/8	2	48	207
145H1801-180	FROM	9-3/16	1-3/4	45	0	5	1-3/4	45	0								
145H1801-181	TO	104	1	45	0	97-3/16	1	45	0	8-13/16	1	45	0	1-15/16	1	45	0
145H1801-182	TO	17-3/8	1	68	0	10	1	75	270	3	1	90	174				
145H1801-187	TO	104	1	45	0	97-3/16	1	45	0	8-13/16	1	45	0	1-15/16	1	45	0
145H1801-191	TO	18-3/16	1	30	0	14-7/8	1	31	180	11-1/2	1	90	90				
145H1801-196	FROM	32-7/16	1	44	0	15-7/16	1	90	40	2-5/8	1	8	310				

B. Tube Bend Data SHEET 8 OF 13

BEND DATA																	
PART NUMBER	FLOW REL TO X END	BEND 5				BEND 6				BEND 7				BEND 8			
		DIST FROM X END	RAD	DIAL H DEG BEND	DIAL C SET	DIST FROM X END	RAD	DIAL H DEG BEND	DIAL C SET	DIST FROM X END	RAD	DIAL H DEG BEND	DIAL C SET	DIST FROM X END	RAD	DIAL H DEG BEND	DIAL C SET
145H1801-97	FROM	2-3/8	1	90	100												
145H1801-106	—	15-3/16	1	19	107	8-9/16	1	15	277								
145H1801-143	TO	7-1/4	1-1/2	22	128	5-5/16	1-1/2	90	30								
145H1801-145	FROM	11-5/16	1	90	0	5-5/16	1	90	193								
145K1801-153	FROM	9-3/16	1	20	165	3-5/8	1	90	255								
145H1801-163	FROM	4-3/4	2	90	38												
145H1801-173	FROM	8-1/2	1-3/4	90	68												

B. Tube Bend Data SHEET 9 OF 13

Bend Data																	
PART NUMBER	FLOW REL TO X END	BEND 1				BEND 2				BEND 3				BEND 4			
		DIST FROM X END	RAD	DIAL H DEG BEND	DIAL C SET	DIST FROM X END	RAD	DIAL H DEG BEND	DIAL C SET	DIST FROM X END	RAD	DIAL H DEG BEND	DIAL C SET	DIST FROM X END	RAD	DIAL H DEG BEND	DIAL C SET
145H1801-197	FROM	44-3/8	1-1/2	28	0	31-3/8	1-1/2	23	5	23-5/8	1-1/2	91	96	10-5/8	1-1/2	88	300
145H1801-199	TO	66-3/4	1-1/2	89	0	53-5/8	1-1/2	6	255	32-1/8	1-1/2	87	160	14-1/8	1-1/2	20	70
145H1801-201	TO	8-1/8	1-1/2	108	0	3	1-1/2	24	90								
145H1801-206	FROM	34-1/4	1	14	0	33-1/8	1	90	270	5	1	67	270	2-1/4	1	66	270
145H1801-208	FROM	36-3/4	1	45	0	35	1	90	270	5-3/16	1	66	199	2-7/16	1	66	122
145H1801-211	TO	24-3/8	1	65	0	17-3/4	1	65	180	5-7/8	1	75	305	2-9/16	1	75	125
145H1801-213	TO	30-1/8	1	45	0	28-7/8	1	45	180	22-9/16	1	75	305	5-3/16	1	75	298
145H1801-215	TO	14-1/8	1	50	0	2-3/4	1	65	10								
145H1801-217	TO	14-1/8	1	50	0	2-3/4	1	65	10								
145H1801-219	TO	14-1/8	1	50	0	2-3/4	1	65	10								
145H1801-221	TO	2-7/16	1	130	0												
145H1801-223	—	17-13/16	1	90	0	12-7/16	1	90	270	3-1/8	1	53	90				
145H1801-225	—	6-3/8	1	35	0	2-1/8	1	80	10								
145H1801-227	TO	18-1/2	1	75	0	1-5/8	1	45	295								
145H1801-229	FROM	18-3/4	1	60	0	2-5/8	1	80	305								
145H1801-231	—	13-1/4	1	45	0	10-1/16	1	40	0	3-5/16	1	68	270				
145H1801-233	TO	9-7/8	1	130	0	2-7/16	1	78	109								
145H1801-235	TO	17-1/2	1-1/2	90	0	6-5/8	1-1/2	90	180								
145H1801-237	FROM	13-1/4	1-1/2	90	0	9-7/8	1-1/2	132	270	4-3/8	1-1/2	90	180				
145H1801-239	TO	15-9/16	2-1/2	88	0	6-5/16	2-1/2	29	90								
145H1801-241	FROM	26-3/8	2-1/2	115	0	13-3/8	2-1/2	90	242	2-3/4	2-1/2	9	332				
145H1801-243	FROM	38-1/4	2-1/4	115	0	31-7/8	2-1/4	90	90	7-5/8	2-1/4	92	155				
145H1801-245	TO	30-3/4	1-3/4	8	0	26-11/16	1-3/4	90	90	15-3/4	1-3/4	40	0	9-1/2	1-3/4	48	266
145H1801-247	FROM	14	1	45	0	12	1	43	180	9-3/4	1	50	62	2-3/8	1	38	52
145H1801-250	TO	28-5/8	1	90	0	25-7/8	1	59	270	9-3/8	1	90	180	3	1	19	270
145H1801-251	TO	15-13/16	1	5	0	9-5/16	1	90	270								
145H1801-253	TO	104	1	45	0	97-3/16	1	45	0	8-13/16	1	45	0	1-15/16	1	45	0
145H1801-256	TO	17-5/8	1-1/2	90	0	9-1/8	1-1/2	90	180								
145H1801-257	FROM	62-1/2	1-1/2	90	0	54-15/16	1-1/2	90	292	41-7/8	1-1/2	16	106	21-1/8	1-1/2	90	19
145H1801-261	FROM	27-3/16	1-1/2	90	0	3-3/8	1-1/2	90	0								
145H1801-263	FROM	35-7/8	1-1/2	15	0	28-3/8	1-1/2	92	115	15-1/2	1-1/2	45	198	10-5/8	1-1/2	45	114
145H1801-267	FROM	7-1/2	1	41	0	2-5/16	1	35	160								
145H1801-269	TO	10	1-1/4	102	0	5	1-1/4	108	85								

B. Tube Bend Data SHEET 9 OF 13

BEND DATA																	
PART NUMBER	FLOW REL TO X END	BEND 5				BEND 6				BEND 7				BEND 8			
		DIST FROM X END	RAD	DIAL H DEG BEND	DIAL C SET	DIST FROM X END	RAD	DIAL H DEG BEND	DIAL C SET	DIST FROM X END	RAD	DIAL H DEG BEND	DIAL C SET	DIST FROM X END	RAD	DIAL H DEG BEND	DIAL C SET
145H1801-199	TO	6	1-1/2	15	160	3-1/2	1-1/2	12	340								
145H1801-213	TO	2-7/8	1	74	118												
145H1801-245	TO	3-1/4	1-3/4	62	20												
145H1801-257	FROM	2-3/8	1-1/2	40	109												
145H1801-263	FROM	5	1-1/2	35	193	2-13/16	1-1/2	65	10								

B. Tube Bend Data SHEET 10 OF 13

Bend Data																	
PART NUMBER	FLOW REL TO X END	BEND 1				BEND 2				BEND 3				BEND 4			
		DIST FROM X END	RAD	DIAL H DEG BEND	DIAL C SET	DIST FROM X END	RAD	DIAL H DEG BEND	DIAL C SET	DIST FROM X END	RAD	DIAL H DEG BEND	DIAL C SET	DIST FROM X END	RAD	DIAL H DEG BEND	DIAL C SET
145H1801-271	FROM	47-15/16	1-1/2	90	0	36-1/4	1-1/2	90	270								
145H1802-1	FROM	14-7/8	1-1/2	90	0	6-1/4	1-1/2	45	270								
145H1802-3	FROM	15-5/8	1-1/2	90	0	10-1/4	1-1/2	90	180	3-1/2	1-1/2	90	60				
145H1802-5	TO	29-3/4	1-1/2	90	0	25	1-1/2	90	180								
145H1802-7	TO	14-1/2	1-1/2	90	0	9-5/8	1-1/2	90	180								
145H1802-9	TO	STRAIGHT															
145H1802-11	TO	36	1-1/2	60	0	32-7/8	1-1/2	82	255	3-15/16	1-1/2	31	145				
145H1802-14	TO	17-3/8	1	20	0	15-1/2	1	38	211	11-7/8	1	90	150	6-3/4	1	40	55
145H1802-15	FROM	32-5/8	2	28	0	24-5/16	2	25	180	14-1/8	2	25	180	2-11/16	2	23	0
145H1802-17	TO	14	1-1/2	32	0	11-5/8	1-1/2	90	270								
145H1802-20	TO	23	1-1/2	24	0	17-11/16	1-1/2	24	0	8-3/16	1-1/2	24	0	1-13/16	1-1/2	31	90
145H1802-22	FROM	41-9/16	1-1/2	20	0	20-15/16	1-1/2	74	310								
145H1802-24	TO	33-1/8	1-1/2	35	0	29-13/16	1-1/2	35	180	14-5/8	1-1/2	10	130	2-3/4	1-1/2	15	154
145H1802-25	TO	14-15/16	1-1/4	80	0	9-7/8	1-1/4	75	114	2-1/2	1-1/4	30	39				
145H1802-27	FROM	7-3/4	1-1/2	90	0	3-1/2	1-1/2	17	90								
145H1802-29	TO	32-3/16	1-1/2	24	0	28-9/16	1-1/2	90	250	22-9/16	1-1/2	90	75	12-7/8	1-1/2	40	80
145H1802-33	FROM	19-7/8	1-1/2	50	0	11-3/16	1-1/2	10	9	6-3/4	1-1/2	61	190				
145H1802-35	TO	13-5/8	2	82	0	6-5/8	2	71	322								
145H1802-38	FROM	21-1/4	1-3/4	35	0	17-1/2	1-3/4	90	90								
145H1802-40	FROM	26-3/8	1	170	0	19-1/8	1	110	115	14-5/16	1	90	209	3	1	90	115
145H1802-41	TO	27-5/16	2	175	0	17	2	54	85	9-3/4	2	28	176	5-1/8	2	92	194
145H1802-43	TO	34-1/4	2	90	0	27-7/8	2	90	180	7	2	90	355				
145H1802-45	FROM	23-5/8	2	42	0	19-1/8	2	40	178	15-1/8	2	30	153	11-3/8	2	30	330
145H1802-47	TO	52-1/8	2	90	0	45-5/8	2	90	181	24-7/8	2	90	8				
145H1802-49	TO	27-9/16	2	177	0	17-1/4	2	54	275	10	2	25	184	5-3/8	2	92	164
145H1802-51	FROM	14-1/8	1-1/2	90	0	11	1-1/2	135	180	5	1-1/2	45	0				
145H1802-53	FROM	33	1-3/4	30	0	27-1/4	1-3/4	45	180	18-1/2	1-3/4	25	180	6-3/4	1-3/4	90	9
145H1802-55	TO	STRAIGHT															
145H1802-57	TO	41-1/2	2	45	0	36-9/16	2	45	223	23-7/8	2	31	296	7-1/4	2	90	28
145H1802-60	TO	50-3/16	1-1/2	27	0	46-9/16	1-1/2	50	45	32-7/8	1-1/2	20	43	16-5/8	1-1/2	45	116
145H1802-62	TO	STRAIGHT															
145H1802-67	FROM	41-7/8	1-1/2	33	0	33-11/16	1-1/2	17	0	25-11/16	1-1/2	17	0	2-13/16	1-1/2	70	177
145H1802-70	TO	36-3/8	1-1/2	92	0	22-1/8	1-1/2	89	150	11-3/16	1-1/2	68	236	2-7/8	1-1/2	45	272
145H1802-71	TO	16-7/8	2	38	0	12-1/4	2	47	356	7-7/8	2	31	72	4	2	23	266

B. Tube Bend Data SHEET 10 OF 13

BEND DATA																	
PART NUMBER	FLOW REL TO X END	BEND 5				BEND 6				BEND 7				BEND 8			
		DIST FROM X END	RAD	DIAL H DEG BEND	DIAL C SET	DIST FROM X END	RAD	DIAL H DEG BEND	DIAL C SET	DIST FROM X END	RAD	DIAL H DEG BEND	DIAL C SET	DIST FROM X END	RAD	DIAL H DEG BEND	DIAL C SET
145H1802-14	TO	3-5/16	1	40	236												
145H1802-29	TO	8-1/16	1-1/2	40	263	4-3/8	1-1/2	30	0								
145H1802-60	TO	13-1/8	1-1/2	45	291	10-3/4	1-1/2	72	289	3-3/4	1-1/2	20	282				

B. Tube Bend Data SHEET 11 OF 13

Bend Data																	
PART NUMBER	FLOW REL TO X END	BEND 1				BEND 2				BEND 3				BEND 4			
		DIST FROM X END	RAD	DIAL H DEG BEND	DIAL C SET	DIST FROM X END	RAD	DIAL H DEG BEND	DIAL C SET	DIST FROM X END	RAD	DIAL H DEG BEND	DIAL C SET	DIST FROM X END	RAD	DIAL H DEG BEND	DIAL C SET
145H1802-73	TO	33-1/16	1-1/2	42	0	27-7/8	1-1/2	42	180	25-1/2	1-1/2	43	270	19	1-1/2	90	180
145H1802-75	FROM	12-13/16	1-1/2	90	0	8-3/16	1-1/2	90	0								
145H1802-77	FROM	6-9/16	1-1/2	90	0												
145H1802-79	TO	11-5/8	2	90	0	5-3/8	2	90	273								
145H1802-81	FROM	22-5/16	2	90	0	11-15/16	2	90	273								
145H1802-83	TO	18	3-1/4	90	0	7-3/4	3-1/4	60	255								
145H1802-86	TO	31-1/4	3-1/4	95	0	24-1/8	3-1/4	88	67	12-7/8	3-1/4	37	7	8-3/4	3-1/4	120	155
145H1802-87	FROM	18-11/16	1-1/2	42	0	16-9/16	1-1/2	42	180	5-11/16	1-1/2	45	127	3-3/16	1-1/2	45	310
145H1802-89	FROM	45	1-1/2	90	0	39-3/4	1-1/2	90	140	32	1-1/2	50	50	18-1/2	1-1/2	90	320
145H1802-91	TO	28-7/8	2-1/4	130	0	18	2-1/4	32	277	10	2-1/4	90	199				
145H1802-93	TO	3-5/8	1	35	0												
145H1802-97	FROM	7-3/4	1-1/2	22	0	6-1/4	1-1/2	22	180								
141H1802-99	TO	60	1-1/2	90	0	54	1-1/2	90	193	41-1/16		17	101	18-15/16	1-1/2	90	2
145H1802-103	TO	27-3/16	1-1/2	90	0	3-3/8	1-1/2	90	0								
145H1802-105	TO	28-15/16	1-1/2	86	0	18-7/8	1-1/2	55	267	5	1-1/2	90	210				
145H1802-107	TO	48-15/16	1-1/2	45	0	45-7/8	1-1/2	45	180	36-1/4	1-1/2	90	152				
145H1802-109	FROM	9-3/4	1-1/4	90	0	4-7/16	1-1/4	109	87								
145H1802-111	FROM	21-1/4	1	43	0	18-13/16	1	44	180	2-15/16	1	61	265				
145H1802-117	FROM	5-9/16	1	29	0	3-3/16	1	67	170								
145H1802-119	FROM	12-1/4	1	35	0	3-7/8	1	90	270								
145H1802-122	TO	2-1/4	1	48	0												
145H1802-123	FROM	62	1	50	0	55-15/16	1	20	330	40-1/16	1	20	355	34-1/8	1	20	175
145H1802-127	TO	21-5/8	1	103	0	17-7/8	1	90	170	13-1/2	1	90	30	3-1/4	1	90	210
145H1802-129	TO	28-3/16	1	128	0	22-15/16	1	41	180	13-7/8	1	90	273	8-3/8	1	90	180
145H1802-133	TO	21-7/8	1	70	0	17-1/8	1	90	90	11-3/16	1	90	195				
145H1802-137	TO	34-1/16	1	90	0	31-3/8	1	90	180	21-5/16	1	90	165	17-1/4	1	30	310
145H1802-139	FROM	33-1/8	1	90	0	23-5/16	1	92	93	10-13/16	1	45	246	8-15/16	1	43	68
145H1802-141	TO	61-1/8	1	15	0	54-7/8	1	90	270	41-1/4	1	90	113	34-1/8	1	22	200
145H1802-143	FROM	29-3/8	1	63	0	19-1/2	1	28	46	10-1/2	1	24	224	6-3/8	1	67	32
145H1802-147	FROM	29-3/8	1	90	0	18-1/16	1	90	180	6-1/8	1	90	40				
145H1802-149	TO	26-3/8	1	25	0	20-15/16	1	90	90	16-3/16	1	90	180	12-3/4	1	90	115
145H1802-151	FROM	15-3/8	1	90	0	11-1/2	1	90	180								
145H1802-153	TO	37-3/4	1	90	0	34-1/8	1	13	260	29-13/16	1	67	126	24-3/16	1	63	305
145H1802-164	FROM	36-13/16	1	61	0	33-15/16	1	66	180	10-3/8	1	90	145	4	1	90	324

B. Tube Bend Data SHEET 11 OF 13

BEND DATA																	
PART NUMBER	FLOW REL TO X END	BEND 5				BEND 6				BEND 7				BEND 8			
		DIST FROM X END	RAD	DIAL H DEG BEND	DIAL C SET	DIST FROM X END	RAD	DIAL H DEG BEND	DIAL C SET	DIST FROM X END	RAD	DIAL H DEG BEND	DIAL C SET	DIST FROM X END	RAD	DIAL H DEG BEND	DIAL C SET
145H1802-89	FROM	2-5/8	1-1/2	50	30												
145H1802-123	FROM	32-9/16	1	20	355	26-1/2	1	90	80	11-3/8	1	50	265	7-5/16	1	50	85
145H1802-129	TO	5-7/8	1	90	90												
145H1802-137	TO	15	1	25	195												
145H1502-141	TO	32-1/4	1	26	20	27-1/2	1	22	211	6-1/2	1	56	205				
145H1808-153	TO	6-1/8	1	56	218	2-11/16	1	60	35								

B. Tube Bend Data SHEET 12 OF 13

Bend Data																	
PART NUMBER	FLOW REL TO X END	BEND 1				BEND 2				BEND 3				BEND 4			
		DIST FROM X END	RAD	DIAL H DEG BEND	DIAL C SET	DIST FROM X END	RAD	DIAL H DEG BEND	DIAL C SET	DIST FROM X END	RAD	DIAL H DEG BEND	DIAL C SET	DIST FROM X END	RAD	DIAL H DEG BEND	DIAL C SET
145H1802-165	FROM	30-1/4	1	40	0	29-1/8	1	40	180	23-3/4	1	60	180	17-13/16	1	60	0
145H1802-167	TO	18-1/8	1	45	0	16-1/8	1	45	180								
145H1802-169	TO	17-15/16	1	45	0	15-15/16	1	45	180								
145H1802-171	TO	18	1	45	0	16	1	45	180								
145H1802-173	TO	17-3/4	1	45	0	15-3/4	1	45	180								
145H1802-175	TO	17-3/4	3-1/4	90	270	11-3/4	3-1/4	90	270								
145H1802-177	TO	26-1/2	3-1/4	50	0	17-1/2	3-1/4	50	180								
145H1802-179	FROM	14-1/2	1-1/2	97	0	6-5/8	1-1/2	22	230								
145H1802-181	FROM	8-1/4	3-1/4	32	0												
145H1802-183	TO	26-3/8	1-1/2	38	0	12-1/2	1-1/2	90	5	3-1/2	1-1/2	90	185				
145H1802-186	FROM	46-7/8	1-1/2	58	0	32-7/8	1-1/2	50	334	29-5/8	1-1/2	50	143	11-5/8	1-1/2	90	275
145H1802-189	FROM	23-1/2	1-1/2	82	0	14	1-1/2	90	90								
145H1802-191	TO	17-1/2	2	90	0	6-5/16	2	90	180								
145H1802-193	TO	20-3/16	1	125	0	15-15/16	1	30	180	11-1/8	1	62	90	2-15/16	1	10	90
145H1802-197	FROM	5-1/4	2	90	0												
145H1802-200	TO	35-1/8	1-3/4	25	0	33-3/8	1-3/4	25	180	29	1-3/4	95	0	14-1/8	1-3/4	88	110
145H1803-1	TO	12-7/16	1-3/4	112	0	7-13/16	1-3/4	155	293								
145H1803-6	FROM	19-11/16	1	85	0	17-1/16	1	85	0	8-9/16	1	55	140	4-11/16	1	58	233
145H1803-8	TO	19-15/16	1	30	0	6-5/8	1	80	200								
145H1803-11	FROM	43-3/4	1-3/4	40	0	37	1-3/4	80	332	32-5/16	1-3/4	80	38	17-7/16	1-3/4	90	52
145H1803-14	FROM	16-5/8	1-1/2	85	0	3-9/16	1-1/2	92	90								
145H1803-17	FROM	28-15/16	1-3/4	73	0	17-13/16	1-3/4	73	216	11-11/16	1-3/4	76	45	4-7/8	1-3/4	90	320
145H1803-23	FROM	11-3/8	1-3/4	45	0	5-11/16	1-3/4	40	90	3-1/8	1-3/4	40	270				
145H1803-25	TO	68-3/8	1-1/2	21	0	60-3/4	1-1/2	23	180	50-15/16	1-1/2	74	81	13-11/16	1-1/2	35	240
145H1803-27	FROM	66-5/8	1-1/2	25	0	60-3/4	1-1/2	29	180	49-3/4	1-1/2	73	270	12-3/8	1-1/2	36	114
145H1804-1	FROM	8-1/8	1-3/4	90	0	3-3/4	1-3/4	38	270								
145H1804-3	TO	16-5/8	2-1/2	88	0												
145H1804-5	TO	21-3/8	1-3/4	90	0	16-13/16	1-3/4	47	90	8	1-3/4	57	90	4-1/8	1-3/4	90	0
145H1804-7	TO	27-3/8	1-3/4	75	0	23	1-3/4	25	270	11-15/16	1-3/4	90	76	5-1/16	1-3/4	90	256
145H1804-10	TO	59-11/16	2-1/2	45	0	50-7/16	2-1/2	90	33	38	2-1/2	48	269	31-7/16	2-1/2	11	7
145H1804-12	TO	9-1/8	2-1/2	55	0	5	2-1/2	55	182								
145H1804-19	TO	16-3/4	2-1/2	49	0		10-7/8	2-1/2	46	172	5	2-1/2	49	299			
145H1804-21	TO	42-11/16	3	15	0	35-3/4	3	41	264	14-3/4	3	90	323				
145H1804-24	TO	27-13/16	2	52	0	21-15/16	2	93	268	11	2	92	1				

B. Tube Bend Data SHEET 12 OF 13

BEND DATA																	
PART NUMBER	FLOW REL TO X END	BEND 5				BEND 6				BEND 7				BEND 8			
		DIST FROM X END	RAD	DIAL H DEG BEND	DIAL C SET	DIST FROM X END	RAD	DIAL H DEG BEND	DIAL C SET	DIST FROM X END	RAD	DIAL H DEG BEND	DIAL C SET	DIST FROM X END	RAD	DIAL H DEG BEND	DIAL C SET
145H1802-165	FROM	5-7/8	1	65	118	2-7/16	1	63	298								
145H1802-200	TO	9-1/8	1-3/4	15	20												
145H1803-6	FROM	2-3/4	1	58	51												
145H1803-25	TO	6-7/8	1-1/2	52	65												
145H1803-27	FROM	5-13/16	1-1/2	51	281												
145H1804-10	TO	23-7/8	2-1/2	40	50	14-1/2	2-1/2	38	102	5-1/6	2-1/2	38	59				

B. Tube Bend Data SHEET 13 OF 13

Bend Data																	
PART NUMBER	FLOW REL TO X END	BEND 1				BEND 2				BEND 3				BEND 4			
		DIST FROM X END	RAD	DIAL H DEG BEND	DIAL C SET	DIST FROM X END	RAD	DIAL H DEG BEND	DIAL C SET	DIST FROM X END	RAD	DIAL H DEG BEND	DIAL C SET	DIST FROM X END	RAD	DIAL H DEG BEND	DIAL C SET
145H1804-25	TO	2-3/8	1-1/2	45	0												
145H1804-27	TO	58-7/8	1-1/2	20	180	49-9/16	1-1/2	75	83	13-3/16	1-1/2	35	235	6-7/16	1-1/2	51	283
145H1804-29	TO	63-7/8	1-1/2	18	0												
145H1804-31	TO	16-3/4	1	42	0	13-3/4	1	42	190	5-3/4	1	85	247	3	1	38	145
145H1804-33	TO	STRAIGHT															
145H1804-35	TO	5-1/2	1-1/4	90	270	13-1/8	1-1/4	100	0	8-3/4	1-1/4	88	85				
145H1402-21	FROM	51-3/8	1-1/2	20	90	45	1-1/2	40	0	42-3/4	1-1/2	40	180	40-1/8	1-1/2	40	180
-21 BEND 9	FROM	2-7/8	1-1/2	45	323												
145H1801-13	FROM	60-5/8	1	90	0	56-1/2	1	90	180	39-15/16	1	12	190	38-1/4	1	8	10
-13 BEND 9	FROM	3-3/16	1	34	188												
145H1802-125	FROM	41-7/8	1	90	0	37-7/16	1	90	270	32-1/4	1	90	0	21-3/8	1	44	270
-125 BEND 9	FROM	6-1/16	1	90	0												
145H1802-136	FROM	39-1/2	1	70	0	33-13/16	1	20	90	31-3/8	1	26	220	25-1/4	1	17	140
-136 BEND 9	FROM	4-1/16	1	12	130												
145H1803-15	TO	67-5/8	1	71	0	63-5/8	1	96	90	55-1/4	1	86	154	43-5/8	1	44	58
15 BEND 9	TO	3-1/8	1	6	251												
145P0171-1	TO	7-3/4	2	90	90	9-9/16	2	10	0								
145P0171-2	TO	7-3/4	2	90	270	9-9/16	2	10	0								

B. Tube Bend Data SHEET 13 OF 13

BEND DATA																	
PART NUMBER	FLOW REL TO X END	BEND 5				BEND 6				BEND 7				BEND 8			
		DIST FROM X END	RAD	DIAL H DEG BEND	DIAL C SET	DIST FROM X END	RAD	DIAL H DEG BEND	DIAL C SET	DIST FROM X END	RAD	DIAL H DEG BEND	DIAL C SET	DIST FROM X END	RAD	DIAL H DEG BEND	DIAL C SET
145H1402-21	FROM	37-3/4	1-1/2	35	0	23-5/16	1-1/2	30	180	15-7/8	1-1/2	38	180	4-5/8	1-1/2	12	180
145H1801-13	FROM	34-7/8	1	90	110	22-5/16	1	90	276	11	1	41	262	6-15/16	1	41	88
145H1802-125	FROM	19-9/16	1	35	90	16-1/16	1	30	90	13-5/16	1	21	270	8-1/16	1	33	270
145H1802-136	FROM	17-3/16	1	24	45	15-1/4	1	24	280	12-5/8	1	90	70	7-1/4	1	90	220
145H1803-15	TO	32-1/8	1	42	60	24-1/4	1	88	169	19-15/16	1	90	354	10-1/2	1	90	161

C. TUBE ASSEMBLY DATA (SHEET 1 OF 13)

PART NUMBER	END X FITTING		END Y FITTING		FLOW REL TO X END	NOMEN-CLATURE	NOTES
	SLEEVE	NUT	SLEEVE	NUT			
114E4048-125	MS21922-R6	MD21921-6	MS21922-R6	MS21921-6			
114E4028151			BACS13AP8	MS21921-8	—	TUBE ASSY	4
114PA302-1	—	NAS593-4	—	—	TO	TUBE ASSY	2
145H1301-1	D10007-04	D10006-04			—	TUBE ASSY	2
145H1301-3	D10007-04	D10006-04			—	TUBE ASSY	2
145H1301-7			D10007-04	D10006-04	—	TUBE ASSY	2
145H1301-9			D10007-04	D10006-04	—	TUBE ASSY	2
145H1301-11	D10007-04	D10007-04			—	TUBE ASSY	2
145H1301-13			D10007-04	D10006-04	—	TUBE ASSY	2
145H1301-15	D10007-04	D10006-04			—	TUBE ASSY	2
145H1301-17			D10019-04	—	—	TUBE ASSY	2
145H1301-21	D10019-04	—			FROM	TUBE ASSY	2
145H1301-23	D10036-08	—			TO	TUBE ASSY	2
145H1301-25			D10019-04	—	TO	TUBE ASSY	2
145H1301-27	D10019-04	—			—	TUBE ASSY	2
145H1301-30					FROM	TUBE	3
145H1301-31			D10019-04	—	—	TUBE ASSY	2
145H1301-33	D10021A-04	—			TO	TUBE ASSY	2
145H1301-35	D10007-08	D10006-08			FROM	TUBE ASSY	2
145H1301-38					FROM	TUBE	3
145H1301-39	D10007-08	D10006-08			—	TUBE ASSY	2
145H1341-42					—	TUBE	3
145H1301-45	D10019-04	—			—	TUBE ASSY	2
145H1301-47	D10019-04	—			TO	TUBE ASSY	2
145H1301-52					TO	TUBE ASSY	2
145H1301-53	D10019-04	—			—	TUBE ASSY	2
145H1301-55			D10019-04	—	—	TUBE ASSY	2
145H1301-59			D10019-04	—	FROM	TUBE ASSY	2
145H1301-61			D10007-06	D10006-06	TO	TUBE ASSY	2
145H1301-64					FROM	TUBE	3
145H1301-65	D10019-06	—			TO	TUBE ASSY	2
145H1301-68					FROM	TUBE	3
145H1301-74					TO	TUBE	3

C. TUBE ASSEMBLY DATA (SHEET 2 OF 13)

PART NUMBER	END X FITTING		END Y FITTING		FLOW REL TO X END	NOMEN-CLATURE	NOTES
	SLEEVE	NUT	SLEEVE	NUT			
145H1301-75			D10041-0604	—	FROM	TUBE ASSY	2
145H1301-78					TO	TUBE	3
145H1301-80					TO	TUBE	3
145H1301-81			D10007-04	D10006-04	TO	TUBE ASSY	2
145H1301-83			D10007-04	D10006-04	TO	TUBE ASSY	2
145H1301-86					FROM	TUBE	3
145H1301-88					FROM	TUBE	3
145H1301-89	D10019-10	—			FROM	TUBE ASSY	2
145H1301-91	D10019-06	—			TO	TUBE ASSY	2
145H1301-93	D10019-06	D10006-06			TO	TUBE ASSY	2
145H1301-95			D10019-04	—	—	TUBE ASSY	2
145H1301-97			D10007-06	D10006-06	FROM	TUBE ASSY	2
145H1301-99	D10036-04	—			—	TUBE ASSY	2
145H1301-101			D10036-04	—	—	TUBE ASSY	2
145H1301-103			D10007-04	D10006-04	—	TUBE ASSY	2
145H1301-105			D10007-06	D10006-05	FROM	TUBE ASSY	2
145H1301-115			D100019-06	—	FROM	TUBE ASSY	2
145H1301-117	D10007-08	D10006-08			TO	TUBE ASSY	2
145H1301-119			D10036-06	—	FROM	TUBE ASSY	2
145H1301-121			D10036-06	—	TO	TUBE ASSY	2
145H1301-123	D10019-06	—			TO	TUBE ASSY	2
145H1301-125	D10007-06	D10006-06			TO	TUBE ASSY	2
145H1301-127	D10007-08	D10006-08			FROM	TUBE ASSY	2
145H1301-129			D10036-08	—	TO	TUBE ASSY	2
145H1301-131			D10019-08	—	TO	TUBE ASSY	2
145H1301-133			D10007-08	D10006-08	FROM	TUBE ASSY	2
145H1301-136					TO	TUBE	3
145H1301-137	D10007-04	D10006-04			FROM	TUBE ASSY	2
145H1301-139			D10019-10	—	TO	TUBE ASSY	2
145H1301-141			D10036-06	—	FROM	TUBE ASSY	2
145H1301-143	D10036-04	—			—	TUBE ASSY	2
145H1301-146					—	TUBE	3
145H1301-151	D10007-04	D10006-04			FROM	TUBE ASSY	2

C. TUBE ASSEMBLY DATA (SHEET 3 OF 13)

PART NUMBER	END X FITTING		END Y FITTING		FLOW REL TO X END	NOMEN-CLATURE	NOTES
	SLEEVE	NUT	SLEEVE	NUT			
145H1301-155	D10019-06	—			FROM	TUBE ASSY	2
145H1301-158					FROM	TUBE	3
145H1301-160					TO	TUBE	3
145H1301-161			D10007-06	D10006-06	FROM	TUBE ASSY	2
145H1301-163	D10019-06	—			TO	TUBE ASSY	2
145H1301-165			D10007-06	D10006-06	TO	TUBE ASSY	2
145H1301-169	D10007-04	D10006-04			FROM	TUBE ASSY	2
145H1302-1	D10021A-04	D10021A-04			TO	TUBE ASSY	2
145H1302-3	D10021A-04	D10021A-04			TO	TUBE ASSY	2
145H1302-5	D10021A-04	D10021A-04			TO	TUBE ASSY	2
145H1302-7	D10021A-04	D10021A-04			TO	TUBE ASSY	2
145H1302-9	D10007-06	D10006-06	D10007-06	D10006-06	TO	TUBE ASSY	2
145H1302-11					FROM	TUBE ASSY	2
145H1302-13					TO	TUBE ASSY	2
145H1302-18					FROM	TUBE	3
145H1302-20					FROM	TUBE	3
145H1302-21	D10007-06	D10006-06	D10007-06	D10006-06	TO	TUBE ASSY	2
145H1302-23			D10007-06	D10006-06	TO	TUBE ASSY	2
145H1302-25	D10007-06	D10006-06			FROM	TUBE ASSY	2
145H1302-27	D10019-06	—			FROM	TUBE ASSY	2
145H1302-29	D10019D12	—			TO	TUBE ASSY	2
145H1302-31	D10019-06	—			FROM	TUBE ASSY	2
145H1302-34					TO	TUBE	3
145H1302-35			D10019-06	—	TO	TUBE ASSY	2
145H1302-37	D10007-08	D10006-08			FROM	TUBE ASSY	2
145H1302-39			D10036-06	—	TO	TUBE ASSY	2
145H1302-41			D10019-06	—	TO	TUBE ASSY	2
145H1302-44					TO	TUBE	3
145H1302-46					FROM	TUBE	3
145H1302-47					FROM	TUBE ASSY	2
145H1302-50			D10019D12	—	FROM	TUBE	3
145H1302-51	D10007D10	D10006D10			TO	TUBE ASSY	2
145H1302-53			D10036D10		FROM	TUBE ASSY	2

C. TUBE ASSEMBLY DATA (SHEET 4 OF 13)

PART NUMBER	END X FITTING		END Y FITTING		FLOW REL TO X END	NOMEN-CLATURE	NOTES
	SLEEVE	NUT	SLEEVE	NUT			
145H1302-55			D10019D10	—	FROM	TUBE ASSY	2
145H1302-57			D10007D10	D10006D10	TO	TUBE ASSY	2
145H1302-59			D10045-0604	—	FROM	TUBE ASSY	2
145H1302-61	D10007-08	D10006-06			FROM	TUBE ASSY	2
145H1302-63			D10019-06	—	TO	TUBE ASSY	2
145H1302-66					FROM	TUBE	3
145H1302-67			D10007-04	D10006-04	TO	TUBE ASSY	2
145H1302-69	D10036-04	—			FROM	TUBE ASSY	2
145H1302-72					TO	TUBE	3
145H1302-73	D10036-04	—			TO	TUBE ASSY	2
145H1302-76					FROM	TUBE	3
145H1302-77			D10041-0806	—	FROM	TUBE ASSY	2
145H1302-79			D10007-06	D10006-06	FROM	TUBE ASSY	2
145H1302-82					TO	TUBE	3
145H1302-83			D10007-06	D10006-06	TO	TUBE ASSY	2
145H1302-86					—	TUBE	3
145H1302-88					FROM	TUBE	3
145H1302-89			D10007-06	D10006-06	TO	TUBE ASSY	2
145H1302-93			D10036-06	—	TO	TUBE ASSY	2
145H1302-95			D10007-06	D10006-06	FROM	TUBE ASSY	2
145H1302-97	D10041-0608	—			FROM	TUBE ASSY	2
145H1302-100					TO	TUBE	3
145H1302-103	D10019-04	—			TO	TUBE ASSY	2
145H1302-105			D10019-04	—	FROM	TUBE ASSY	2
145H1302-108					TO	TUBE	3
145H1302-109	D10021-04	—			FROM	TUBE ASSY	2
145H1302-112					FROM	TUBE	3
145H1302-114					TO	TUBE	3
145H1302-116					TO	TUBE	3
145H1302-117			D10019-06	—	TO	TUBE ASSY	2
145H1302-119	D10009-06	—			FROM	TUBE ASSY	2
145H1302-123			D10007-04	D10006-04	TO	TUBE ASSY	2
145H1302-125	D10019-04	—			FROM	TUBE ASSY	2

C. TUBE ASSEMBLY DATA (SHEET 5 OF 13)

PART NUMBER	END X FITTING		END Y FITTING		FLOW REL TO X END	NOMEN-CLATURE	NOTES
	SLEEVE	NUT	SLEEVE	NUT			
145H1302-127	D10036D10	—			FROM	TUBE ASSY	2
145H1401-2					TO	TUBE	3
145H1401-4					TO	TUBE	3
145H1401-5	D10036-06	—			FROM UNION	TUBE ASSY	2
145H1401-7	D10036-06	—			FROM	TUBE ASSY	2
145H1401-10					—	TUBE	3
145H1401-11	D10036-06	—			TO	TUBE ASSY	2
145H1401-14					—	TUBE	3
145H1401-15	D10036-06	—	D10007-06	D10006-06	FROM	TUBE ASSY	2
145H1401-17	D10036-06	—			TO	TUBE ASSY	2
145H1401-19	D10036-06	—			FROM	TUBE ASSY	2
145H1401-21	D10036-04	—			FROM	TUBE ASSY	2
145H1401-23	D10036-06	—			FROM	TUBE ASSY	2
145H1401-26					—	TUBE ASSY	2
145H1401-27	D10036-06	—			FROM	TUBE ASSY	2
145H1401-29	D10036-04	—			—	TUBE ASSY	2
145H1401-31	D10054-04	—			—	TUBE ASSY	2
145H1401-33			D10007-04	D10006-04	—	TUBE ASSY	2
145H1401-35	D10019-04	—			—	TUBE ASSY	2
145H1401-37			D10019-04	—	—	TUBE ASSY	2
145H1401-41			D10007-06	D10006-06	TO	TUBE ASSY	2
145H1401-43			D10007-04	D10006-04		TUBE ASSY	2
145H1401-45	D10007-04	D10006-04				TUBE ASSY	2
145H1401-46						TUBE ASSY	2
145H1401-49			D10019-04	—	—	TUBE ASSY	2
145H1401-51			D10007-04	D10006-04		TUBE ASSY	2
145H1401-53	D10036-04	—				TUBE ASSY	2
145H1401-57			D10041-0604	—	FROM	TUBE ASSY	2
145H1401-59			D10019-06	—	FROM	TUBE ASSY	2
145H1401-61	D10007-04	D10006-04			—	TUBE ASSY	2
145H1401-63	D10007-04	D10006-04	D10007-04	D10006-04	FROM	TUBE ASSY	2
145H1401-65			D10007-04	D10006-04	—	TUBE ASSY	2

C. TUBE ASSEMBLY DATA (SHEET 6 OF 13)

PART NUMBER	END X FITTING		END Y FITTING		FLOW REL TO X END	NOMEN-CLATURE	NOTES
	SLEEVE	NUT	SLEEVE	NUT			
145H1401-68					TO	TUBE	3
145H1401-70					TO	TUBE	3
145H1401-71			D10007-06	D10006-06	FROM	TUBE ASSY	2
145H1401-73			D10007-06	D10006-06	TO	TUBE ASSY	2
145H1401-75	D10007-04	D10006-04	D10007-04	D10006-04	—	TUBE ASSY	2
145H1401-77	D10007-04	D10006-04	D10007-04	D10006-04	—	TUBE ASSY	2
145H1401-79			D10019-06	—	TO	TUBE ASSY	2
145H1401-81					TO	TUBE ASSY	2
145H1402-2					TO	TUBE	3
145H1402-3	D10036-08	—			TO	TUBE ASSY	2
145H1402-5	D10036-06	—			TO	TUBE ASSY	2
145H1402-7	D10036-06	—			FROM	TUBE ASSY	2
145H1402-9	D10036-06	—			TO	TUBE ASSY	2
145H1402-11	D10036-06	—			TO	TUBE ASSY	2
145H1402-14					—	TUBE	3
145H1402-15	D10036-06				FROM UNION	TUBE ASSY	2
145H1402-17	D10036-08	—			TO	TUBE ASSY	2
145H1402-19	D10036-06	—			TO	TUBE ASSY	2
145H1402-21			D10007-06	D10006-08	FROM	TUBE ASSY	2
145H1402-23	D10045-0806	—	D10007-08	D10006-08	—	TUBE ASSY	2
145H1402-25			D10019-06	—	FROM	TUBE ASSY	2
145H1402-28					FROM	TUBE	3
145H1402-30					FROM	TUBE	3
145H1402-31			D10007-06	D10006-06	TO	TUBE ASSY	2
145H1402-33			D10007-06	D10006-06	FROM	TUBE ASSY	2
145H1801-1			D10019-06	—	TO	TUBE ASSY	2
145H1801-3	D10019-06	—			TO	TUBE ASSY	2
145H1801-5			D10019-06	—	FROM	TUBE ASSY	2
145H1801-7			D10019-06		FROM	TUBE ASSY	2
145H1801-9	D10036-04	—			—	TUBE ASSY	2
145H1801-13			D10019-04	—	—	TUBE ASSY	2
145H1801-15			D10019-04	—	—	TUBE ASSY	2

C. TUBE ASSEMBLY DATA (SHEET 7 OF 13)

PART NUMBER	END X FITTING		END Y FITTING		FLOW REL TO X END	NOMEN-CLATURE	NOTES
	SLEEVE	NUT	SLEEVE	NUT			
145H1801-17			D10153-04	—	—	TUBE ASSY	2
145H1801-19			D10036-04	—	TO	TUBE ASSY	2
145H1801-21			D10019-04	—	—	TUBE ASSY	2
145H1801-23	D10007-06	D10006-06			—	TUBE ASSY	2
145H1801-25			D10007-04	D10006-04	TO	TUBE	3
145H1801-27			D10036-04	—	FROM	TUBE	3
145H1801-29			D10036-04	—	TO	TUBE	3
145H1801-31	D10008-04	—	D10036-04	—	FROM	TUBE	3
145H1801-33			D10036-04	—	FROM	TUBE	3
145H1801-35			D10007-04	D10006-04	FROM	TUBE	3
145H1801-37	D10007-04	D10006-04	D10019-04	—	TO	TUBE	3
145H1801-40					TO	TUBE	3
145H1801-41			D10007-04	D10006-04	—	TUBE ASSY	2
145H1801-44					TO	TUBE	3
145H1801-45	D10019-04	—	D10019-04	—	TO	TUBE ASSY	2
145H1801-47	D10019-04	—	D10019-04	—	TO	TUBE ASSY	2
145H180-49	D10007-04	D10006-04	D10007-04	D10006-04	FROM	TUBE ASSY	2
145H1801-52					TO	TUBE	3
145H1801-54					FROM	TUBE	3
145H1801-55			D10019-04	—	FROM	TUBE ASSY	2
145H1801-57	D10036-04	—			FROM	TUB ASSY	2
145H1801-59	D10007-04	D10006-04			FROM	TUBE ASSY	2
145H1801-61	D10019-04	—			TO	TUBE ASSY	2
145H1801-63	D10019-04	—			TO	TUBE ASSY	2
145H1801-65	D10045-0604	—			TO	TUBE ASSY	2
145H1801-67			D10019-04	—	FROM	TUBE ASSY	2
145H1801-70					FROM	TUBE	3
145H1801-71	D10007-04	D10006-04			FROM	TUBE ASSY	2
145H1801-73	D10019-04	—			TO	TUBE ASSY	2
145H1801-75	D10019-04	—			TO	TUBE ASSY	2
145H1801-77			D10036-04	—	FROM	TUBE ASSY	2
145H1801-79	D10007-12	D10006-12			FROM	TUBE ASSY	2
145H1801-81			D10007-12	D10006-12	FROM	TUBE ASSY	2

C. TUBE ASSEMBLY DATA (SHEET 8 OF 13)

PART NUMBER	END X FITTING		END Y FITTING		FLOW REL TO X END	NOMEN-CLATURE	NOTES
	SLEEVE	NUT	SLEEVE	NUT			
145H1801-83			D10019-04	—	—	TUBE ASSY	2
145H1801-85			D10007-04	D10006-04	FROM	TUBE ASSY	2
145H1801-88					TO	TUBE	3
145H1801-89	D10007-04	D10006-04			FROM	TUBE ASSY	2
145H1801-91			D10019-04	—	FROM	TUBE ASSY	2
145H1801-93			D10007-04	D10006-04	TO	TUBE ASSY	2
145H1801-95	D10007-04	D10006-04			—	TUBE ASSY	2
145H1801-97			D10019-04	—	FROM	TUBE ASSY	2
145H1801-99			D10007-10	D10006-10	TO	TUBE ASSY	2
145H1801-101	D10007-04	D10006-04			—	TUBE ASSY	2
145H1801-103			D10007-04	D10006-04	TO	TUBE ASSY	2
145H1801-106	D10007-04	D10006-04			—	TUBE	3
145H1801-107			D10007-06	D10006-06	FROM	TUBE ASSY	2
145H1901-111			D10019-04	—	FROM	TUBE ASSY	2
145H1801-113	D10019-04	—			FROM	TUBE ASSY	2
145H1801-131			D10036-08	—	FROM	TUBE ASSY	2
145H1801-135			D10007-06	D10006-06	FROM	TUBE ASSY	2
145H1801-141			D10007-06	D10006-06	FROM	TUBE ASSY	2
145H1801-143			D10019-06	—	TO	TUBE ASSY	2
145H1801-145	D10007-04	D10006-04			FROM	TUBE ASSY	2
145H1801-150					TO	TUBE	3
145H1801-152					FROM	TUBE	3
145H1801-153	D10007-04	D10006-04	D10007-04	D10006-04	FROM	TUBE ASSY	2
145H1801-156					TO	TUBE	3
145H1801-157	D10036-04	—			FROM	TUBE ASSY	2
145H1801-160					TO	TUBE	3
145H1801-161			D10019-10	—	TO	TUBE ASSY	2
145H1801-163			D10007-10	D10006-10	FROM	TUBE ASSY	2
145H1801-165			D10007-10	D10006-10	TO	TUBE ASSY	2
145H1801-167	D10007-04	D10006-04			TO	TUBE ASSY	2
145H1801-169			D10019-04	—	TO	TUBE ASSY	2
145H1801-171	D10019-08	—			TO	TUBE ASSY	2
145H1801-173			D10007-08	D10006-08	FROM	TUBE ASSY	2

C. TUBE ASSEMBLY DATA (SHEET 9 OF 13)

PART NUMBER	END X FITTING		END Y FITTING		FLOW REL TO X END	NOMEN-CLATURE	NOTES
	SLEEVE	NUT	SLEEVE	NUT			
145H1801-175			D10007-06	D10006-06	TO	TUBE ASSY	2
145H1801-177			D10007-10	D10006-10	FROM	TUBE ASSY	2
145H1801-180					FROM	TUBE	3
145H1801-181	D10019-04	—	D10019-04	—	TO	TUBE ASSY	2
145H1801-183	D10007-04	D10006-04			TO	TUBE ASSY	2
145H1801-187	D10019-04	—	D10019-04	—	TO	TUBE ASSY	2
145H1801-191	D10007-04	D10006-04			TO	TUBE ASSY	2
145H1801-196					FROM	TUBE	3
145H1801-197			D10007-08	D10006-08	FROM	TUBE ASSY	2
145H1801-199			D10019-008	—	TO	TUBE ASSY	2
145H1801-201			D10007-08	—	TO	TUBE ASSY	2
145H1801-206					FROM	TUBE	3
145H1801-208					FROM	TUBE	3
145H1801-211			D10019-04	—	TO	TUBE ASSY	2
145H1801-213			D10019-04	—	TO	TUBE ASSY	2
145H1801-215	D10008-04	—	D10008-04		TO	TUBE ASSY	2
145H1801-217	D10008-04	—	D10008-04	—	TO	TUBE ASSY	2
145H1801-219	D10008-04	—	D10008-04	—	TO	TUBE ASSY	2
145H1801-221	D10007-04	D10006-04	D10007-04	D10006-04	TO	TUBE ASSY	2
145H1801-223	D10007-04	—	D10006-04	—	—	TUBE ASSY	2
145H1801-225	D10008-04	—	D10008-04	—	—	TUBE ASSY	2
145H1801-227	D10008-04	—	D10008-04	—	TO	TUBE ASSY	2
145H1801-229	D10008-04	—	D10008-04	—	FROM	TUBE ASSY	2
145H1801-231	D10007-04	D10006-04			—	TUBE ASSY	2
145H1801-233	D10007-04	D10006-04	D10007-04	D10006-04	TO	TUBE ASSY	2
145H1801-235	D10007-08	D16006-08			TO	TUBE ASSY	2
145H1801-237	D10007-06	D10006-06			FROM	TUBE ASSY	2
145H1801-239			D10007-12	D10006-12	TO	TUBE ASSY	2
145H1801-241	D10007-12	D10006-12			FROM	TUBE ASSY	2
145H1801-243			D10019-12	—	FROM	TUBE ASSY	2
145H1801-245	D10007-08	D10006-08	D10007-08		TO	TUBE ASSY	2
145H1801-247			D10007-04	D10006-04	FROM	TUBE ASSY	2
145H1801-250					TO	TUBE	3

C. TUBE ASSEMBLY DATA (SHEET 10 OF 13)

PART NUMBER	END X FITTING		END Y FITTING		FLOW REL TO X END	NOMEN-CLATURE	NOTES
	SLEEVE	NUT	SLEEVE	NUT			
145H1801-251	D10007-04	D10006-04			TO	TUBE ASSY	2
145H1801-253	D10019-04	—	D10019-04	—	TO	TUBE ASSY	2
145H1801-256					TO	TUBE	3
145H1801-257			D10007-06	D10006-06	FROM	TUBE ASSY	2
145H1801-261	D10019-06	—	D10019-06	—	FROM	TUBE ASSY	2
145H1801-263			D10019-06	—	FROM	TUBE ASSY	2
145H1801-267					FROM	TUBE ASSY	2
145H1801-269	D10007-06	D10006-06			TO	TUBE ASSY	2
145H1802-271			D10041-0604	—	FROM	TUBE ASSY	2
145H1802-1	D10007-06	D10006-06			FROM	TUBE ASSY	2
145H1802-3	D10019-06	—			FROM	TUBE ASSY	2
145H1802-5			D10019-08	—	TO	TUBE ASSY	2
145H1802-7			D10007-06	D10006-06	TO	TUBE ASSY	2
145H1802-9	D10019-06	—			TO	TUBE ASSY	2
145H1802-11			D10007-06	D10006-06	TO	TUBE ASSY	2
145H1802-14					TO	TUBE	3
145H1802-15			D10007D10	D10006D10	FROM	TUBE ASSY	2
145H1802-17	D10007-06	D10006-06			TO	TUBE ASSY	2
145H1802-20					TO	TUBE	3
145H1802-22					FROM	TUBE	3
145H1802-24					TO	TUBE	3
145H1802-25			D10036-06	—	TO	TUBE ASSY	2
145H1802-27	D10045-0604	—			FROM	TUBE ASSY	2
145H1802-29	D10036-06	—			TO	TUBE ASSY	2
145H1802-33			D10007-06	D10006-06	FROM	TUBE ASSY	2
145H1802-35			D10007D10	D10006D10	TO	TUBE ASSY	2
145H1802-38					FROM	TUBE	3
145H1802-40					FROM	TUBE	3
145H1802-41	D10019D12	—			TO	TUBE ASSY	2
145H1802-43			D10007D12	D10006D12	TO	TUBE ASSY	2
145H1802-45	D10019D12	—			FROM	TUBE ASSY	2
145H1802-47	D10007D12	D10006D12			TO	TUBE ASSY	2
145H1802-49	D10019D12		D10007D12	BACN10ZA12D	TO	TUBE ASSY	2

C. TUBE ASSEMBLY DATA (SHEET 11 OF 13)

PART NUMBER	END X FITTING		END Y FITTING		FLOW REL TO X END	NOMEN-CLATURE	NOTES
	SLEEVE	NUT	SLEEVE	NUT			
145H1802-51			D10007-08	D10006-08	FROM	TUBE	3
145H1802-53	D10036D10	—			FROM	TUBE ASSY	2
145H1802-55			D10019D10	—	TO	TUBE ASSY	2
145H1802-57			D10007D10	D10006D10	STRAIGHT TO	TUBE ASSY	2
145H1802-60					TO	TUBE	3
145H1802-62					TO	TUBE	3
145H1802-67	D10036-06	—			FROM	TUBE ASSY	2
145H1802-70					TO	TUBE	3
145H1802-71	D10007D12	D10006D12			TO	TUBE ASSY	2
145H1802-73			D10007-06	D10006-06	TO	TUBE ASSY	2
145H1802-75	D10007-08	D10006-08			FROM	TUBE ASSY	2
145H1802-77	D10007-08	D10006-08			FROM	TUBE ASSY	2
145H1802-79			D10007D10	D10006D10	TO	TUBE ASSY	2
145H1802-81	D10019D10	—	D10007D10	D10006D10	FROM	TUBE ASSY	2
145H1802-83	D10007D16	D10006D16			TO	TUBE ASSY	2
145H1802-86					TO	TUBE	2
145H1802-87	D10007-06	D10006-06			FROM	TUBE ASSY	3
145H1802-89			D10007-06	D10006-06	FROM	TUBE ASSY	2
145H1802-91	D10019D12	—			TO	TUBE ASSY	2
145H1802-93			D10007-04	D10006-04	TO	TUBE ASSY	2
145H1802-97	D10041-0608	—			FROM	TUBE ASSY	2
145H1802-99			D10007-06	D10006-06	TO	TUBE ASSY	2
145H1802-103	D10019-06		D10019-06		TO	TUBE ASSY	2
145H1802-105			D10041-0608	—	TO	TUBE ASSY	2
145H1802-107			D10019-06		TO	TUBE ASSY	2
145H1802-109			D10007-06	D10006-06	FROM	TUBE ASSY	2
145H1802-111	D10036-04	—			FROM	TUBE ASSY	2
145H1802-117	D10007-04	D10006-04	D10019-04	—	FROM	TUBE ASSY	2
145H1802-119	D10007-04	D10006-04			FROM	TUBE ASSY	2
145H1802-122					TO	TUBE	3
145H1802-123			D10045-0406	—	FROM	TUBE ASSY	2
145H1802-125	D10007-04	D10006-04			FROM	TUBE ASSY	2

C. TUBE ASSEMBLY DATA (SHEET 12 OF 13)

PART NUMBER	END X FITTING		END Y FITTING		FLOW REL TO X END	NOMEN-CLATURE	NOTES
	SLEEVE	NUT	SLEEVE	NUT			
145H1802-127	D10019-04	—			TO	TUBE ASSY	2
145H1802-129	D10007-04	D10006-04	D10019-04	—	TO	TUBE ASSY	2
145H1802-133	D10036-04	—			TO	TUBE ASSY	2
145H1802-136					FROM	TUBE	3
145H1802-137			D10007-04	D10006-04	TO	TUBE ASSY	2
145H1802-139	D10038-04				FROM	TUBE ASSY	2
145H1802-141	D10036-04	—			TO	TUBE ASSY	2
145H1802-143			D10007-04	D10006-04	FROM	TUBE ASSY	2
145H1802-147			D10019-04	—	FROM	TUBE ASSY	2
145H1802-149			D10007-04	D10006-04	TO	TUBE ASSY	2
145H1802-151			D10007-04	D10006-04	FROM	TUBE ASSY	2
145H1802-153			D10007-04	D10006-04	TO	TUBE ASSY	2
145H1802-164					FROM	TUBE	3
145H1802-165			D10019-04	—	FROM	TUBE ASSY	2
145H1802-167					TO	TUBE ASSY	2
145H1802-169					TO	TUBE ASSY	2
145H1802-171					TO	TUBE ASSY	2
145H1802-173					TO	TUBE ASSY	2
145H1802-175			D10059D16	—	TO	TUBE ASSY	2
145H1802-177			D10059D16	—	TO	TUBE ASSY	2
145H1802-179			D10007-06	D10006-06	FROM	TUBE ASSY	2
145H1802-181	D10059D16	—			FROM	TUBE ASSY	2
145H1802-183	D10041-0608	—			TO	TUBE ASSY	2
145H1802-188					FROM	TUBE	3
145H1802-189	D10007-06	D10006-06			FROM	TUBE ASSY	2
145H1802-191	D10007D10	D10006D10			TO	TUBE ASSY	2
145H1802-193			D10019-04	—	TO	TUBE ASSY	2
145H1802-197	D10007D12	D10006D12			FROM	TUBE ASSY	2
145H1802-200					TO	TUBE	3
145H1803-1			D10007-08	D10006-08	TO	TUBE ASSY	2
145H1803-6					FROM	TUBE	3
145H1803-11	D10007-08	D10006-08			FROM	TUBE	3
145H1803-14					FROM	TUBE ASSY	2

C. TUBE ASSEMBLY DATA (SHEET 13 OF 13)

PART NUMBER	END X FITTING		END Y FITTING		FLOW REL TO X END	NOMEN-CLATURE	NOTES
	SLEEVE	NUT	SLEEVE	NUT			
145H1803-15			D10007-04	D10006-04	TO	TUBE	3
145H1803-17			D10007-08	D10006-08	FROM	TUBE ASSY	2
145H1803-23	D10007-08	D10006-08			FROM	TUBE ASSY	2
145H1803-25	D10019-06	—	D10019-06	—	TO	TUBE ASSY	2
145H1803-27	D10007-06	D10006-06	D10019-06	—	FROM	TUBE ASSY	2
145H1804-1			D10007-08	D10006-08	FROM	TUBE ASSY	2
145H1804-3			D10019D12	—	TO	TUBE ASSY	2
145H1804-5	D10007-08	D10006-08	D10007-08	D10006-08	TO	TUBE ASSY	2
145H1804-7			D10007-08	D10006-08	TO	TUBE ASSY	2
145H1804-10					TO	TUBE	3
145H1804-12					TO	TUBE	3
145H1804-19	BACE21BW12D				TO	TUBE ASSY	3
145H1804-21	D10019D16	—			TO	TUBE ASSY	2
145H1804-24					TO	TUBE	3
145H1804-25			D10007-06	D10006-06	TO	TUBE ASSY	2
145H1804-27	D10019-06	—	D10019-06	—	TO	TUBE ASSY	2
145H1804-29	D10007-06	D10006-06	D10019-06	—	TO	TUBE ASSY	2
145H1804-31			D10007-04	D10006-04	TO	TUBE ASSY	2
145H1804-33	D10021A-04	—			TO	TUBE ASSY	2
145H1804-35	D10007-06	D10006-06	D10045-0604	—	TO	TUBE ASSY	2
145P0171-1	—	—	—	NAS593-16	TO	TUBE ASSY	—
145P0171-2	—	—	—	NAS593-16	TO	TUBE ASSY	—

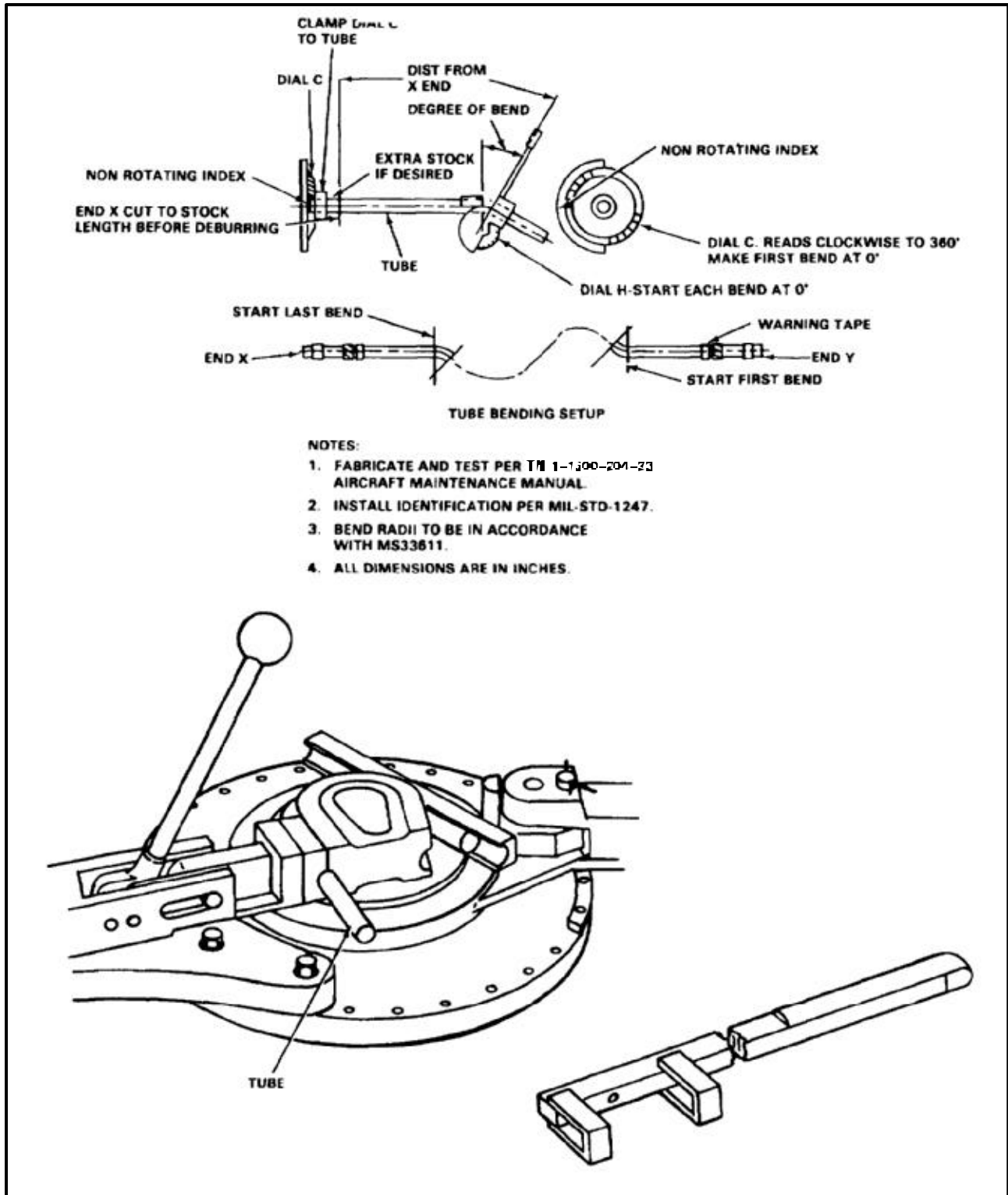

END OF TASK

NOTES:

1. FABRICATE FROM 4130 STEEL (E369.1) AND WHITE ASH WOOD (E160.2).
2. ALL DIMENSIONS IN INCHES.
3. TOLERANCES:

.X = ± .1
 ±.XX = .02

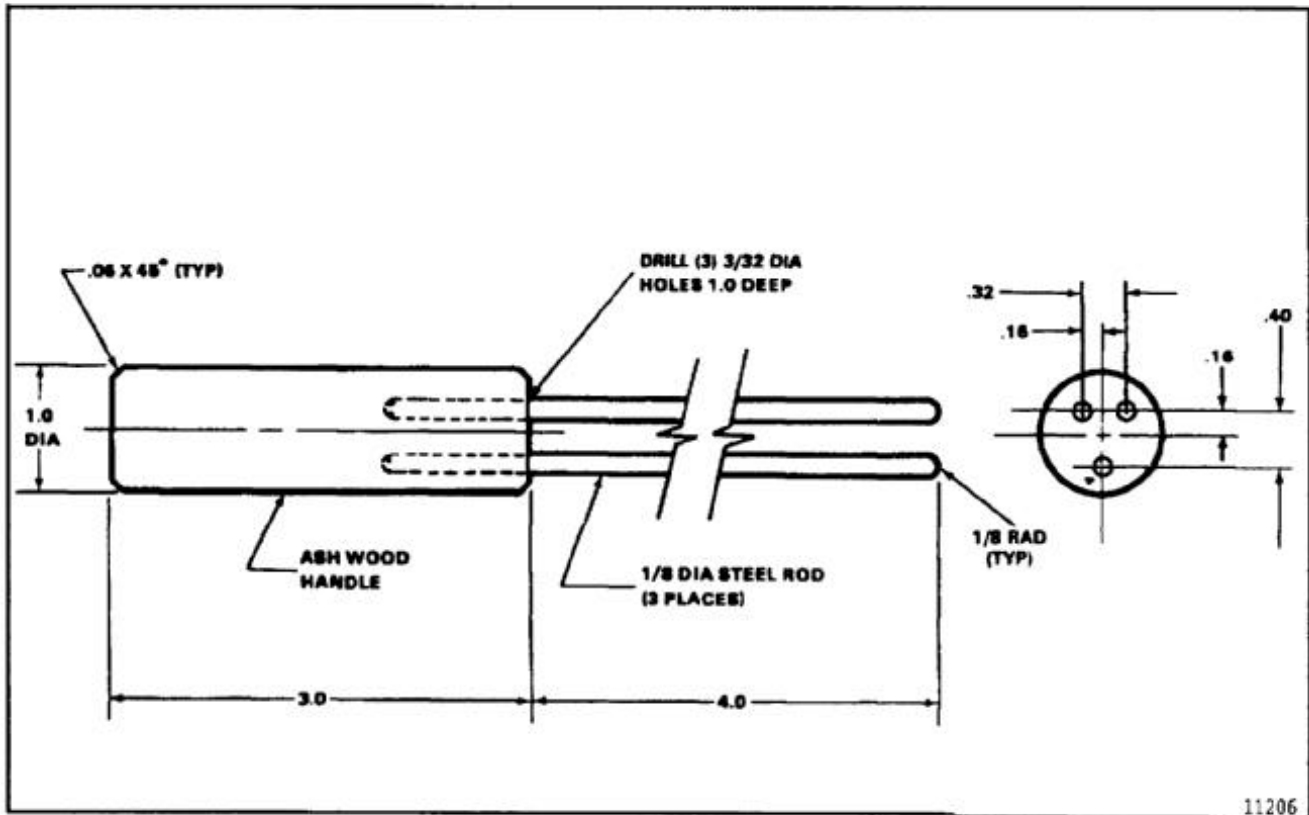

11206

END OF TASK

NOTES:

1. FABRICATE FROM NYLON OR DELRIN PLASTIC (E160.3).
2. ALL DIMENSIONS IN INCHES.
3. TOLERANCES:

.X = $\pm .1$
 $\pm .XX = .03$
 $\pm .XXX = .010$

ANGLES: $\pm 2^\circ$

4. BREAK ALL EDGES TO .04 MIN.

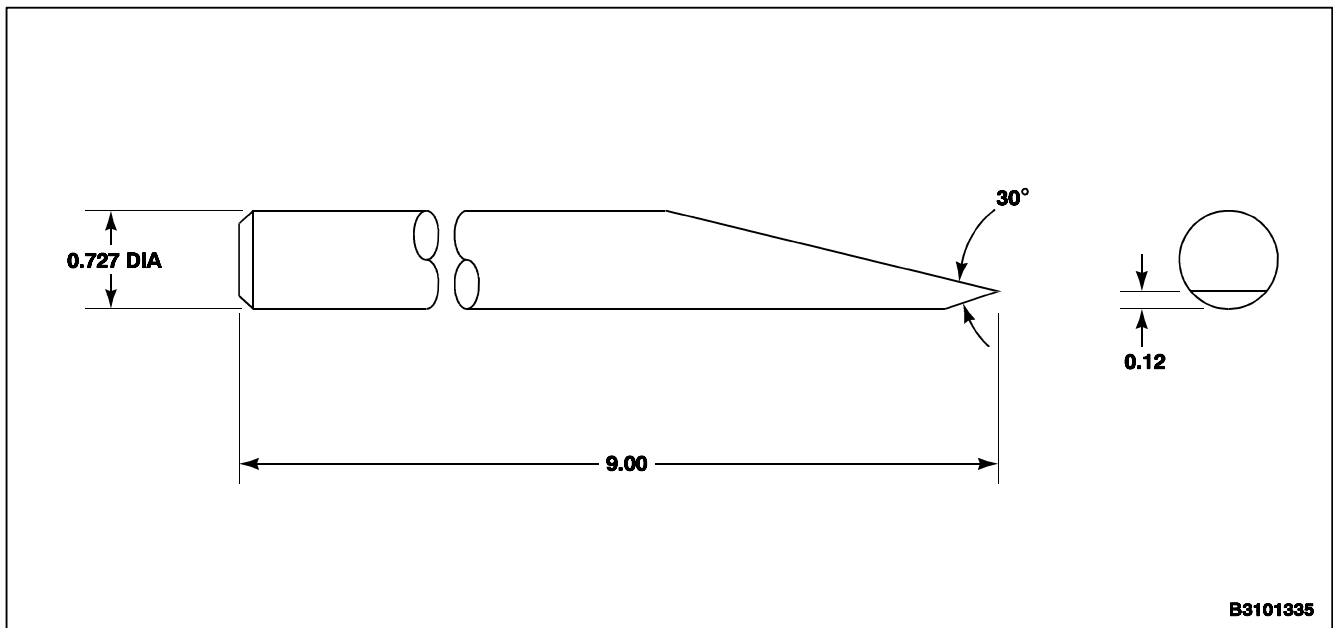

END OF TASK

PREFERRED

1. ALL DIAMETERS CONCENTRIC WITHIN 0.005 (TIR) TOTAL INDICATOR READING.
2. MACHINE FINISH 32 AA.
3. CADMIUM PLATE PER QQ-P-416.
4. HEAT TREAT 145L2330-2, -3 TO 150-170 KSI UTS. HEAT TREAT SK31250 TO 180-200 KSI UTS.
5. MATERIAL: 4340 STEEL BAR PER AMS 6415 OR MIL-S-5000 (E366.1).
6. BREAK SHARP EDGES 0.005 MAX.

ALTERNATE

1. MATERIAL: 4340 CONDITION N.
2. ALL DIAMETERS CONCENTRIC WITHIN 0.005 TIR.
3. BREAK SHARP EDGES 0.005 MAX.

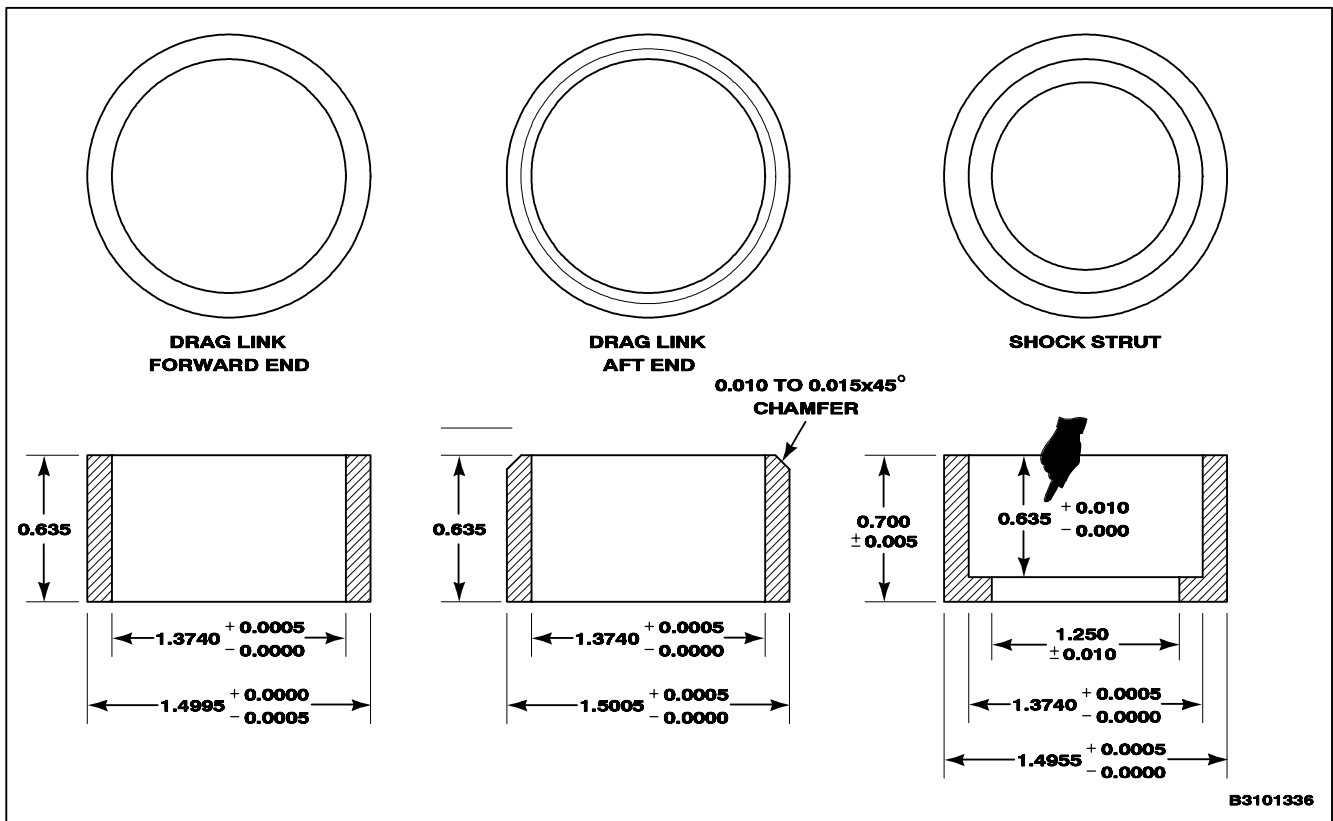

END OF TASK

NOTES:

1. FABRICATE FROM 9330-00-421-4218.
2. ALL DIMENSIONS IN INCHES.

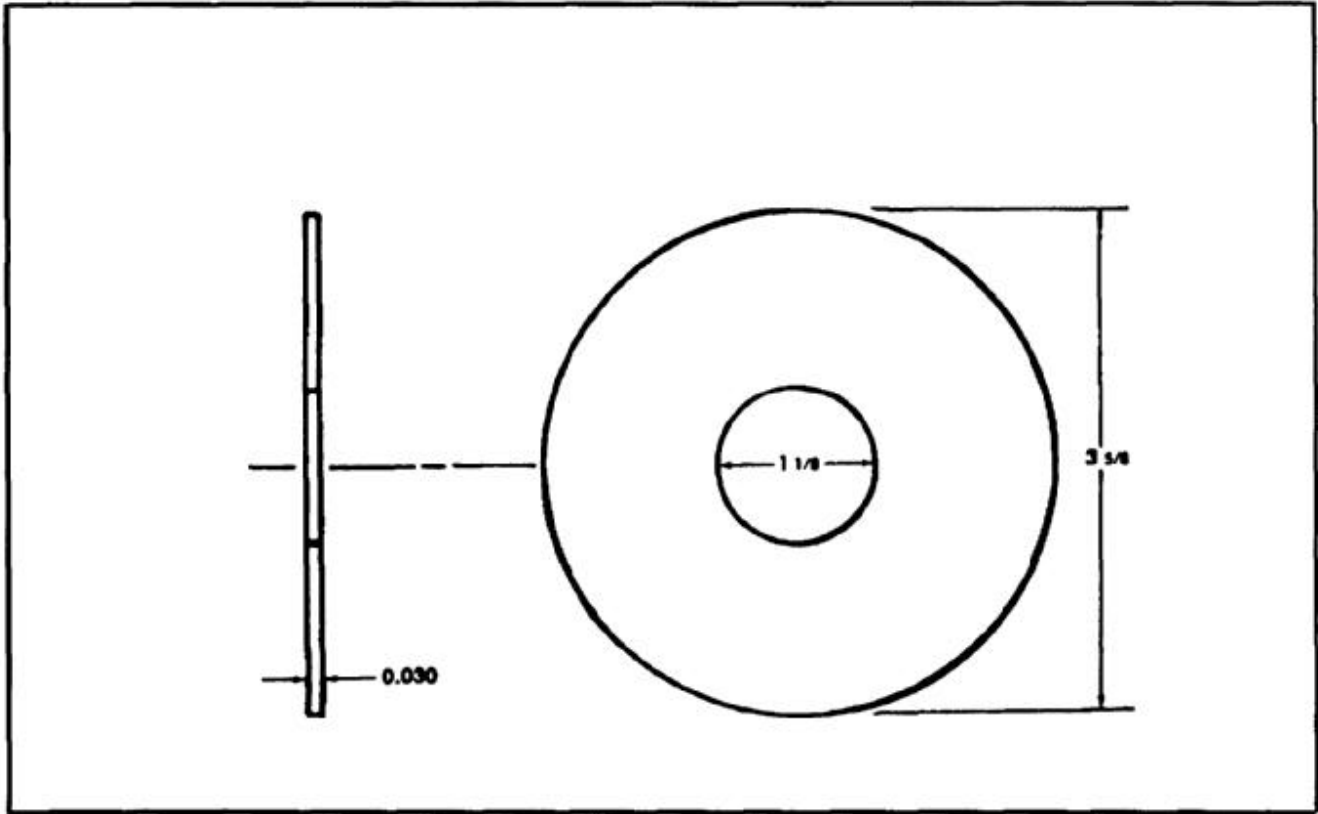

END OF TASK

NOTES:

1. THIS SKETCH IS FOR LOCAL MANUFACTURE OF A PLUG TO BE USED IN PLACE OF 114P5S09-1 DRAIN VALVE.
2. BREAK ALL SHARP EDGES.
3. TOLERANCES:
 $\pm.X$ 0.1
 $\pm.XX$ 0.03
 $\pm.XXX$ 0.010
 EXCEPT AS NOTED.
4. PLUG MATERIAL: 2024-T3 AL ALY OR EQUIVALENT.
5. ALL DIMENSIONS IN INCHES.

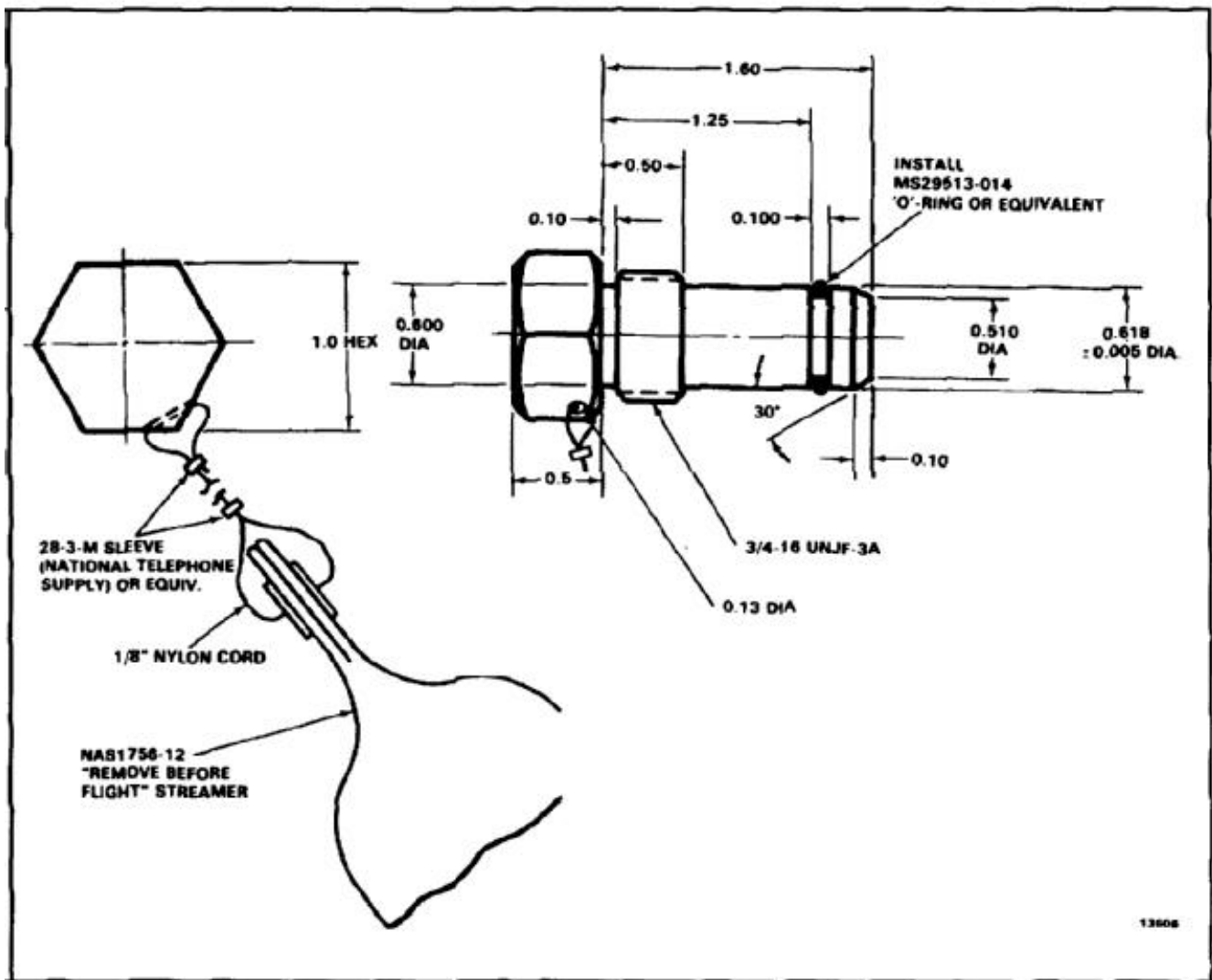

END OF TASK

NOTES:

1. FABRICATE FROM ALUMINUM.
2. ALL DIMENSIONS IN INCHES.
3. BREAK ALL SHARP EDGES 0.030 TO 0.060.

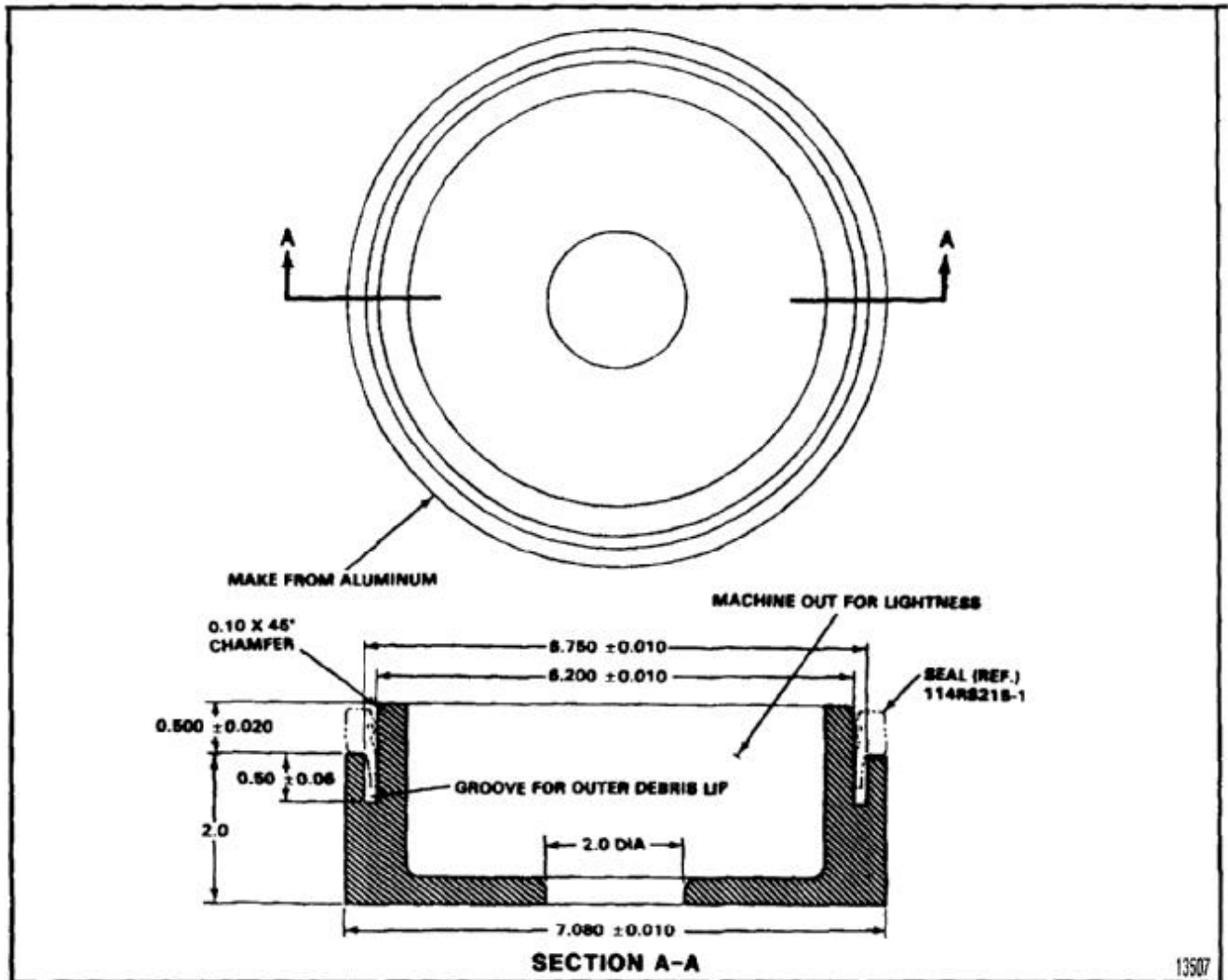

END OF TASK

NOTES:

1. FABRICATE FROM A DEEP, 12 POINT, 1-3/8 INCH SOCKET WITH 1/2 INCH DRIVE.
2. ALL DIMENSIONS IN INCHES.
3. \pm MACHINE DIMENSIONS TO 0.03 INCH.
4. REMOVE ALL SHARP EDGES.

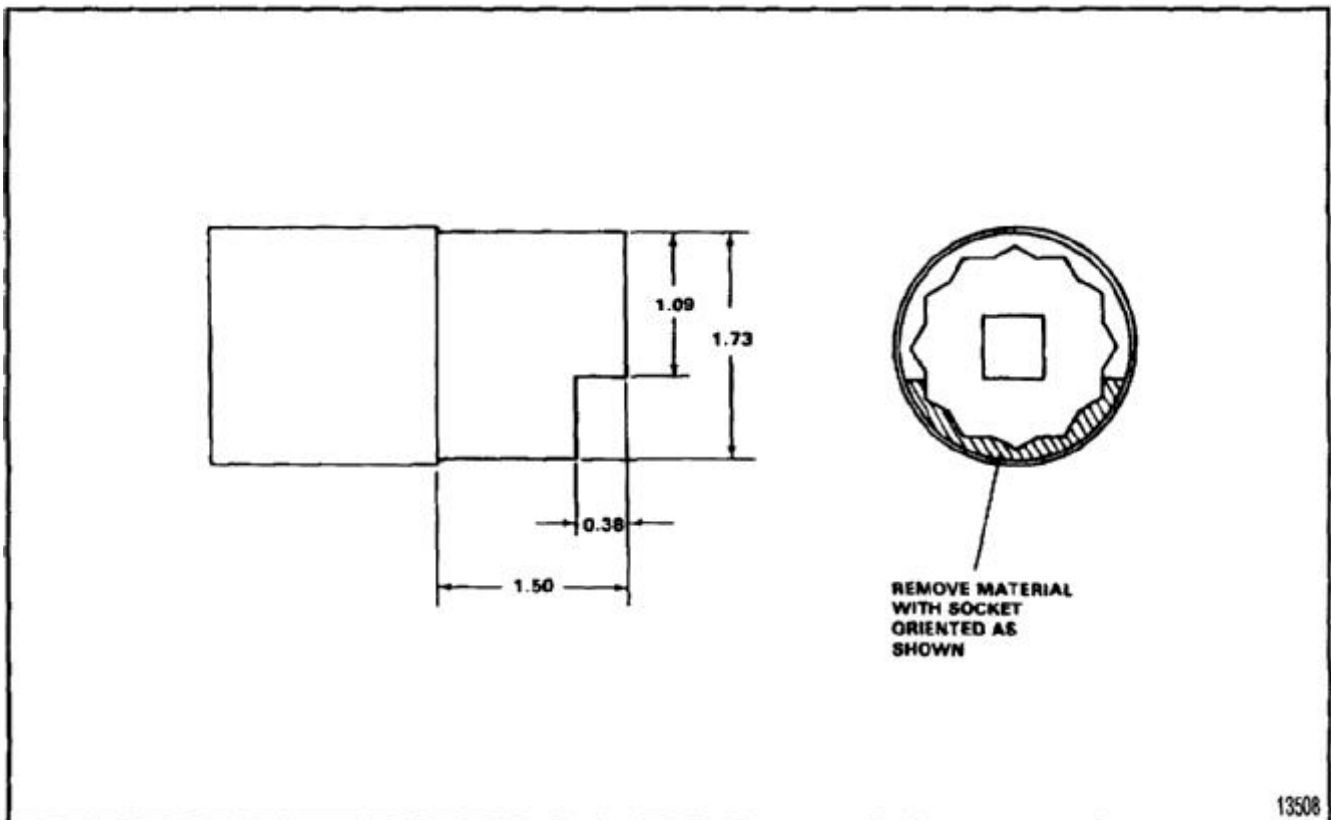

END OF TASK

NOTES:

1. BAC1521-350 SILICONE RUBBER.
FABRICATED FROM ZZ-R-769/19 AND
ZZ-R-765/GEN.
2. ALL DIMENSIONS IN INCHES.
3. CUT REPLACEMENT SEAL TO SAME LENGTH
AS ORIGINAL.

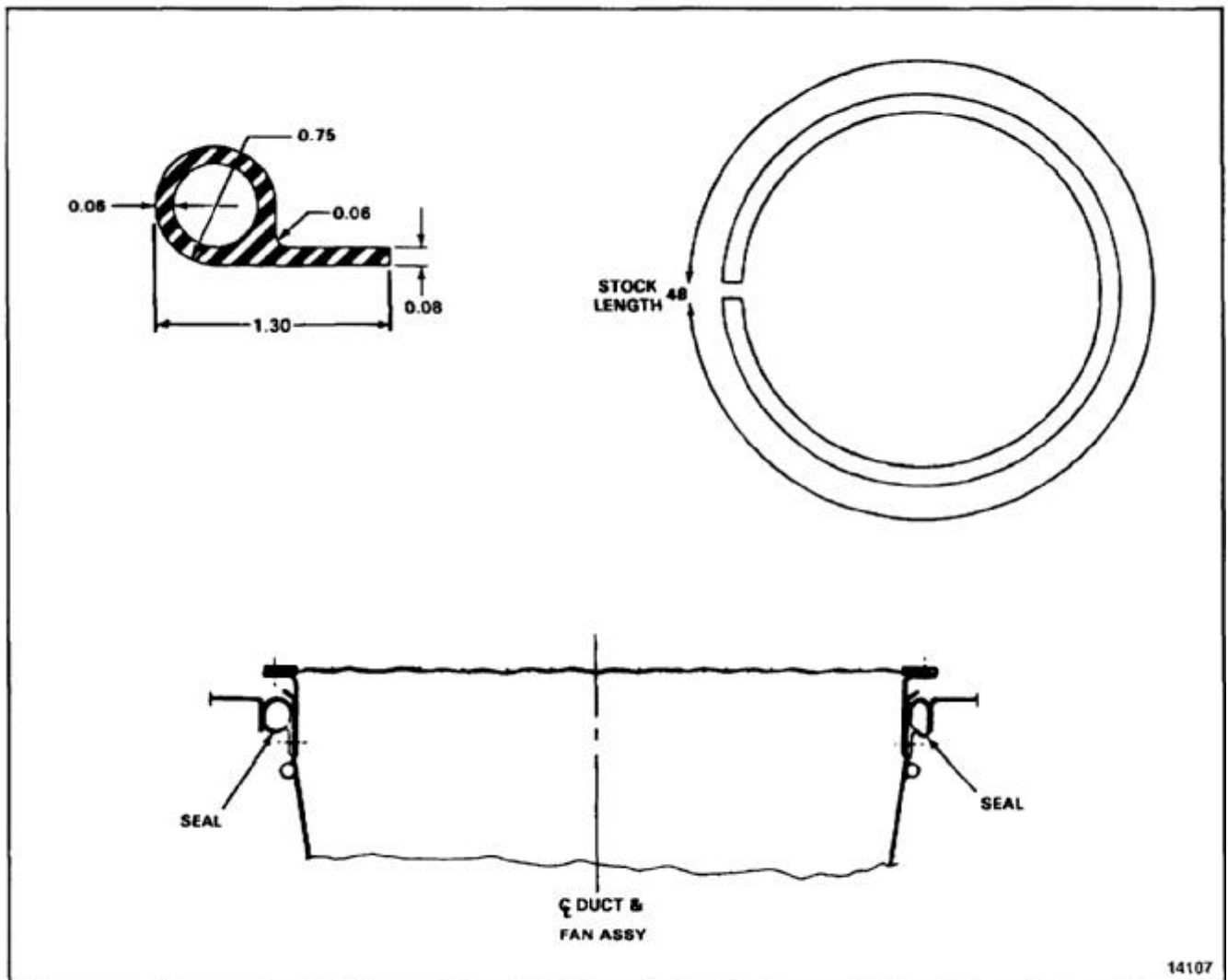

END OF TASK

NOTES:

1. FABRICATE FROM MS20001CH6-250.
2. STAKE BOTH ENDS OF HINGE -9 TO SPECIFICATIONS OF MS33540 IF HINGE PIN IS MADE FROM MS20253P2-250.
3. CRIMP END OF EACH HINGE HALF 0.25 INCH TO AN OPENING OF 0.05 IF PIN IS MADE FROM MS20253P2-198.
4. LEAVE AN OPENING IN CRIMPED HOLE SO THAT IT CAN SPREAD IF NECESSARY TO REMOVE PIN.
5. REFER TO E-60.
6. ALL DIMENSIONS IN INCHES.
7. FINISH ENDS OF PIN WITH ZINC CHROMATE PRIMER (E-290).
8. FINISH HINGE TO MIL-L-19538 AND MIL-F-1824.

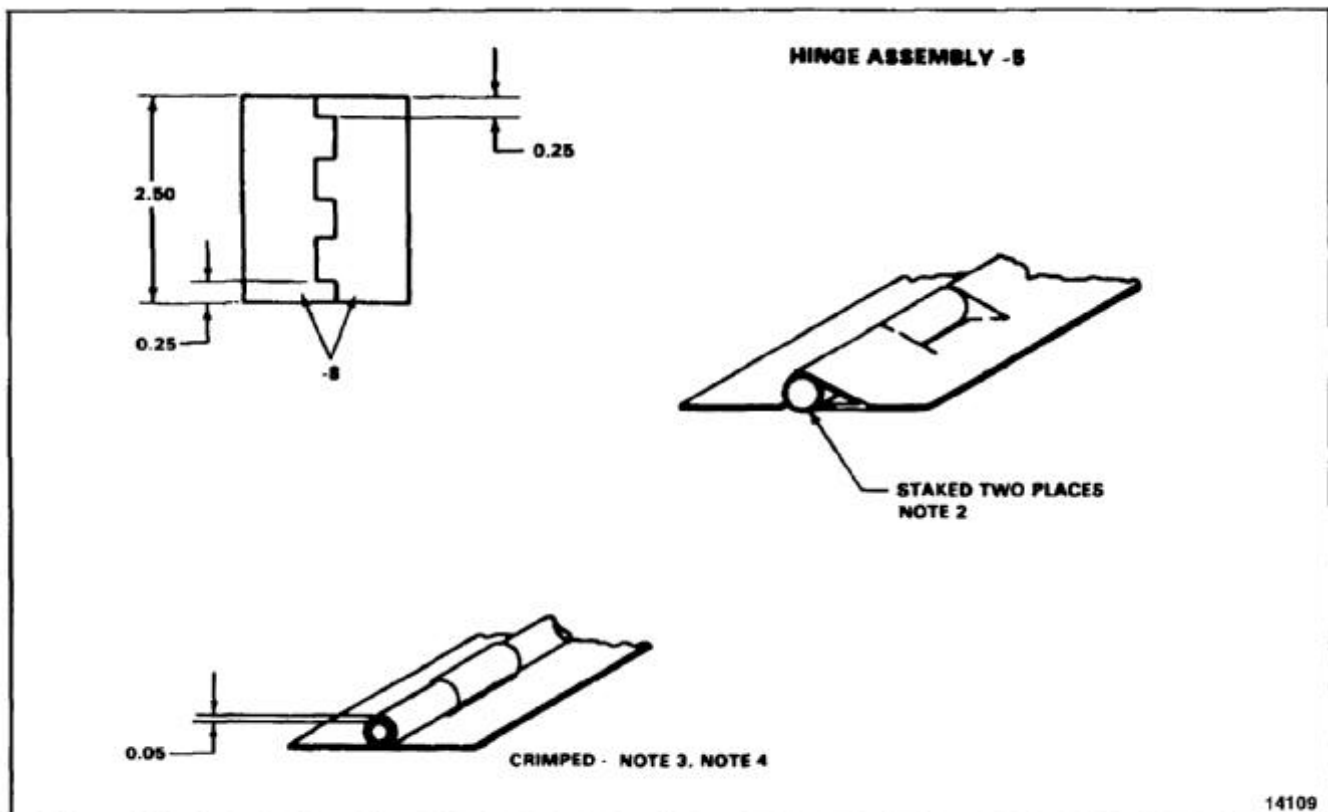

END OF TASK

NOTES:

1. FABRICATE FROM MS20253P2-198 (PREFERRED) OR MS20253P2-250.
2. REFER TO E-59.
3. ALL DIMENSIONS IN INCHES.

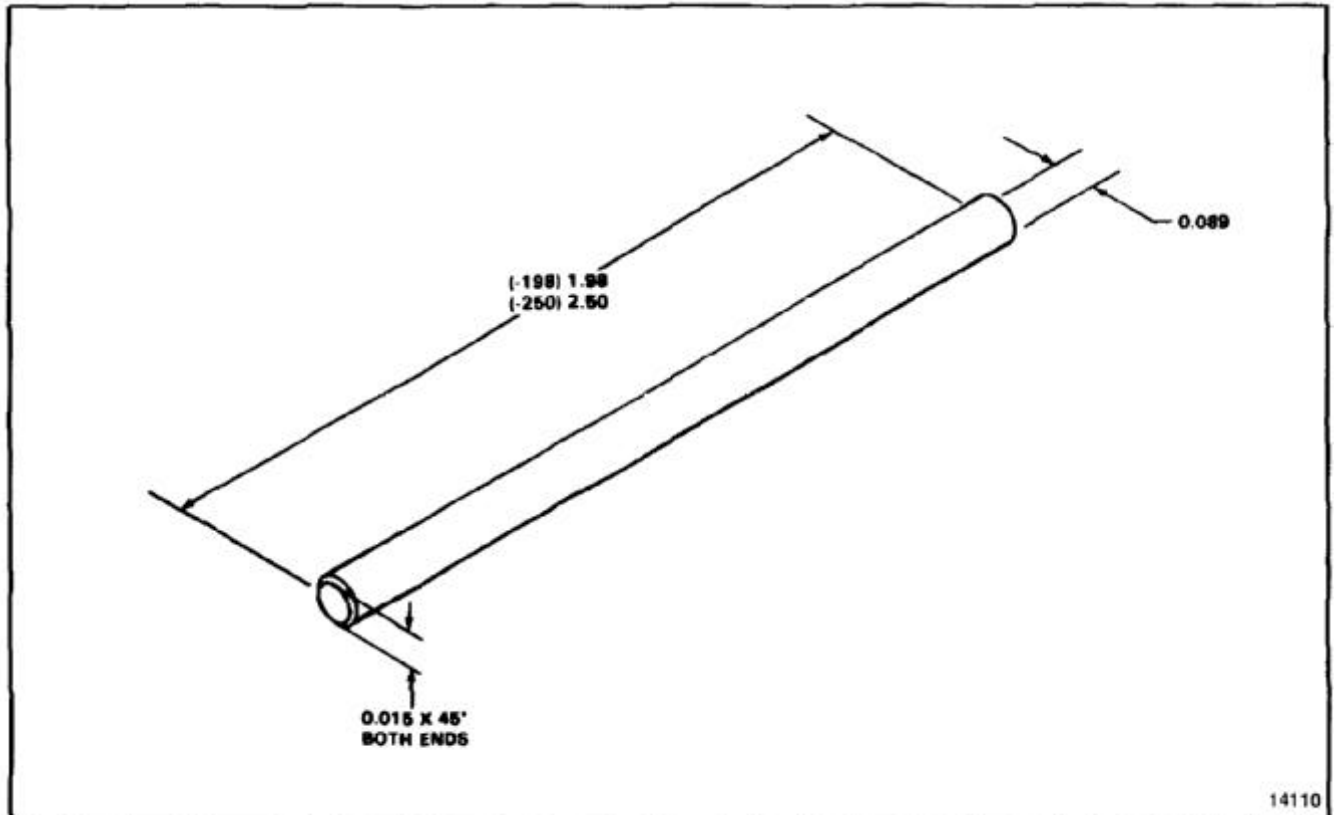

END OF TASK

NOTES:

1. FABRICATE FROM STOCK MATERIAL 301 CRES SHEET MIL-S-5059.
2. ALL DIMENSIONS IN INCHES.
3. FINISH AS REQUIRED.

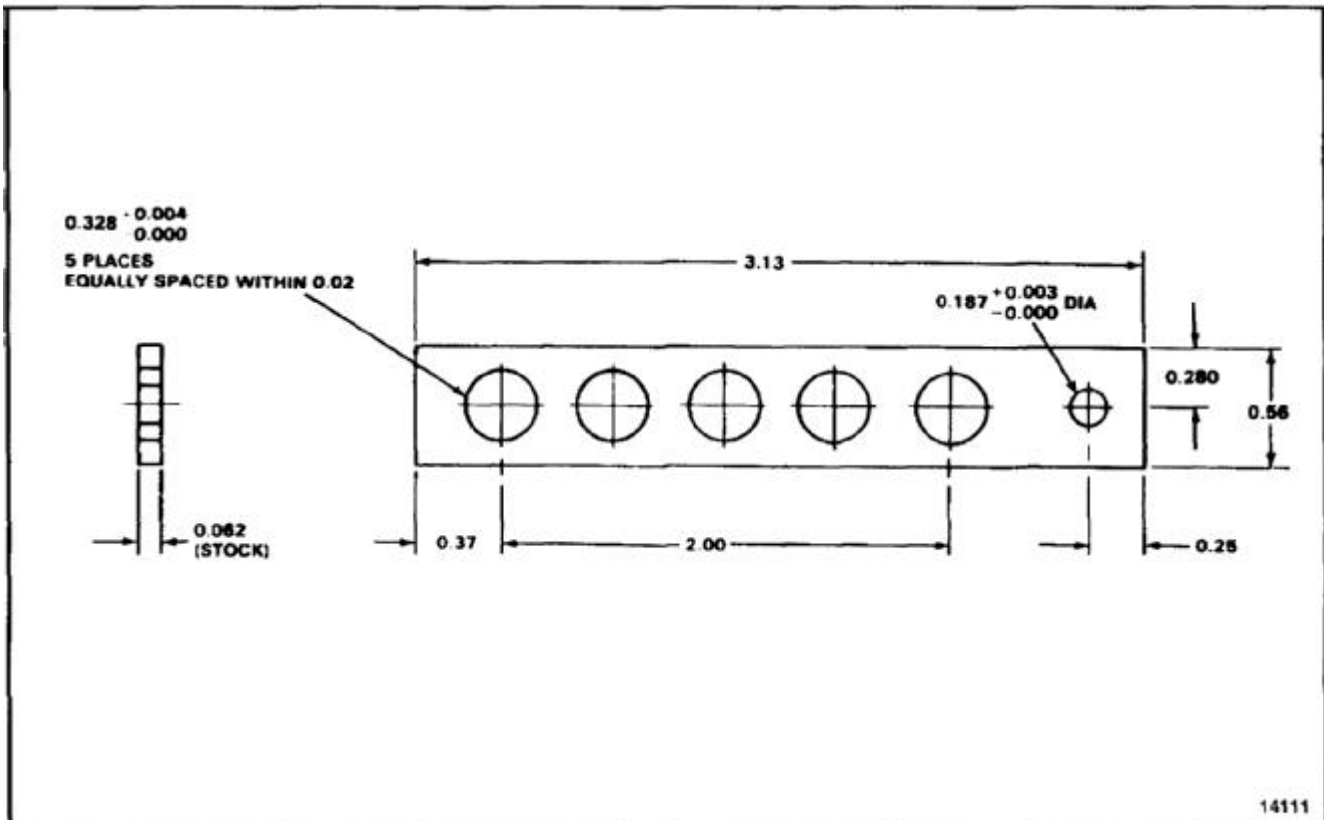

END OF TASK

NOTES:

1. FABRICATE FROM RUBBER TUBING MIL-R-6855, CLASS II GR40.
2. ALL DIMENSIONS IN INCHES.
3. LENGTH OF REPLACEMENT IS SAME AS ORIGINAL PART.
4. STOCK SIZE 0.437 OD X 0.312 ID X 15.

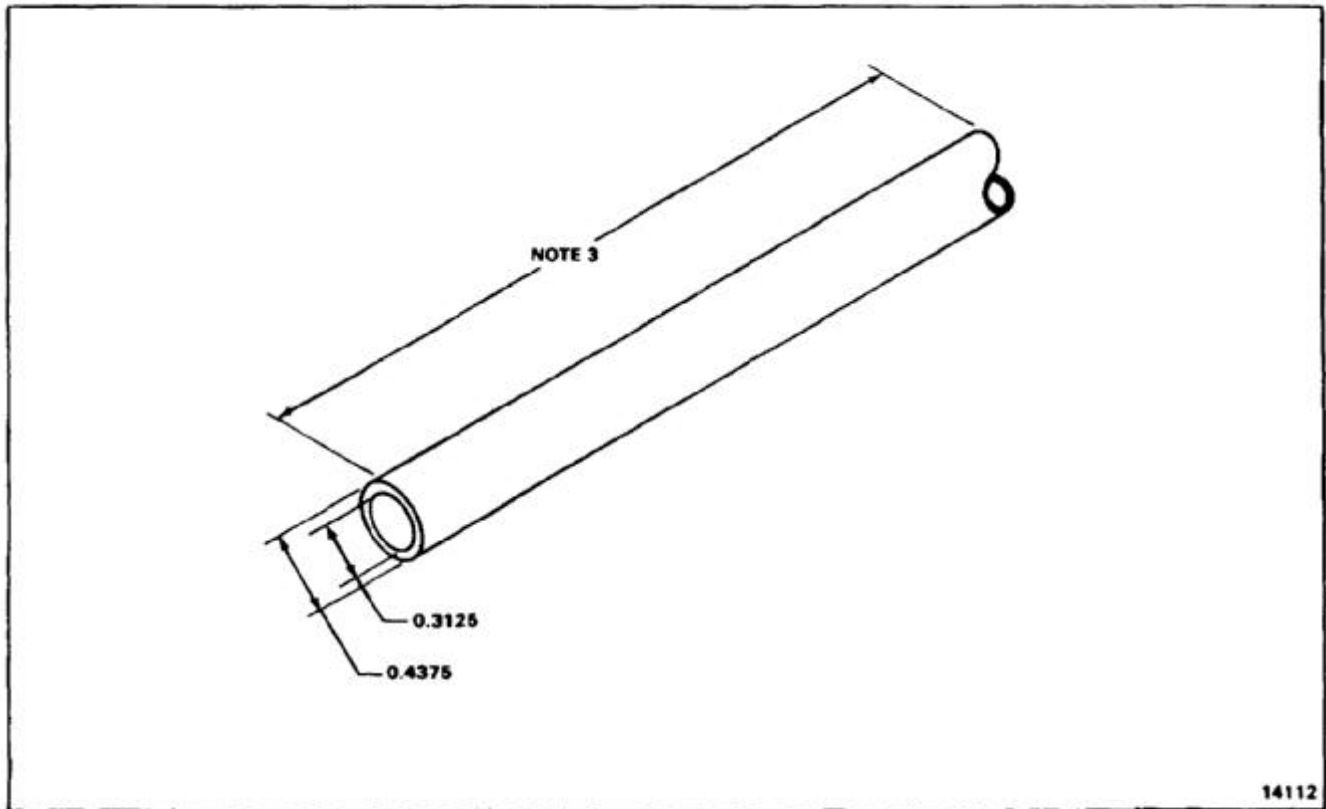

END OF TASK

NOTES:

1. FABRICATE FROM 321 CRES ROUND SEAMLESS TUBING MIL-T-8606 TYPE I COND. A.
2. ALL DIMENSIONS IN INCHES.
3. STOCK SIZE 0.148 DIA X 0.015 WALL THICKNESS X 104 LENGTH.
4. LENGTH OF REPLACEMENT IS SAME AS ORIGINAL PART.

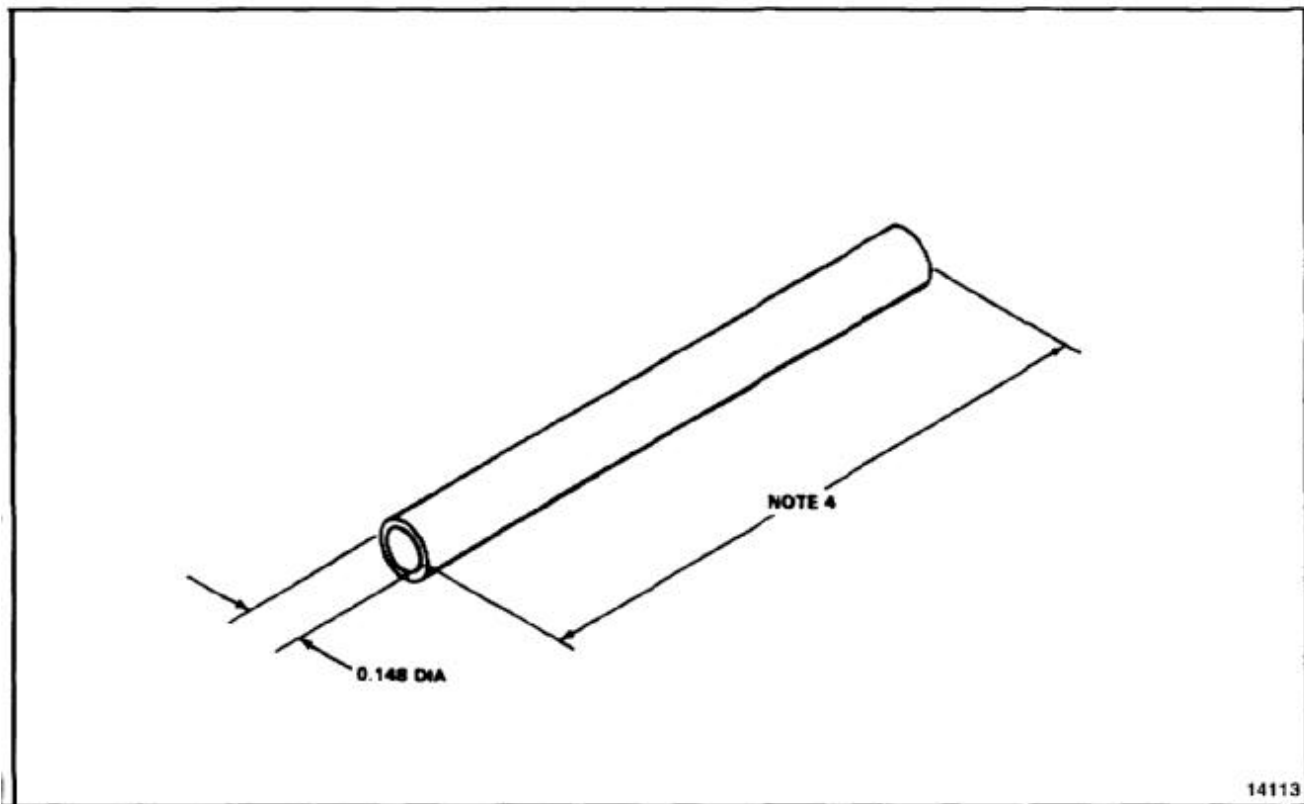

END OF TASK

NOTES:

1. FABRICATE FROM NYLON WEB 0.030 X 1.0 X 8.6, MIL-W-4088 TYPE II.
2. ALL DIMENSIONS IN INCHES.
3. SEAR END TO PREVENT FRAYING.
4. THIS RADIUS IS OPTIONAL.

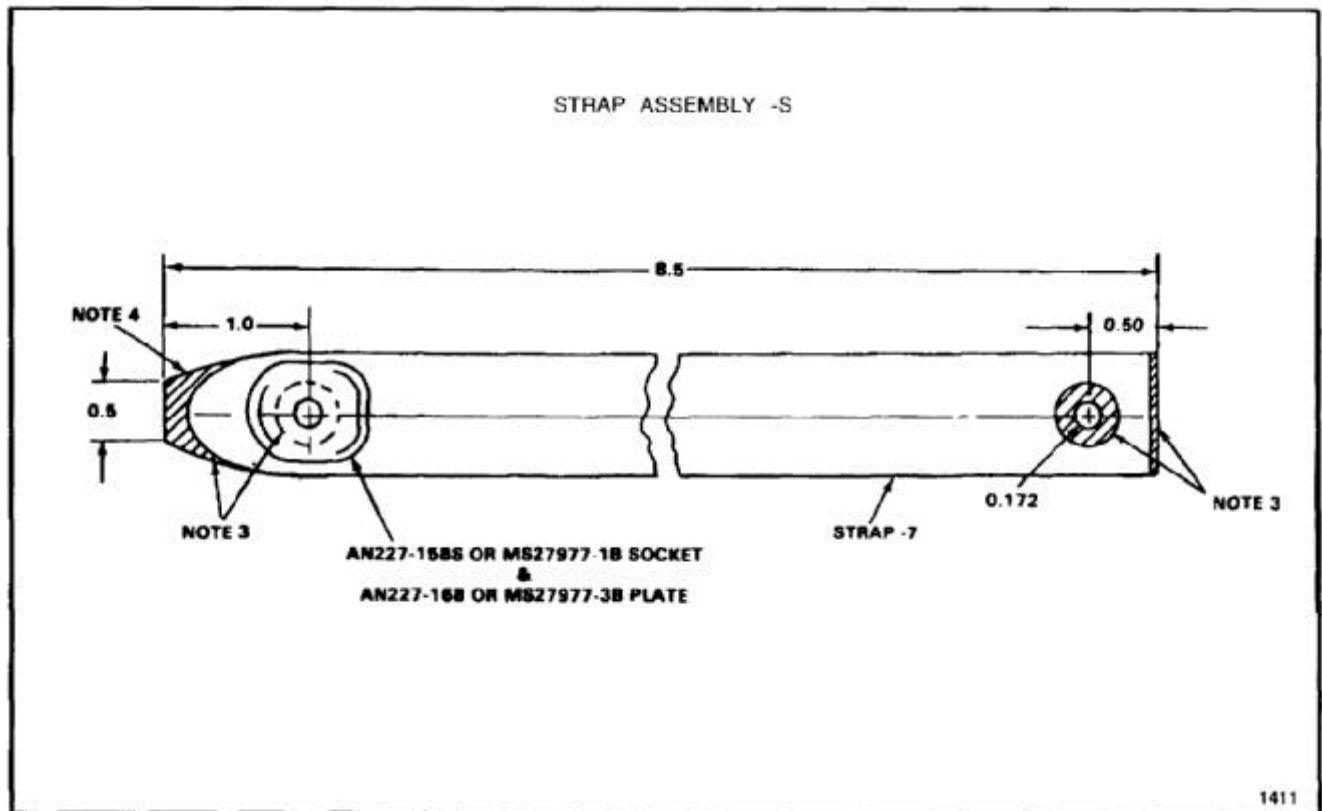

END OF TASK

NOTES:

1. FABRICATE FROM 1 X 19 CRES STEEL CABLE MIL-C-5424.
2. ALL DIMENSIONS IN INCHES.
3. STOCK SIZE 0.0625 X 8.
4. LENGTH OF REPLACEMENT IS SAME AS ORIGINAL.
5. SWAGE SLEEVE 18-1-C IN ACCORDANCE WITH SPEC MIL-T-6117.

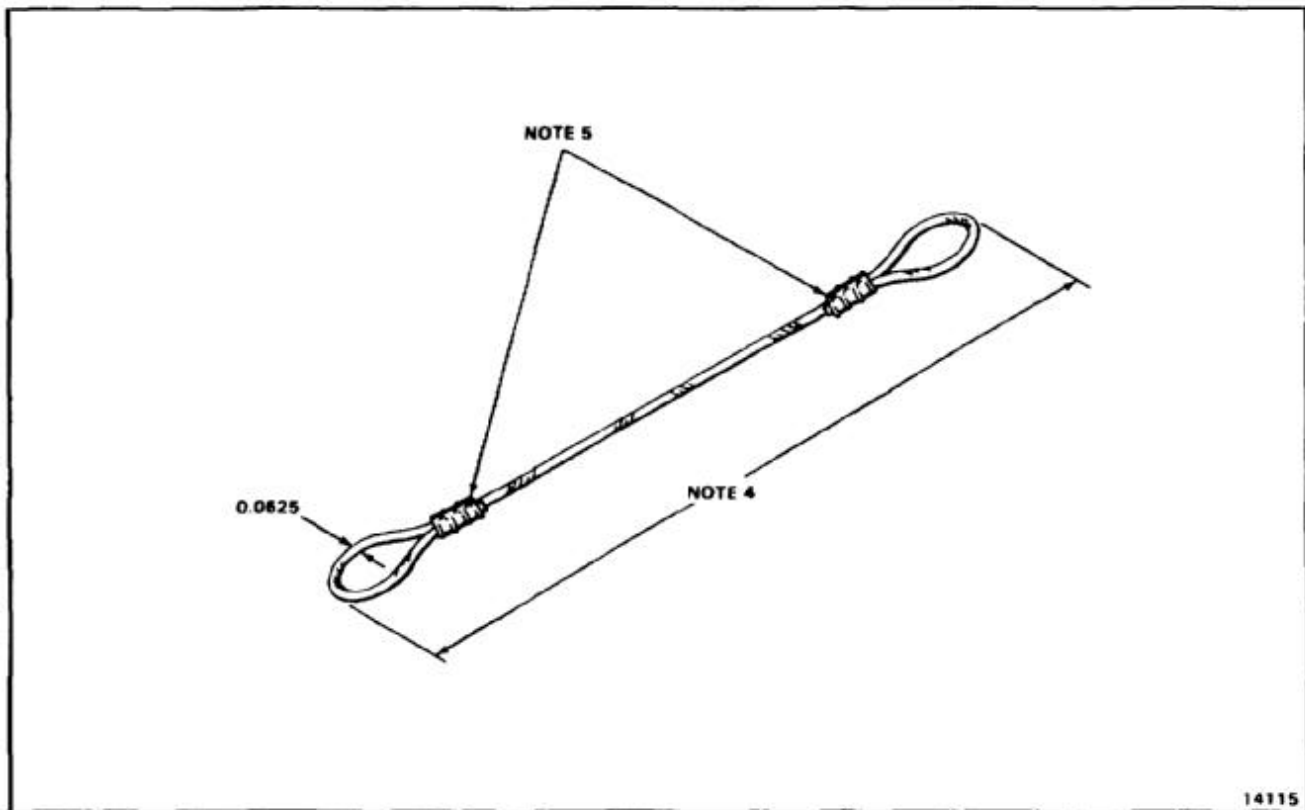

END OF TASK

NOTES:

1. FABRICATE FROM NYLON ROPE MIL-R-17343
0.1875 DIAMETER X 50 LENGTH.
2. ALL DIMENSIONS IN INCHES.
3. SEAR END OF ROPE.
4. CRIMP TUBE 145E4019-29 ON ROPE.
5. REFER TO E-67.

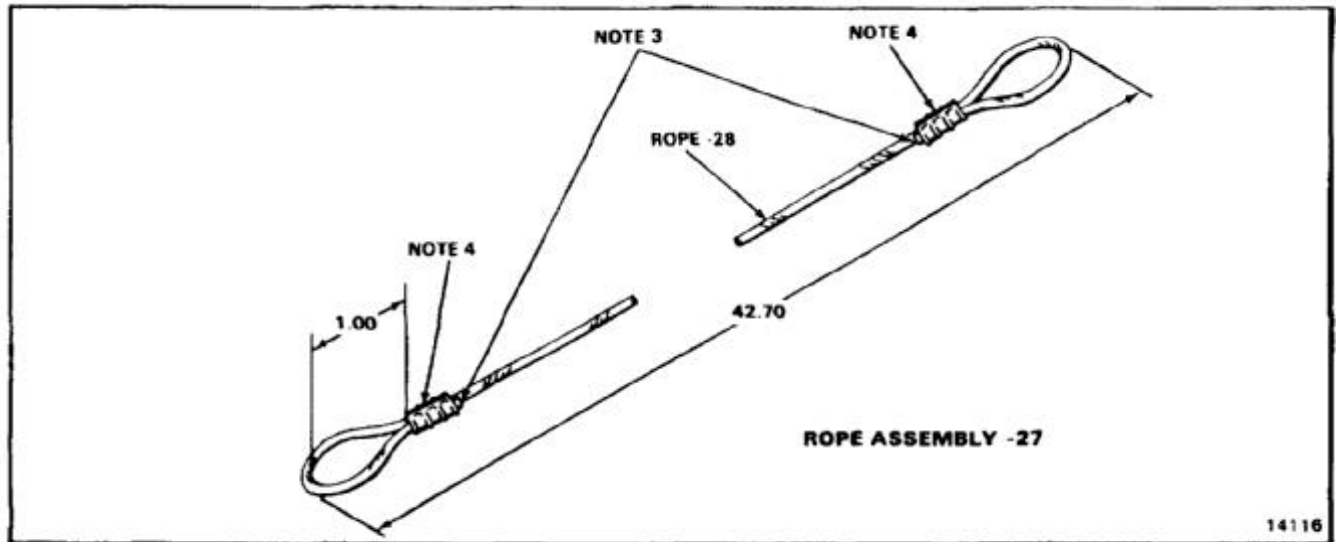

END OF TASK

NOTES:

1. FABRICATE FROM ALUMINUM ALLOY TUBE
6061-0 MIL-T-7081.
2. STOCK SIZE 0.035 WALL THICKNESS X 0.375
DIA X 0.50 LENGTH.
3. ALL DIMENSIONS IN INCHES.
4. REFER TO E-66.
5. REFER TO E-68.

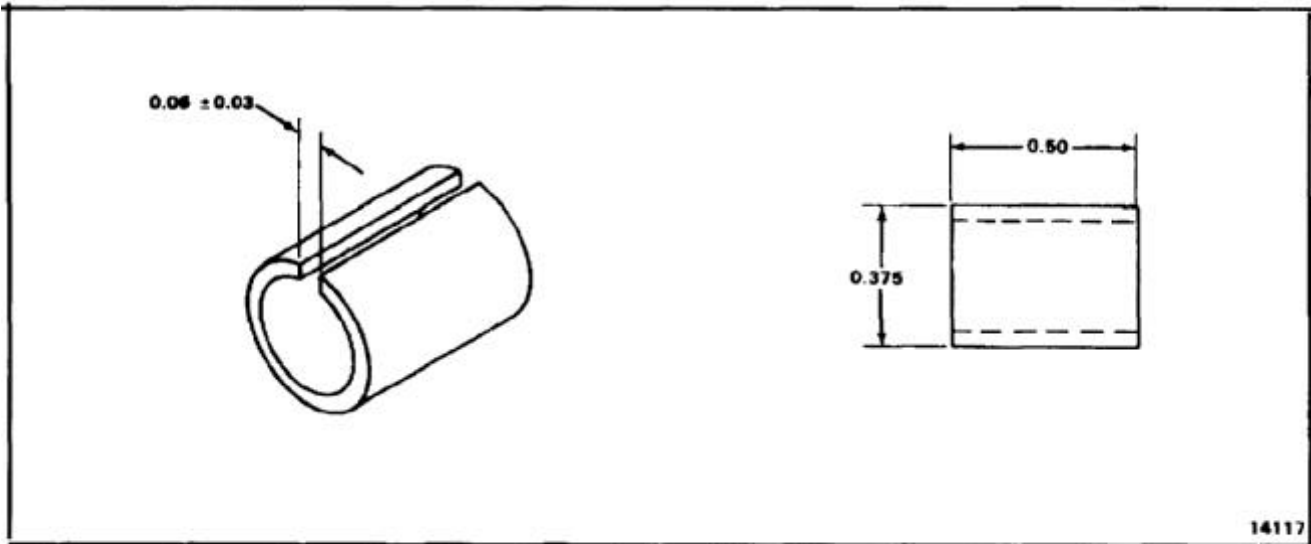

END OF TASK

NOTES:

1. FABRICATE FROM NYLON ROPE MIL-R-17343
0.1875 DIAMETER X 52 LENGTH.
2. ALL DIMENSIONS IN INCHES.
3. SEAR ENDS OF ROPE.
4. CRIMP TUBE 145E4019-29 ON ROPE. APPLY
REQUIRED PRESSURE TO RETAIN LOOP
UNDER LIGHT LOAD.
5. REFER TO E-67.

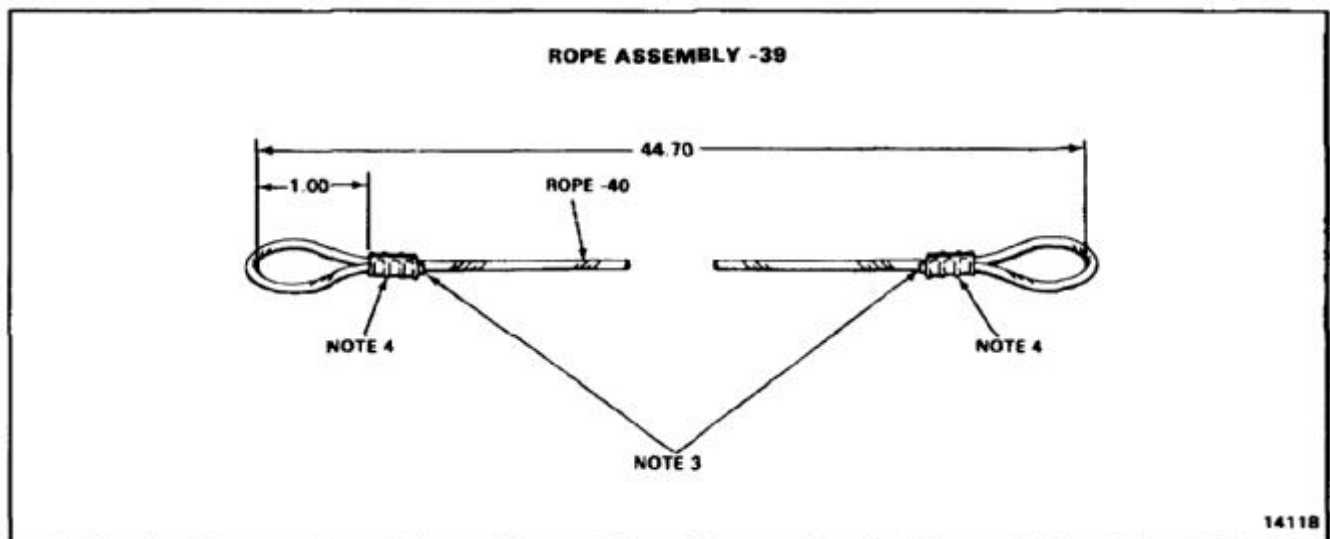

END OF TASK

NOTES:

1. FABRICATE CRES STEEL FLEX PREF WIRE ROPE MIL-W-83420.
2. STOCK SIZE 0.125 X 7 X 19 X 8.
3. SWAGE M520664C4 BALL END IN ACCORDANCE WITH SPEC MIL-T-6117.
4. ALL DIMENSIONS IN INCHES.
5. 145E5507-3 WELD HANDLE ASSEMBLY.

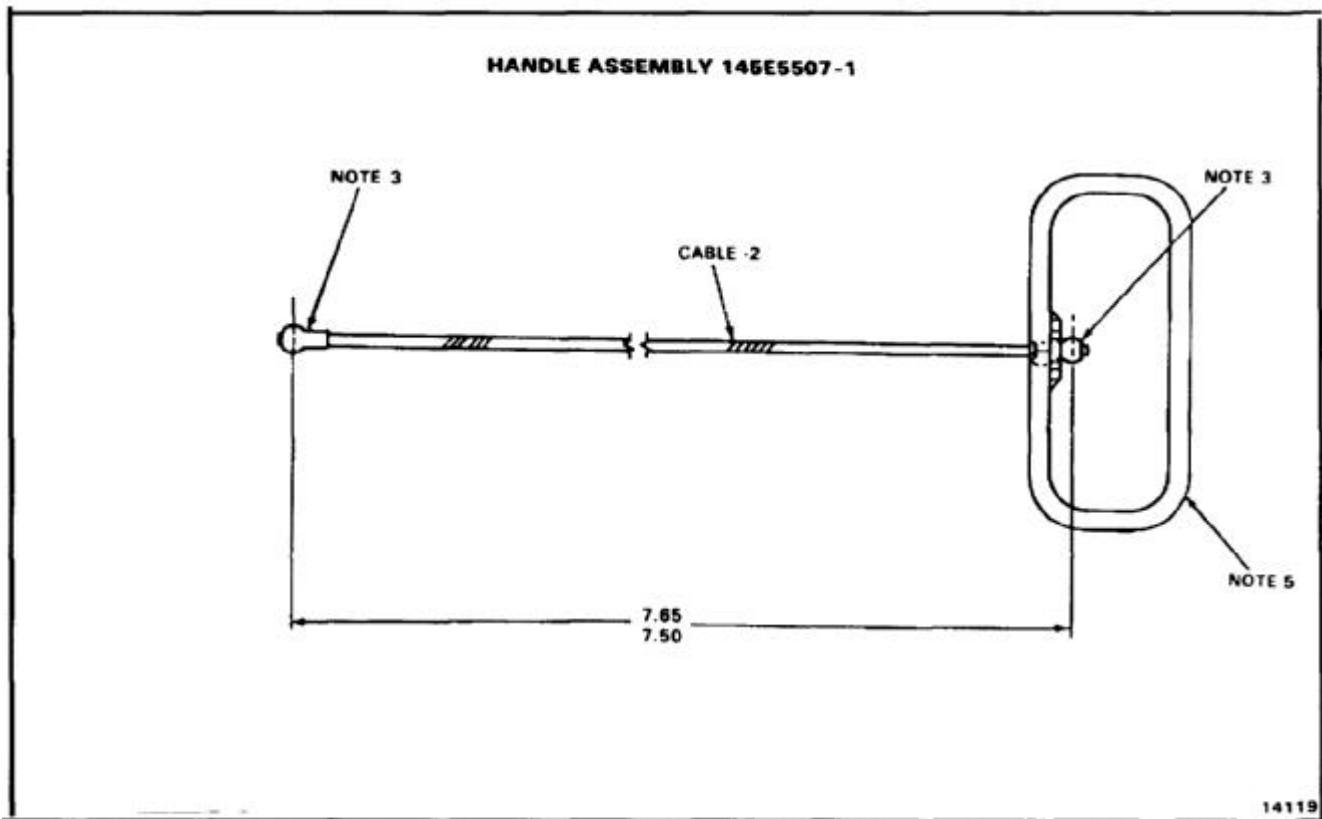

END OF TASK

E-70 EMERGENCY RELEASE CABLE 114E5090-13**E-70****NOTES:**

1. FABRICATE FROM CRES STEEL FLEX PREF MIL-C-5424.
2. STOCK SIZE 0.125 DIAMETER X 7 X 19 X 13 LENGTH.
3. LENGTH OF REPLACEMENT CABLE IS SAME AS ORIGINAL.
4. SWAGE AN664C-4 BALL END IN ACCORDANCE WITH SPEC MIL-T-6117.
5. ALL DIMENSIONS IN INCHES.

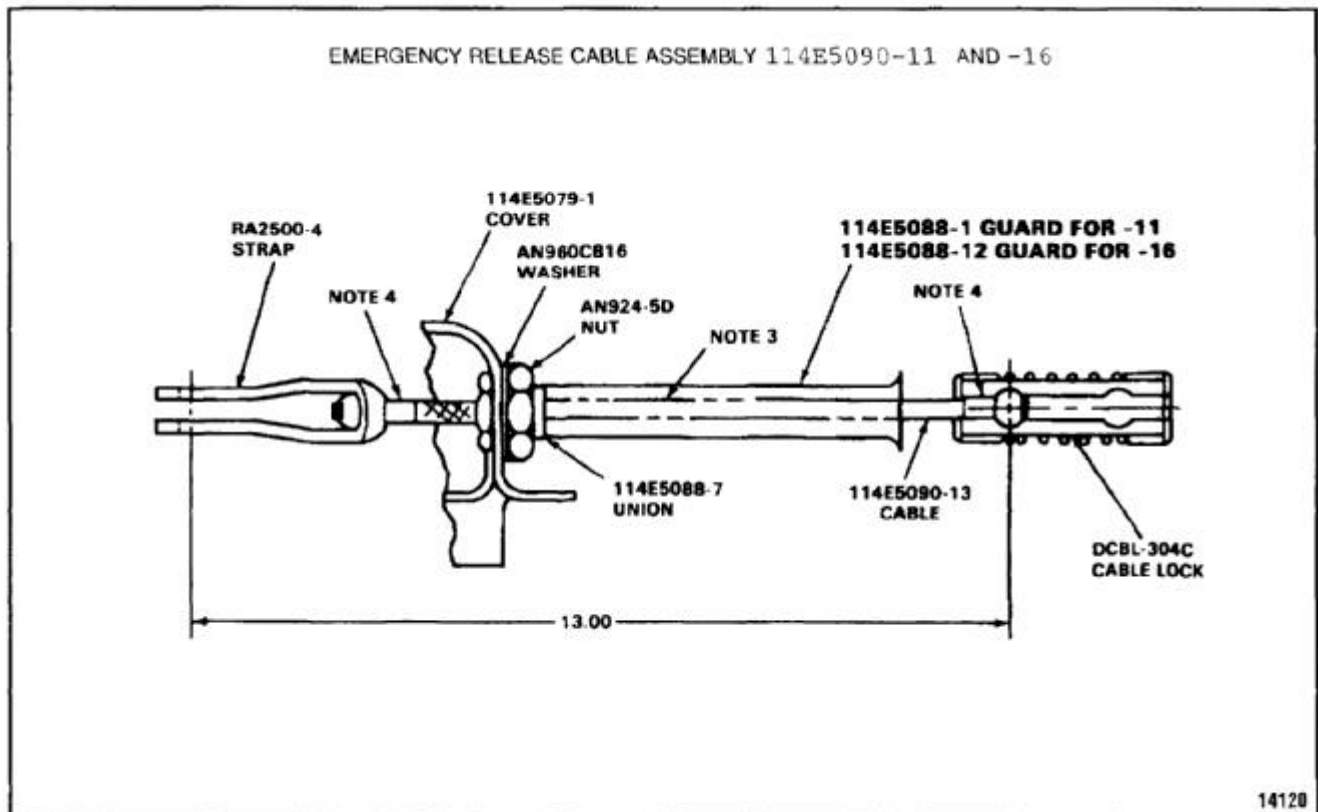

END OF TASK

NOTES:

1. FABRICATE FROM NSN 4720-00-923-0399.
2. ALL DIMENSIONS IN INCHES.
3. SIZE 0.25 OD X 0.21875 ID X 46 LENGTH
STRAIGHT FITTING END
°(NSN 4730-00-948-9314) TO ELBOW 90°
FLARELESS (NSN 4730-00-949-1656).
4. 0.660 MINIMUM 0.956 MAXIMUM REACH.

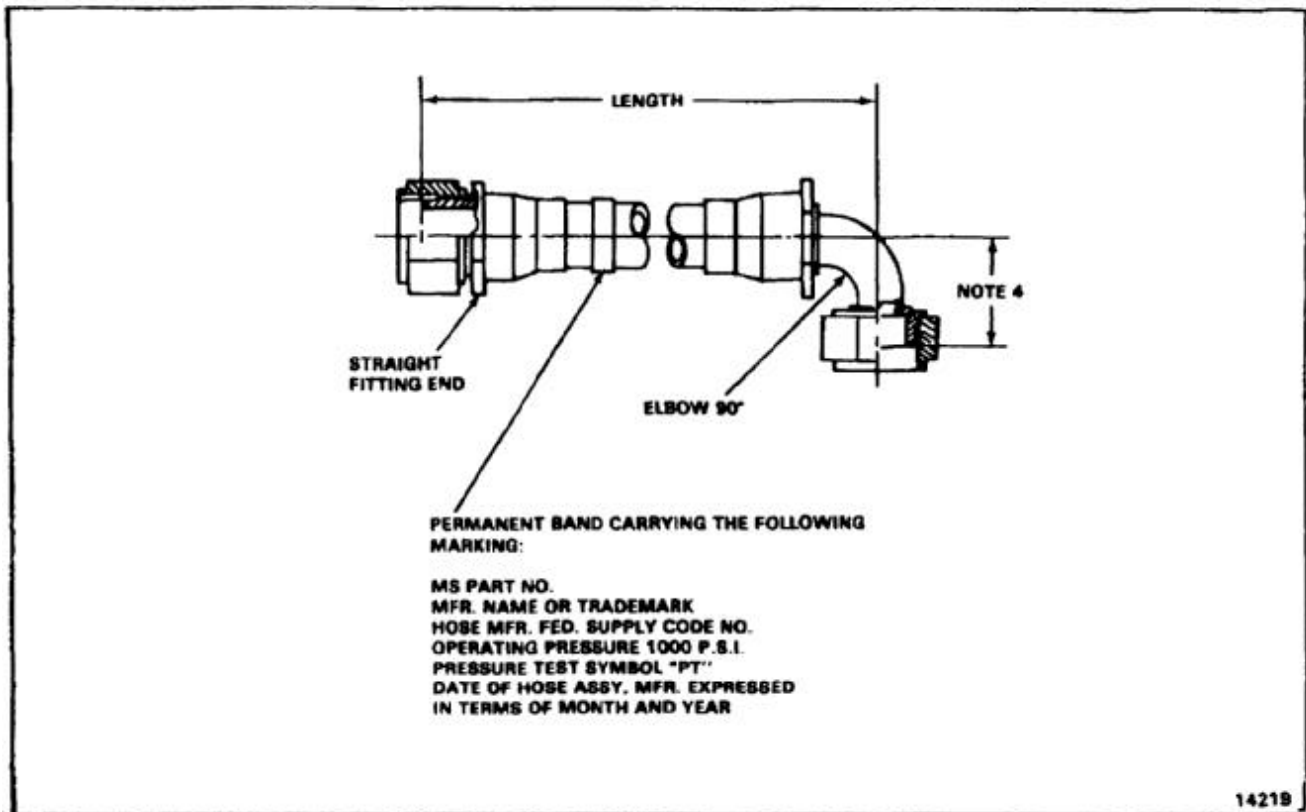

END OF TASK

NOTES:

1. FABRICATE FROM 7075-T6 SEAMLESS ALUMINUM ALLOY TUBE.
2. ALL DIMENSIONS IN INCHES.
3. STOCK SIZE 1.125 OD X 0.125 WALL THICKNESS X 3.0 LENGTH.

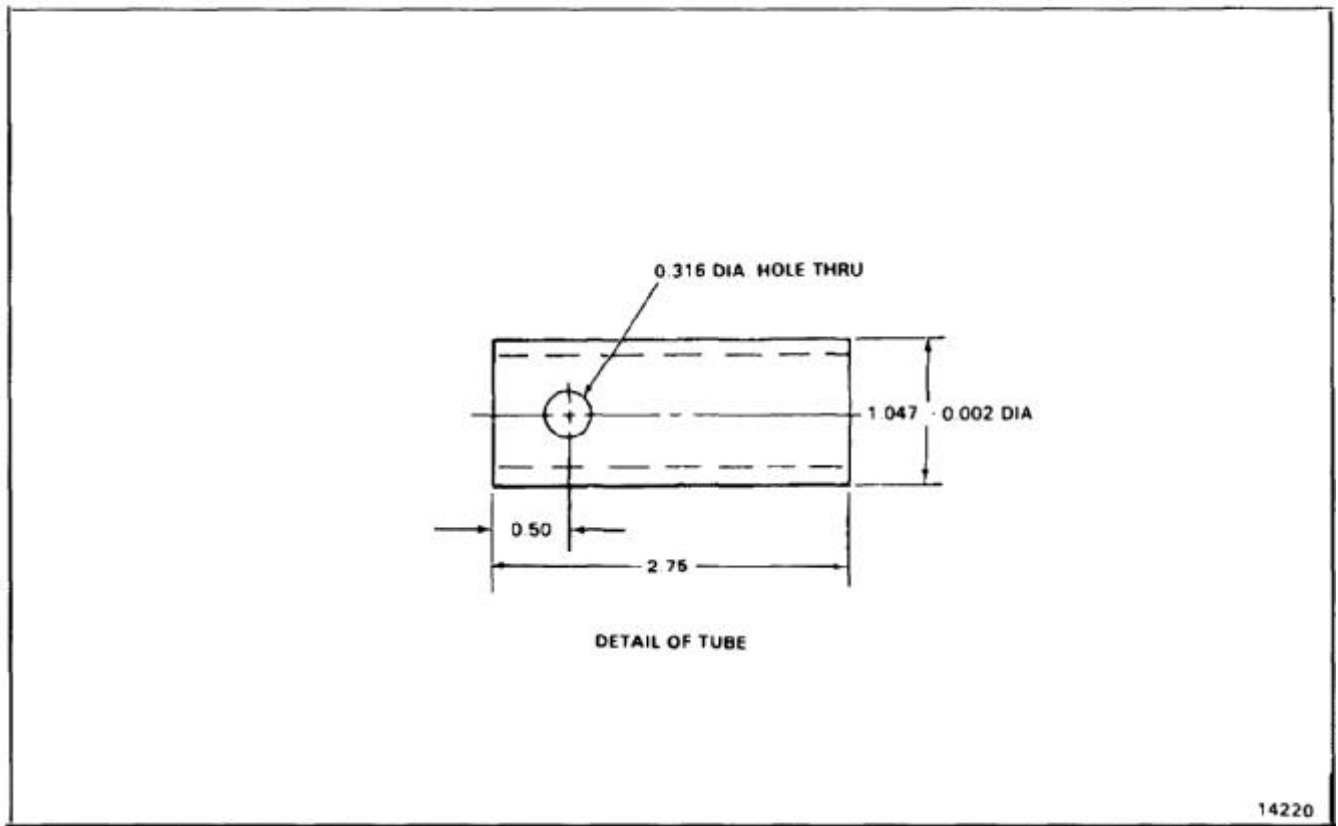

END OF TASK

NOTES:

1. FABRICATE FROM 7075-T6 SEAMLESS ALUMINUM ALLOY TUBE.
2. ALL DIMENSIONS IN INCHES.
3. STOCK SIZE 1.125 OD X 0.095 WALL THICKNESS X 3.0 LENGTH.
4. FINISH AS REQUIRED.

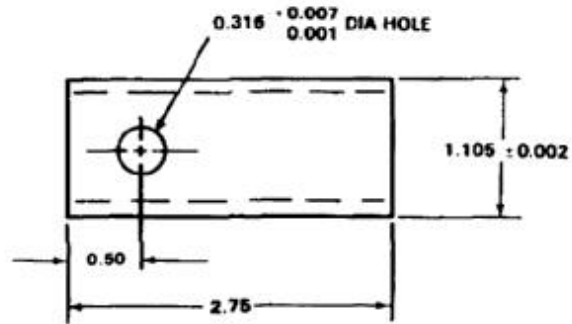

14221

END OF TASK

E-150

NOTES:

1. BLANKET STOCK SIZE IS 20.0 X 20.0.
2. ALL DIMENSIONS IN INCHES.
3. TRIM CLOTH IS IMPERVIOUS FILM OF VINYL COPOLYMER 0.0015 THICK. REFER TO MIL-P-6264.
4. BLANKET INTERIOR IS THREE LAYERS 0.5 THICK GLASS WOOL BATTS TYPE 1. REFER TO MIL-B-5924.
5. THREAD TO SPECIFICATIONS OF MIL-T-7807. THREAD IS NYLON TYPE 1, CLASS 2, SIZE B.
6. USE OLD BLANKET FOR TEMPLATE.

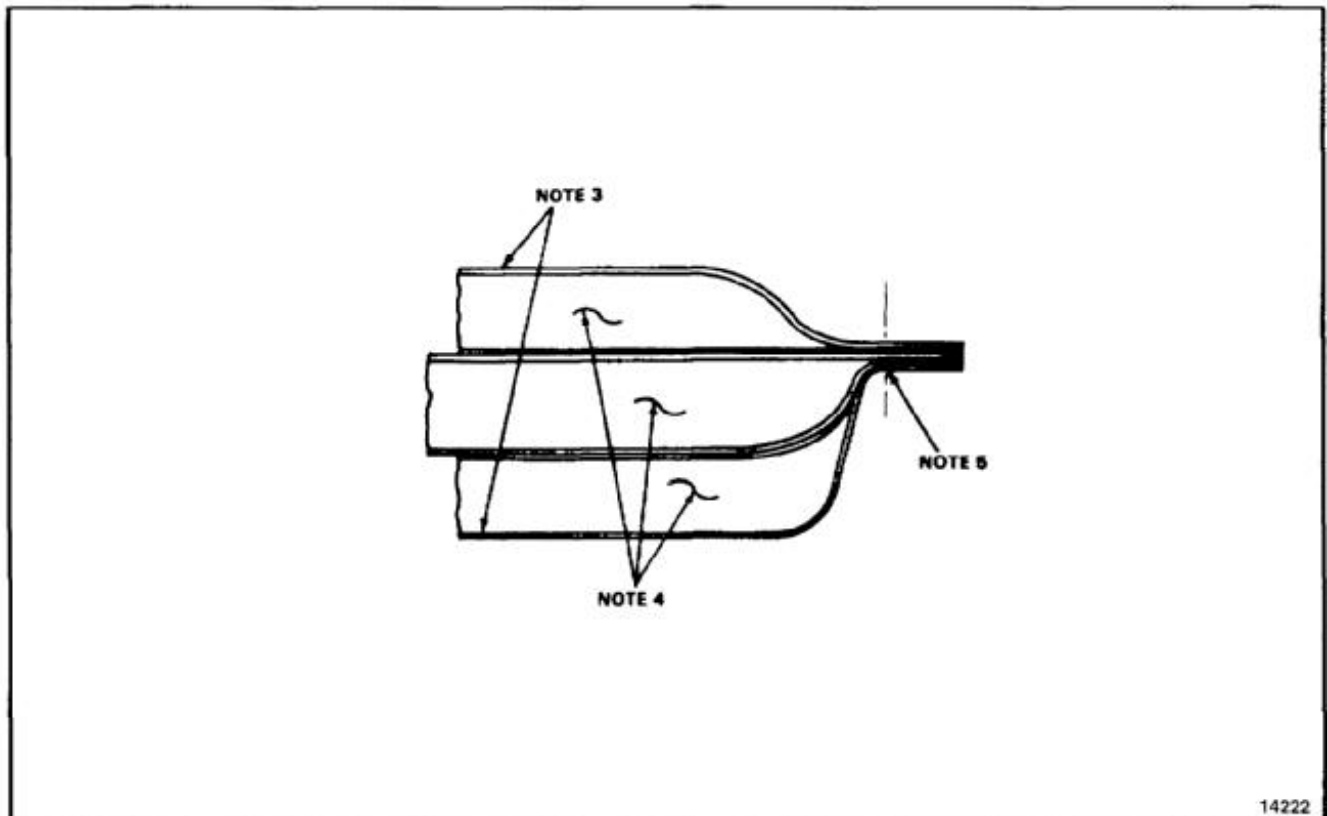

14222

END OF TASK

NOTES:

1. FABRICATE FROM ALUMINUM ALLOY CLAD SHEET 2024-T3 PER QQ-A-250/5.
2. ALL DIMENSIONS IN INCHES.
3. BRACKET STOCK SIZE 0.040 X 2.1 X 5.7.
4. FINISH AS REQUIRED.
5. 114E4153-4 IS OPPOSITE TO -3.

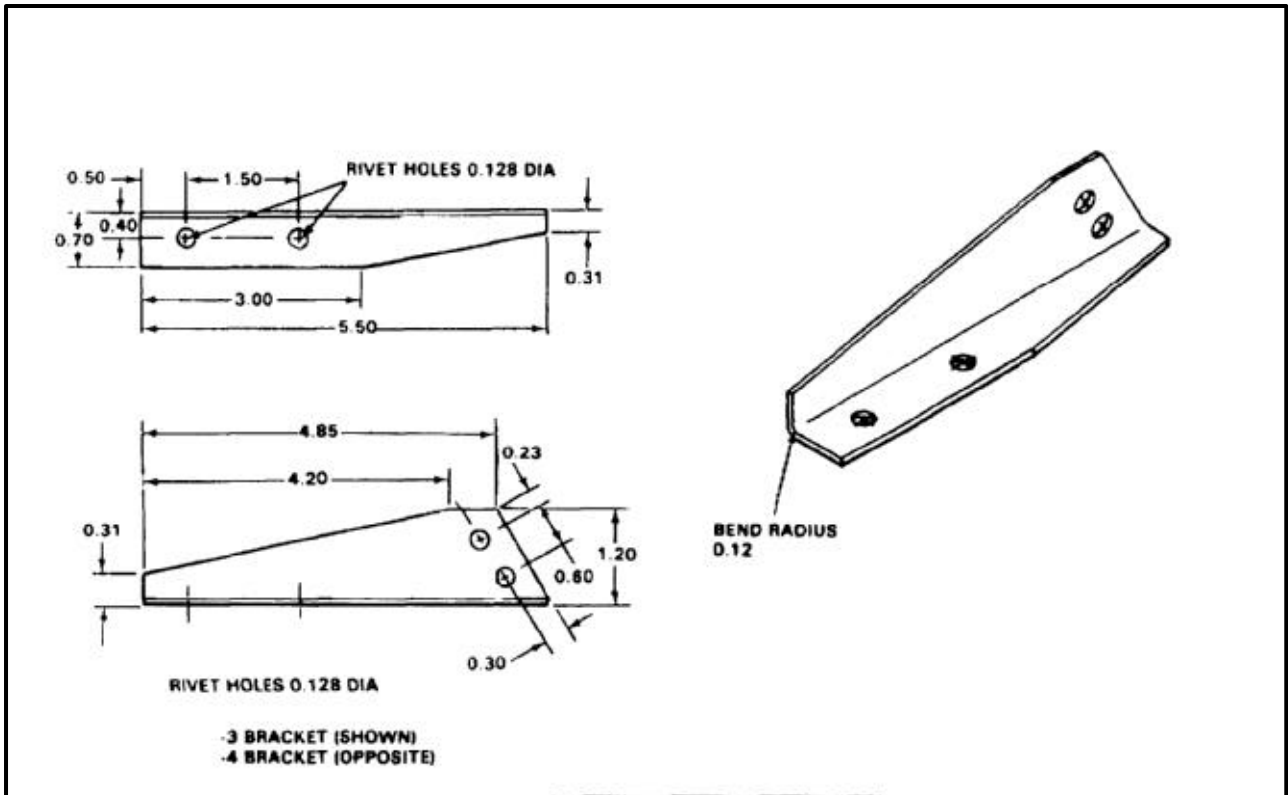

END OF TASK

NOTES:

1. BLANKET STOCK SIZE IS 23.0 X 28.5.
2. ALL DIMENSIONS IN INCHES.
3. TRIM CLOTH IS IMPERVIOUS FILM OF VINYL COPOLYMER 0.0015 THICK, TYPE 1. REFER TO MIL-P-6264. BMC 6-8-7A.
4. BLANKET INTERIOR IS THREE LAYERS 0.5 THICK GLASS WOOL BATTS TYPE 1. REFER TO MIL-L-5924.
5. THREAD TO SPECIFICATIONS OF MIL-T-7807. THREAD IS NYLON TYPE 1, CLASS 2, SIZE B.

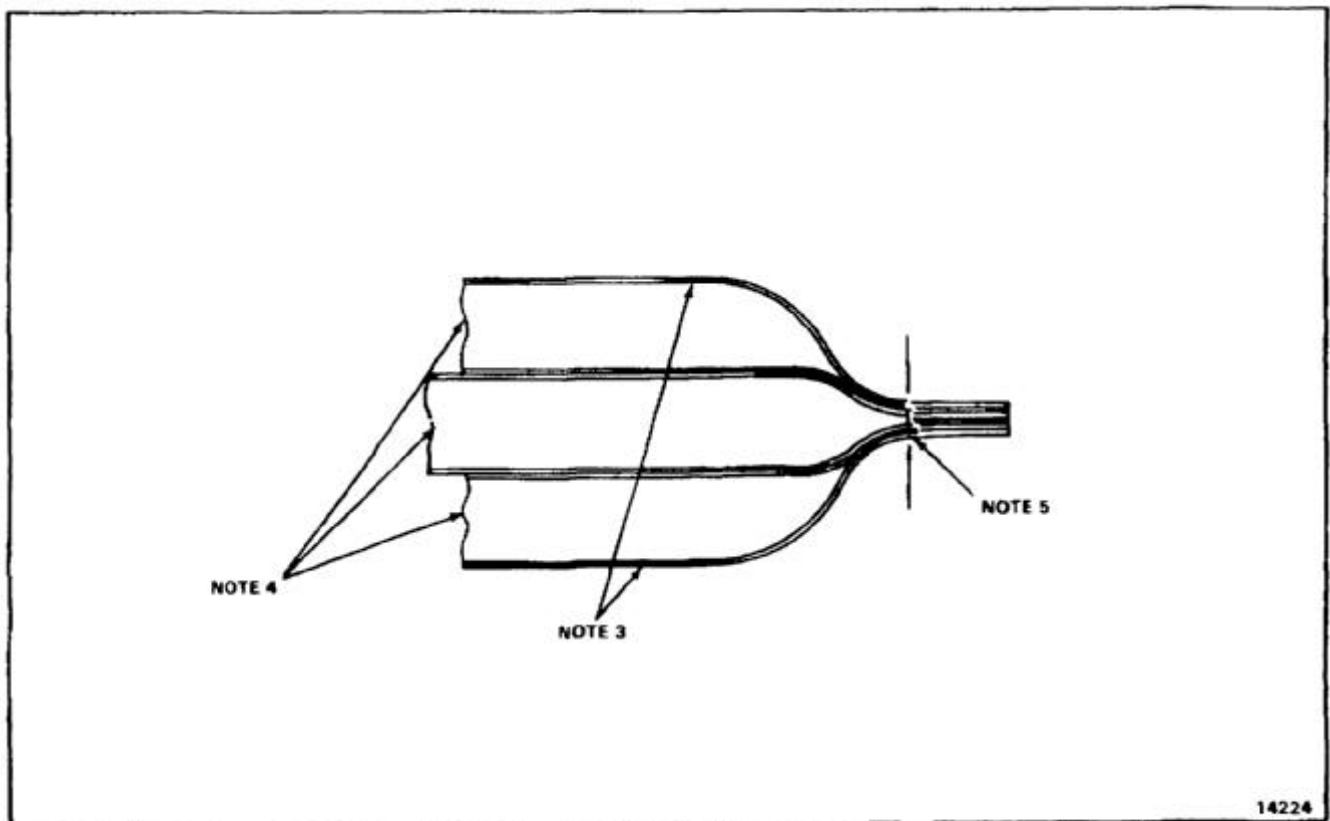

END OF TASK

NOTES:

1. FABRICATE FROM ALUMINUM ALLOY 7075-T6511 EXTRUSION.
2. ALL DIMENSIONS IN INCHES.
3. STOCK SIZE AND 10134-1005 X 1.6.
4. FINISH WITH YELLOW ZINC CHROMATE PRIMER (E-290).

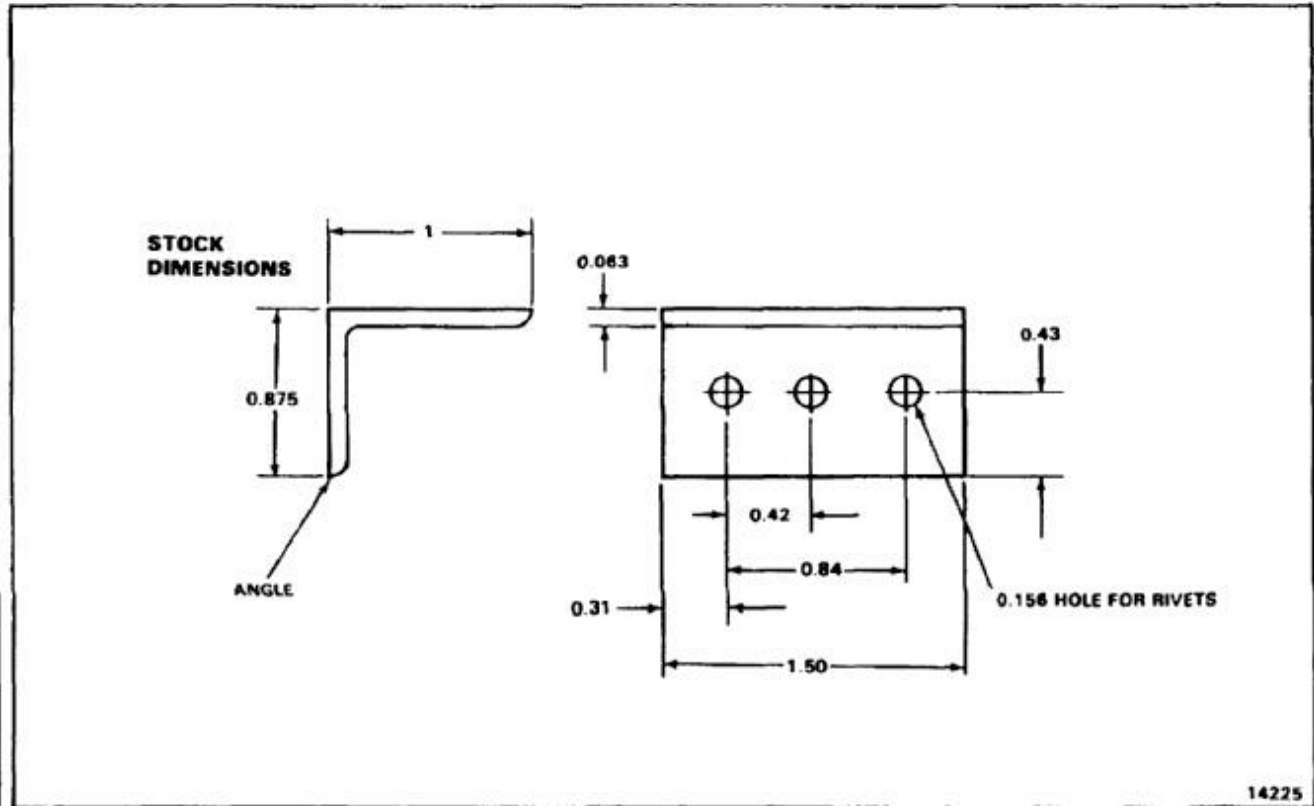

END OF TASK

NOTES:

1. FABRICATE FROM SYNTHETIC RUBBER SHEET MIL-R-6855 CL II GR40.
2. ALL DIMENSIONS IN INCHES.
3. STOCK SIZE 0.060 X 1.0 X 1.0.

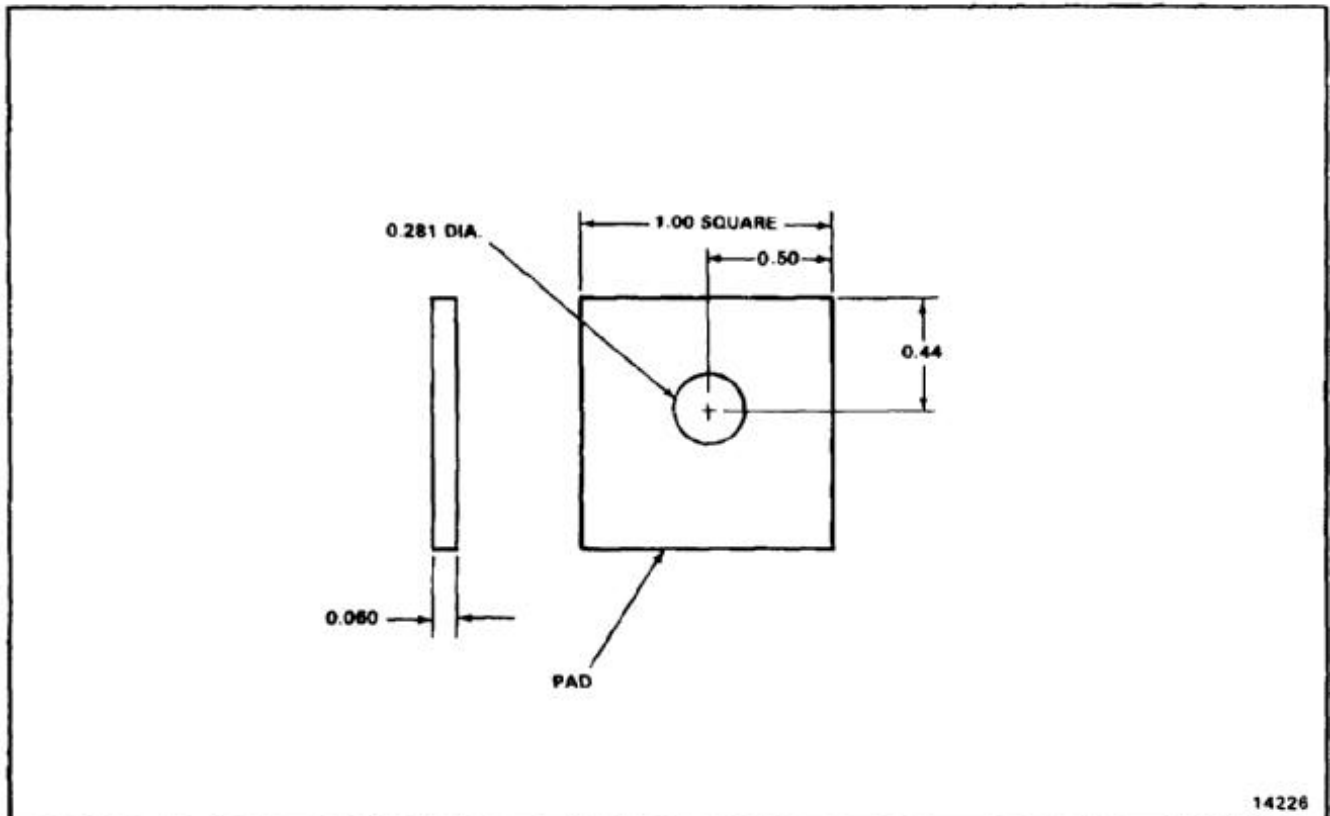

END OF TASK

NOTES:

1. FABRICATE FROM ALUMINUM ALLOY 7075-T6511 EXTRUSION.
2. ALL DIMENSIONS IN INCHES.
3. STOCK SIZE AND 10134-2001 X 1.6.
4. FINISH WITH YELLOW ZINC CHROMATE PRIMER (E-290).

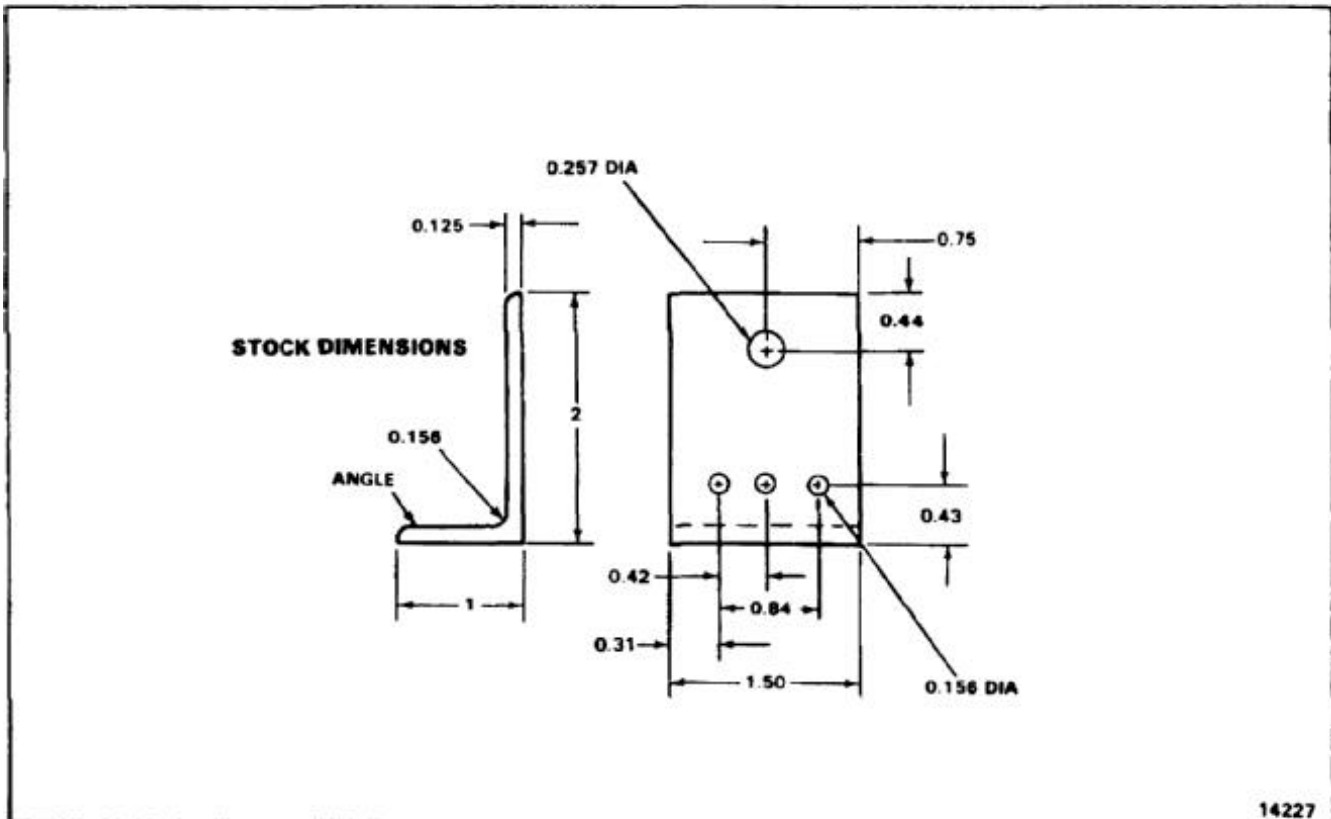

END OF TASK

NOTES:

1. FABRICATE FROM ALUMINUM ALLOY 7075-T6511 EXTRUSION.
2. ALL DIMENSIONS IN INCHES.
3. STOCK SIZE AND 10134-2001 X 1.6.
4. FINISH WITH YELLOW ZINC CHROMATE PRIMER (E-290).

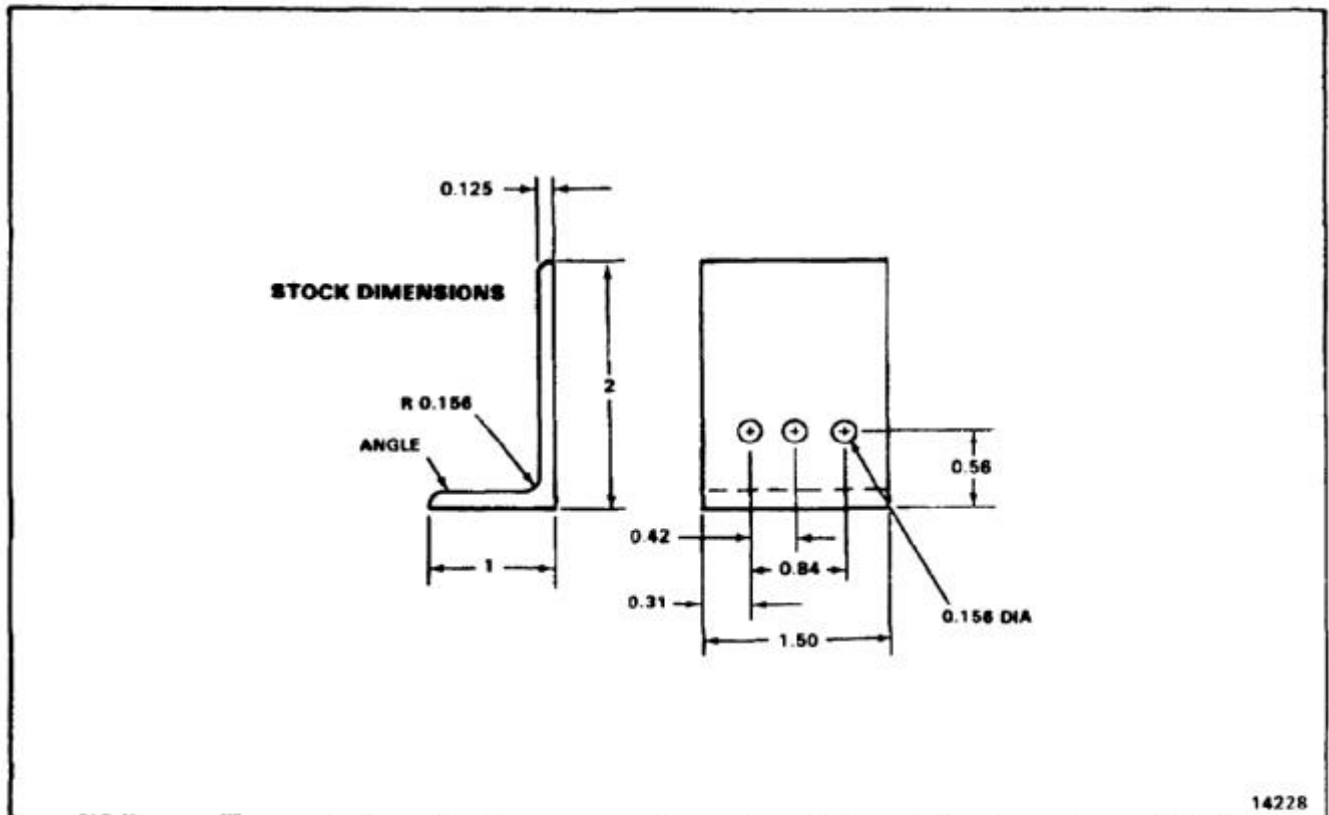

END OF TASK

NOTES:

1. FABRICATE FROM ALUMINUM ALLOY SHEET CLAD 7075-T6.
2. STOCK SIZE 0.063 X 1.2 X 7.0.
3. ALL DIMENSIONS IN INCHES.
4. USE OLD CLIP FOR TEMPLATE TO LOCATE RIVET HOLES IN REPLACEMENT.
5. FINISH WITH YELLOW ZINC CHROMATE PRIMER (E-290).

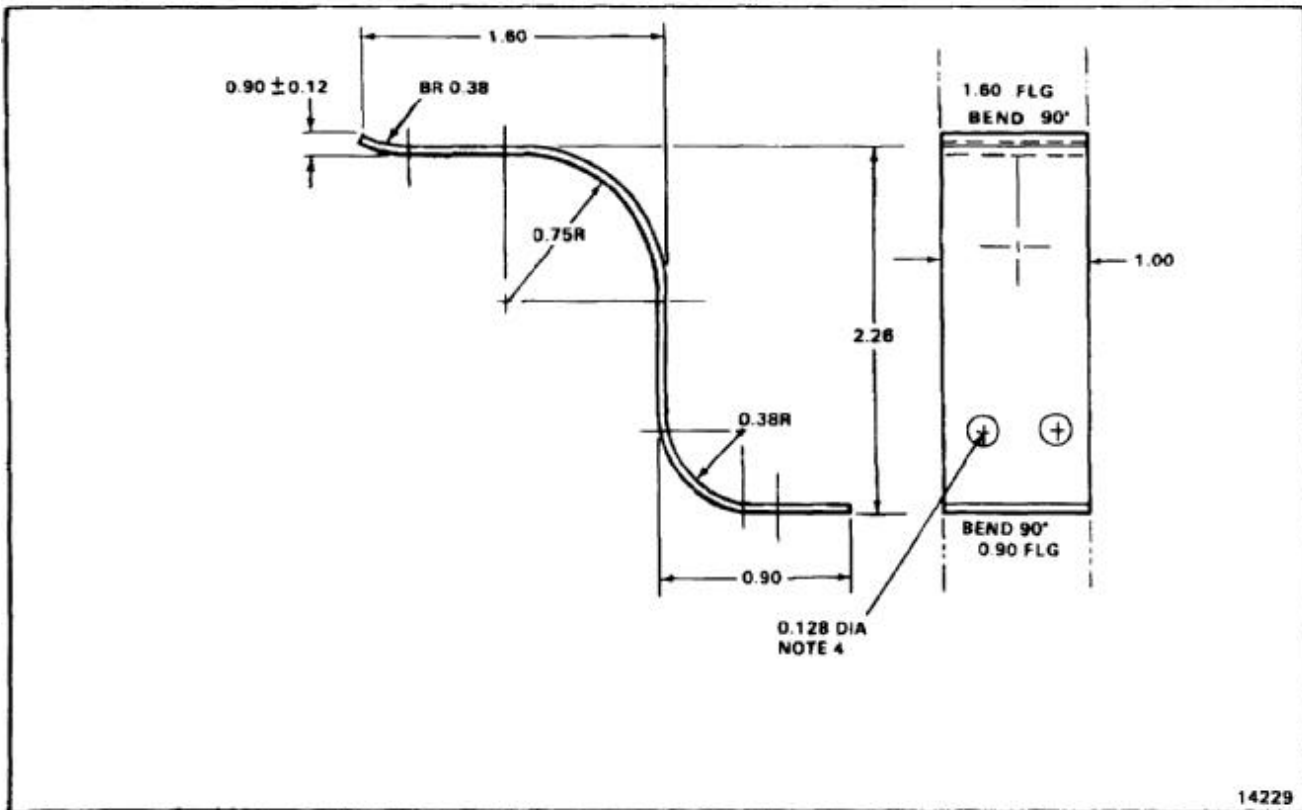

END OF TASK

NOTES:

1. FABRICATE FROM ALUMINUM ALLOY SHEET CLAD 2024-T3.
2. STOCK SIZE 0.040 X 0.8 X 4.7.
3. ALL DIMENSIONS IN INCHES.
4. USE OLD CLIP FOR TEMPLATE TO LOCATE RIVET HOLES IN REPLACEMENT.
5. LENGTH OF REPLACEMENT IS SAME AS ORIGINAL.
6. FINISH WITH YELLOW ZINC CHROMATE PRIMER (E-290).

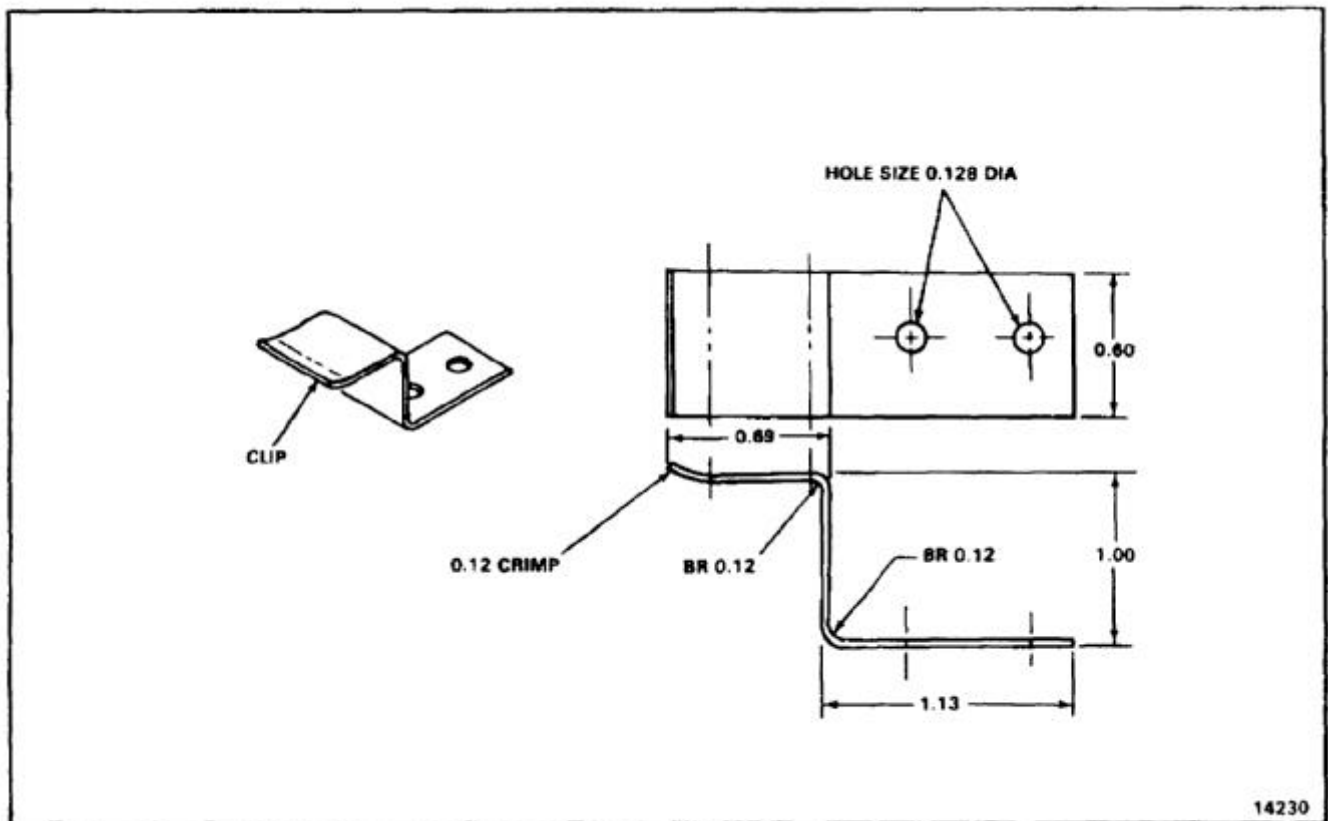

END OF TASK

NOTES:

1. FABRICATE FROM ALUMINUM ALLOY SHEET CLAD 2024-T3.
2. STOCK SIZE 0.063 X 0.6 X 3.2.
3. ALL DIMENSIONS IN INCHES.
4. USE OLD STRAP FOR TEMPLATE TO LOCATE RIVET HOLES IN REPLACEMENT.
5. MAKE REPLACEMENT STRAP SAME LENGTH AS ORIGINAL.
6. FINISH WITH YELLOW ZINC CHROMATE PRIMER (E-290).

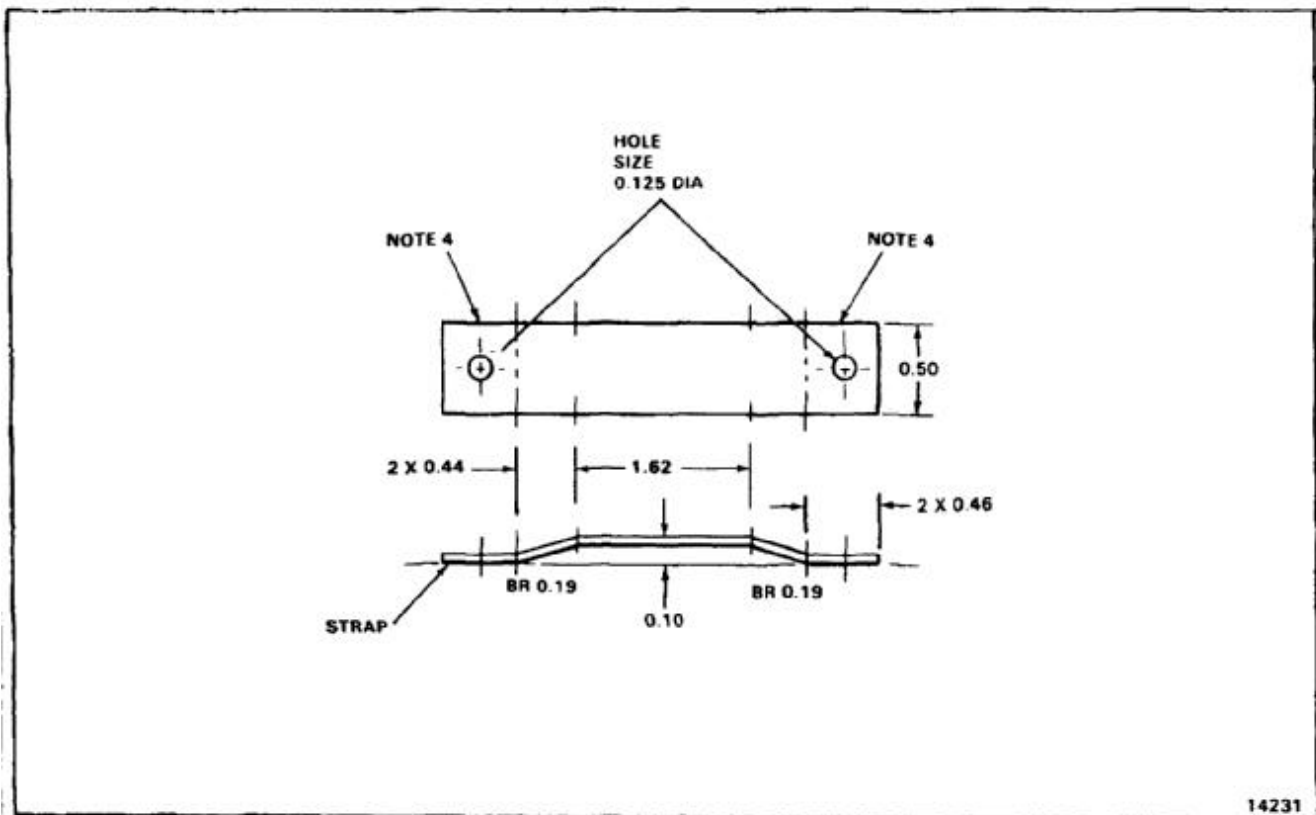

END OF TASK

NOTES:

1. FABRICATE FROM CRES CABLE MIL-C-5424.
2. STOCK SIZE 0.0625 DIA X 6.0.
3. ALL DIMENSIONS IN INCHES.
4. REPLACEMENT CABLE IS SAME LENGTH AS ORIGINAL.
5. SWAGE SLEEVE 18-1-C IN ACCORDANCE WITH SPEC MIL-T-6117.

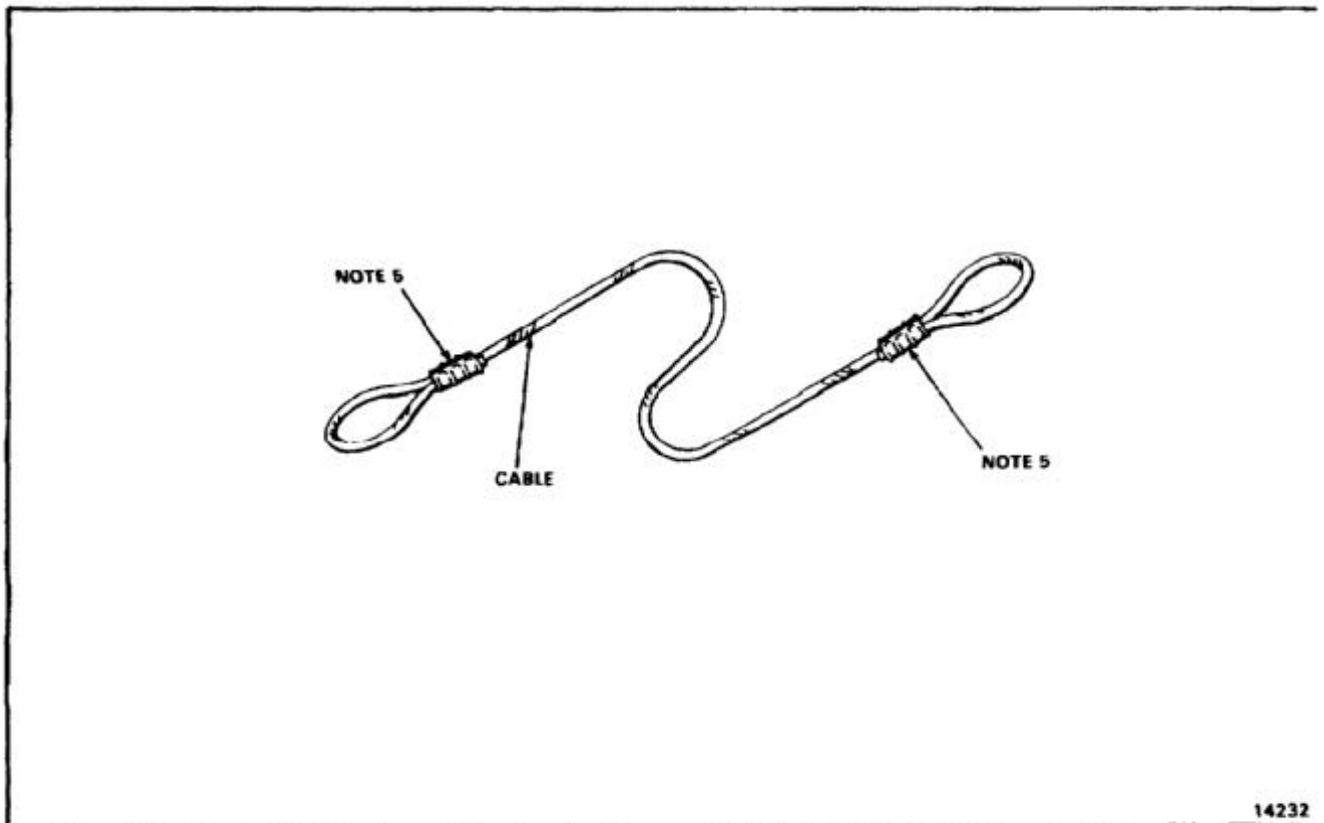

14232

END OF TASK

NOTES:

1. FABRICATE FROM CONVOLUTED NONMETALLIC TEFLON NSN 4720-01-130-8532.
2. ALL DIMENSIONS IN INCHES.
3. SHAPE HOSE TO THE CONFIGURATION OF ORIGINAL.

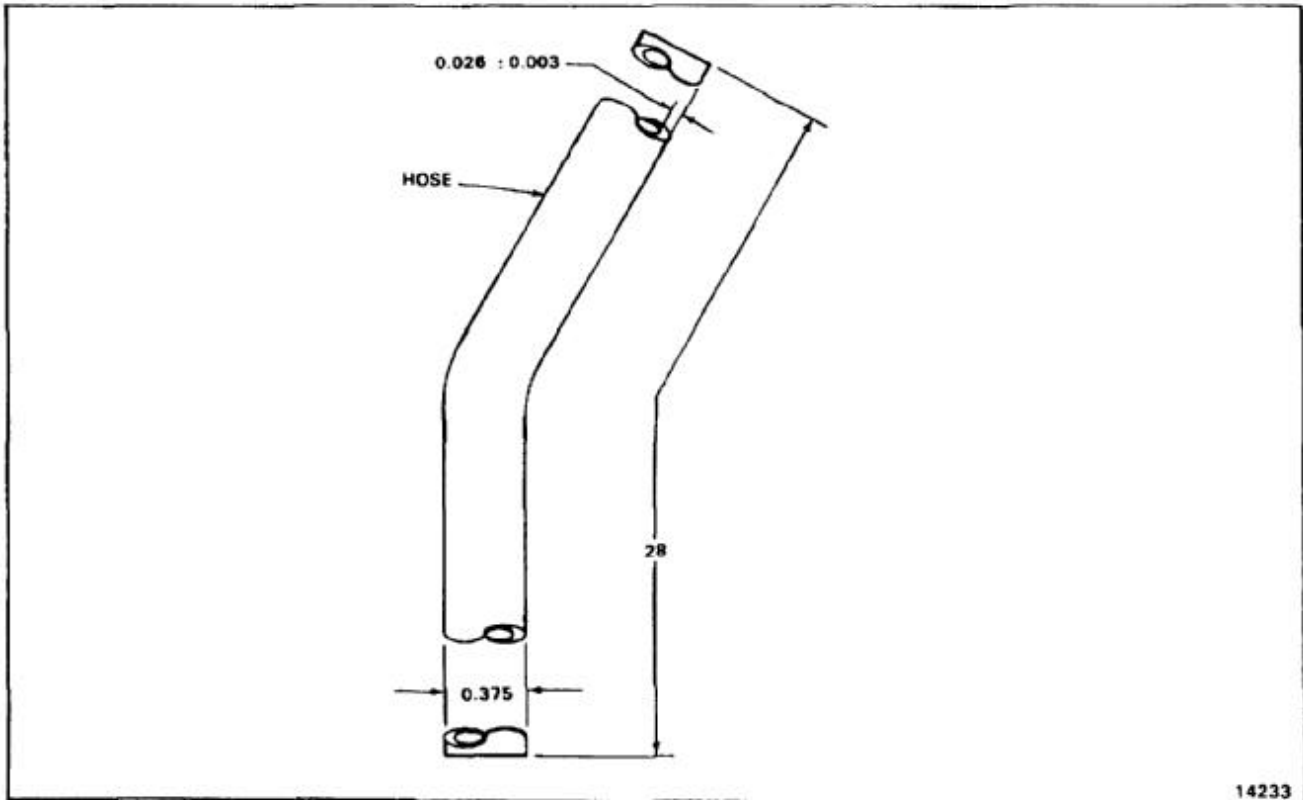

14233

END OF TASK

E-162

NOTES:

1. FABRICATE FROM CONVOLUTED NONMETALLIC TEFLON NSN 4720-01-130-8532.
2. ALL DIMENSIONS IN INCHES.
3. SHAPE HOSE TO THE CONFIGURATION OF ORIGINAL.

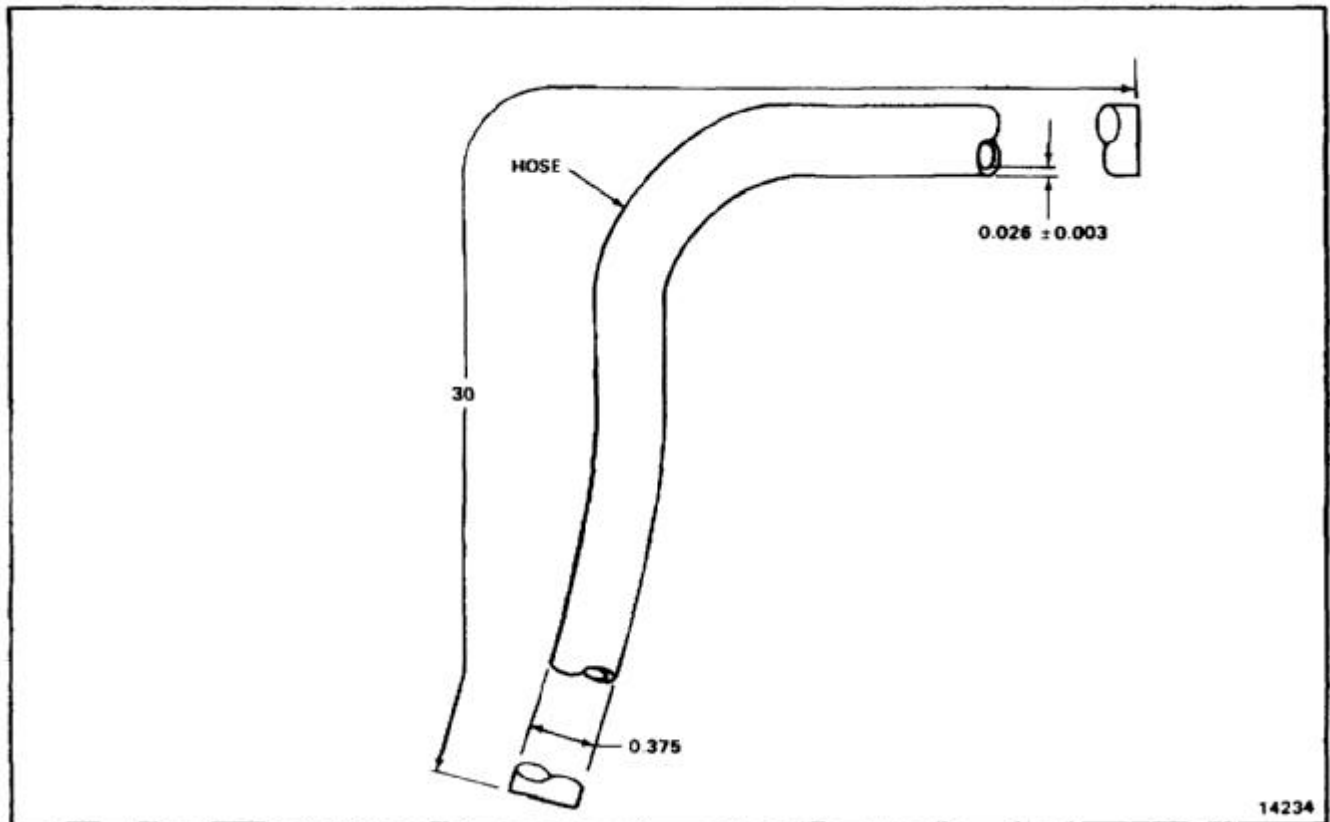

END OF TASK

NOTES:

1. FABRICATE FROM 6061-T6 SHEET ALUMINUM ALLOY QQ-A-250/11 TEMP T6.
2. ALL DIMENSIONS IN INCHES.
3. USE OLD SPACER AS TEMPLATE FOR MAKING HOLES.

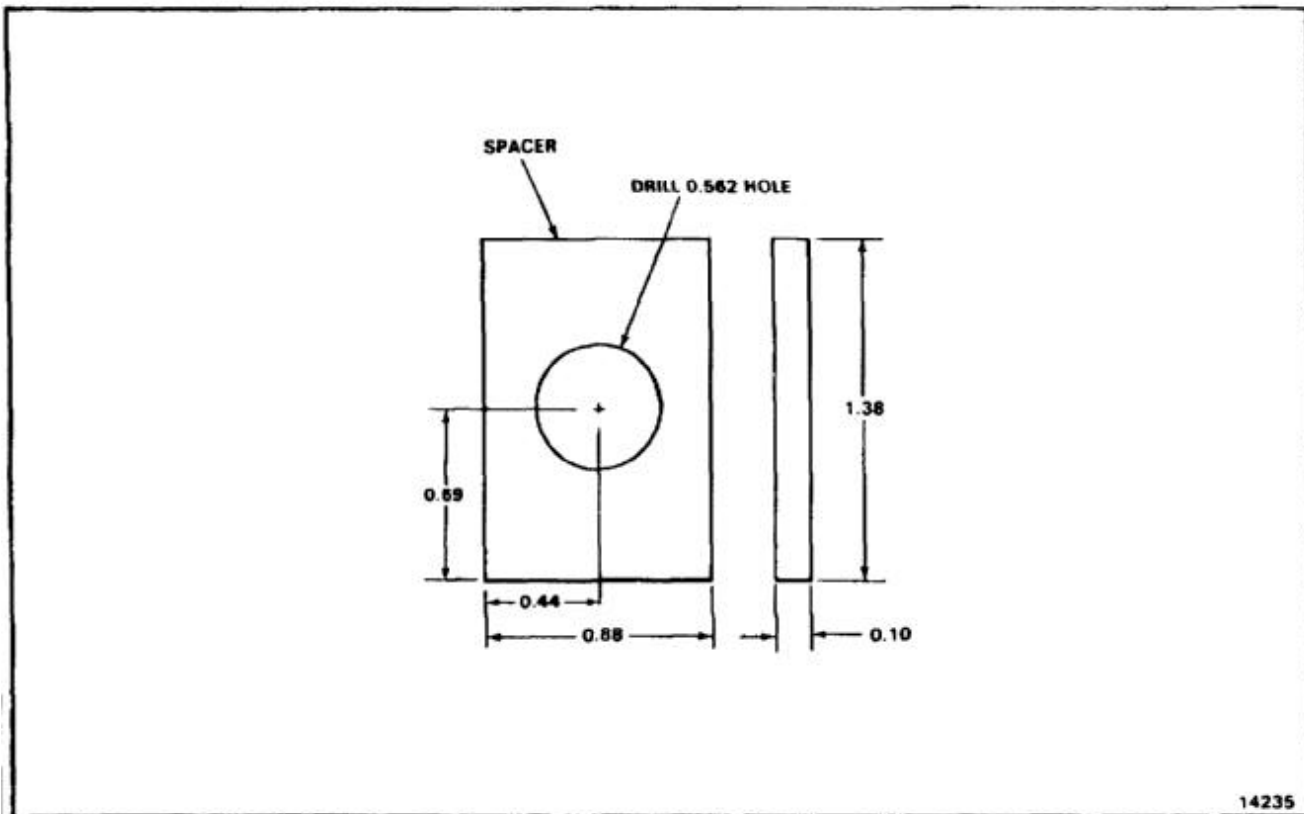

END OF TASK

NOTES:

1. FABRICATE FROM SILICONE RUBBER BMS 1-23, NSN 9320-01-064-6502 TO SPEC ASTM D 1056-85.
2. ALL DIMENSIONS IN INCHES.
3. STOCK SIZE 0.25 X 1.0 X 24.0.
4. CUT AND TRIM CUSHION TO FIT.
5. -9 CUSHION HAS BEEN CHANGED TO -27.

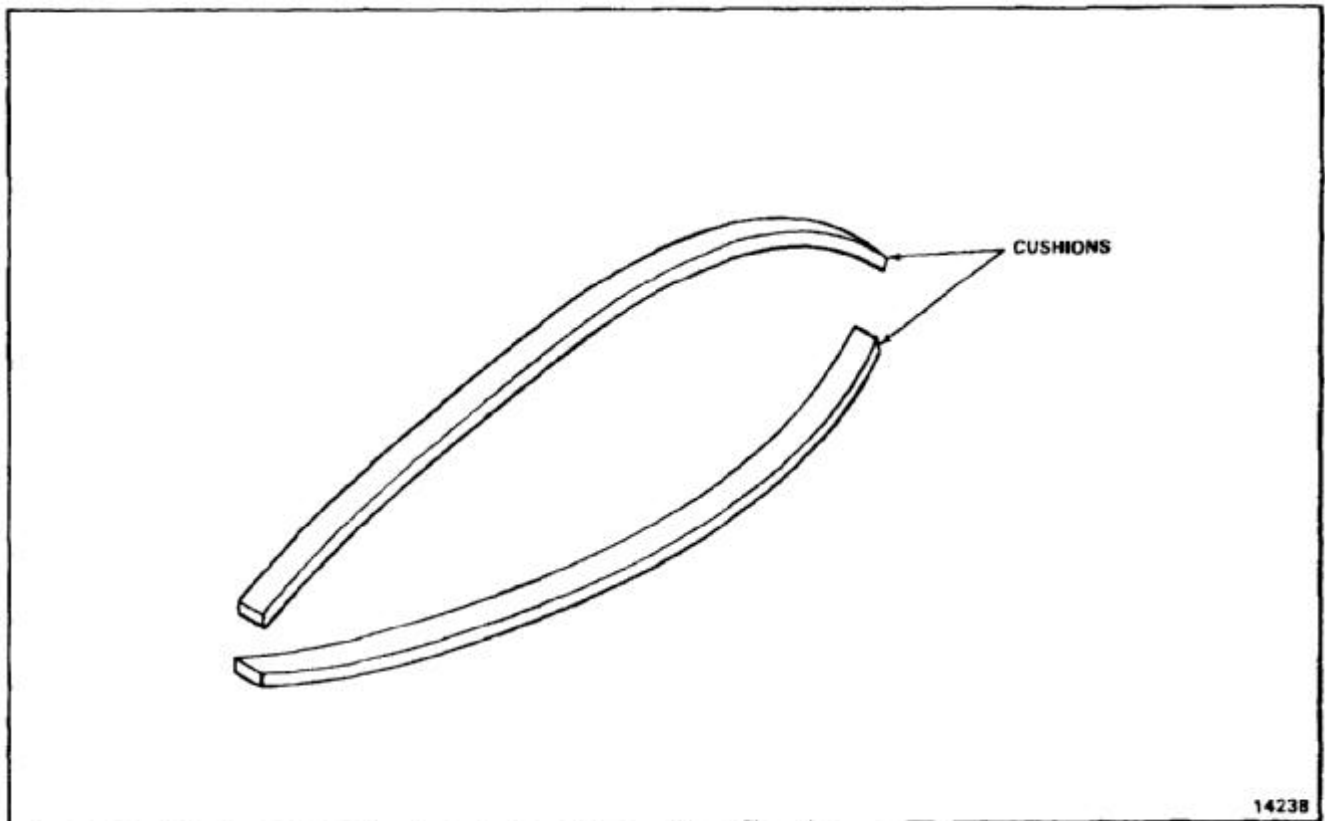

END OF TASK

NOTES:

1. FABRICATE CUSHION FROM SILICONE RUBBER BMS 1-23, NSN 9320-01-6502 TO SPEC ASTM D 1056-85.
2. ALL DIMENSIONS IN INCHES.
3. STOCK SIZE 0.25 X 9 X 18.
4. CUT AND TRIM CUSHION TO FIT.

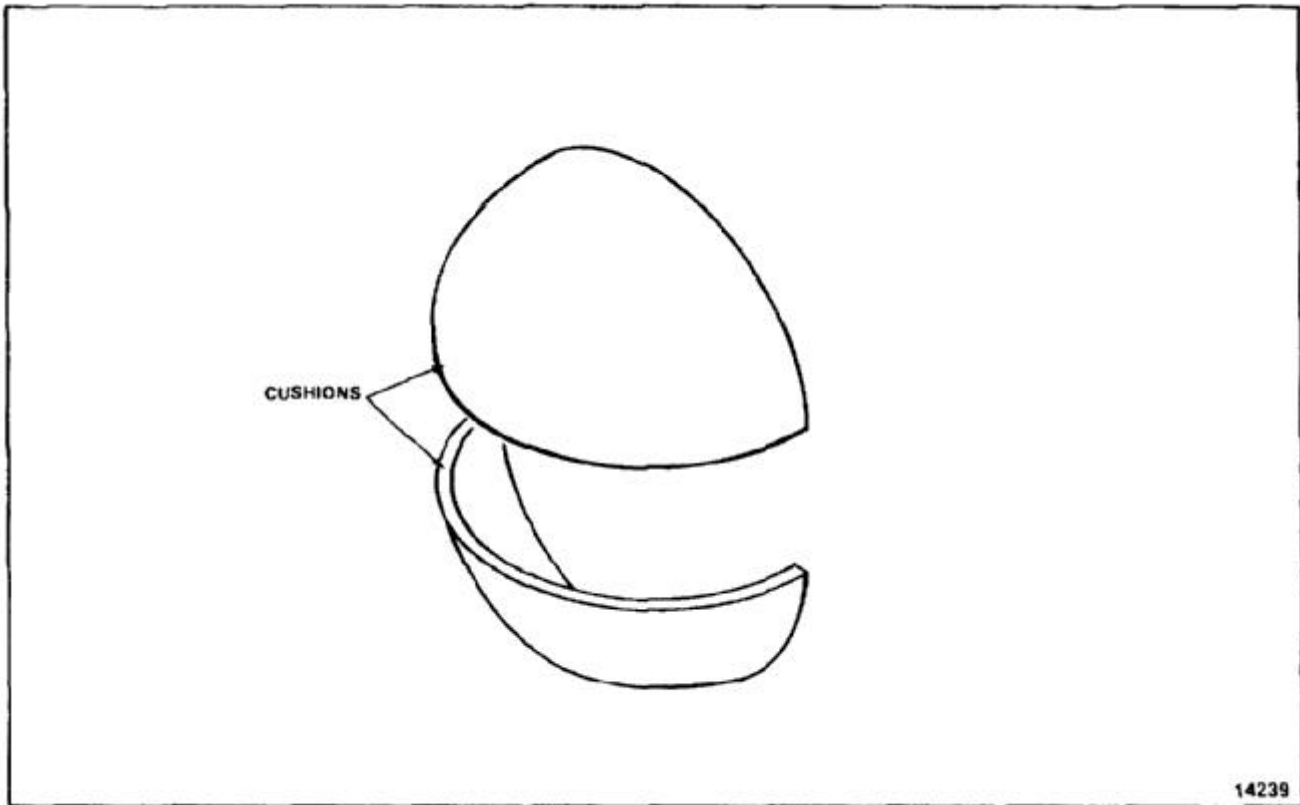

END OF TASK

NOTES:

1. FABRICATE FROM PURE TINNED STRANDED SOFT COPPER WIRE SIZE AWG 12 NSN 6145-819-0058.
2. ATTACH TERMINALS (MS25036-111, 112, 113, OR 114) TO WIRE WITH CRIMPING TOOL (MS25441).
3. TERMINAL NSN 5940-204-8890 ACCOMMODATES NUMBER 4 OR 6 SIZE STUD HOLE DIA 0.142 TO 0.152.
4. TERMINAL NSN 5940-204-8890 ACCOMMODATES NUMBER 4 OR 6 SIZE STUD HOLE DIA 0.142 TO 0.152.
5. ALL DIMENSIONS IN INCHES.

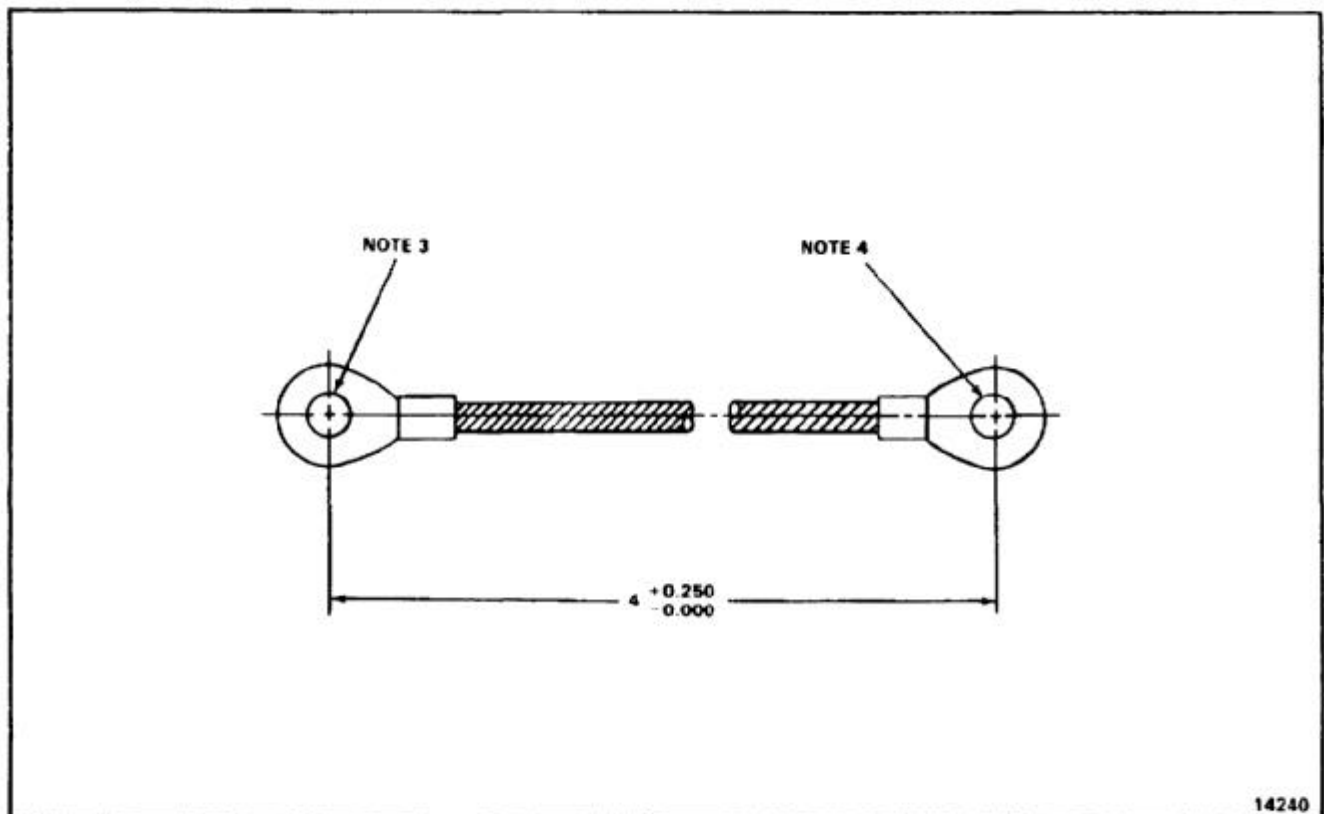

END OF TASK

NOTES:

1. MAKE -89 HALF HINGE FROM MS20257H P4-7200.
2. MAKE -91 HINGE PIN FROM MS20253-2-7200.
3. MAKE -63 HALF HINGE FROM MS20257H P4-7200.
4. USE OLD HINGE HALVES FOR TEMPLATES AND FOR MAKING HOLES IN NEW HINGES.
5. REMOVE CENTER LOBE. INSTALL SPRING 114P8039-2.
6. CRIMP ENDS OF PIN (E-60).
7. MAKE NEW HINGE SAME LENGTH AS ORIGINAL.
8. FINISH WITH YELLOW ZINC CHROMATE PRIMER (E-290).

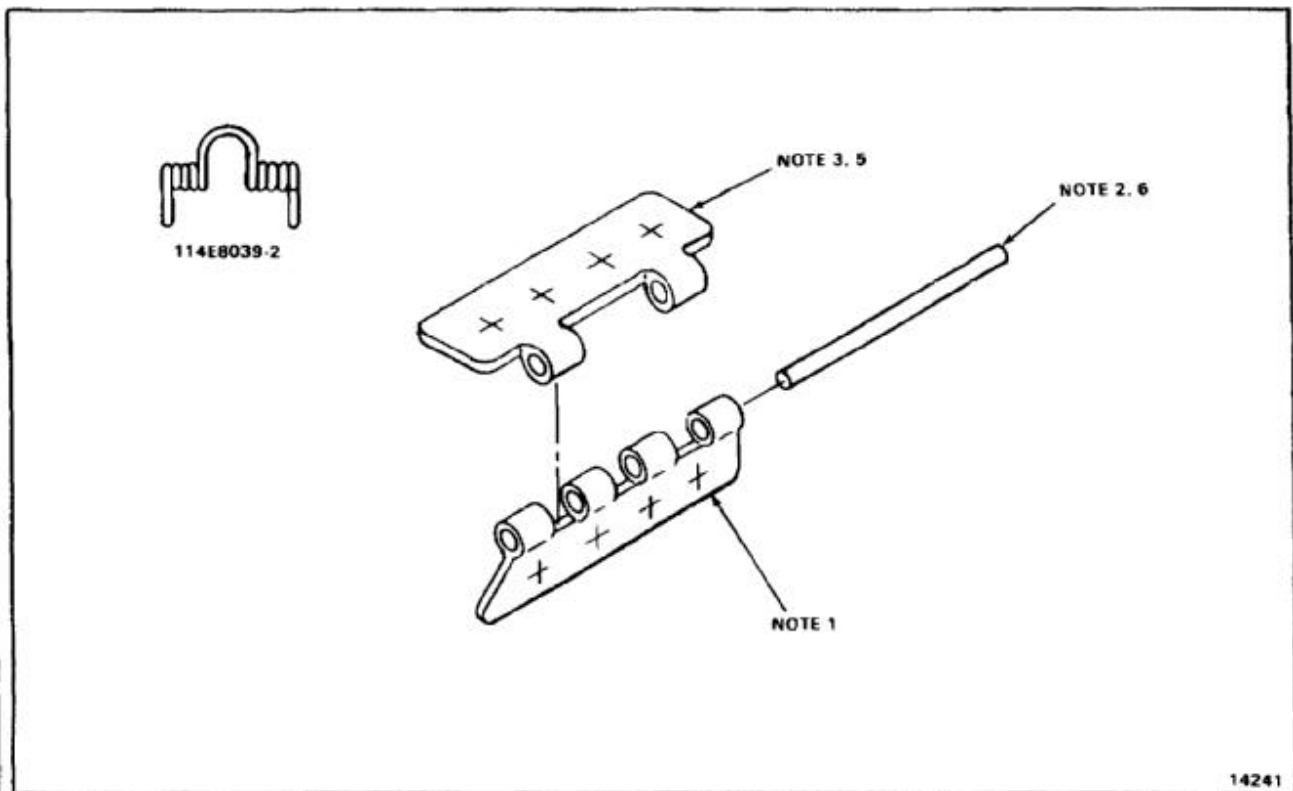

END OF TASK

NOTES:

1. MAKE -77 HALF HINGE FROM MS20257HP4-7200.
2. MAKE -93 HALF HINGE FROM MS20257HP4-7200.
3. MAKE -95 HINGE PIN FROM MS20253-2-7200.
4. USE OLD HINGE HALVES FOR TEMPLATES AND FOR MAKING HOLES IN NEW HINGES.
5. CRIMP ENDS OF PIN (E-60).
6. HINGE STOCK SIZE 1.50 WIDTH X 72 LENGTH.
7. PIN STOCK SIZE 0.089 DIA X 72 LENGTH.
8. MAKE NEW HINGE SAME LENGTH AS ORIGINAL.
9. FINISH WITH YELLOW ZINC CHROMATE PRIMER (E-290).

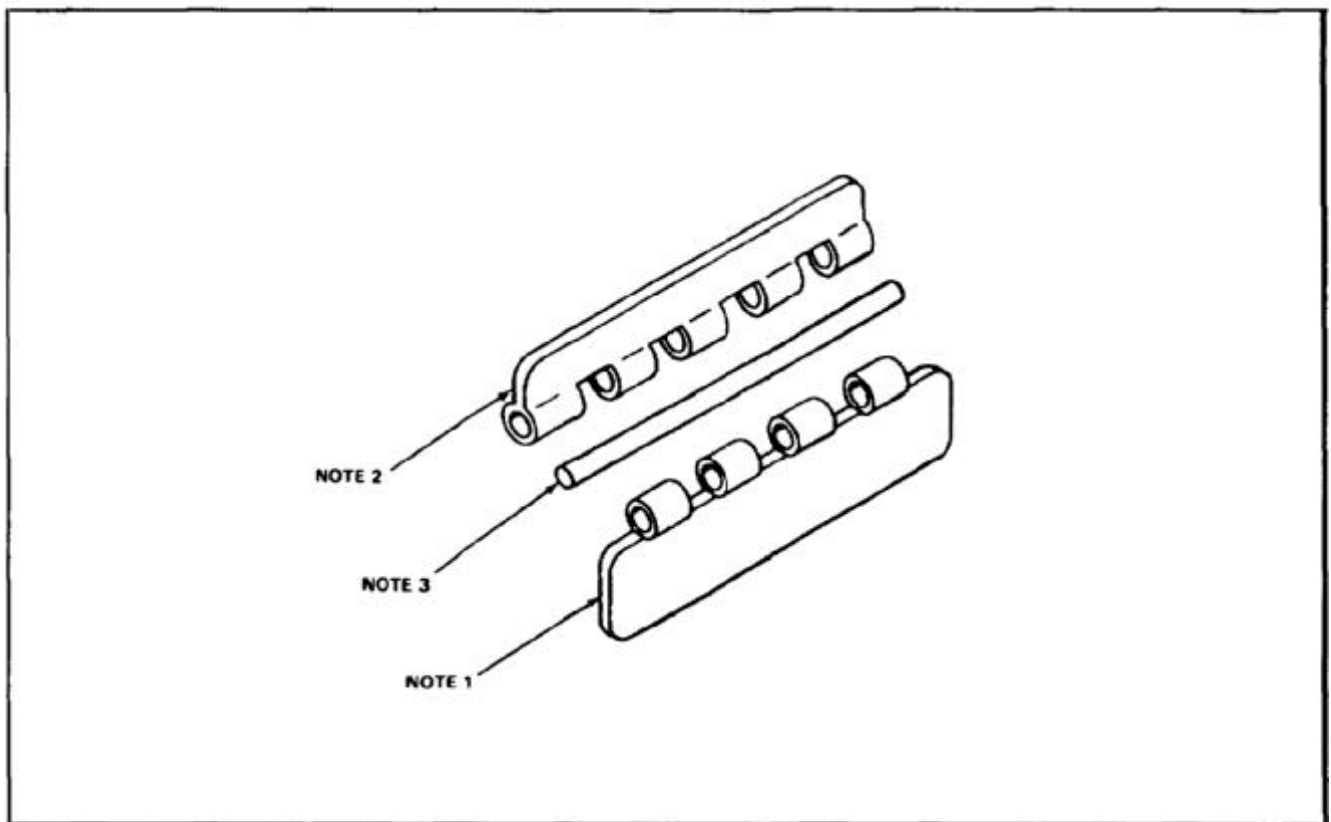

END OF TASK

NOTES:

1. FABRICATE FROM ALUMINUM ALLOY 2024-T4 CLAD SHEET.
2. ALL DIMENSIONS IN INCHES.
3. STOCK SIZE 0.063 X 2.2 X 3.1.
4. USE ORIGINAL FOR TEMPLATE WHEN MAKING REPLACEMENT.

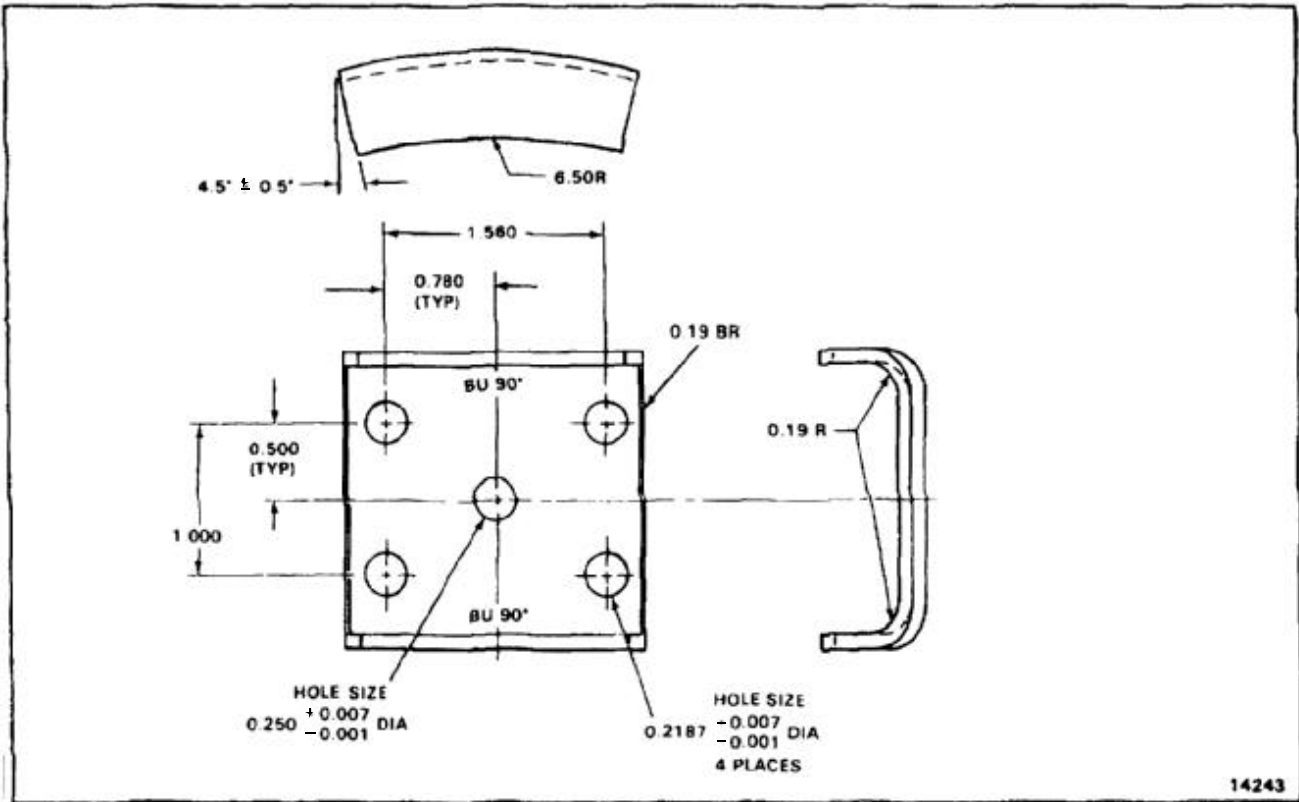

END OF TASK

NOTES:

1. FABRICATE FROM CRES STEEL CABLE TO SPEC MIL-C-5424.
2. ALL DIMENSIONS IN INCHES.
3. STOCK SIZE 0.0625 X 7 X 7 X 8.
4. MAKE REPLACEMENT CABLE AND LOOPS SAME LENGTH AS ORIGINAL.
5. SWAGE SLEEVES 28-1-C IN ACCORDANCE WITH SPEC MIL-T-6117.
6. INSTALL AND SWAGE AT INSTALLATION.

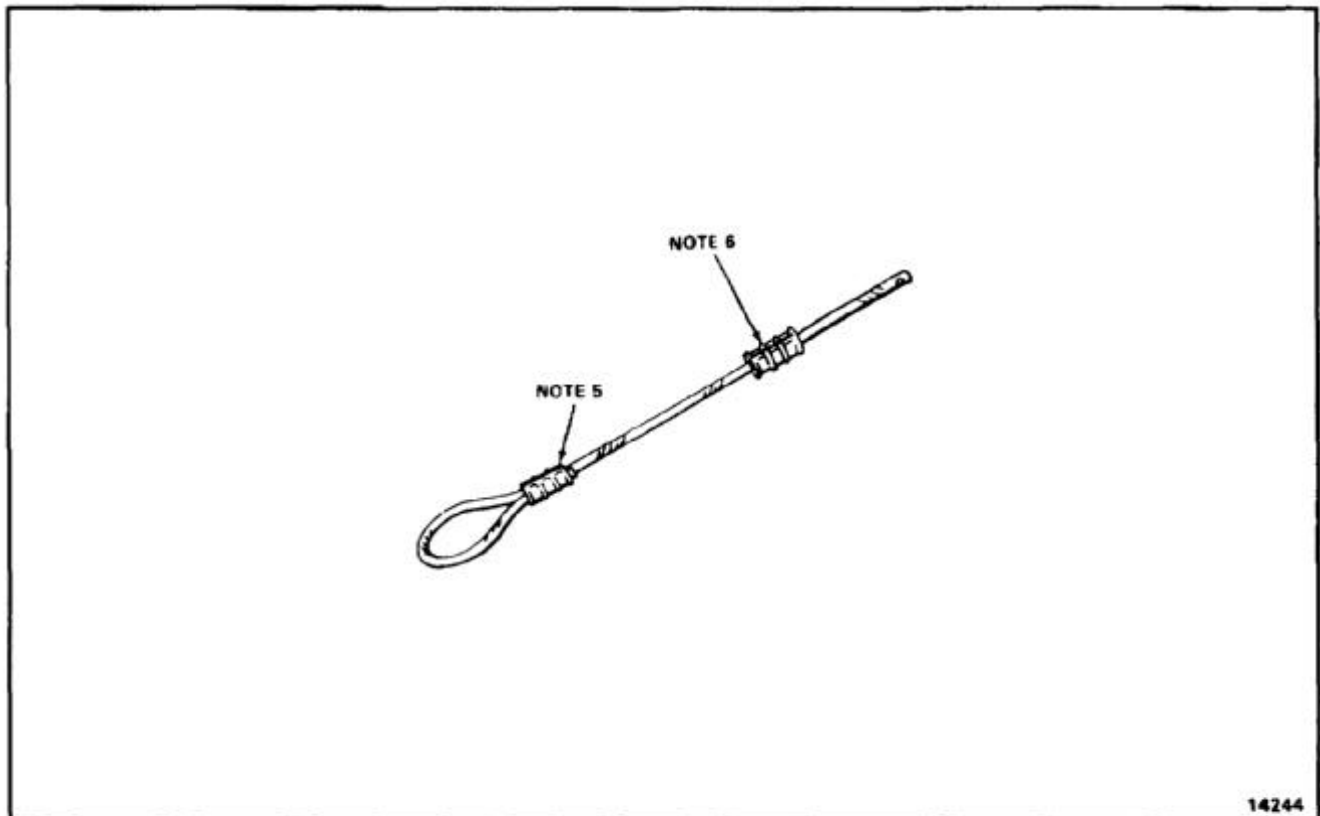

END OF TASK

NOTES:

1. FABRICATE FROM FLEXIBLE POLYVINYL CHLORIDE TUBING CLEAR COLOR.
2. ALL DIMENSIONS IN INCHES.
3. STOCK SIZE 0.375 OD X 0.062 WALL X 3.9 LENGTH.
4. CUT TO FIT.

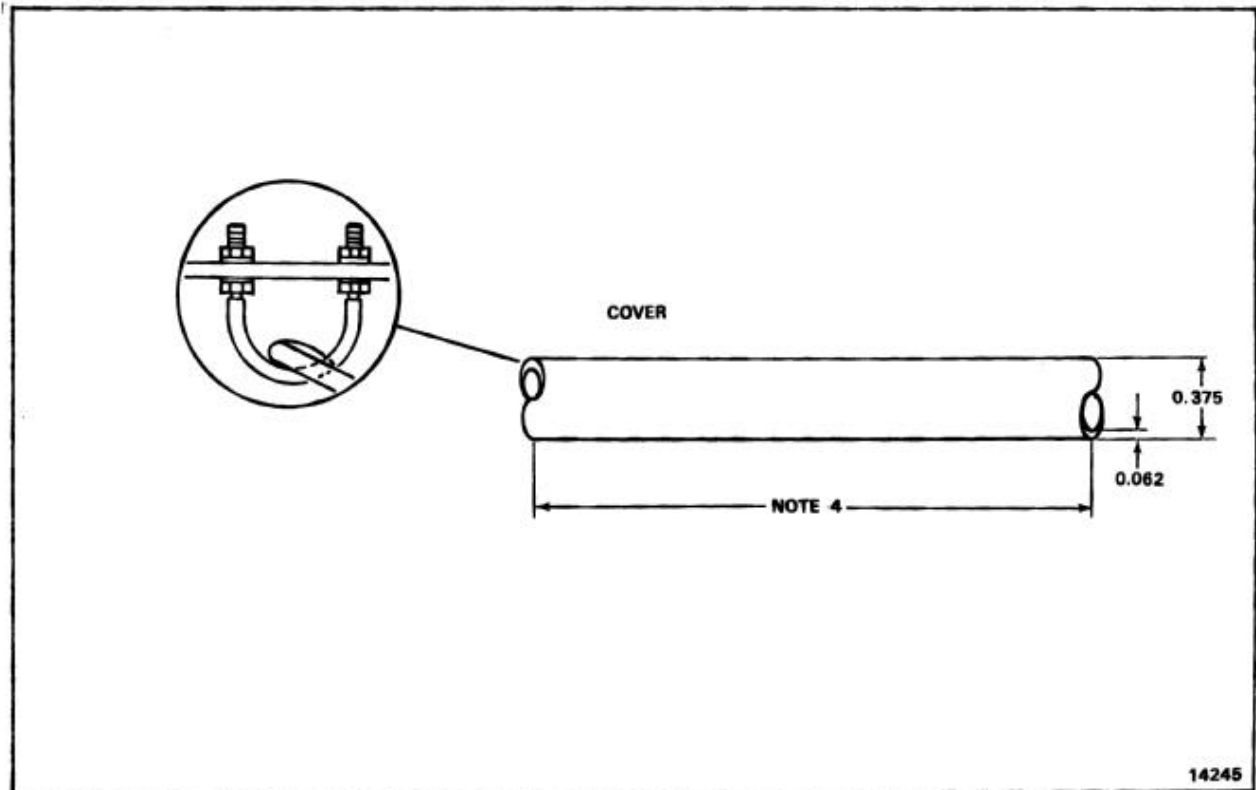

END OF TASK

E-172

NOTES:

1. FABRICATE FROM ALUMINUM ALLOY CLAD SHEET 2024-T3.
2. ALL DIMENSIONS IN INCHES.
3. STOCK SIZE 0.032 X 11.6 X 19.2.
4. USE OLD FRAME FOR TEMPLATE WHEN MAKING REPLACEMENT FRAME.
5. FINISH AS REQUIRED.

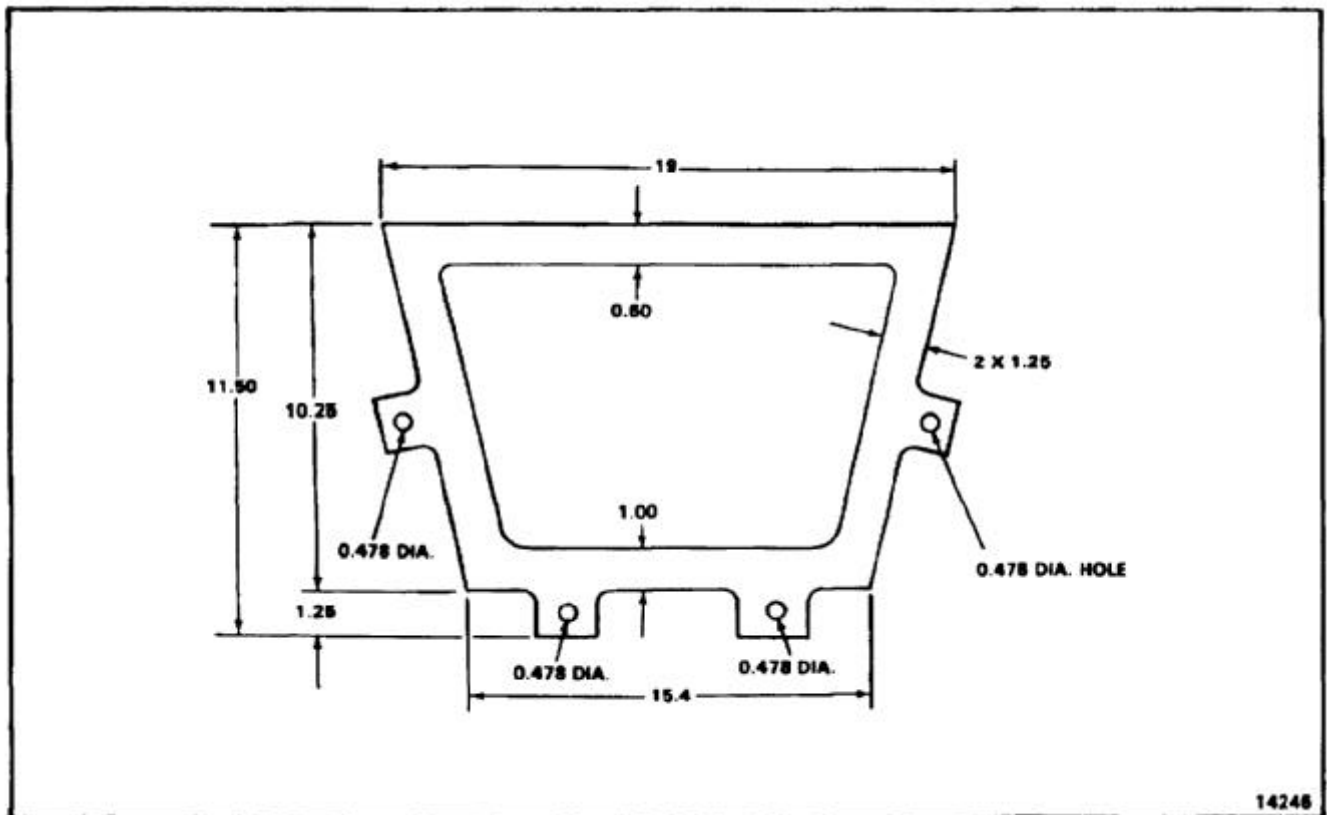

END OF TASK

NOTES:

1. FABRICATE FROM ALUMINUM ALLOY CLAD SHEET 2024-T3.
2. ALL DIMENSIONS IN INCHES.
3. STOCK SIZE 0.020 X 0.5 X 8.1.
4. CUT TO FIT.
5. FINISH AS REQUIRED.

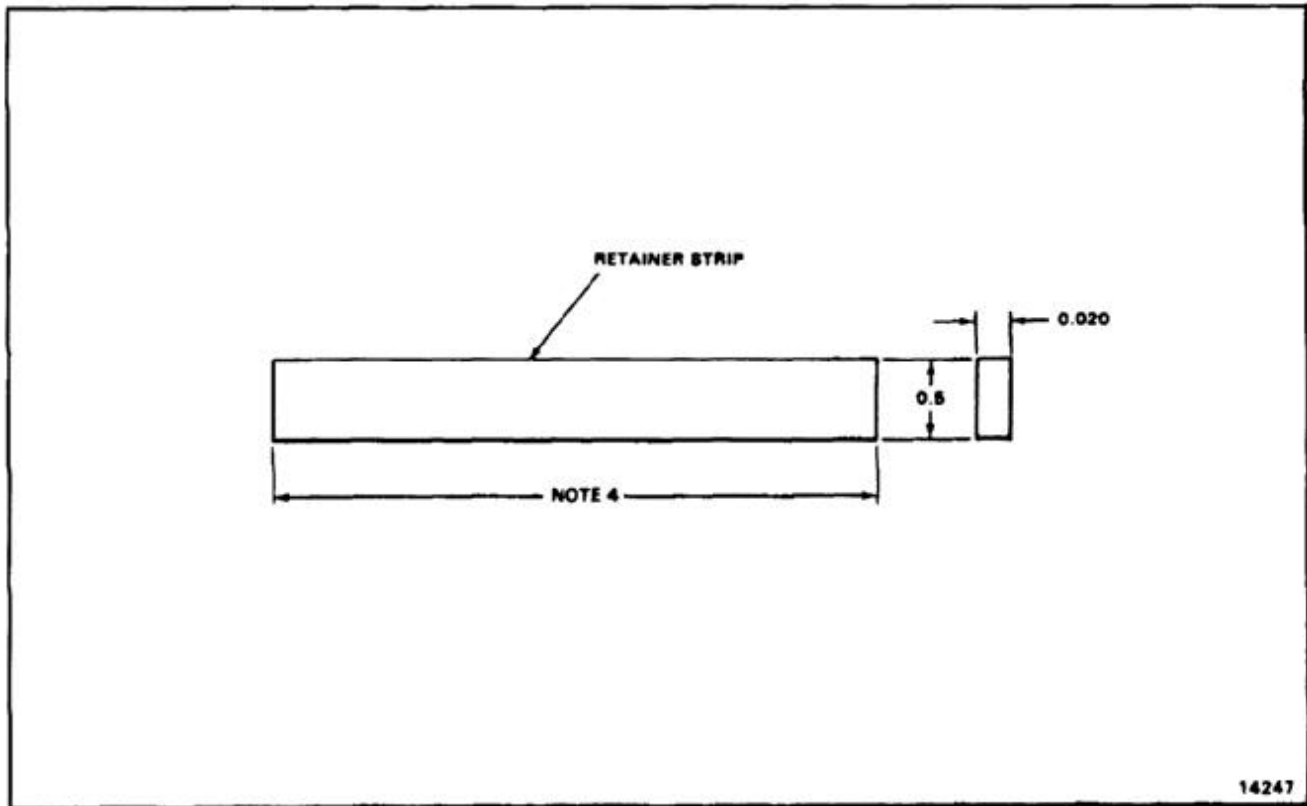

Task E-98 Deleted

END OF TASK

E-174

NOTES:

1. FABRICATE FROM TUBULAR WEBBING
0.070-10 MIL-W-5625-1000-BS.
2. ALL DIMENSIONS IN INCHES.
3. STOCK SIZE 0.5 X 4.5.
4. MAKE REPLACEMENT SAME LENGTH AS
ORIGINAL.

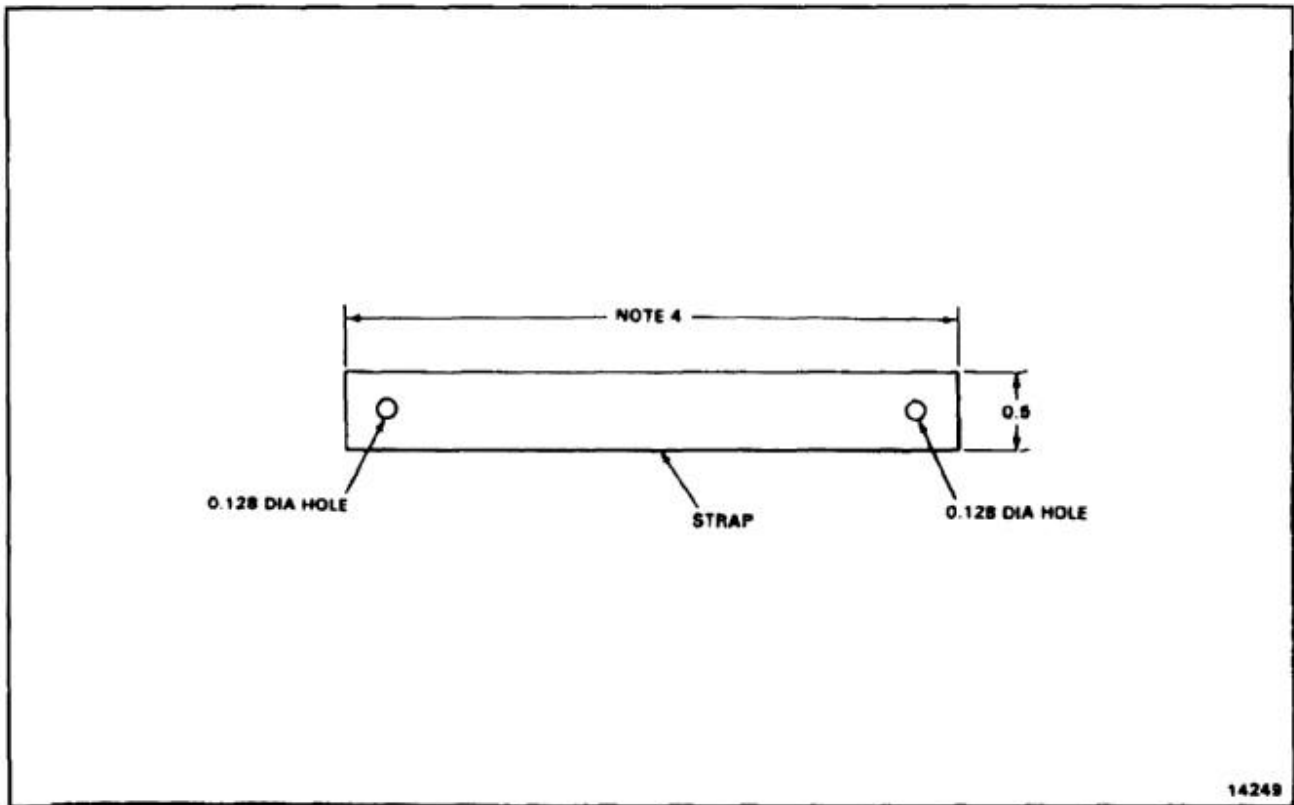

END OF TASK

NOTES:

1. FABRICATE FROM ALUMINUM ALLOY CLAD SHEET 2024-T3.
2. ALL DIMENSIONS IN INCHES.
3. STOCK SIZE 0.020 X 0.5 X 14.3.
4. MAKE REPLACEMENT SAME LENGTH AS ORIGINAL.
5. FINISH AS REQUIRED.

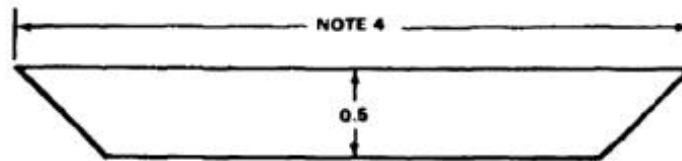

14250

END OF TASK

E-176

NOTES:

1. FABRICATE HINGE HALVES FROM ALUMINUM ALLOY 2024-T73511.
2. Y HALF HINGE MS20001 PY4-1700.
3. X HALF HINGE MS20001 PX4-1700.
4. HINGE PIN MS20253 P2-1680 MADE FROM CAD PLATED CRES STEEL.
5. ALL DIMENSIONS IN INCHES.
6. STAKE PIN TO SPEC MS33540.
7. FINISH WITH YELLOW ZINC CHROMATE PRIMER (E-290).

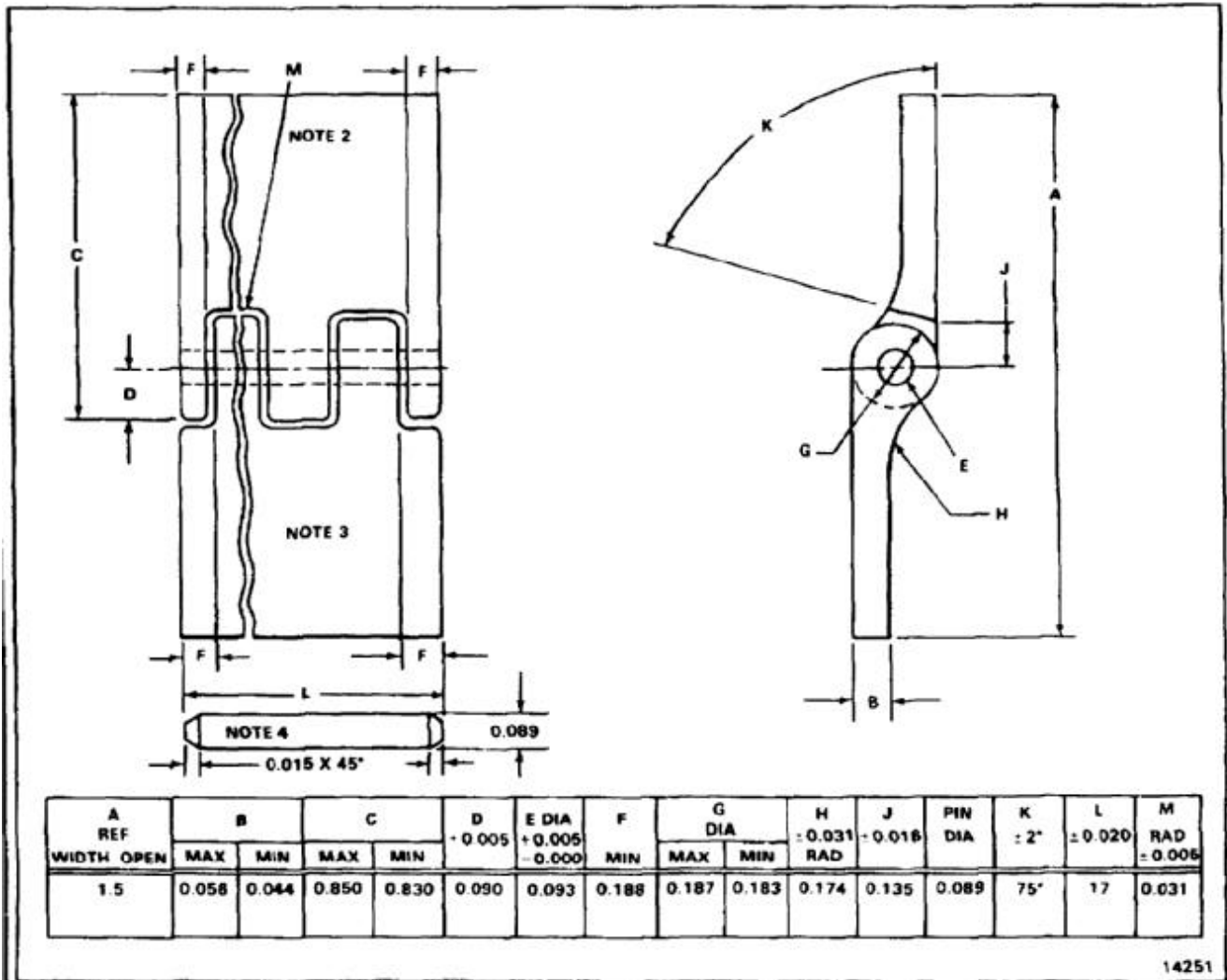

14251

END OF TASK

NOTES:

1. FABRICATE FROM AISI-301 CORROSION RESISTANT SHEET TO SPEC MIL-S-5059 COMP 301, 1/2 HARD.
2. ALL DIMENSIONS IN INCHES.
3. STOCK SIZE 0.050 X 2.25 X 3.60.

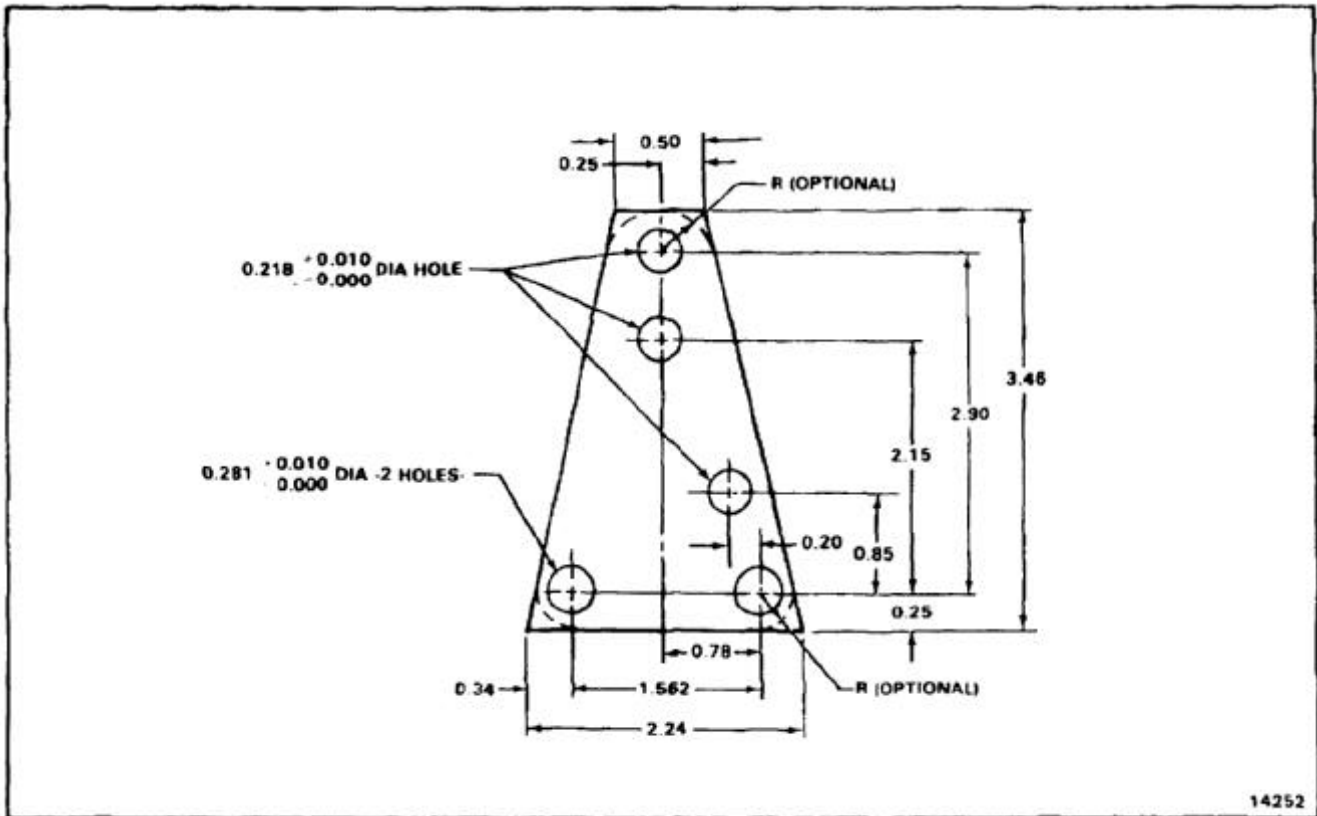

14252

END OF TASK

NOTES:

1. FABRICATE FROM AISI-301 CORROSION RESISTANT SHEET TO SPEC MIL-S-5059 COMP 301, 1/2 HARD.
2. ALL DIMENSIONS IN INCHES.
3. STOCK SIZE 0.050 x 1.70 x 2.10.

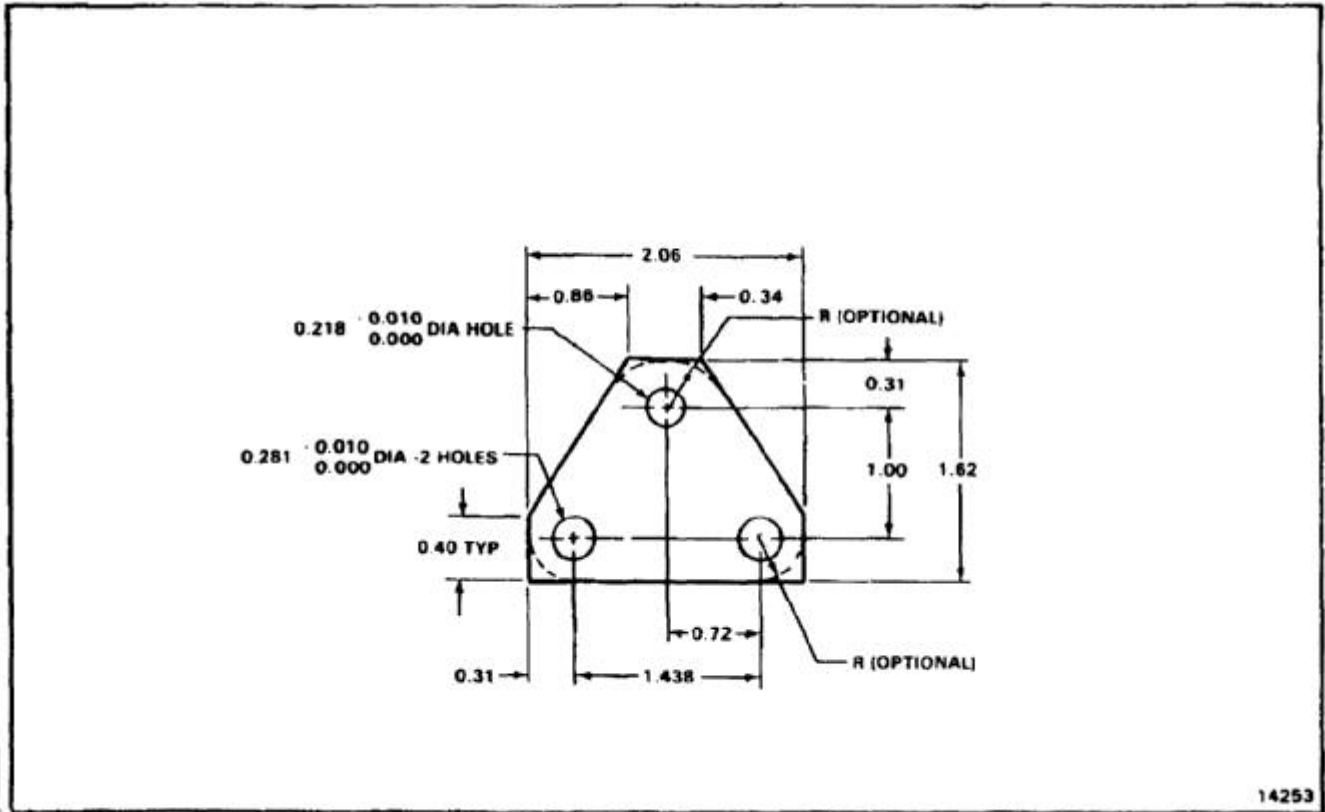

END OF TASK

NOTES:

1. MADE FROM ALUMINUM ALLOY 2024-T3511.
2. H TYPE HALF HINGE M52001-PH4.
3. HINGE PIN MS20253 P2-1680 MADE FROM CAD PLATED CRES STEEL.
4. ALL DIMENSIONS IN INCHES.
5. FINISH WITH YELLOW ZINC CHROMATE PRIMER (E-290).

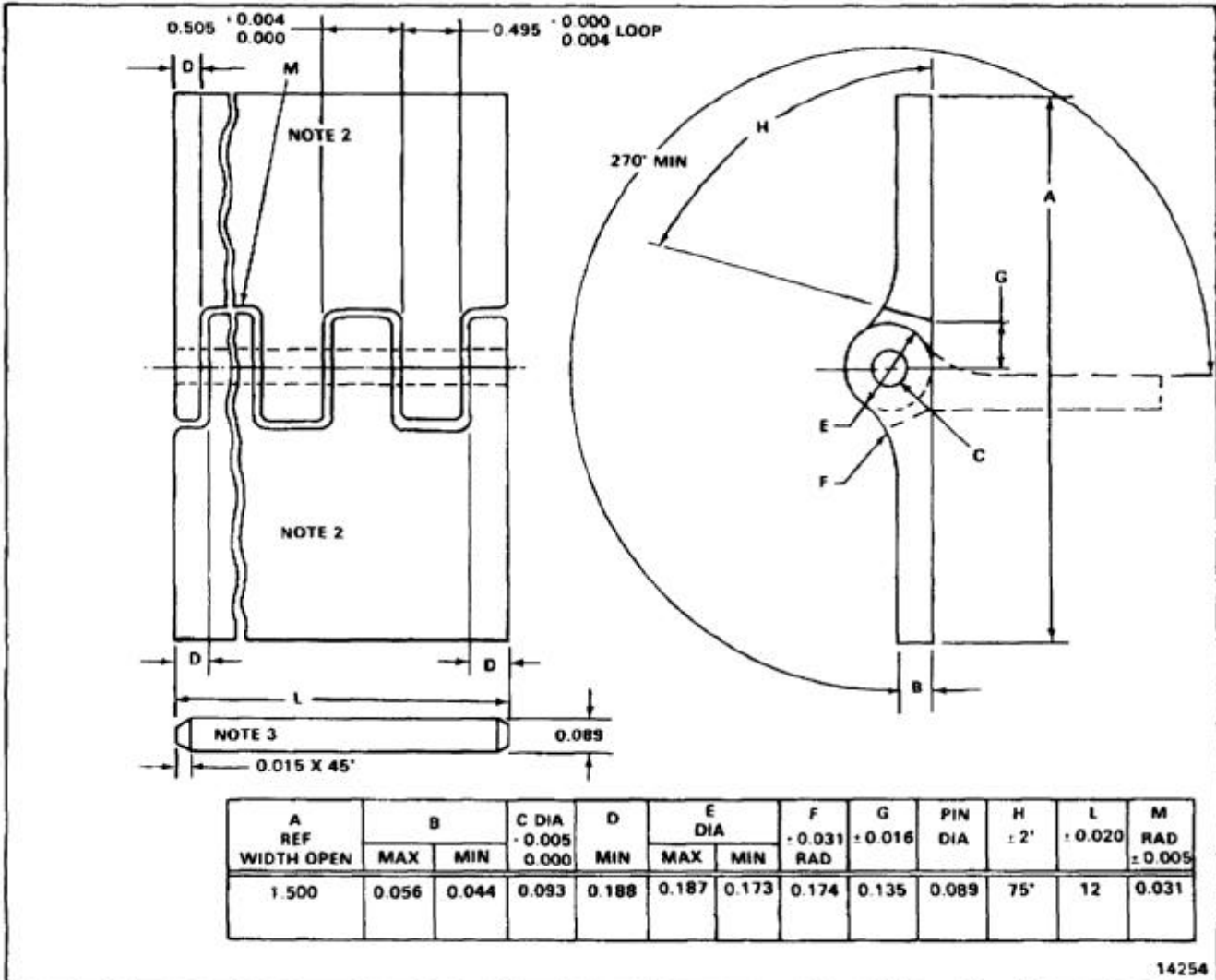

14254

END OF TASK

E-180

NOTES:

1. MADE OF SILICONE RUBBER ZZ-R-765 CLASS 1b, GRADE 40.
2. ALL DIMENSIONS IN INCHES.
3. STANDARD SHAPE VS80572 LENGTH 31, COLOR GRAY.
4. CUT SEAL TO FIT.

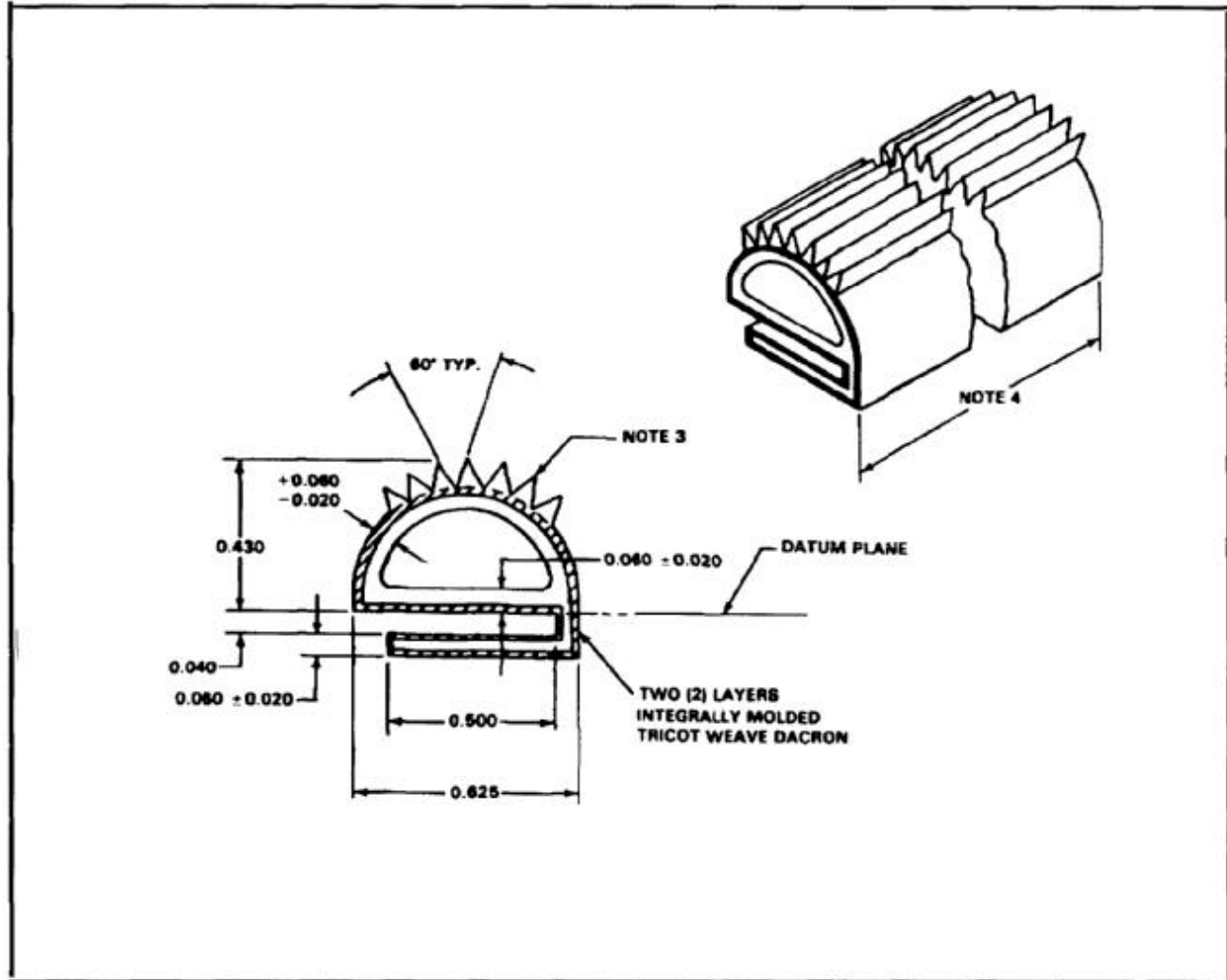

END OF TASK

NOTES:

1. MADE OF SILICONE RUBBER ZZ-R-765
CLASS III, GRADE 80.
2. ALL DIMENSIONS IN INCHES.
3. STANDARD SHAPE VS80570-2 LENGTH 120,
COLOR BLACK.
4. CUT SEAL TO FIT.

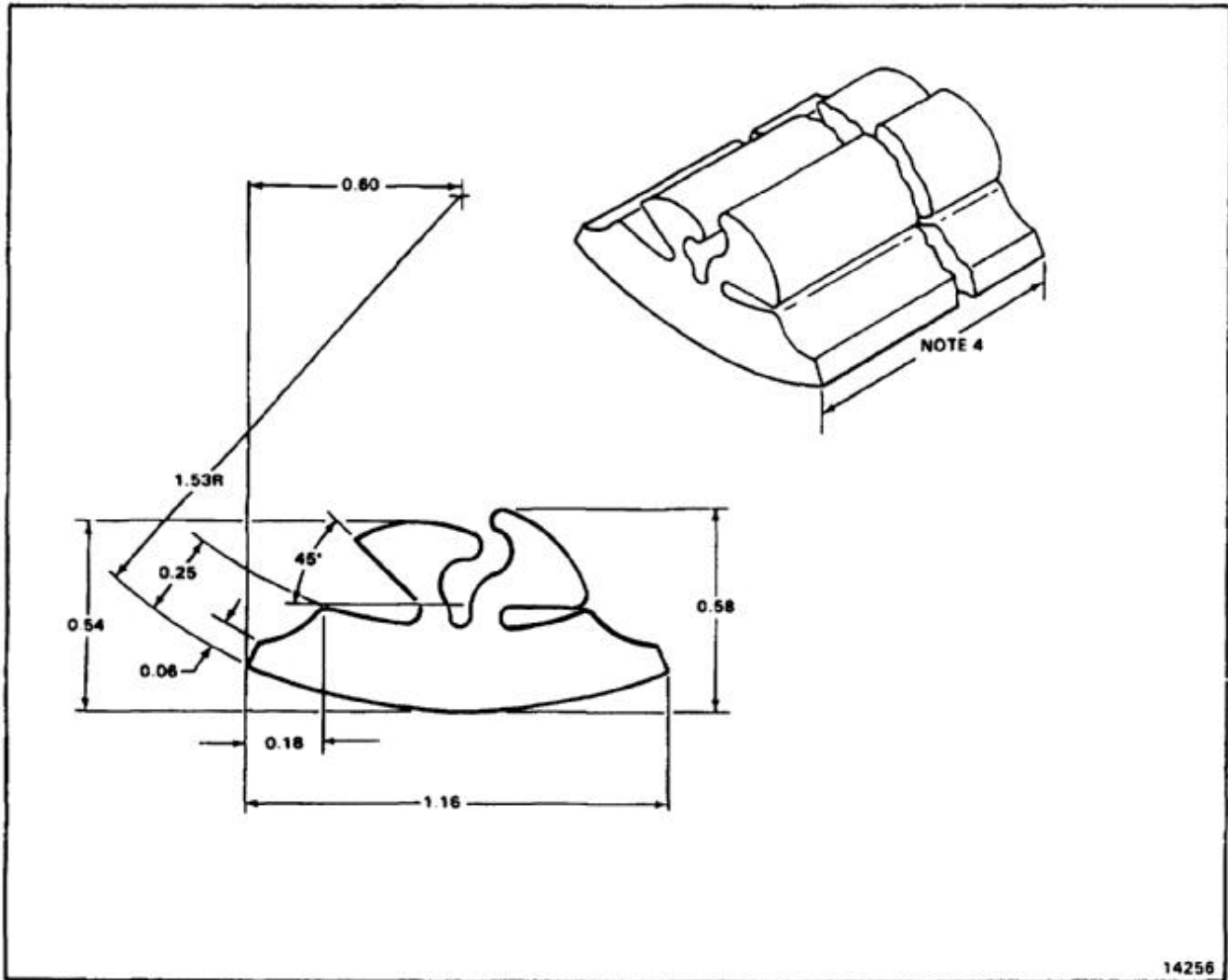

END OF TASK

E-182

NOTES:

1. FABRICATE FROM ALUMINUM ALLOY CLAD SHEET 2024-T3.
2. ALL DIMENSIONS IN INCHES.
3. STOCK SIZE 0.025 X 2.5 X 8.0.
4. USE ORIGINAL RETAINER FOR TEMPLATE IN LOCATING RIVET HOLES IN REPLACEMENT.

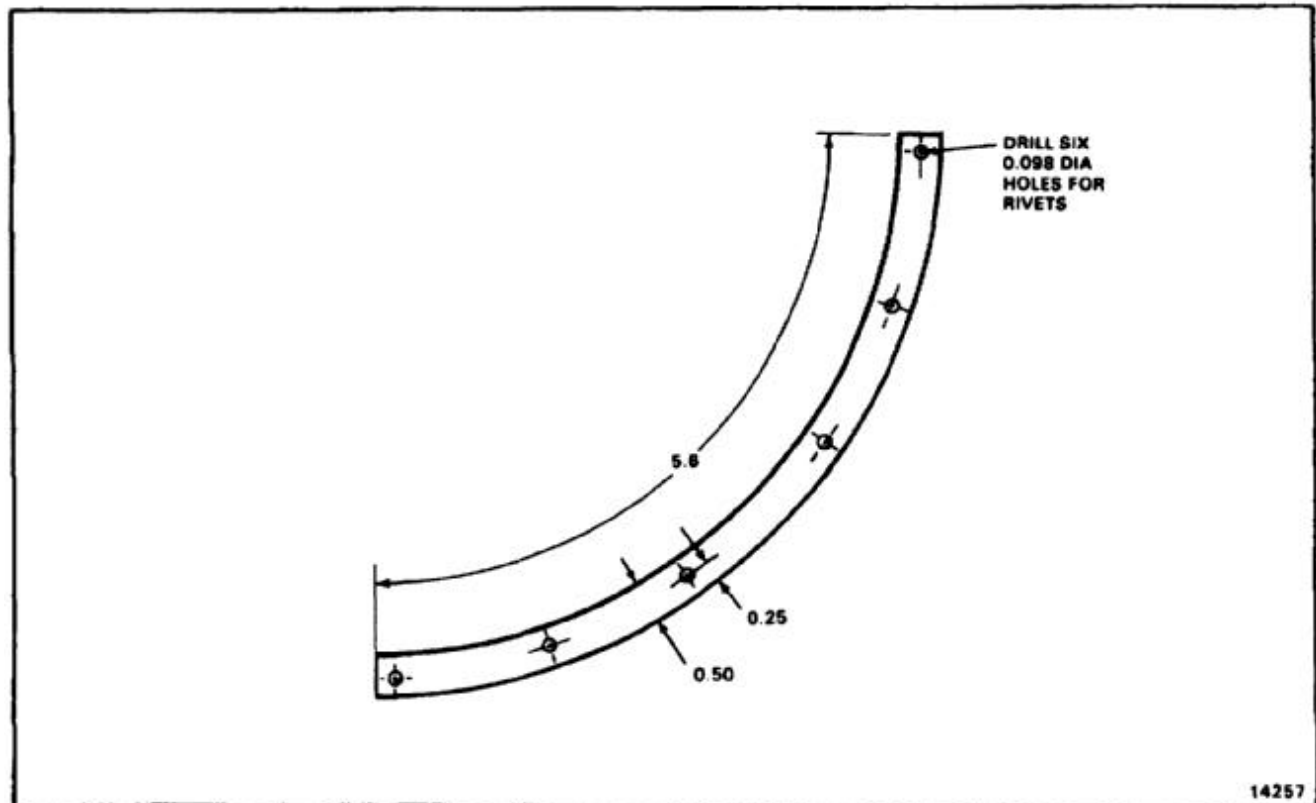

END OF TASK

NOTES:

1. MADE OF SILICONE RUBBER ZZ-R-765 CLASS 1b, GRADE 40.
2. ALL DIMENSIONS IN INCHES.
3. STANDARD SHAPE VS80572-1, LENGTH 85, COLOR GRAY.
4. CUT SEAL TO FIT.

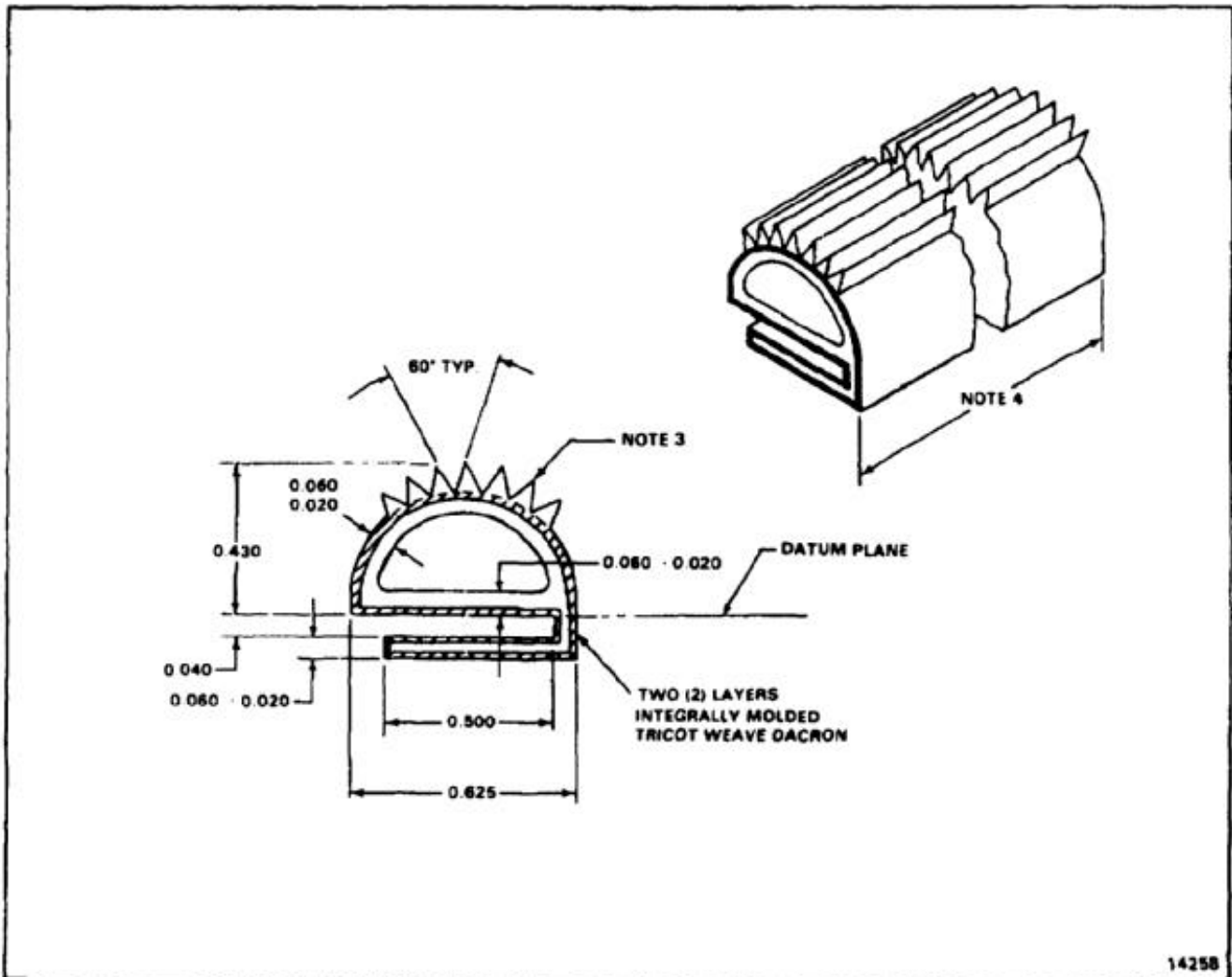

END OF TASK

NOTES:

1. FABRICATE FROM PURE TINNED STRANDED SOFT COPPER WIRE SIZE AWG12, NSN 6145-819-0058.
2. ATTACH TERMINALS (M525036-111, 112, 113, 114, 156, OR 157) TO WIRE WITH CRIMPING TOOL (MS25441).
3. TERMINAL NSN 5940-00-204-8990 ACCOMMODATES NUMBER 4 OR 6 SIZE STUD. HOLE DIA 0.142 TO 0.152.
4. TERMINAL NSN 5940-00-143-4795 ACCOMMODATES NUMBER 8 SIZE STUD. HOLE DIA 0.193 TO 0.203.
5. TERMINAL NSN 5940-00-143-4794 ACCOMMODATES NUMBER 10 SIZE STUDS.
6. ALL DIMENSIONS IN INCHES.

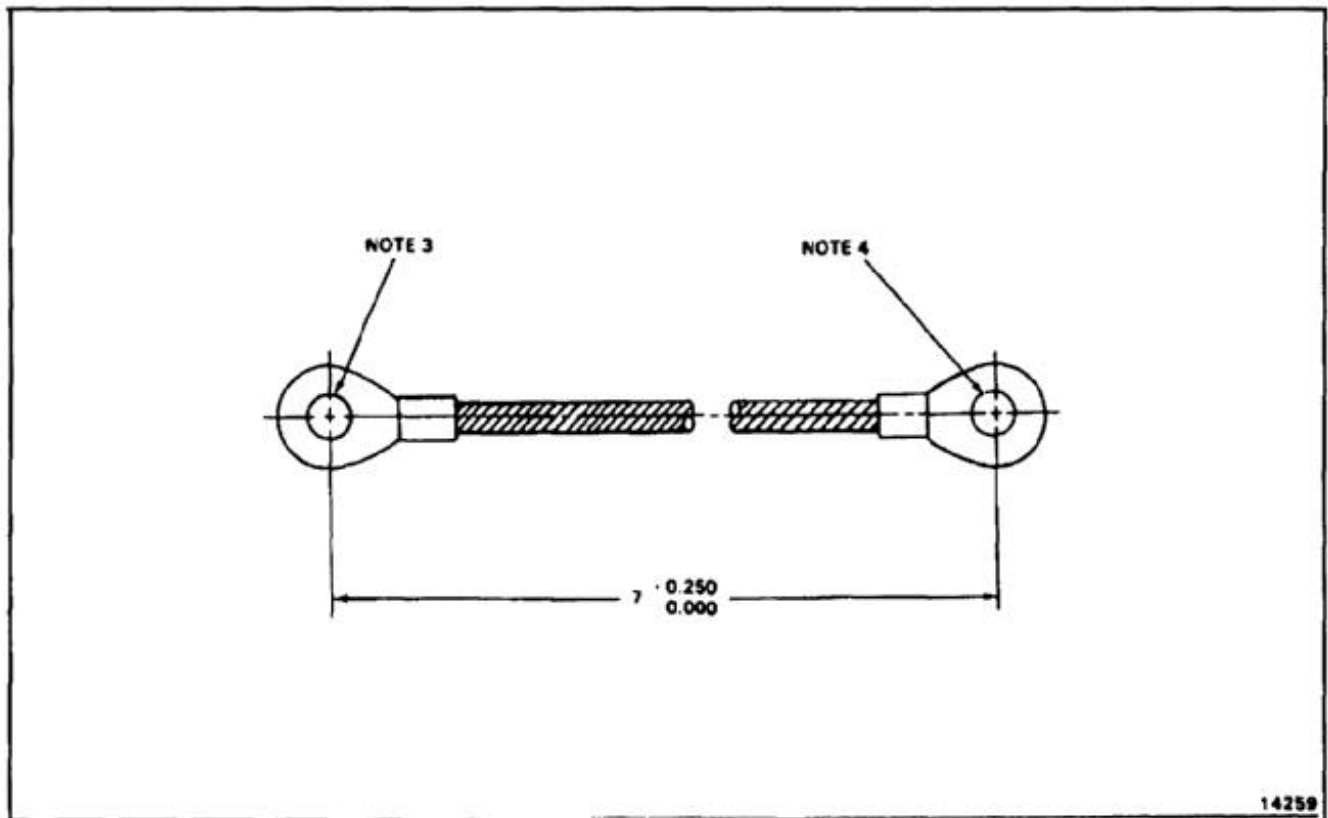

END OF TASK

NOTES:

1. FABRICATE FROM FELT STRIP TYPE 1, CLASS 12R1, NSN 5330-00-530-4341.
2. ALL DIMENSIONS IN INCHES.
3. °CUT ENDS TO OVERLAP AT 45 ± 0 ANGLES 5 AS INDICATED.
4. CUT STRIP TO MATCH PERIPHERY OF ROD.

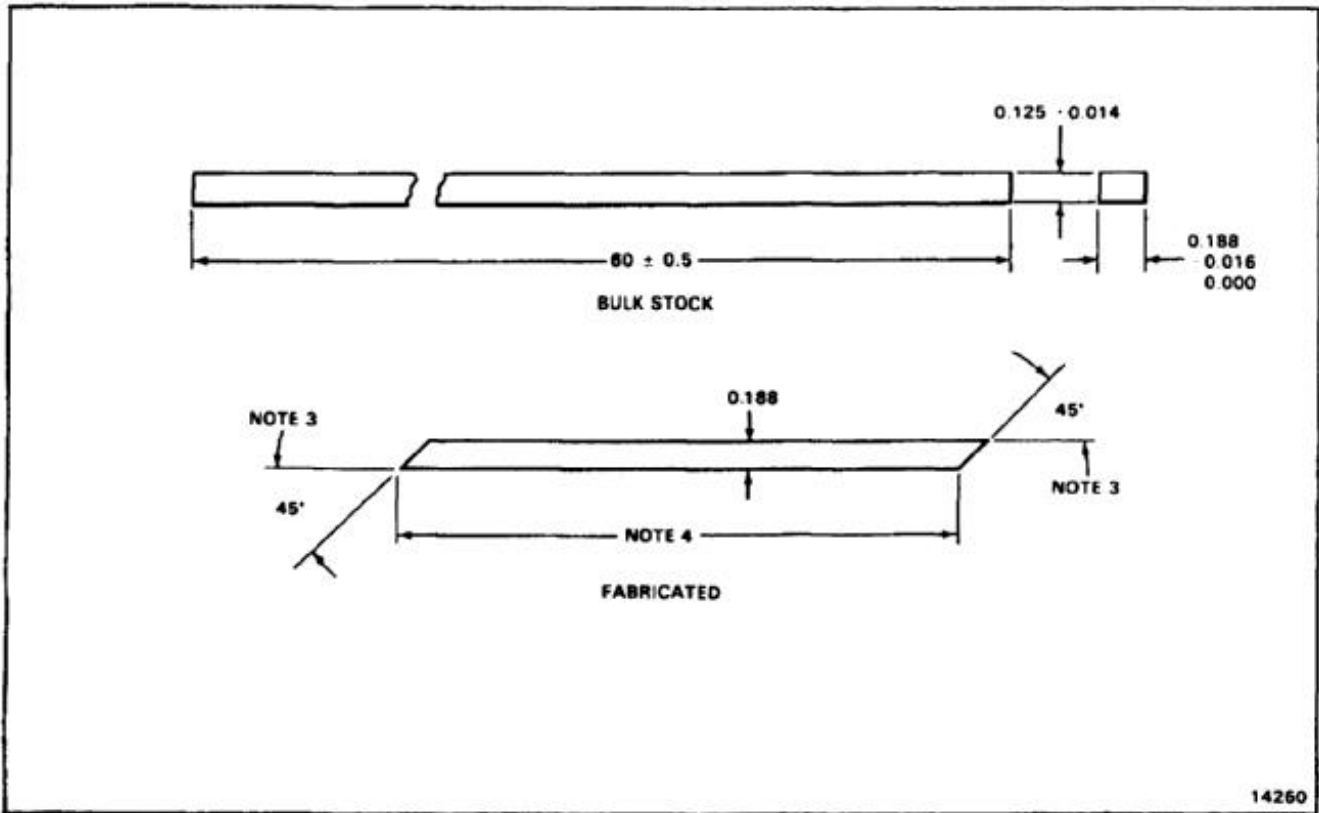

END OF TASK

NOTES:

1. FABRICATE FROM PURE TINNED STRANDED SOFT COPPER WIRE SIZE AWG12, NSN 6145-00-819-0058.
2. ATTACH TERMINALS (MS25036-111, 112, 113, 114, 156, OR 157) TO WIRE WITH CRIMPING TOOL (MS25441).
3. TERMINAL HOLE ACCOMMODATES NUMBER 4 OR 6 SIZE STUD NSN 5940-00-204-8990.
4. STUD HOLE (ID) REQUIRED IN TERMINAL NSN 5940-00-143-4777 IS 0.250.
5. ALL DIMENSIONS IN INCHES.

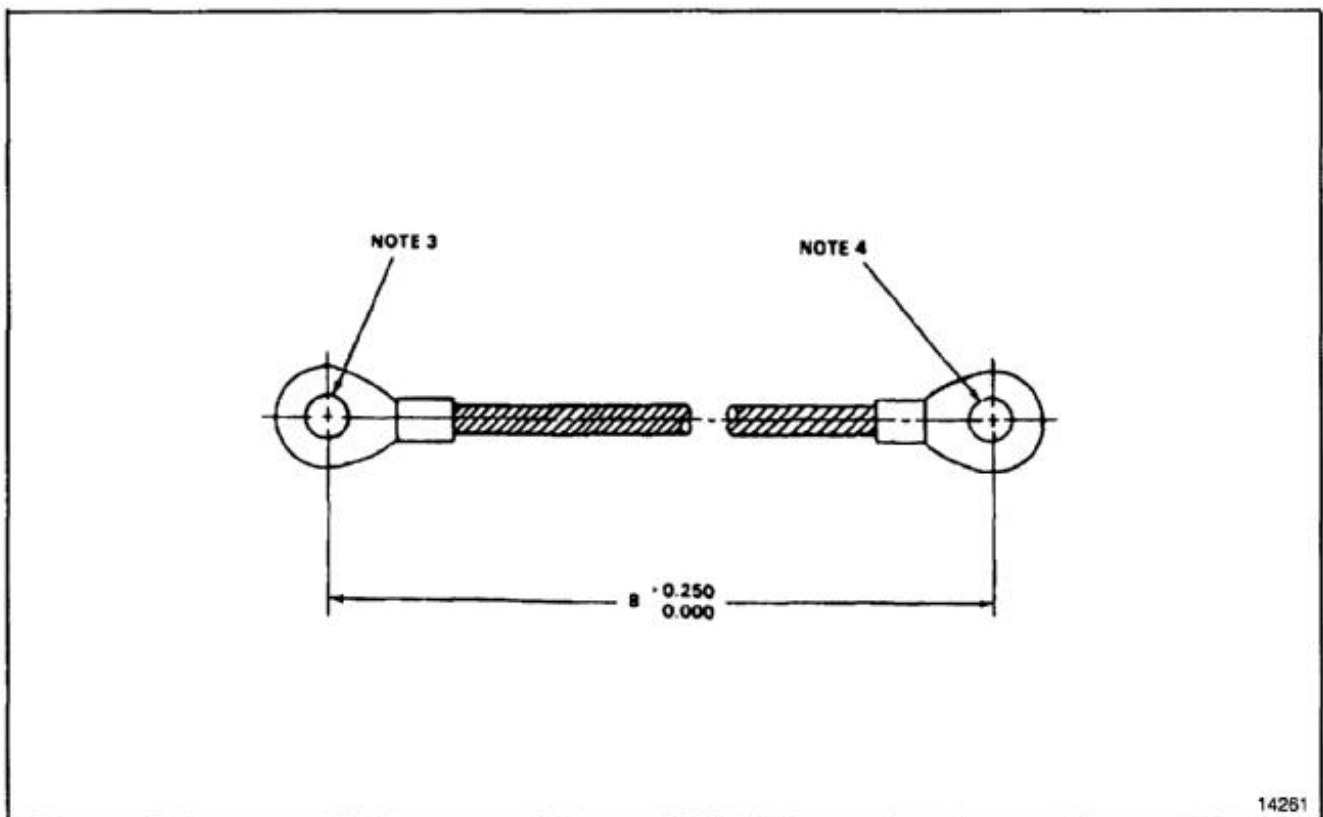

14261

END OF TASK

NOTES:

1. FABRICATE FROM SILICONE RUBBER
TRICOT KNOT DACRON FABRIC OR
EQUIVALENT.
2. COLOR BLACK STANDARD SHAPE
BAC1530-86.
3. ALL DIMENSIONS IN INCHES.
4. STOCK LENGTH 35.9. CUT SEAL TO FIT.

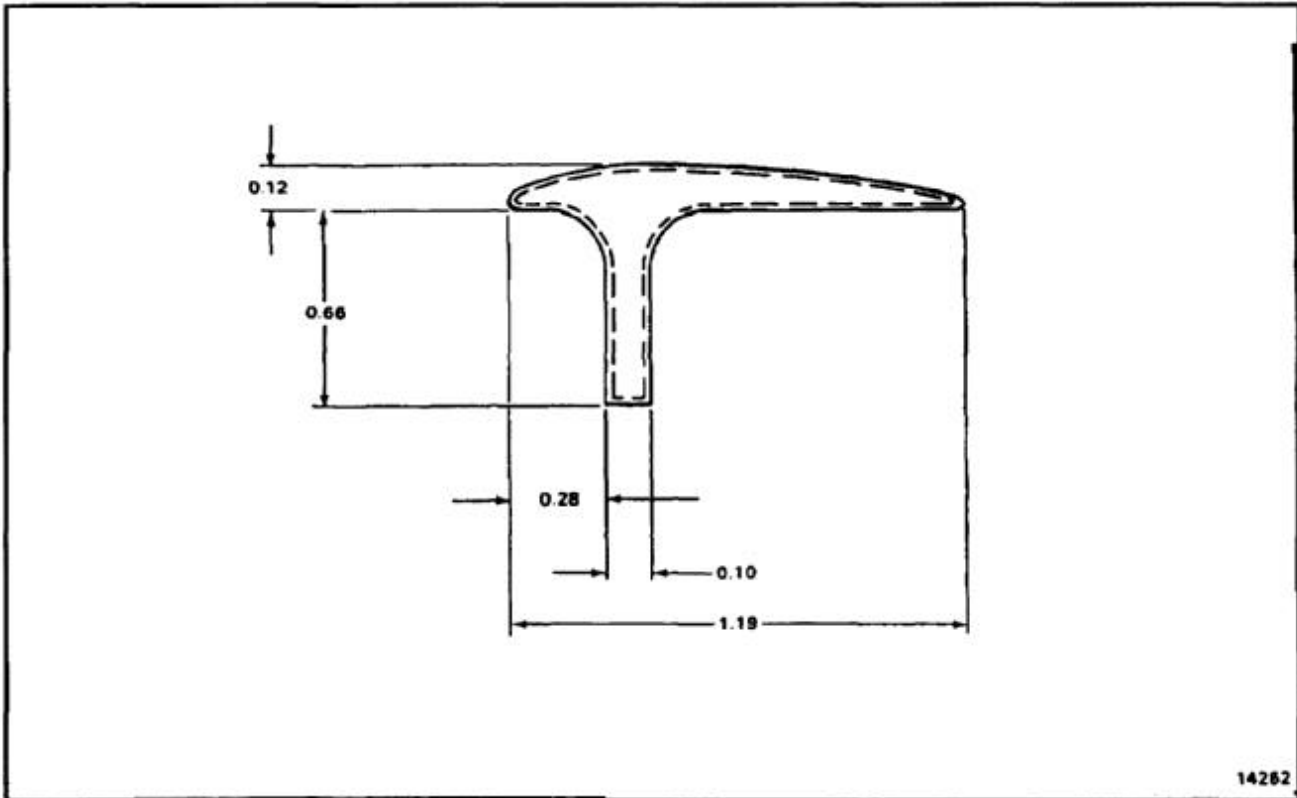

END OF TASK

NOTES:

1. MADE OF SILICON RUBBER MIL-R-5847, CLASS III, GRADE 50.
2. ALL DIMENSIONS IN INCHES.
3. STANDARD SHAPE VS80546-1 LENGTH 6.6, COLOR BLACK.
4. CUT SEAL TO FIT.

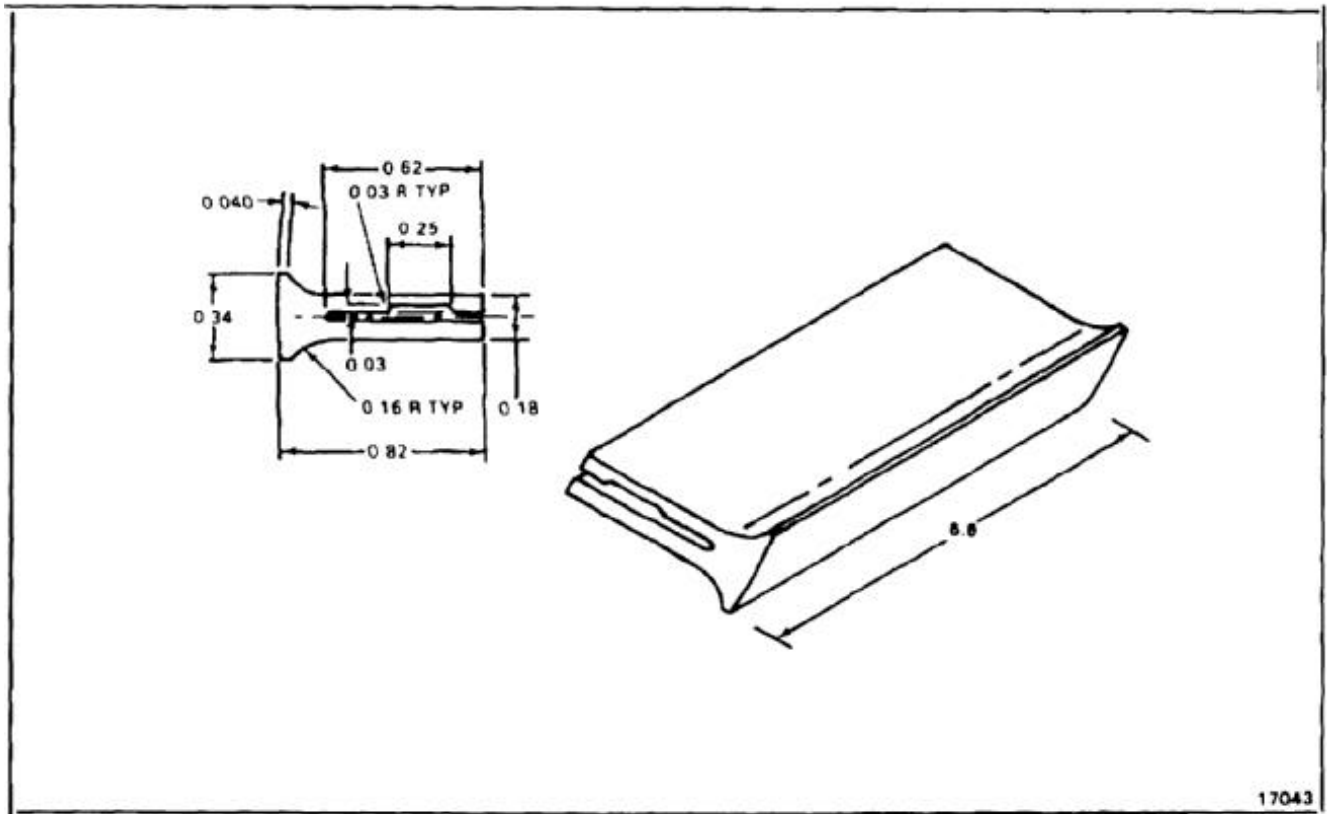

END OF TASK

NOTES:

1. FABRICATE FROM ALUMINUM EXTRUSION
0.063 THICK 2024-T 3511 PER QQ-A-200/3.
2. ALL DIMENSIONS IN INCHES.
3. STOCK AND 10134-0602 X 22.00 (0.063)
THICK.
4. FINISH AS REQUIRED.

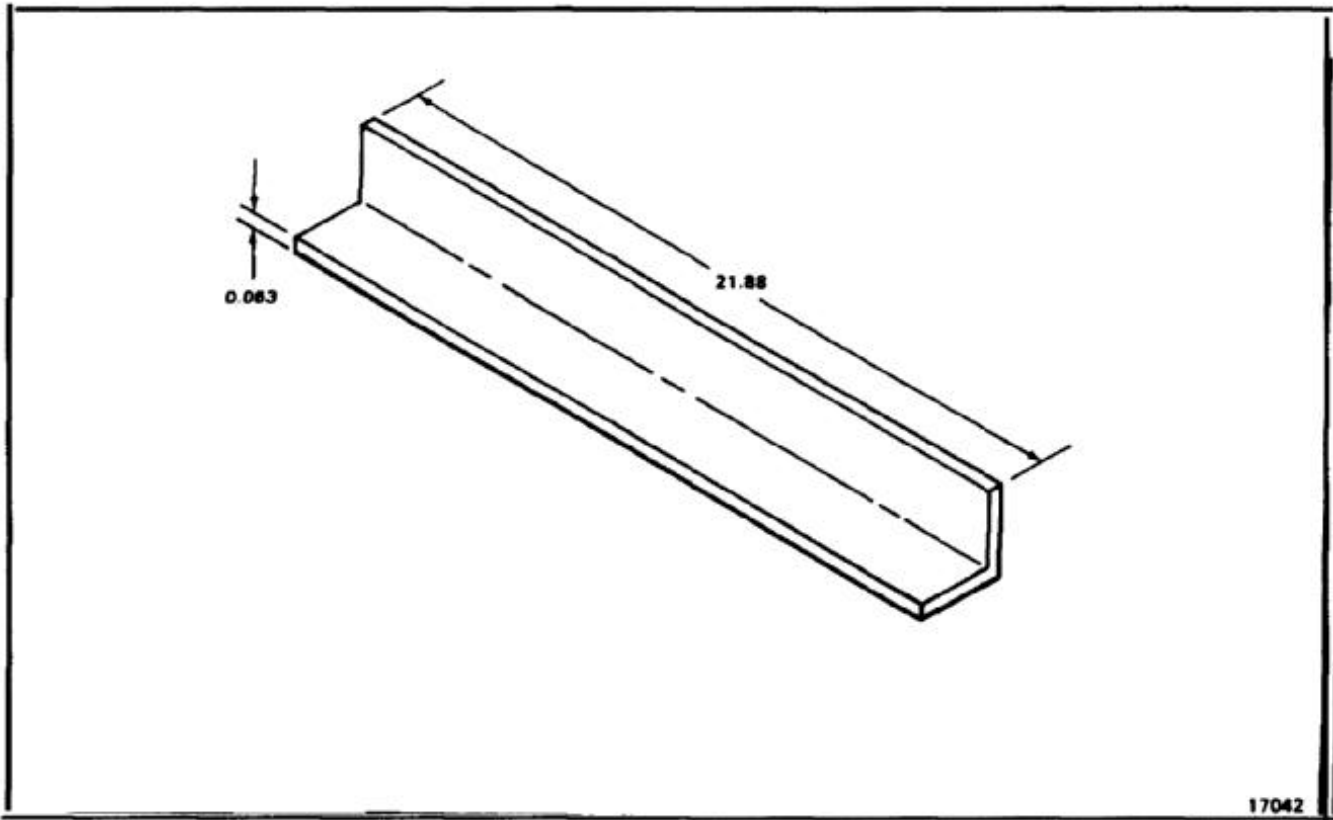

END OF TASK

E-190

NOTES:

1. FABRICATE FROM CLAD ALUMINUM ALLOY 7075-T6 PER QQ-A-25015.
2. ALL DIMENSIONS IN INCHES.
3. STOCK SIZE 0.100 X 1.800 X 19.8.
4. USE ORIGINAL FOR TEMPLATE WHEN MAKING REPLACEMENT.
5. FINISH AS REQUIRED.

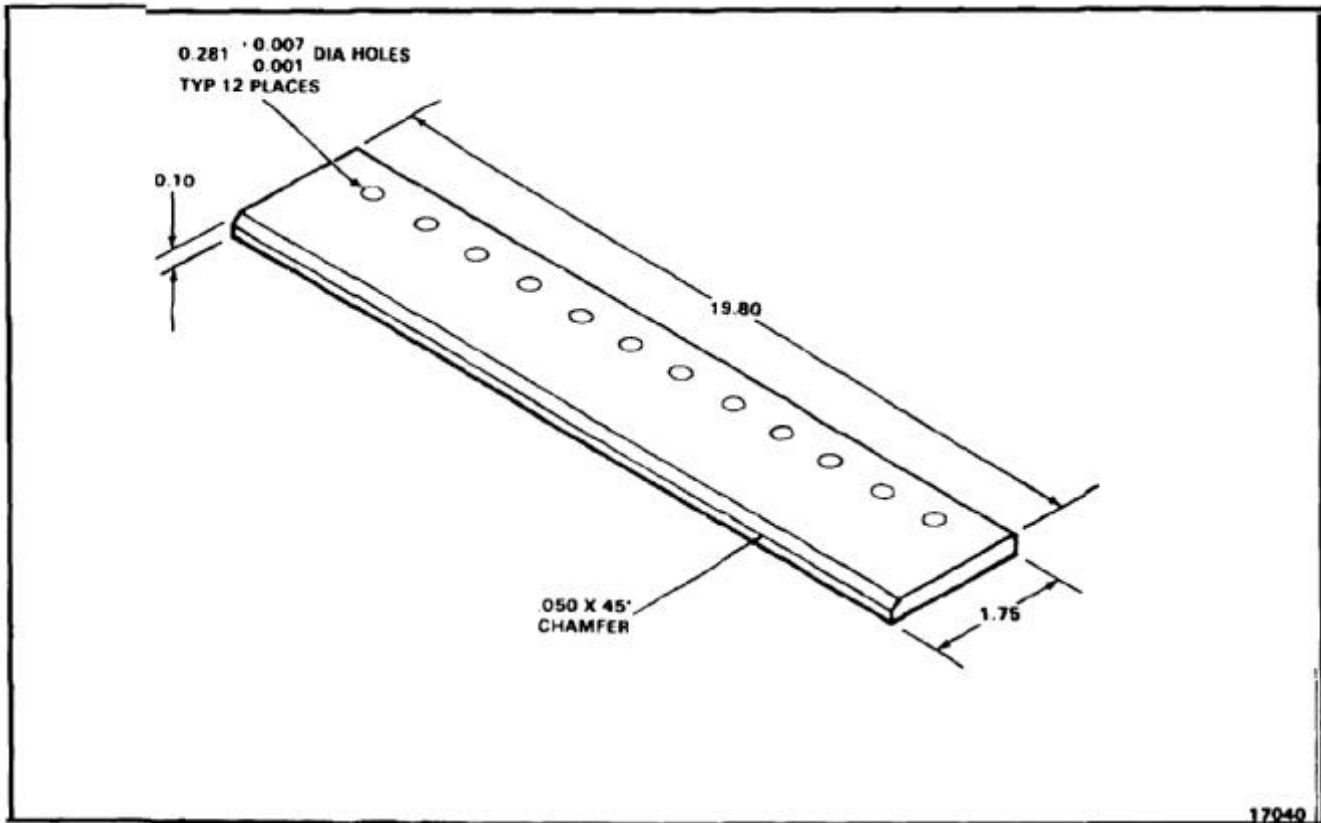

END OF TASK

NOTES:

1. FABRICATE FROM NSN 5310-00-915-7985 GANG CHANNEL.
2. ALL DIMENSIONS IN INCHES.
3. NUTS ARE 0.1900-32 UNJ-3B THREAD IN ALUMINUM CHANNEL.
4. CUT LENGTH SAME AS REPLACEMENT PART.

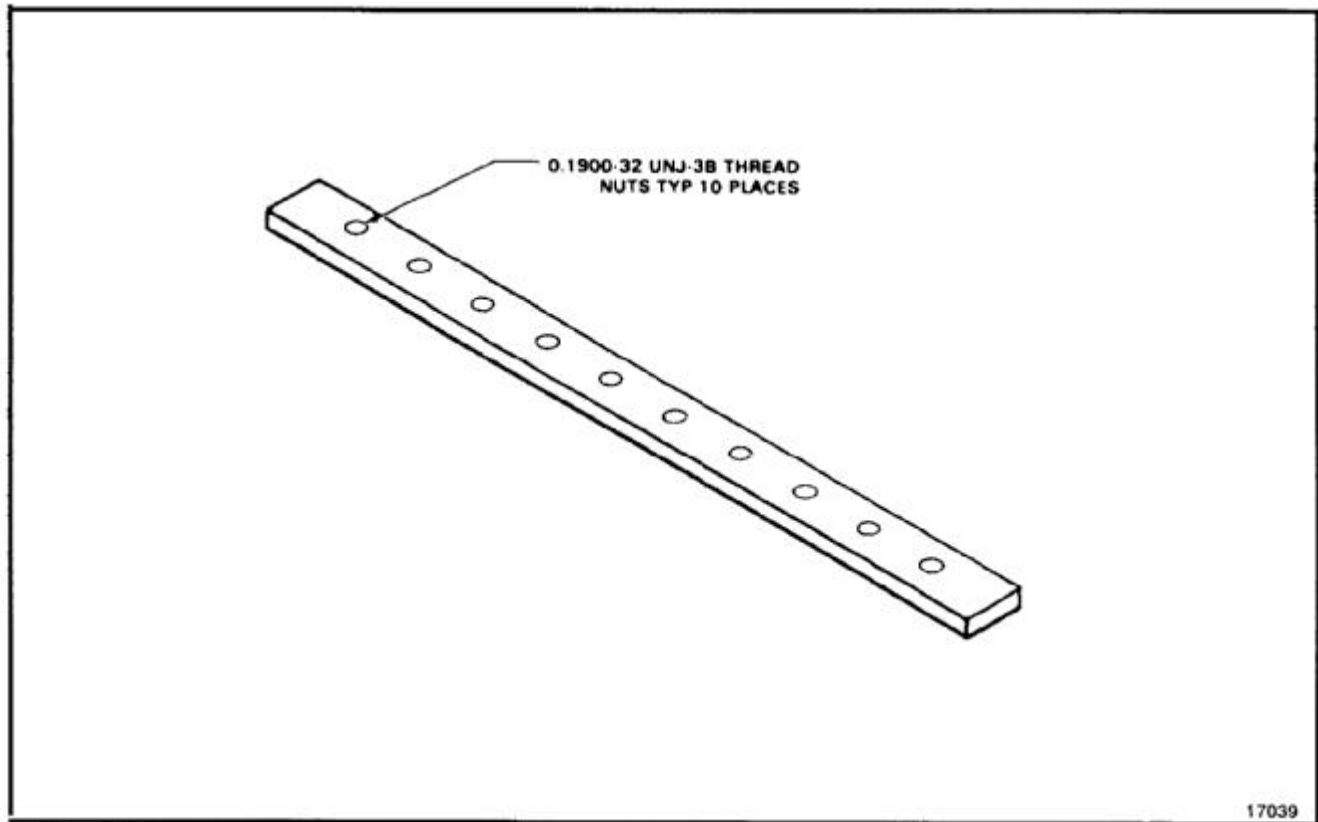

END OF TASK

NOTES:

1. FABRICATE FROM NSN 5310-00-915-7985 GANG CHANNEL.
2. ALL DIMENSIONS IN INCHES.
3. NUTS ARE 0.1900-32 UNJ-3B THREAD IN ALUMINUM CHANNEL.
4. CUT LENGTH SAME AS REPLACEMENT PART.

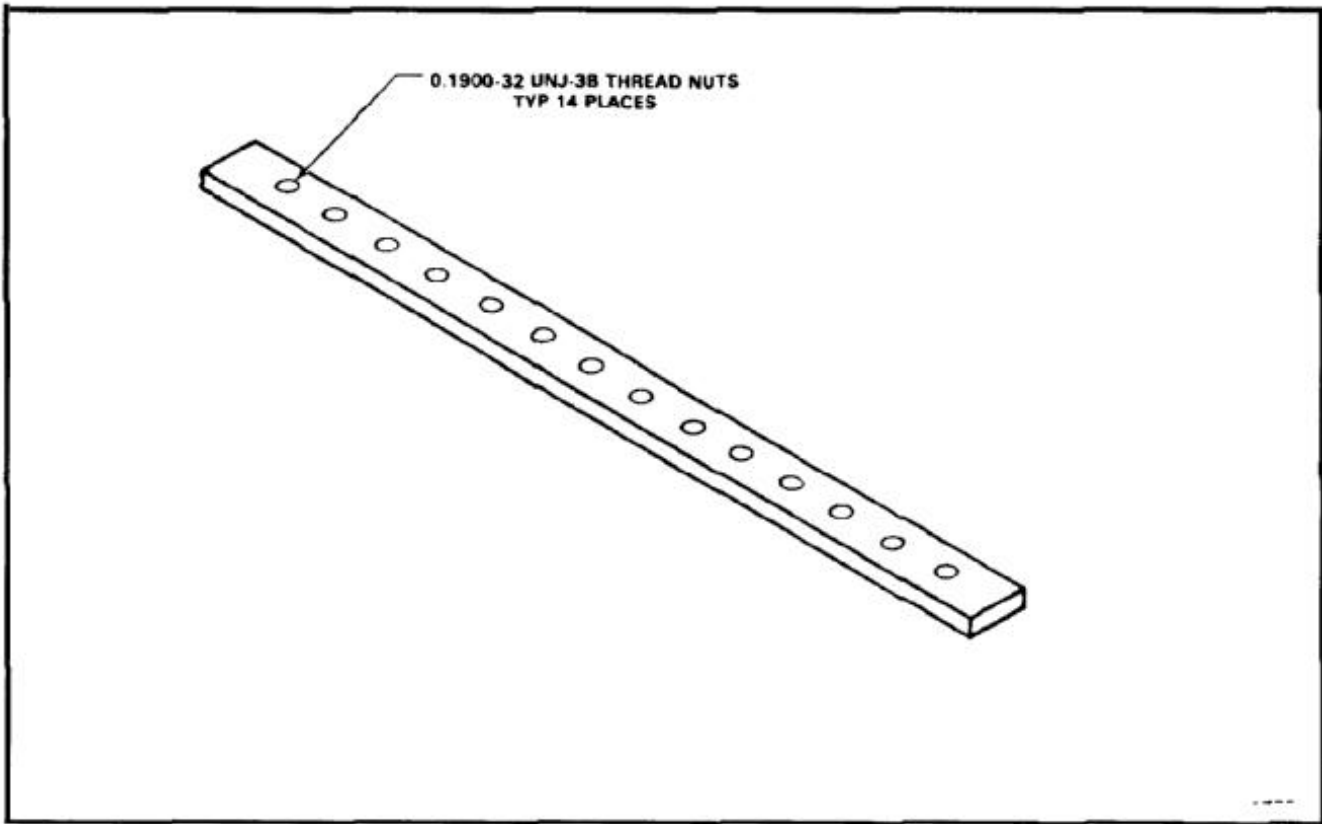

END OF TASK

NOTES:

1. FABRICATE FROM TUBULAR WEBBING PER MIL-W-5625 COLOR MED. GRAY.
2. ALL DIMENSIONS IN INCHES.
3. STOCK SIZE 0.070-0.10 X 0.50 LENGTH 6 INCHES.
4. SEAR FASTENER HOLES AND STRAP ENDS TO PREVENT FRAYING.

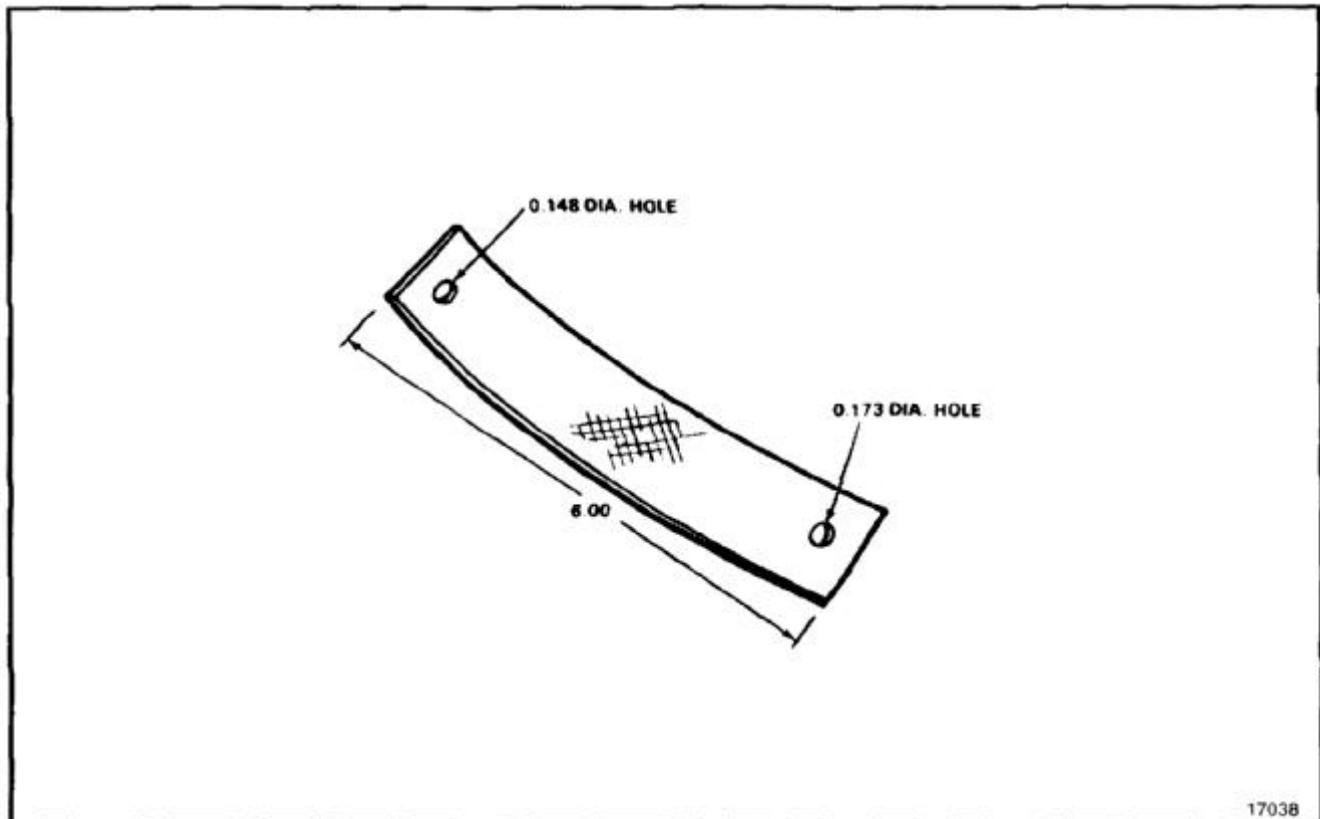

17038

END OF TASK

NOTES:

1. FABRICATE FROM CRESCENT CABLE PER MIL-W-83420 TYPE I, COMPOSITION B.
2. ALL DIMENSIONS IN INCHES.
3. CABLE STOCK 1/16 X 7 X 7 LENGTH 6.5.



17037

END OF TASK

E-196

NOTES:

1. FABRICATE FROM 4002-10W CAMLOCK FASTENER.
2. ALL DIMENSIONS IN INCHES.
3. FINISH AS REQUIRED.

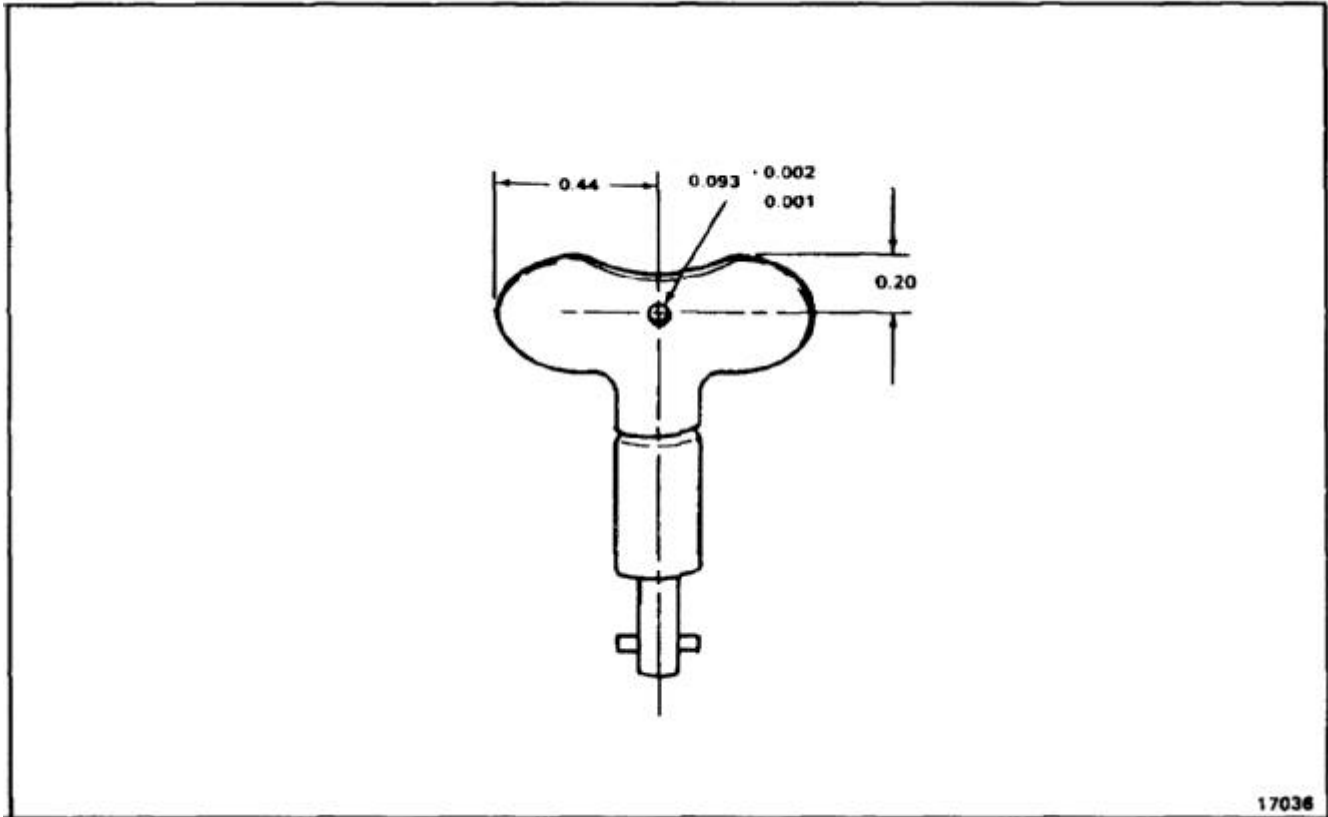

END OF TASK

NOTES:

1. FABRICATE FROM ALUMINUM ALLOY BARE SHT 7075 PER QQ-A-250/12.
2. ALL DIMENSIONS IN INCHES.
3. BRACKET STOCK SIZE .050 X 3.6 X 1.6.
4. USE ORIGINAL FOR TEMPLATE WHEN MAKING REPLACEMENT.
5. HEAT TREAT TO -T6 CONDITION PER BAC 5602.
6. FINISH AS REQUIRED.

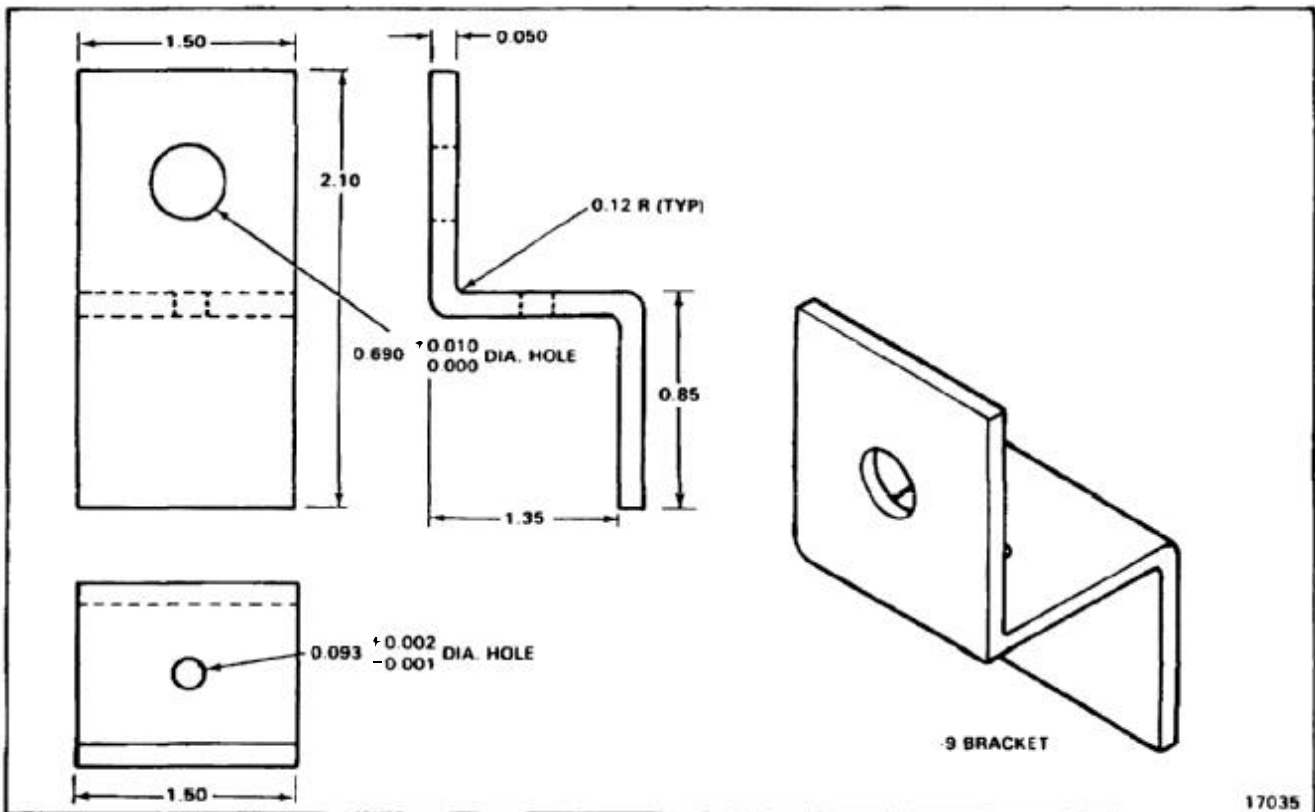

END OF TASK

NOTES:

1. FABRICATE FROM 4130 STEEL.
2. ALL DIMENSIONS IN INCHES.
3. BREAK SHARP EDGES.

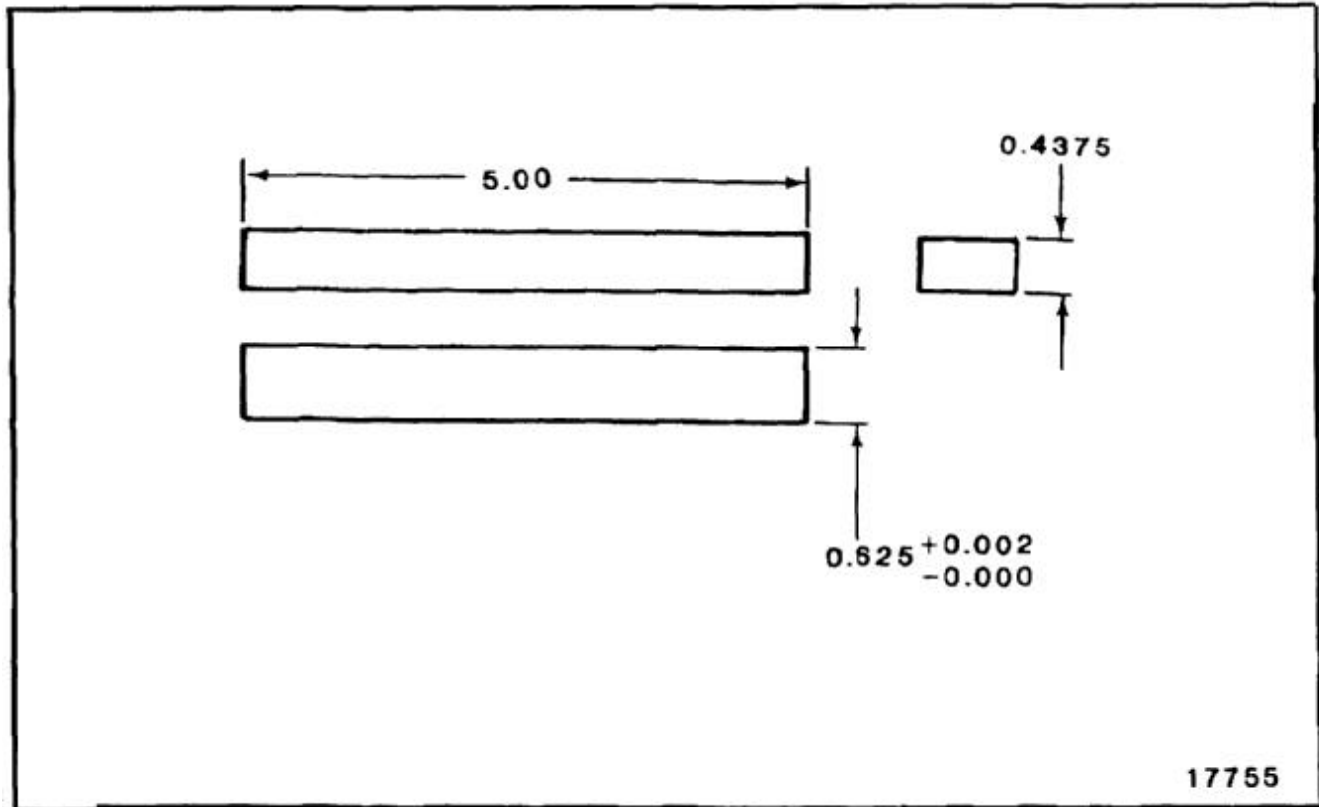

END OF TASK

NOTES:

1. FABRICATE FROM ALUMINUM EXTRUSION
0.063 THICK 2024-T3511 PER QQ-A-200/3.
2. ALL DIMENSIONS IN INCHES.
3. STOCK AND 10133-0601 EXTRUSION 0.063
THICK.
4. FINISH AS REQUIRED.

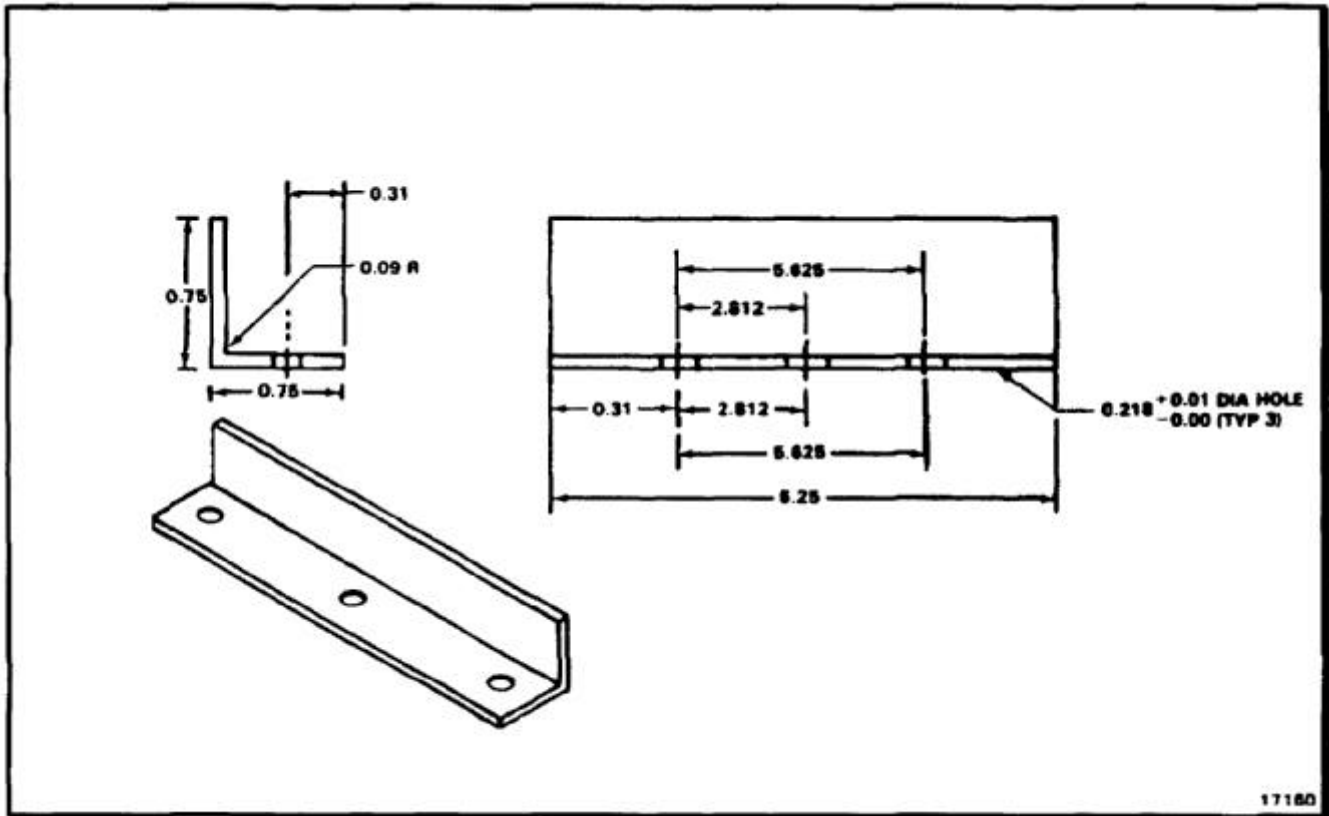

END OF TASK

NOTES:

1. FABRICATE FROM ALUMINUM CLAD ALLOY 2024-T3 PER QQ-A-250/5.
2. ALL DIMENSIONS IN INCHES.
3. STOCK SIZE 0.050 X 3.2 X 5.3.
4. USE ORIGINAL PART TO LOCATE HOLES.
5. FINISH AS REQUIRED.

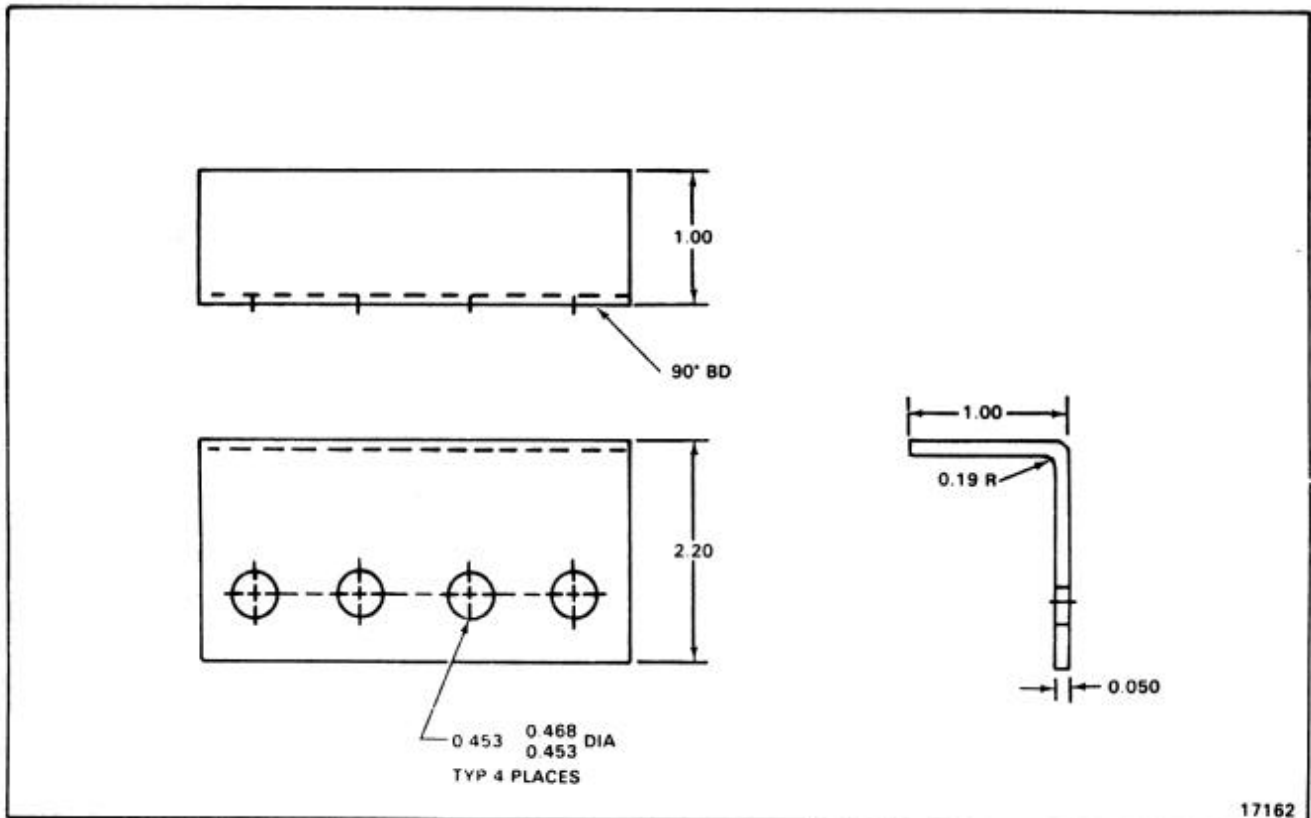

END OF TASK

NOTES:

1. FABRICATE FROM ALUMINUM EXTRUSION 2024-T3511 PER QQ-A-200/3.
2. ALL DIMENSIONS IN INCHES.
3. STOCK SIZE AND 10133-1001 X 23.8.
4. USE OLD PART AS TEMPLATE WHEN MAKING REPLACEMENT.
5. FINISH AS REQUIRED.

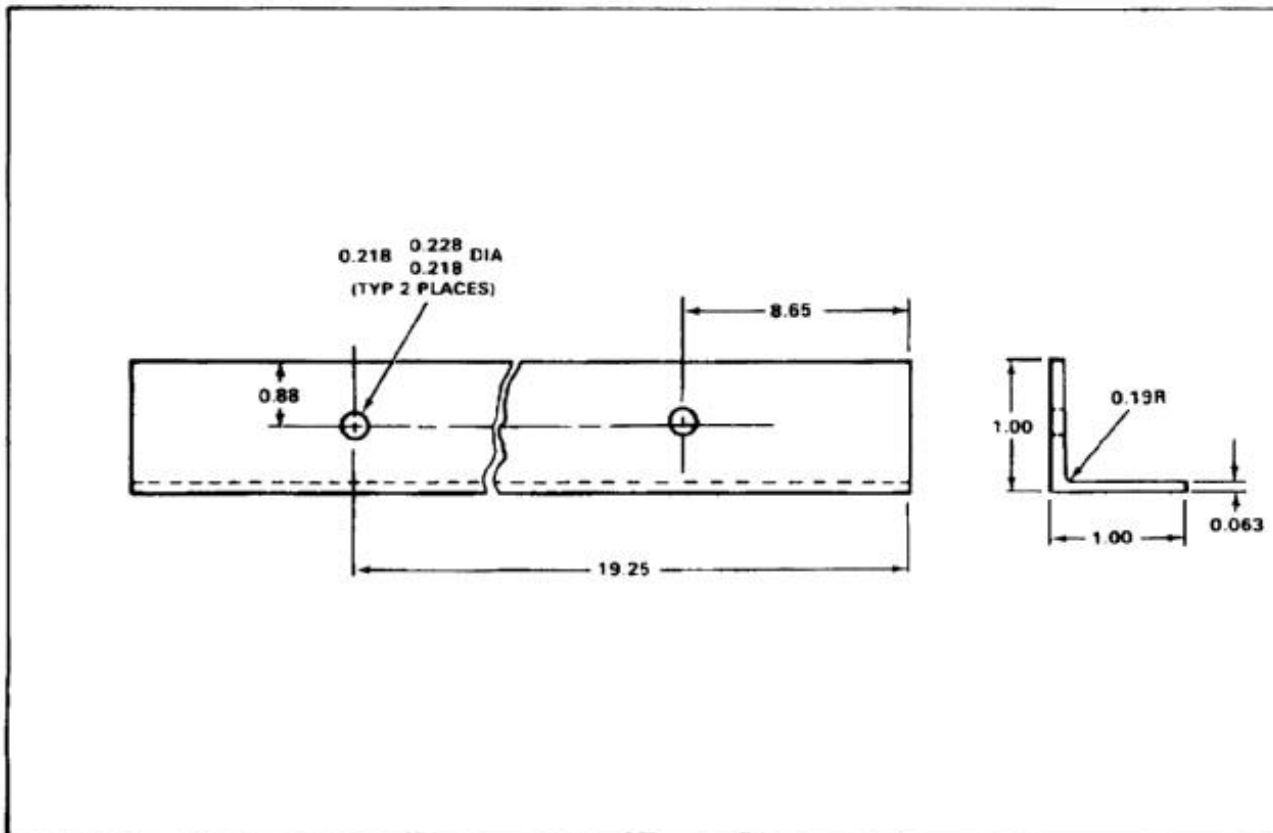

END OF TASK

E-202

NOTES:

1. MAKE FROM SILICON RUBBER MIL-R-5847 CLASS III, GRADE 50, COLOR BLACK.
2. ALL DIMENSIONS IN INCHES.
3. STOCK SHAPE NUMBER VS80555-1 X 22.8.
4. CUT LENGTH TO FIT.

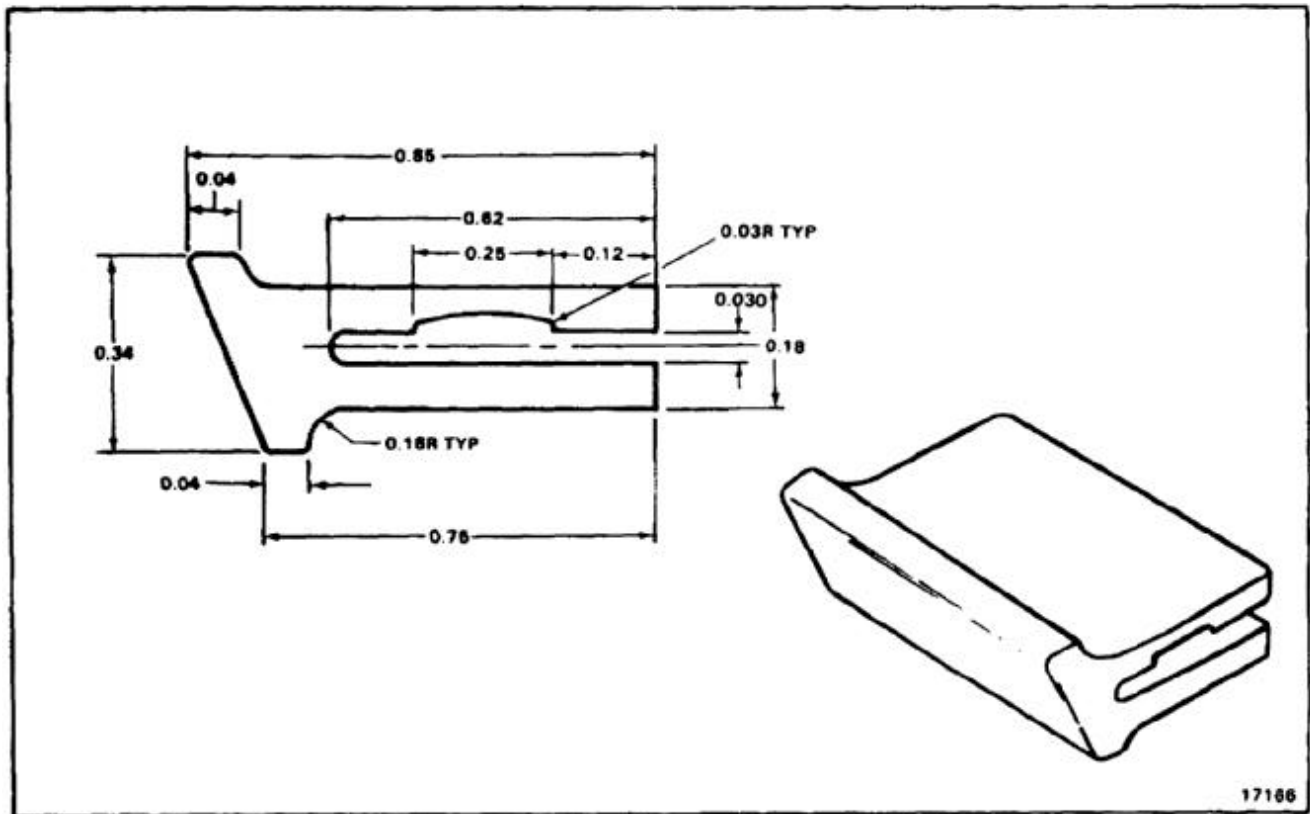

END OF TASK

NOTES:

1. MAKE FROM SILICON RUBBER MIL-R-5847 CLASS III, GRADE 50, COLOR BLACK.
2. ALL DIMENSIONS IN INCHES.
3. STOCK SHAPE NUMBER VS80546-1 X 30.0.
4. CUT LENGTH TO FIT.

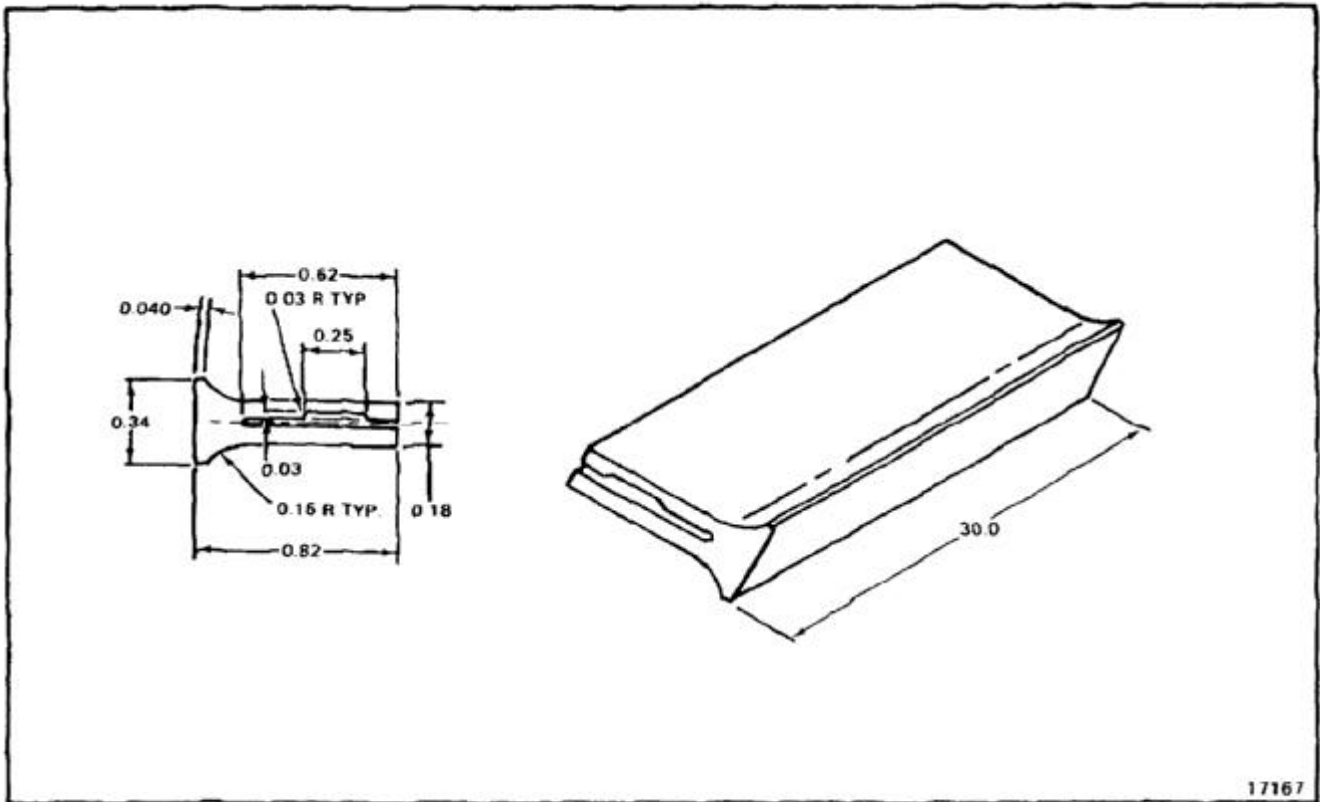

END OF TASK

NOTES:

1. MAKE FROM WOVEN NYLON WEBBING MIL-W-4088, TYPE I, COLOR CINDER GRAY.
2. ALL DIMENSIONS IN INCHES.
3. STOCK SIZE: 10.0 LONG X 5/8 WIDE.

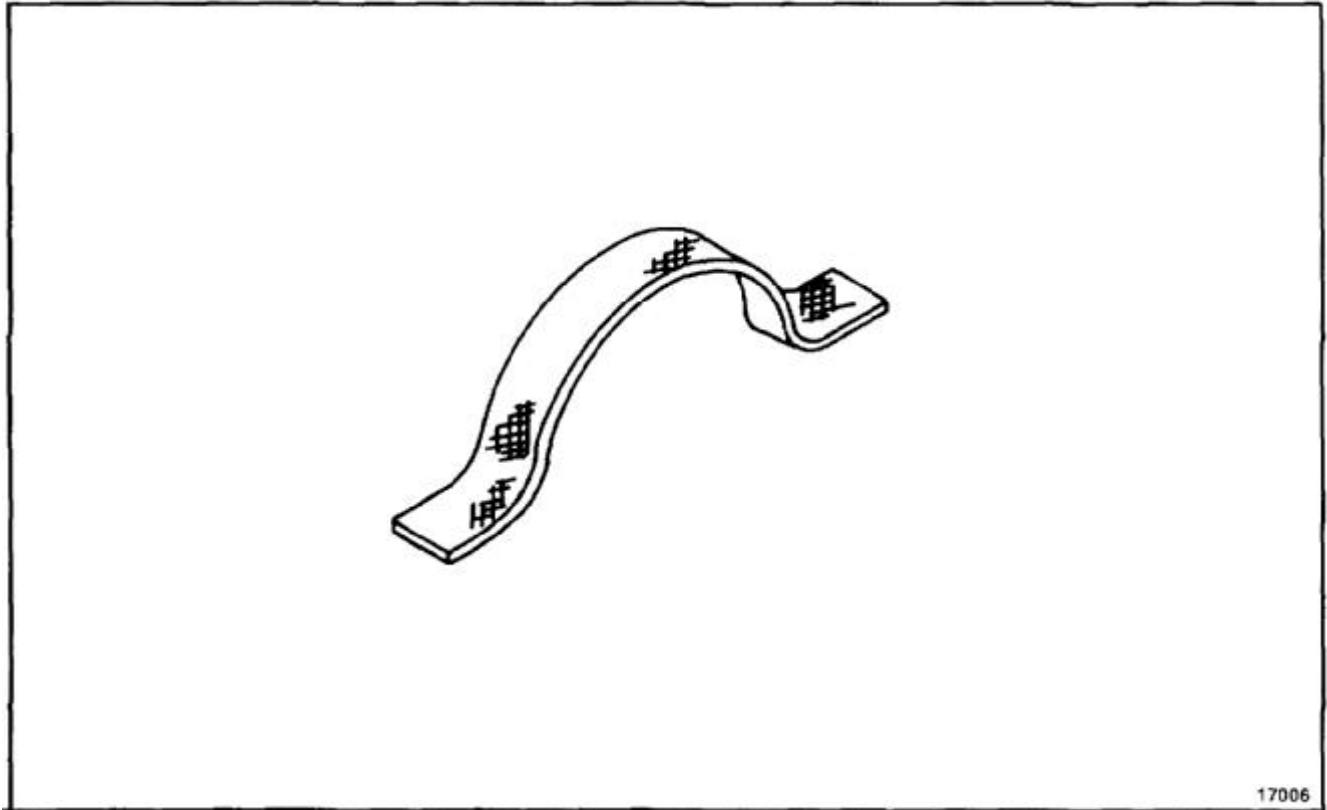

END OF TASK

NOTES:

1. FABRICATE FROM ALUMINUM ALLOY CLAD SHEET 7075-T6 PER QQ-A-250/5.
2. ALL DIMENSIONS IN INCHES.
3. STOCK SIZE 0.025 X 0.50 X 60.0.
4. PICK UP RIVET LOCATIONS FROM EXISTING HOLES IN DOOR.

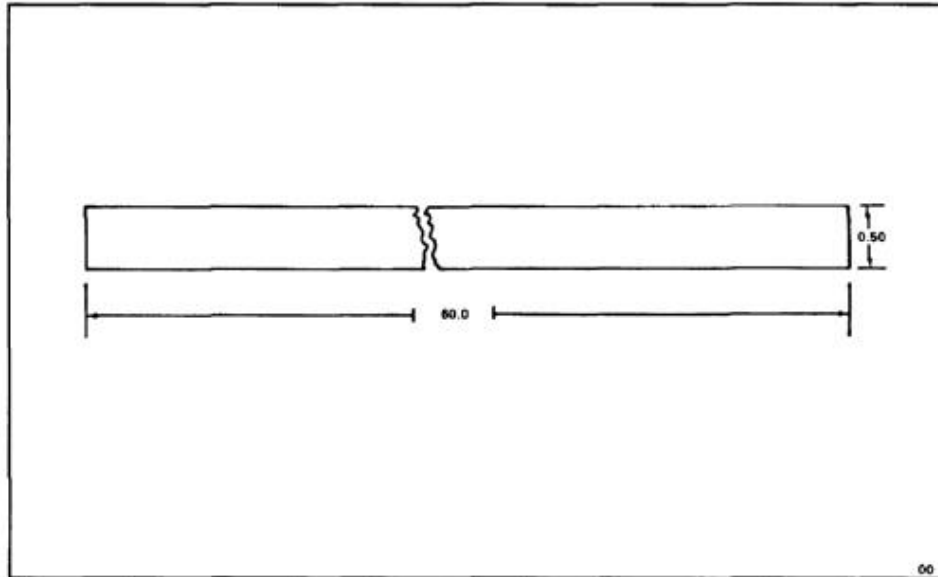

END OF TASK

NOTES:

1. FABRICATE FROM SILICON RUBBER SHEET
AMS 3195.
2. ALL DIMENSIONS IN INCHES.
3. STOCK SIZE 0.50 X 0.50 X 0.50.
4. TRIM TO FIT.

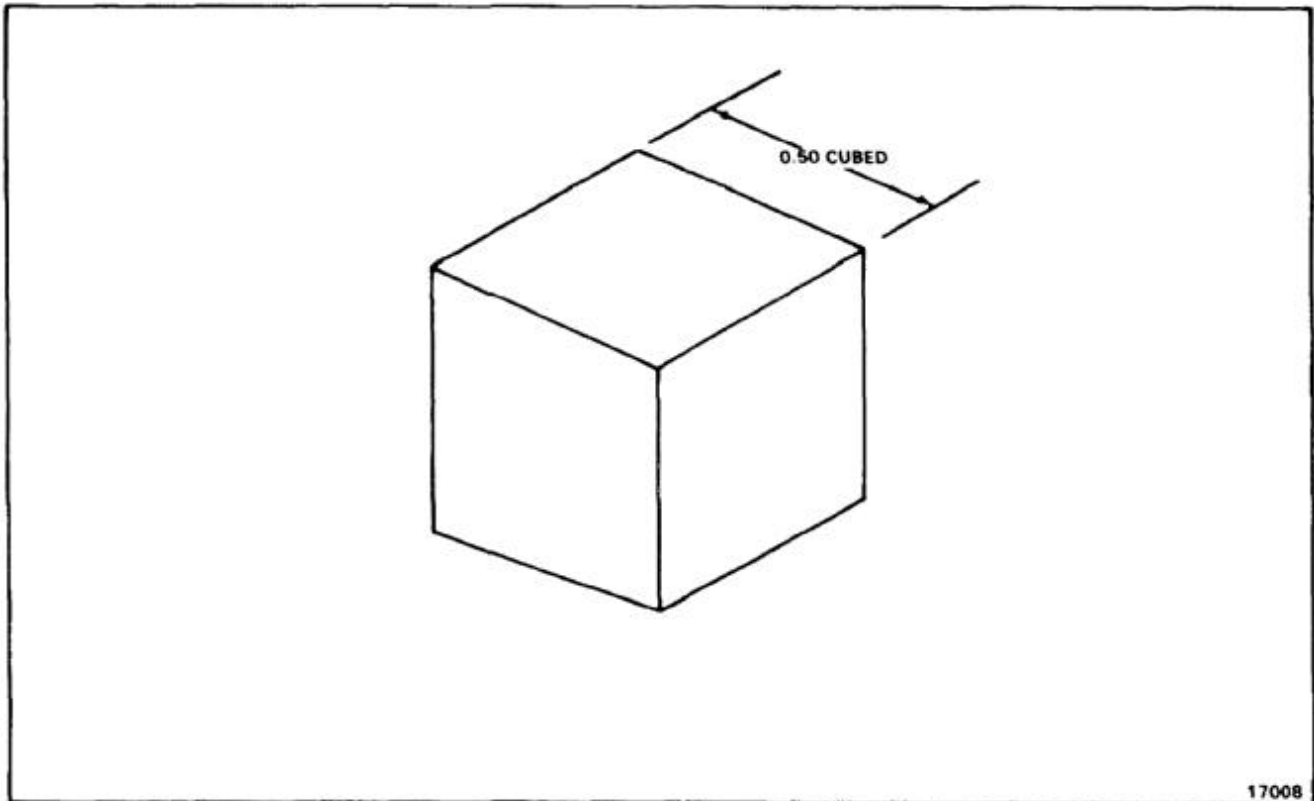

END OF TASK

NOTES:

1. FABRICATE FROM VS80574 NYLATRON GS. THE POLYMER CORP. OF PA., READING, PA 19603 (IDENT. NO. 83616) OR NYLON PER MIL-P-46060 COLOR LIGHT TO DARK GREY.
2. ALL DIMENSIONS IN INCHES.
3. TOLERANCES:
 .XX 0.02
 .XXX 0.010
 UNLESS OTHERWISE SPECIFIED.
4. LATERAL HOLE LOCATION USE OLD BEARING PAD OR TRANSFER DRILL FROM AIRFRAME TO NEW PAD.
5. STOCK SIZE VS80574 X 7.1.
6. TRIM AS NECESSARY TO FIT.

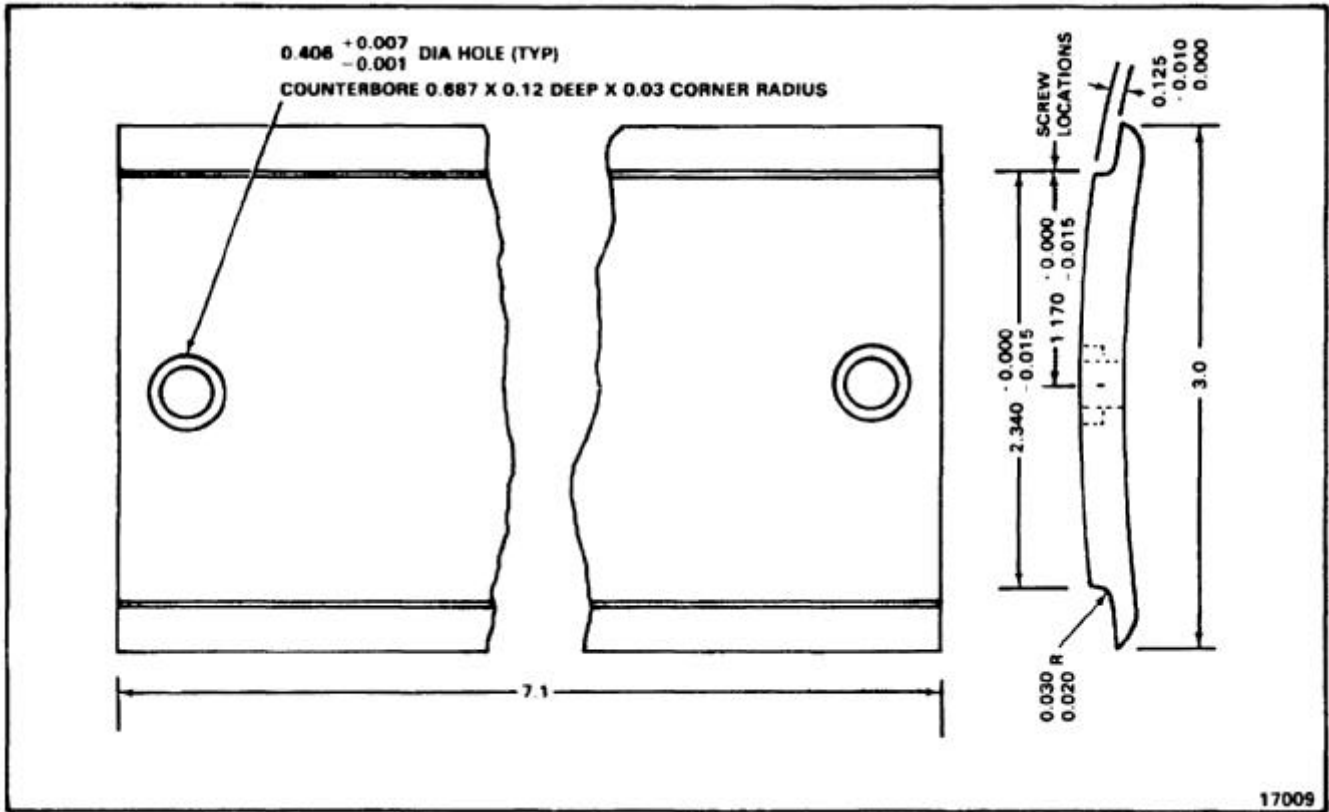

END OF TASK

NOTES:

1. FABRICATE FROM VS80574 NYLATRON GS. THE POLYMER CORP. OF PA., READING, PA 19603 (IDENT NO. 83616) OR NYLON PER MIL-P-46060 COLOR LIGHT TO DARK GREY.
2. ALL DIMENSIONS IN INCHES.
3. TOLERANCES:
 .XX± 0.02
 ±.XXX 0.010
 UNLESS OTHERWISE SPECIFIED.
4. FOR LATERAL HOLE LOCATION USE OLD BEARING PAD OR TRANSFER DRILL FROM AIRFRAME TO NEW PAD.
5. STOCK SIZE VS80574 X 15.0
6. TRIM AS NECESSARY TO FIT.

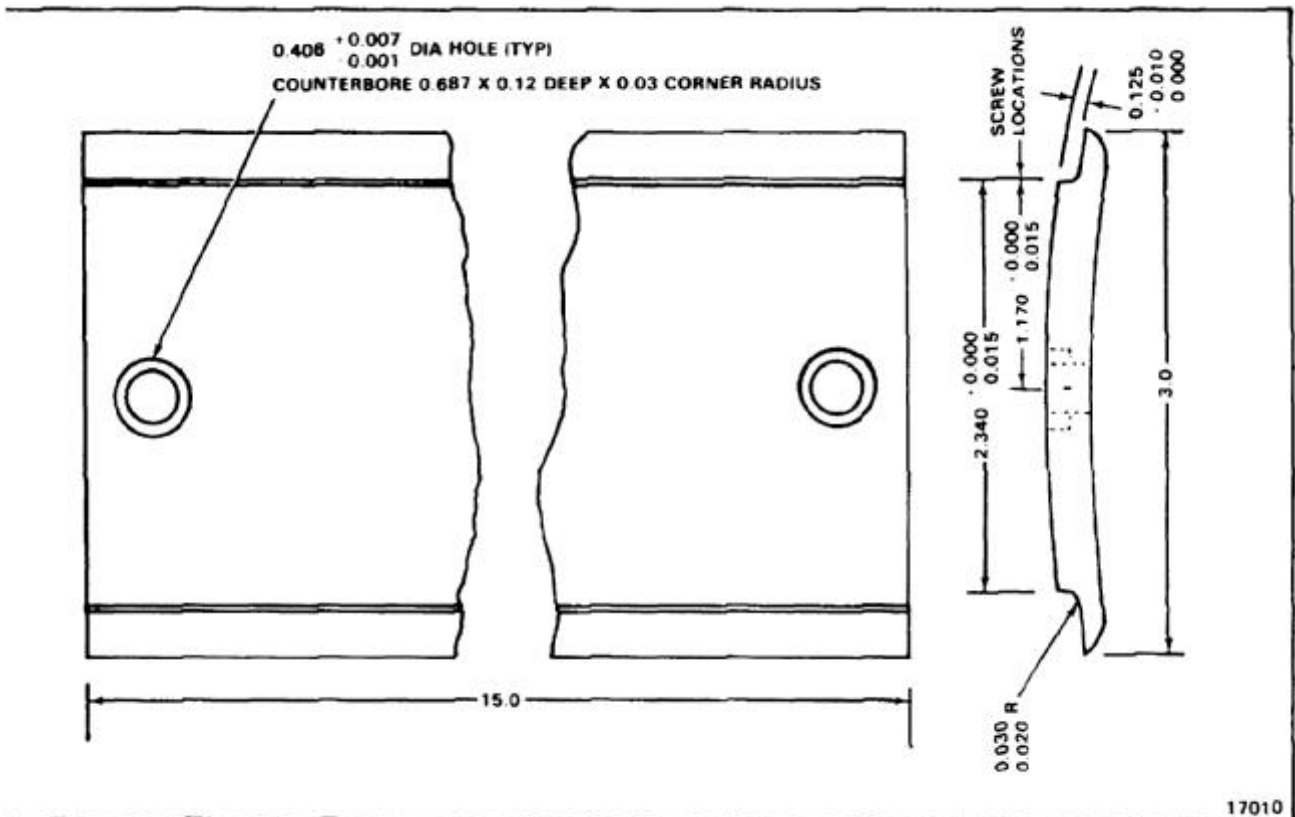

END OF TASK

NOTES:

1. FABRICATE FROM VS80574 NYLATRON GS. THE POLYMER CORP. OF PA., READING, PA 19603 (IDENT NO. 83616) OR NYLON PER MIL-P-46060 COLOR LIGHT TO DARK GREY.
2. ALL DIMENSIONS IN INCHES.
3. TOLERANCES:
 .XX± 0.02
 ±.XXX 0.010
 UNLESS OTHERWISE SPECIFIED.
4. FOR LATERAL HOLE LOCATION USE OLD BEARING PAD OR TRANSFER DRILL FROM AIRFRAME TO NEW PAD.
5. STOCK SIZE VS80574 X 15.0
6. TRIM AS NECESSARY TO FIT.

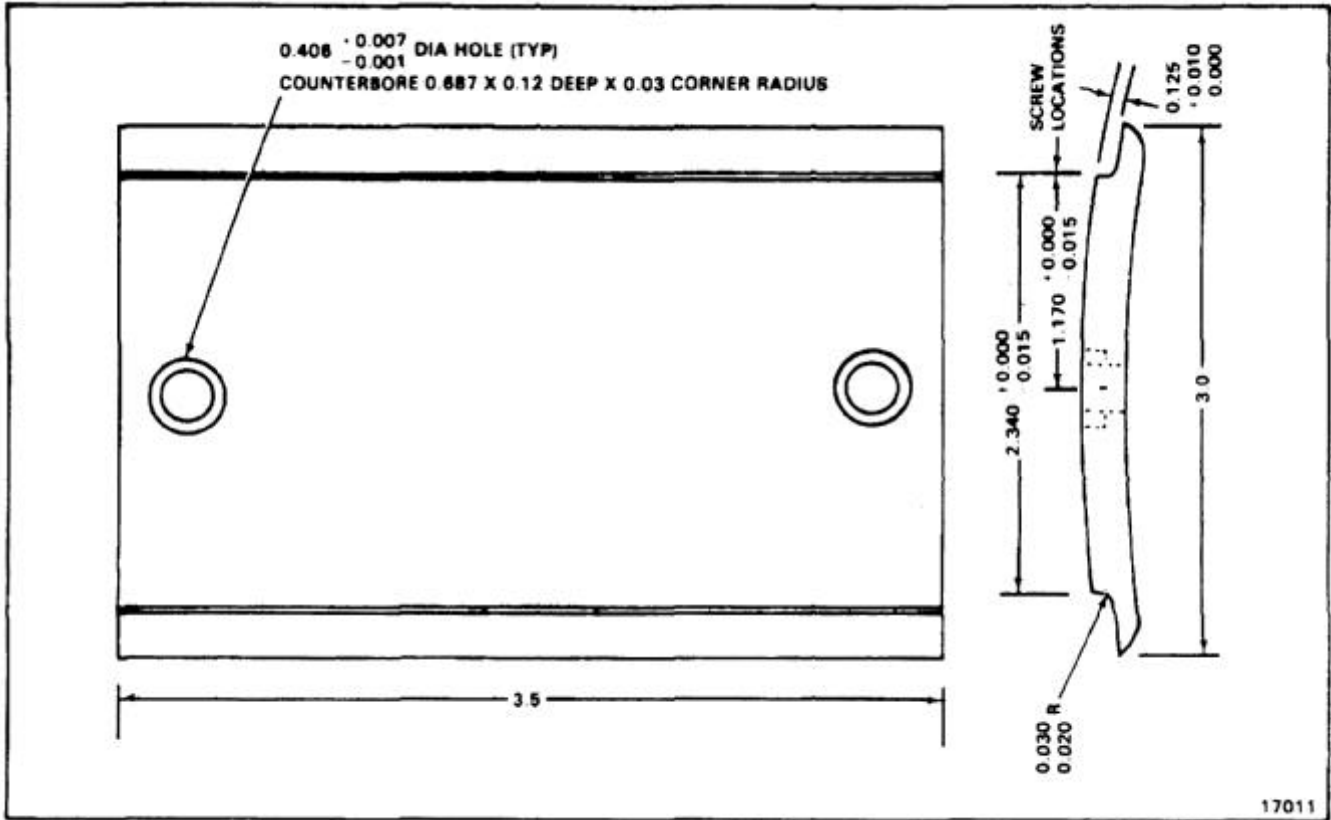

END OF TASK

NOTES:

1. FABRICATE FROM BUNA-N-RUBBER,
NSN 9320-01-317-4700.
2. ALL DIMENSIONS IN INCHES.
3. STOCK SIZE 1.5 THICK X 2.0 X 2.0.

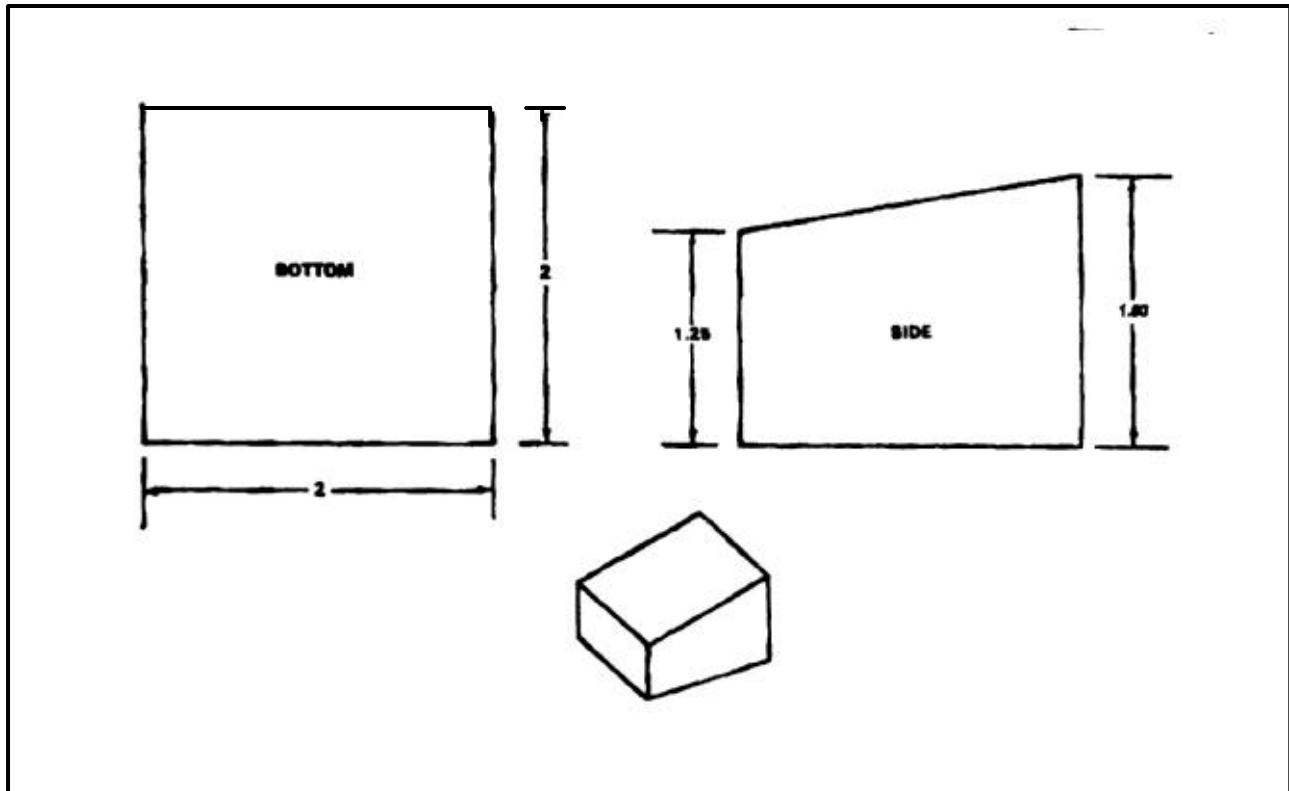

END OF TASK

NOTES:

1. FABRICATE FROM NYLON WEBBING MIL-W-4088, TYPE XXI.
2. ALL DIMENSIONS IN INCHES.
3. STOCK SIZED 0.065 X 1.25 X 3.25.
4. SHEAR ALL EDGES AND HOLES TO PREVENT FRAYING.

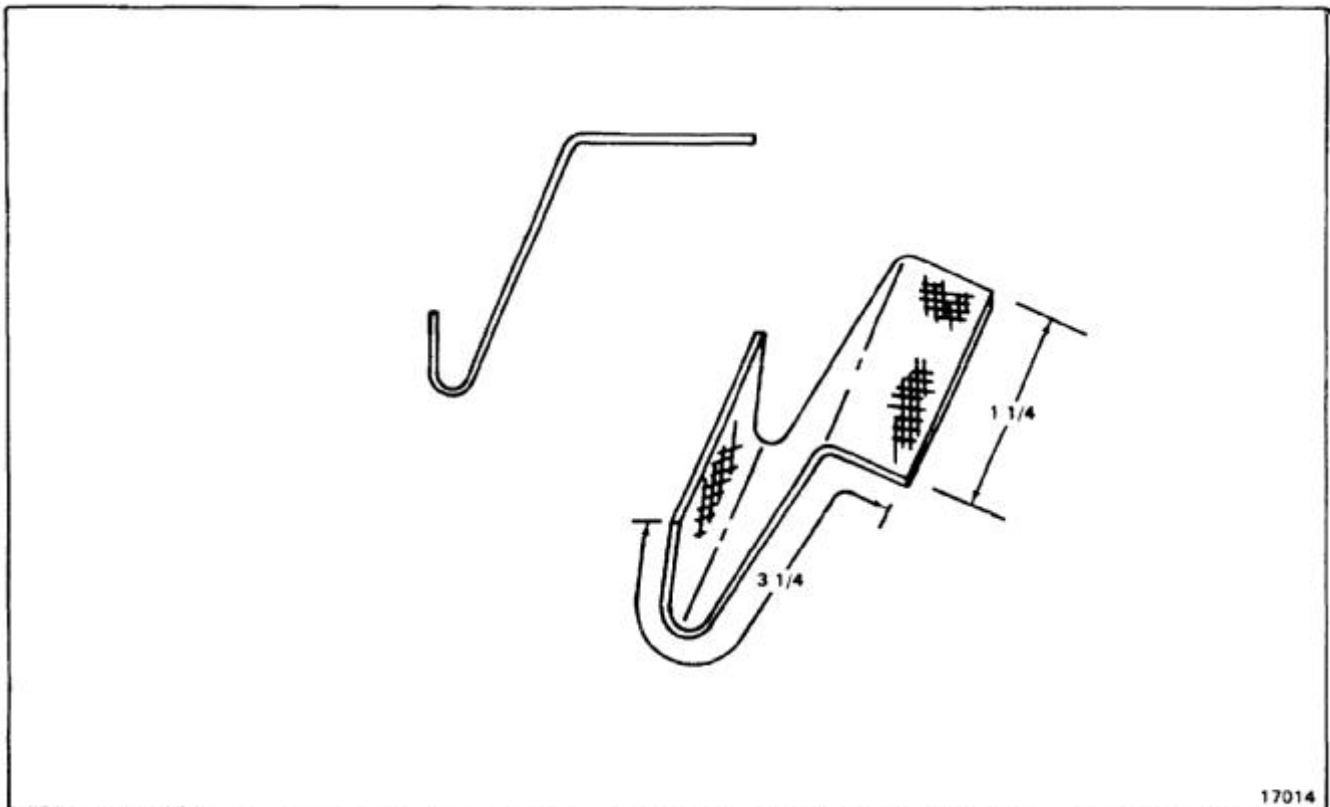

END OF TASK

E-212

NOTES:

1. FABRICATE FROM WOVEN NYLON WEBBING MIL-W-4088, TYPE XIV, COLOR CINDER GRAY TCA CABLE NO. 16522.
2. ALL DIMENSIONS IN INCHES.
3. STOCK SIZE 7.0 X 0.5.
4. SHEAR ALL CUT EDGES AND HOLES TO PREVENT FRAYING.

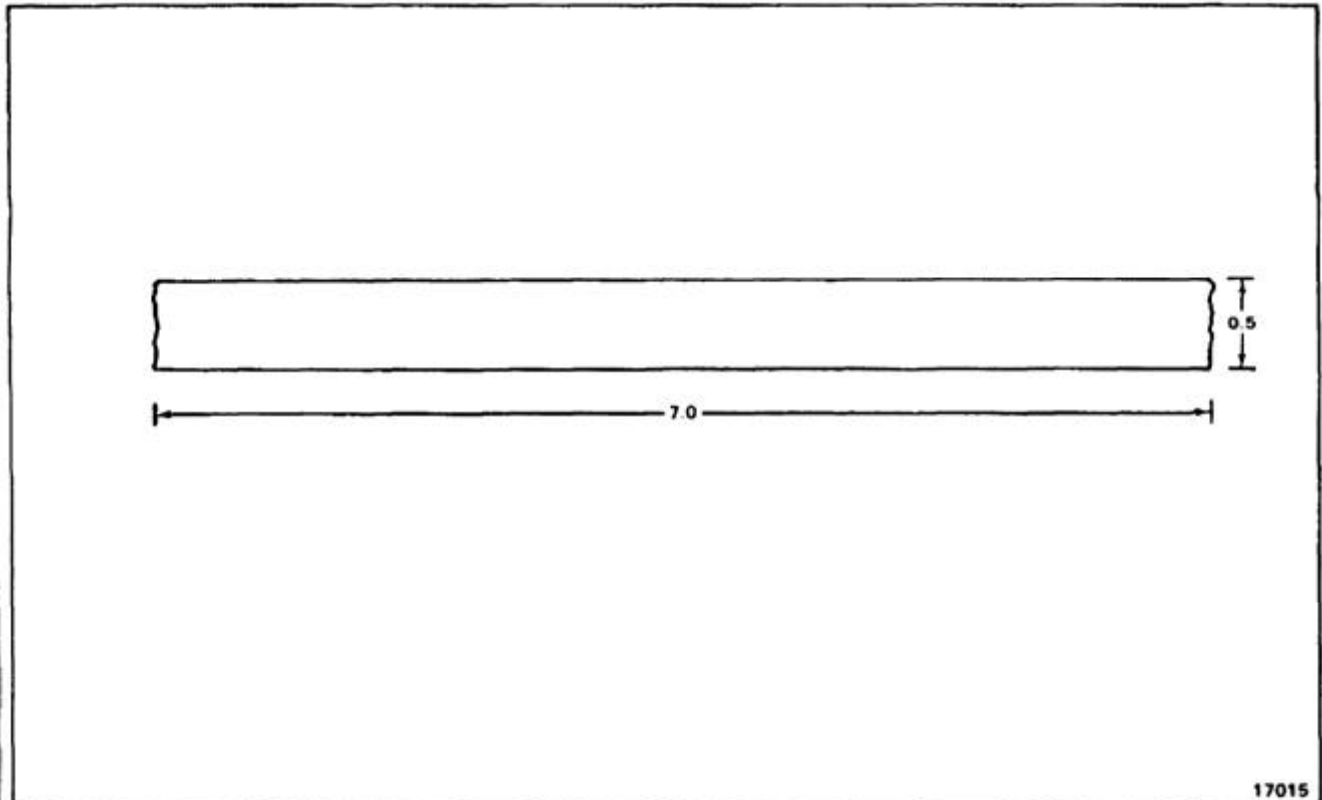

END OF TASK

NOTES:

1. FABRICATE FROM COTTON BASE LAMINATED PHENOLIC PER ML-P-18035 TYPE FBM.
2. ALL DIMENSIONS IN INCHES.
3. STOCK SIZE 0.125 X 1.0 X 2.0.
4. FINISH AS REQUIRED.

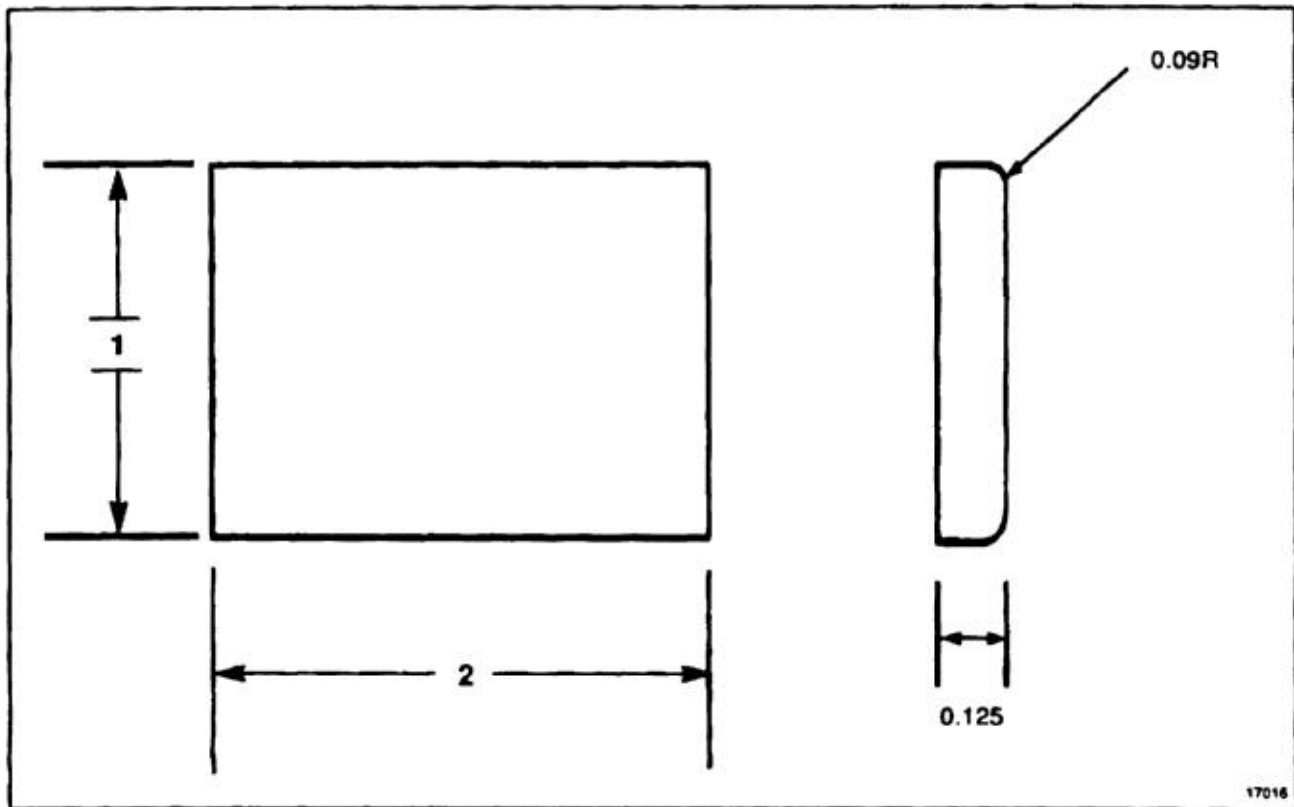

17016

END OF TASK

E-214

NOTES:

1. FABRICATE FROM ALUMINUM ALLOY CLAD
2024-T3 PER QQ-A-250/5,
NSN 9539-00-288-3662.
2. STOCK SIZE 0.040 X 12.9 X 15.3.
3. USE OLD SCREEN AS TEMPLATE.
4. FINISH AS REQUIRED.

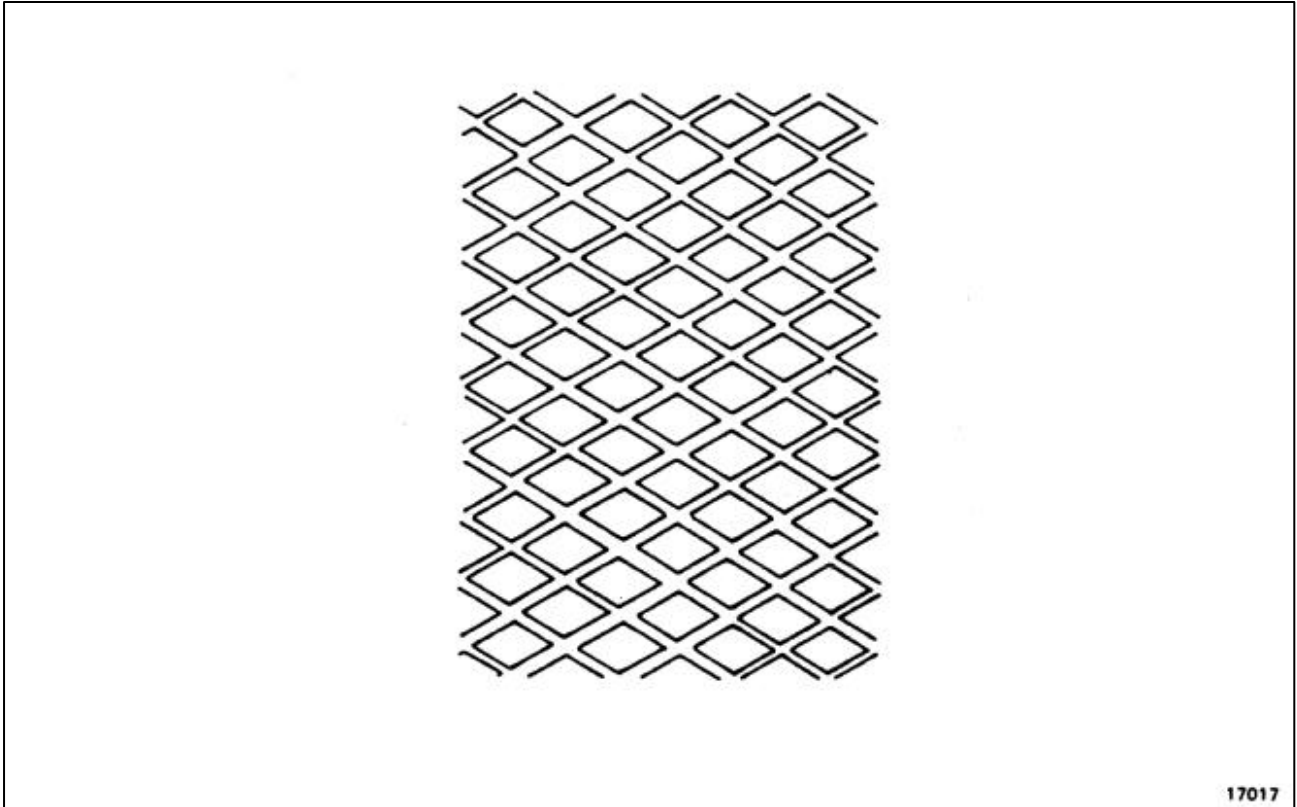

END OF TASK

NOTES:

1. FABRICATE FROM RT-1150 OR RT-1162
CONVOLEX TUBING - (POLYVINYLIDENE
FLUORIDE) RAYCHEM CORP, 300
CONSTITUTION DR., MENLO PARK, CA 94025.
2. ALL DIMENSIONS IN INCHES.
3. STOCK SIZE 1/2 INCH DIA
145S1652-19 = 11 INCH LG.
145S1652-21 = 30 INCH LG.
145S1652-20 = 142 INCH LG.

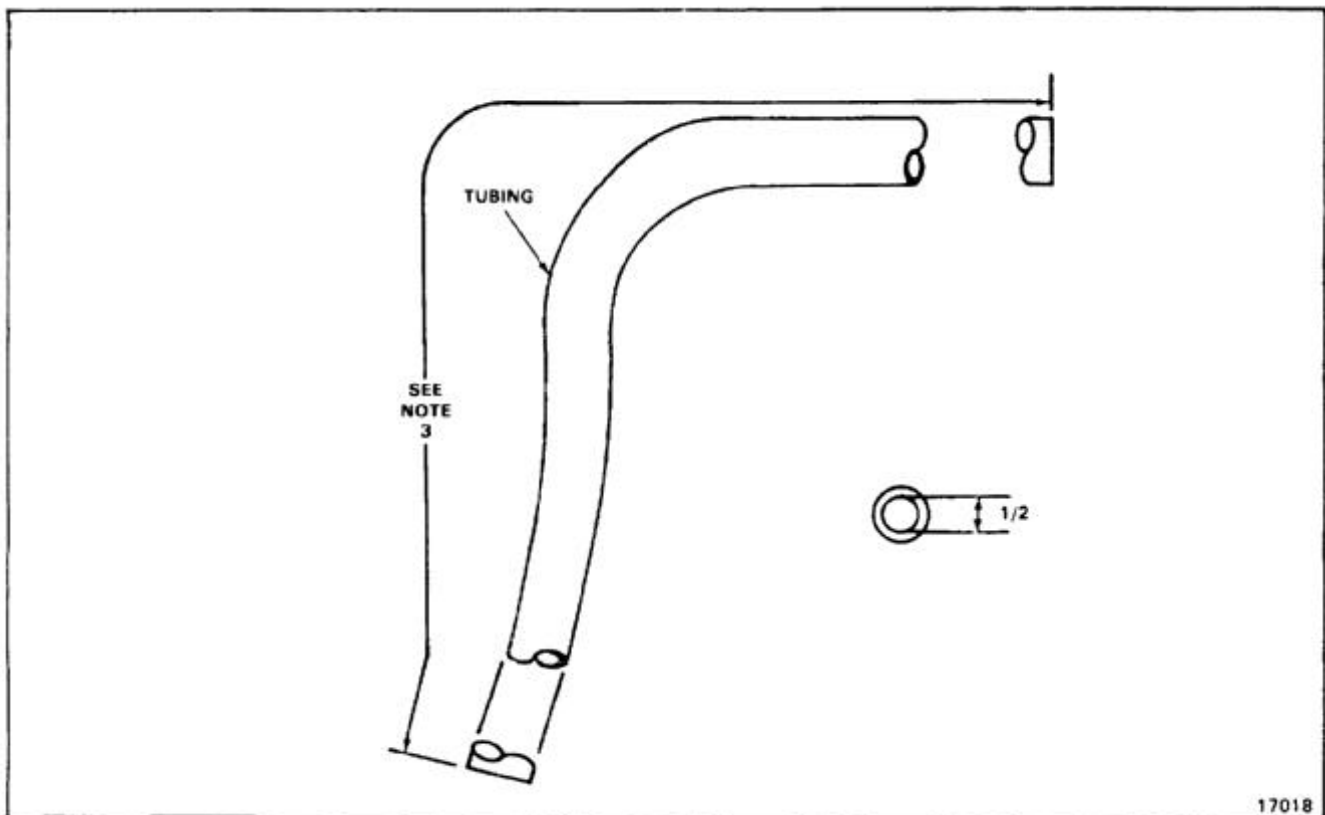

END OF TASK

E-216

NOTES:

1. FABRICATE FROM RT-1150 OR RT-1162
CONVOLEX TUBING - (POLYVINYLIDENE
FLUORIDE) RAYCHEM CORP, 300
CONSTITUTION DR., MENLO PARK, CA 94025.
2. ALL DIMENSIONS IN INCHES.
3. STOCK SIZE 5/8 DIA
145S1652-18 = 146.0 INCH LG.
145S1652-22 = 20.0 INCH LG.

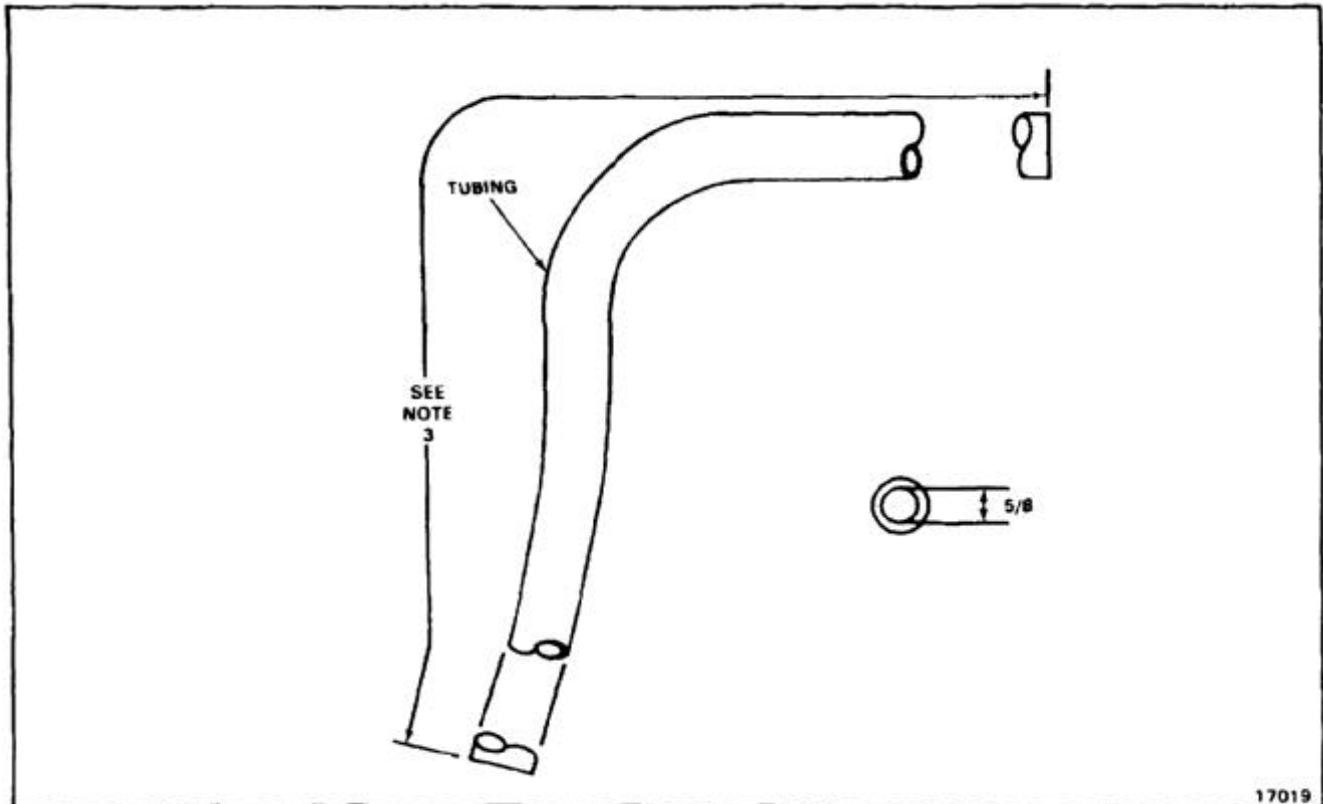

END OF TASK

NOTES:

1. FABRICATE FROM ALUMINUM ALLOY CLAD 2024-T3 PER QQ-A-250/5.
2. ALL DIMENSIONS IN INCHES.
3. STOCK SIZE 0.022 X 3.0 X 3.5.
4. USE OLD CLAMP AS TEMPLATE TO LOCATE HOLES.
5. FINISH AS REQUIRED.

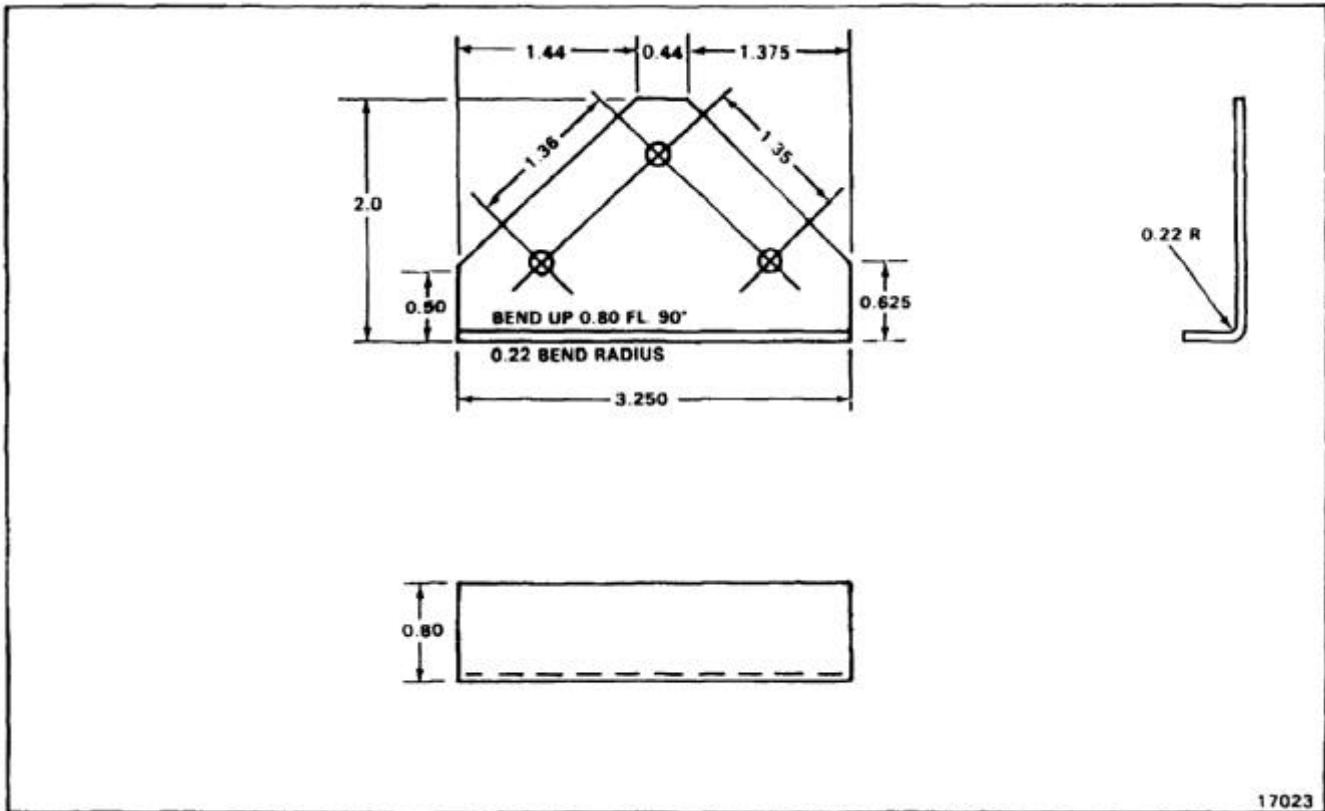

END OF TASK

NOTES:

1. FABRICATE FROM ALUMINUM ALLOY CLAD SHEET 2024-T3.
2. ALL DIMENSIONS IN INCHES.
3. STOCK SIZE 0.032 X 5.5 X 7.7.
4. USE ORIGINAL OR SIMILAR DOOR AS TEMPLATE.
5. COORDINATE RIVET HOLES WITH HINGE.
6. FINISH AS REQUIRED.

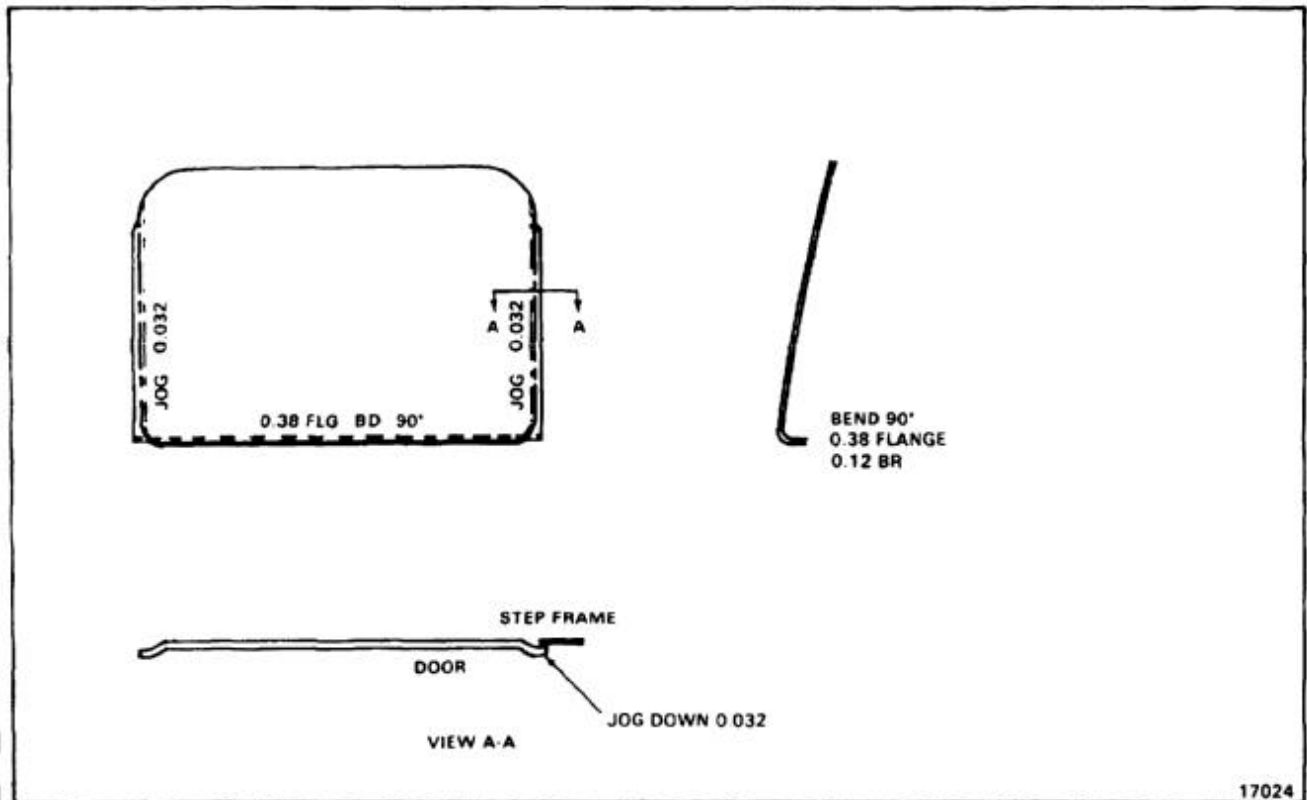

17024

END OF TASK

NOTES:

1. FABRICATE FROM ALUMINUM ALLOY CLAD SHEET 7075-TO.
2. ALL DIMENSIONS IN INCHES.
3. STOCK SIZE 0.063 X 2.3 X 7.8.
4. USE OLD SUPPORT FOR TEMPLATE WHEN MAKING NEW SUPPORT.
5. HEAT TREAT TO -T6 CONDITION PER BAC 5602.
6. COORDINATE RIVET HOLES WITH ATTACHING ASSEMBLY.
7. FINISH AS REQUIRED.

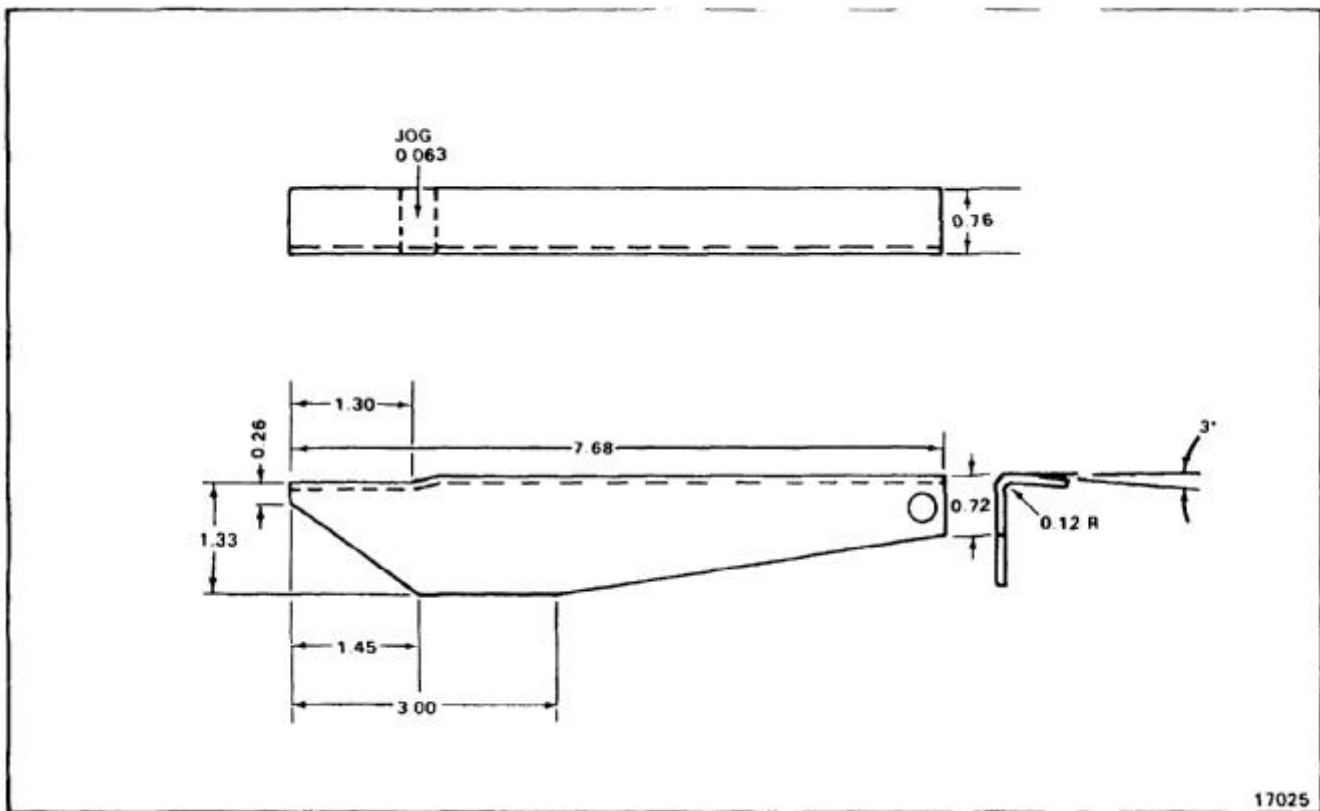

17025

END OF TASK

E-220

NOTES:

1. FABRICATE FROM ALUMINUM ALLOY CLAD SHEET 2024-T3.
2. ALL DIMENSIONS IN INCHES.
3. STOCK SIZE 0.040 X 2.0 X 4.5.
4. FINISH AS REQUIRED.

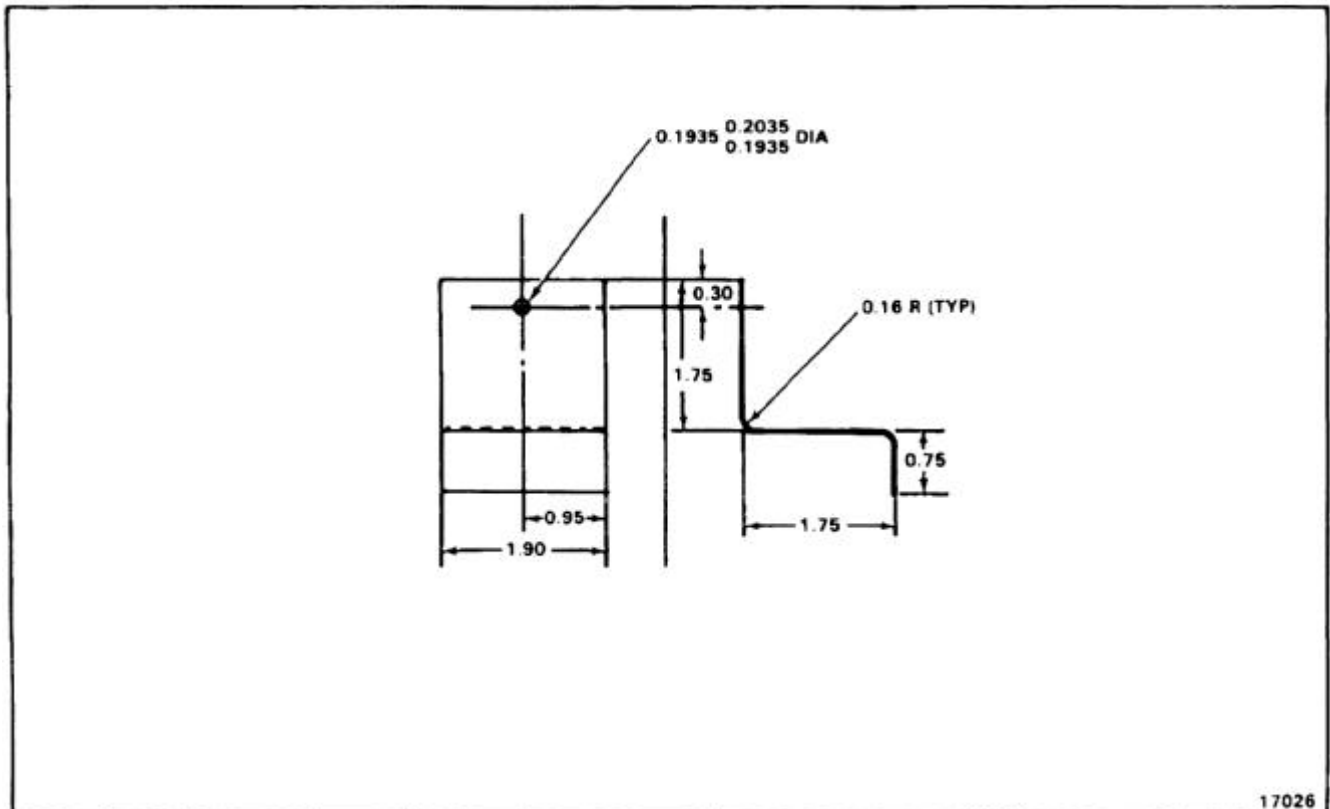

END OF TASK

NOTES:

1. MAKE FROM RUBBER EXTRUDED BAC1521-204 PER MIL-S-6855, TYPE II, GRADE 40.
2. ALL DIMENSIONS IN INCHES.
3. STOCK SIZE 38.0 LG.
4. CUT TO FIT.

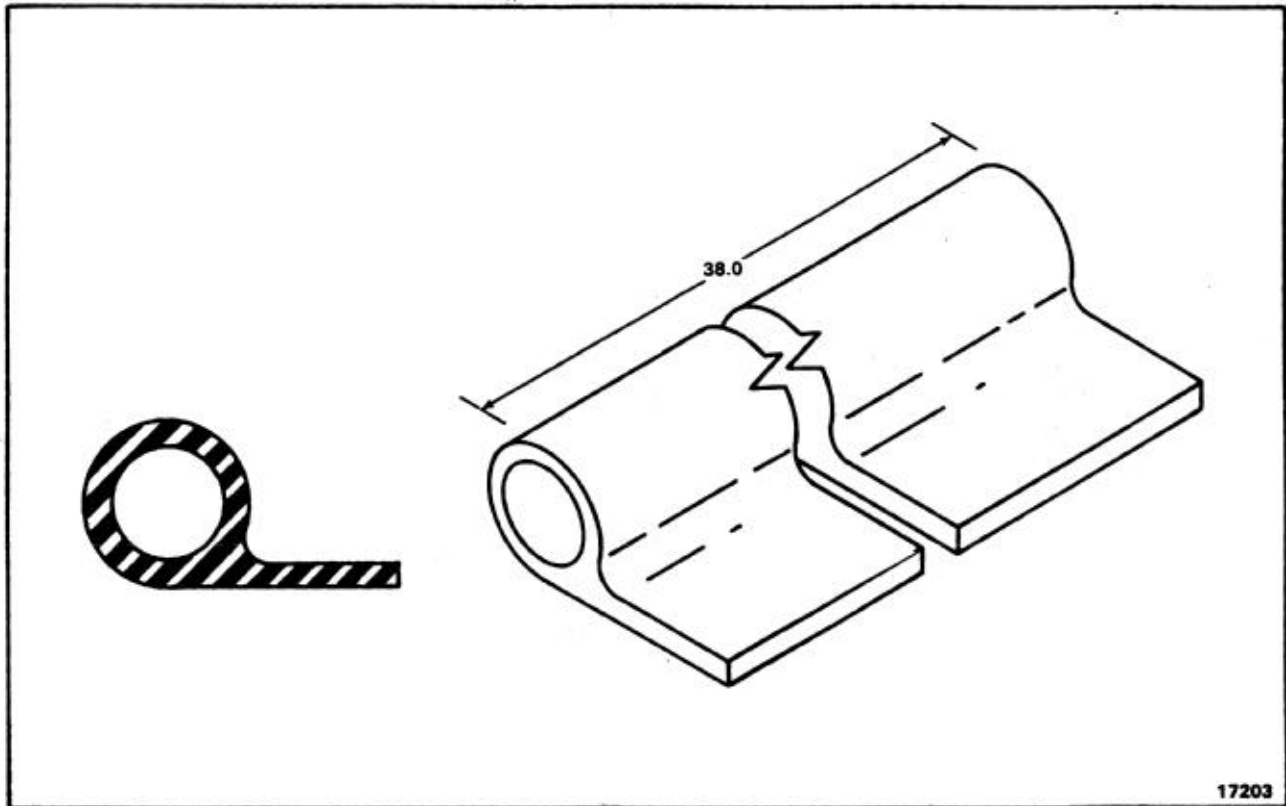

END OF TASK

E-222

NOTES:

1. FABRICATE FROM ALUMINUM ALLOY CLAD SHEET 2024-T3.
2. ALL DIMENSIONS IN INCHES.
3. STOCK SIZE 0.025 X 0.55.
4. 114S3607-198 = 4.0 IN. LG.
114S3607-196 = 58.5 IN. LG.
114S3607-194 = 17.1 IN. LG.
114S3607-193 = 60.5 IN. LG.
114S3607-192 = 12.5 IN. LG.
5. TRIM TO FIT.

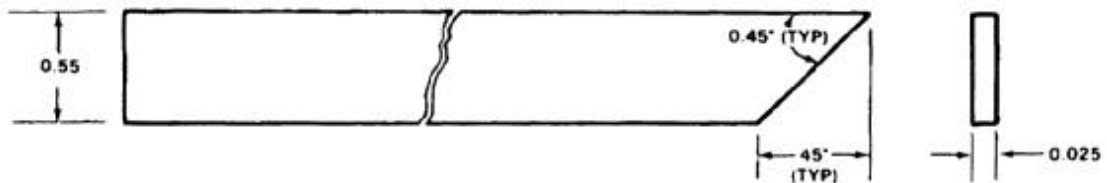

17204

END OF TASK

NOTES:

1. MAKE FROM NONMETALLIC SPECIAL BAC1530-48.
2. ALL DIMENSIONS IN INCHES.
3. 114S3607-182 STOCK SIZE 12.5 LG.
114S3607-183/184 STOCK SIZE 60.5 LG.
114S3607-185/186 STOCK SIZE 17.1 LG.
114S3607-188 STOCK SIZE 58.5 LG.
114S3607-189 STOCK SIZE 4.0 LG.
4. TRIM TO FIT.

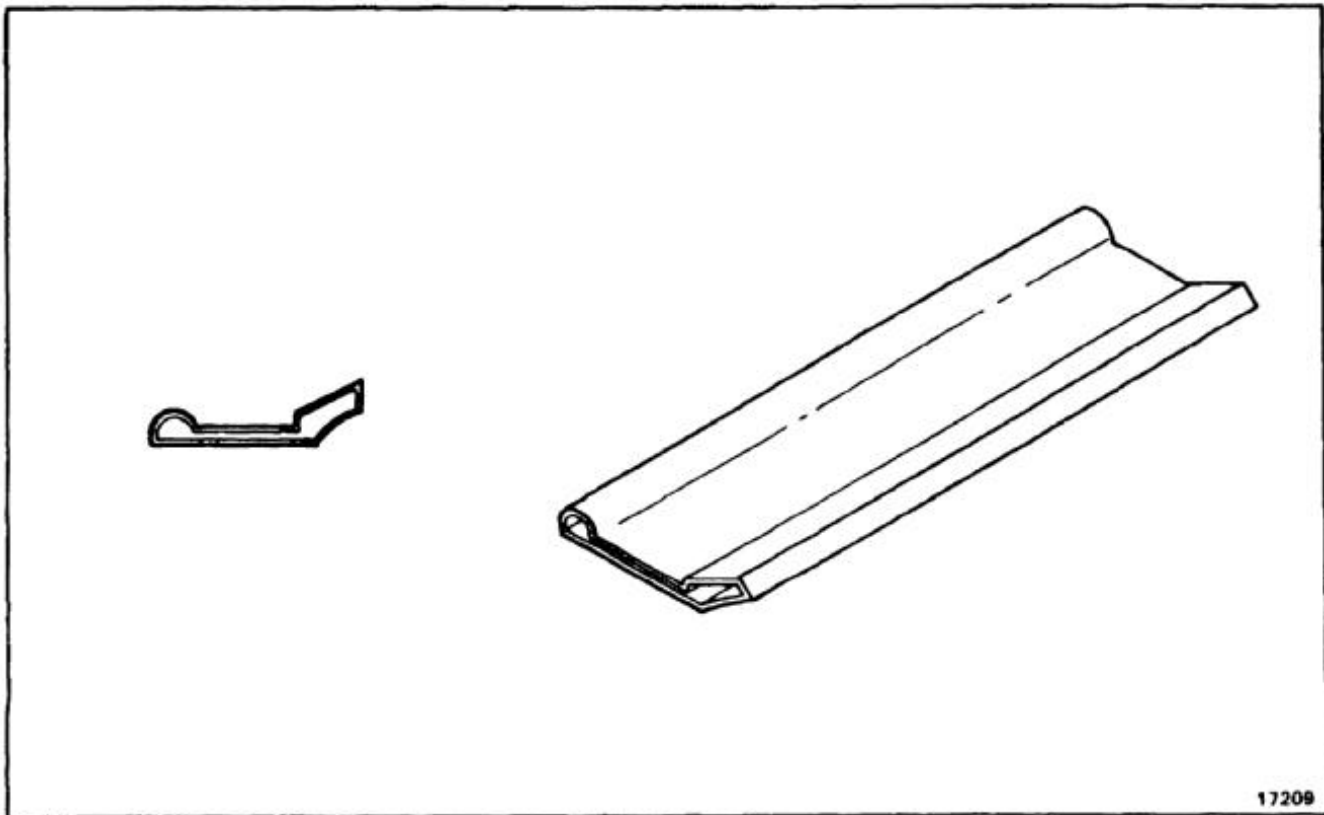

END OF TASK

NOTES:

1. MAKE FROM NONMETALLIC SPECIAL VS80572-3 STRIP.
2. ALL DIMENSIONS IN INCHES.
3. STOCK SIZE 75.0 LG.
4. TRIM TO FIT.
5. -3 PREFERRED, USE -1, -2 TILL DEPLETION.

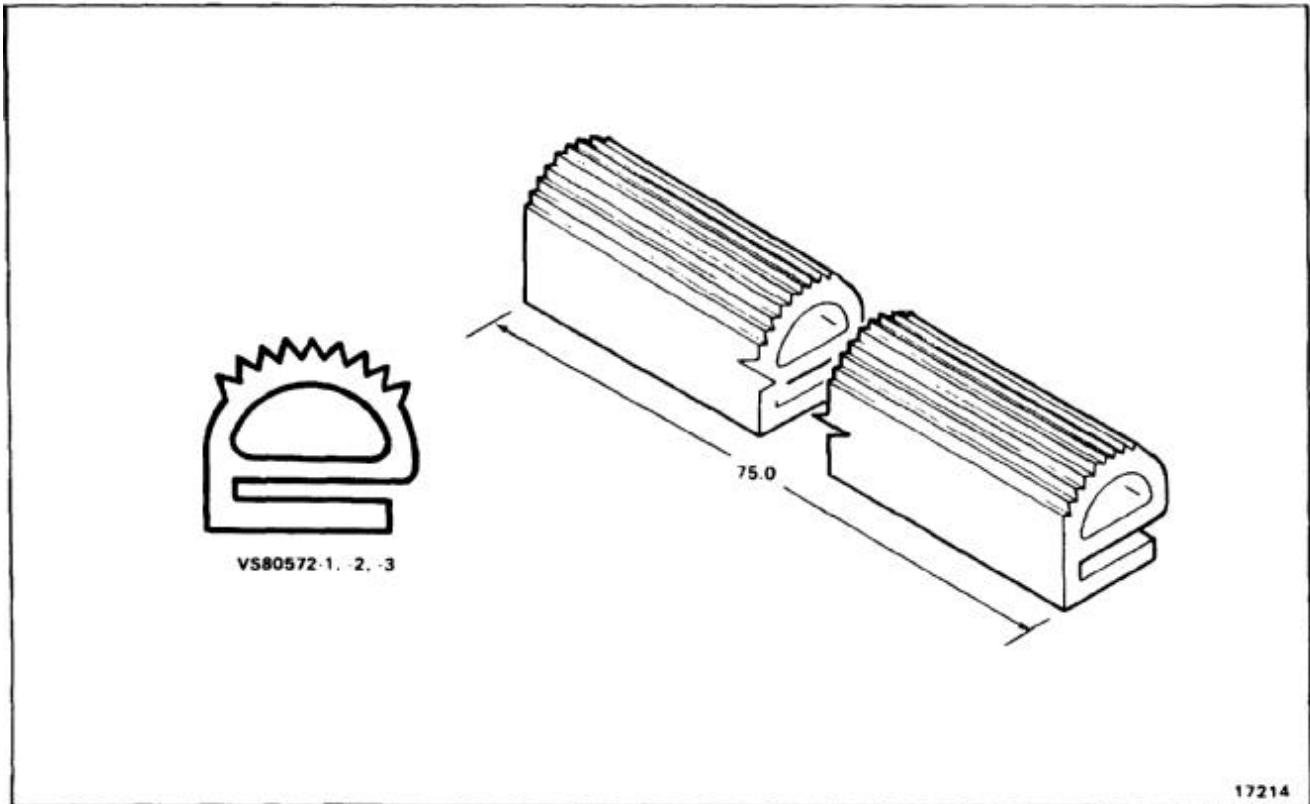

END OF TASK

NOTES:

1. FABRICATE FROM HINGE PN MS2053-2.
2. ALL DIMENSIONS IN INCHES.
3. STOCK SIZE 16.25 INCHES.

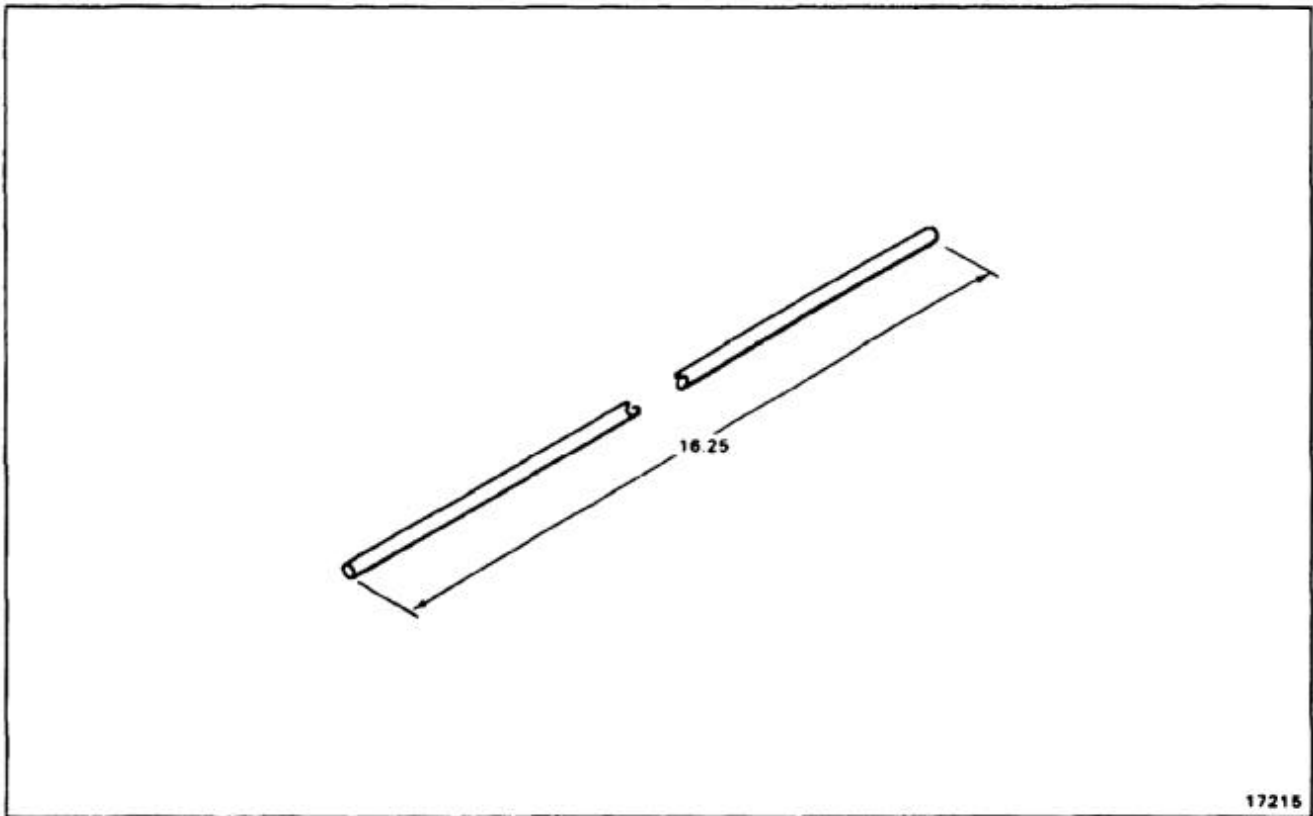

END OF TASK

E-226

NOTES:

1. MAKE FROM SHAPE, NONMETALLIC SILICONE RUBBER CL IB, GR 40, PER ZZ-R-765 VS80572-3.
2. ALL DIMENSIONS IN INCHES.
3. STOCK SIZE 93.0 INCHES LG.

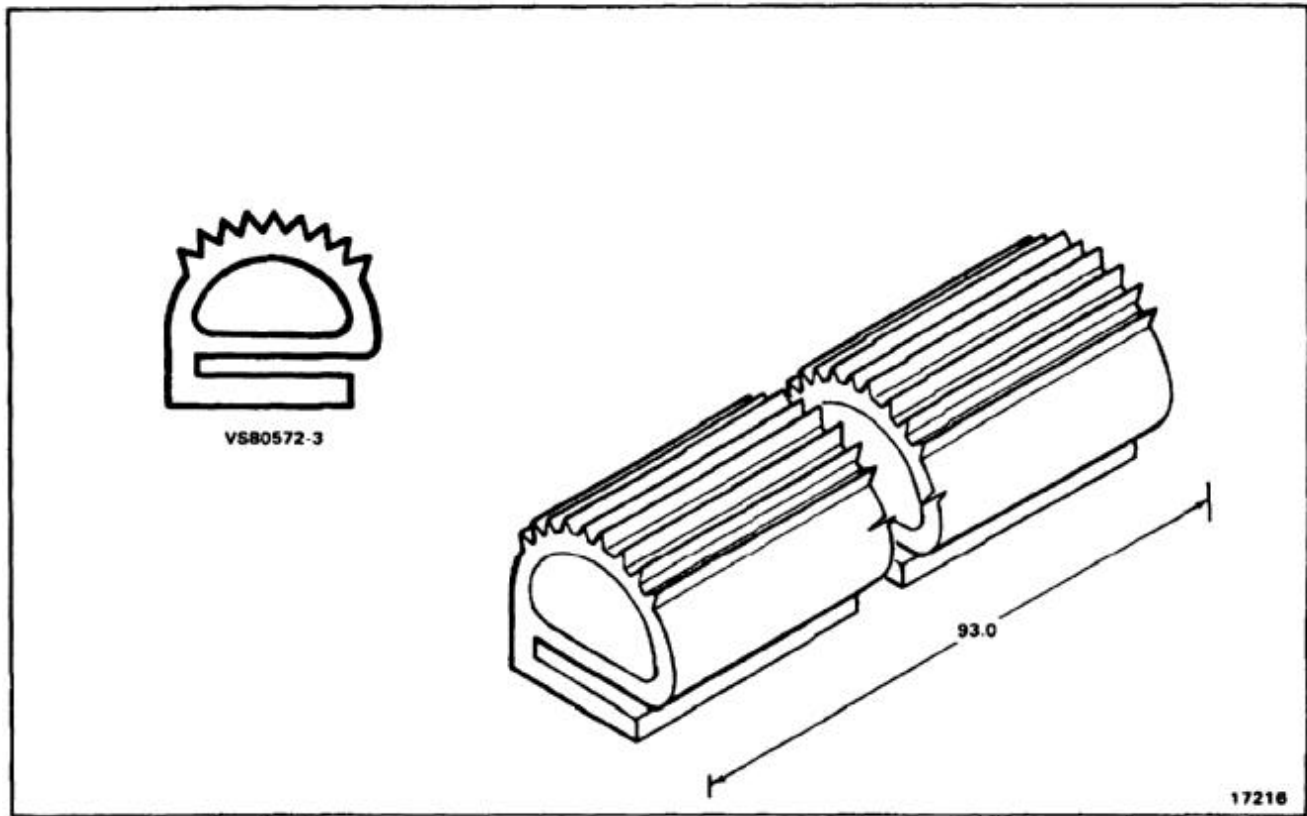

END OF TASK

NOTES:

1. FABRICATE FROM ALUMINUM ALLOY BARE 2024-T3 PER QQ-AZ-250/4.
2. ALL DIMENSIONS IN INCHES.
3. STOCK SIZE 0.040 X 2.4 X 16.85.
4. FINISH AS REQUIRED.

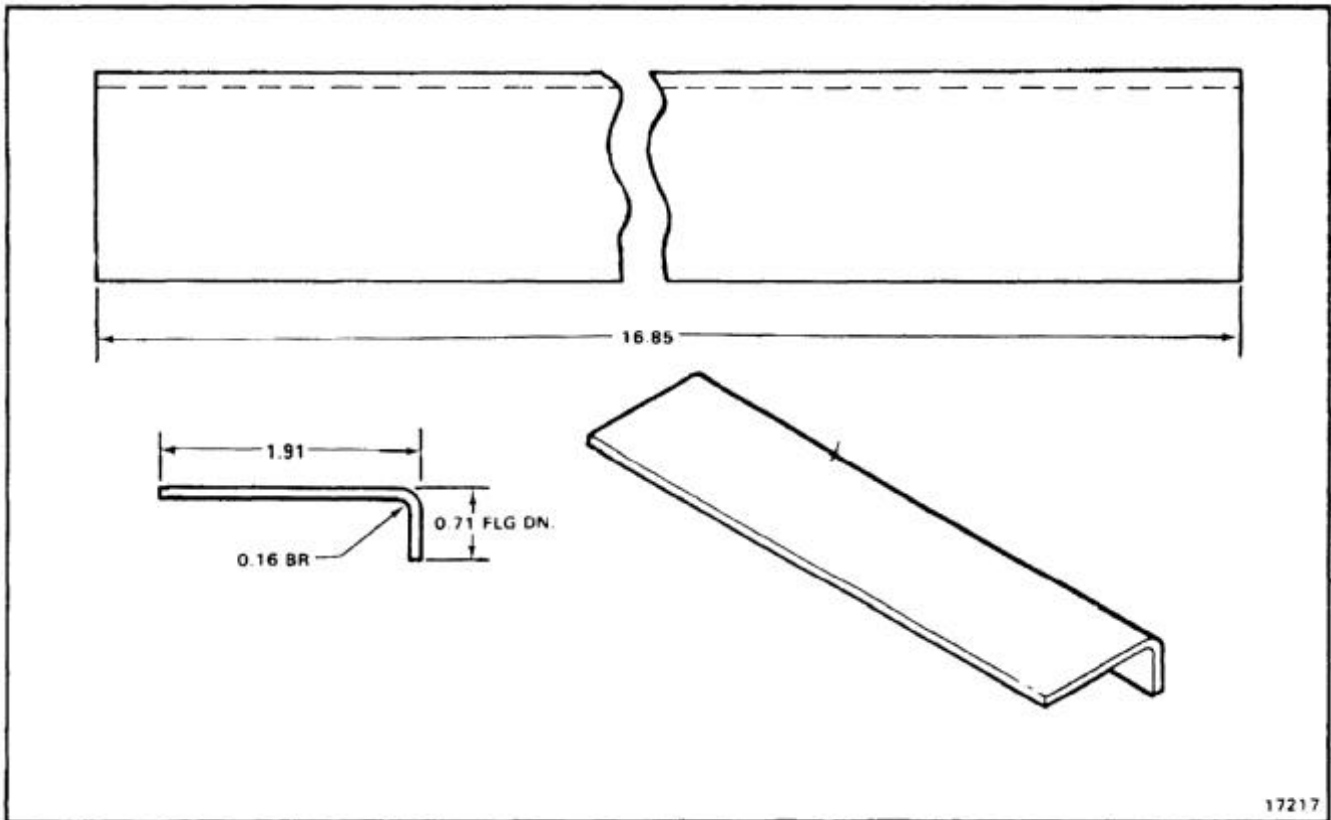

END OF TASK

NOTES:

1. FABRICATE FROM SYNTHETIC RUBBER SHEET MIL-R-6855, CLASS II, GRADE 40.
2. ALL DIMENSIONS IN INCHES.
3. STOCK SIZE 0.063 X 10.0 X 7.7.
4. USE OUTSIDE OF 145S3620-9 COVER AS TEMPLATE TO DETERMINE OUTSIDE: SHAPE 2ND DIMENSIONS AND INSIDE OF 145S3620-10 RETAINER AS TEMPLATE FOR INSIDE CUTOUT.

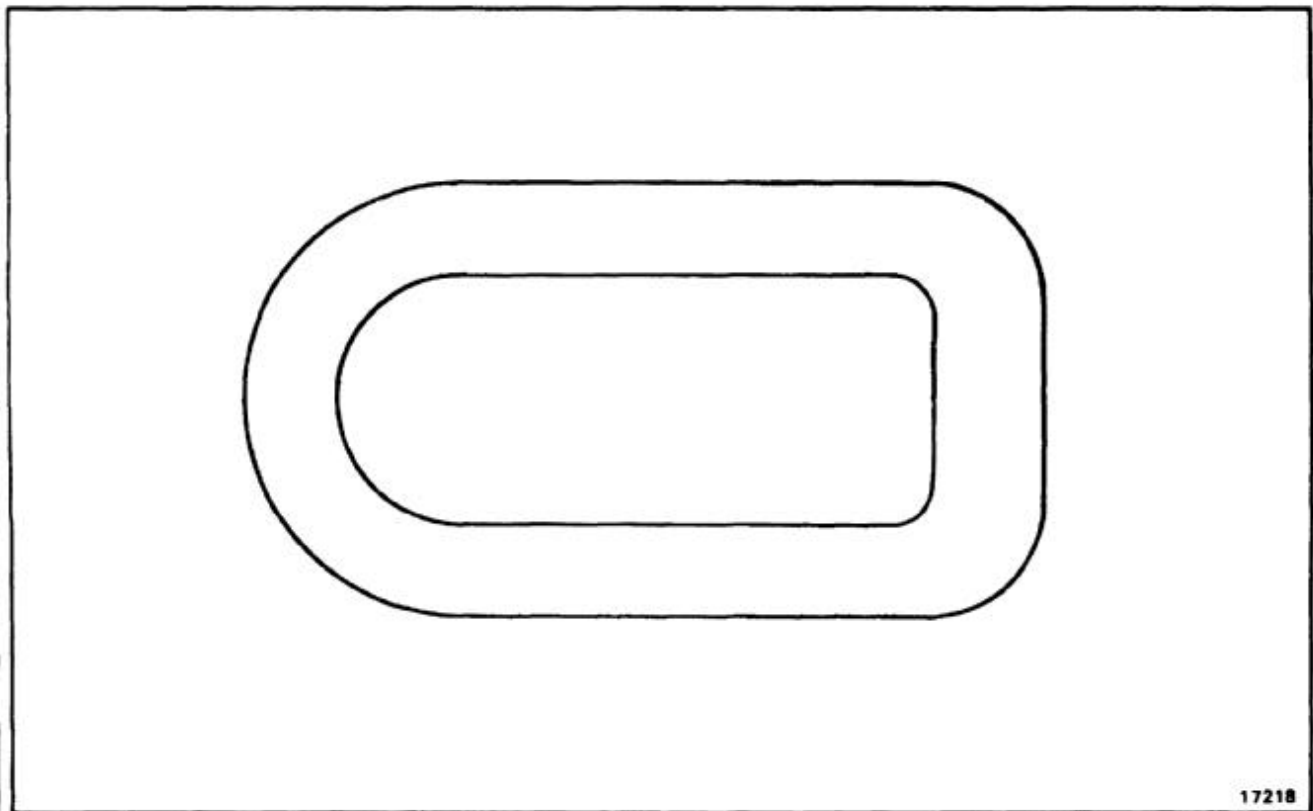

END OF TASK

NOTES:

1. FABRICATE FROM ALUMINUM ALLOY 2024-T4
PER QQ-A-25015.
2. ALL DIMENSIONS IN INCHES.
3. STOCK SIZE 0.040 X 1.0 X 1.0 X 4.0 LG.
4. FINISH AS REQUIRED.

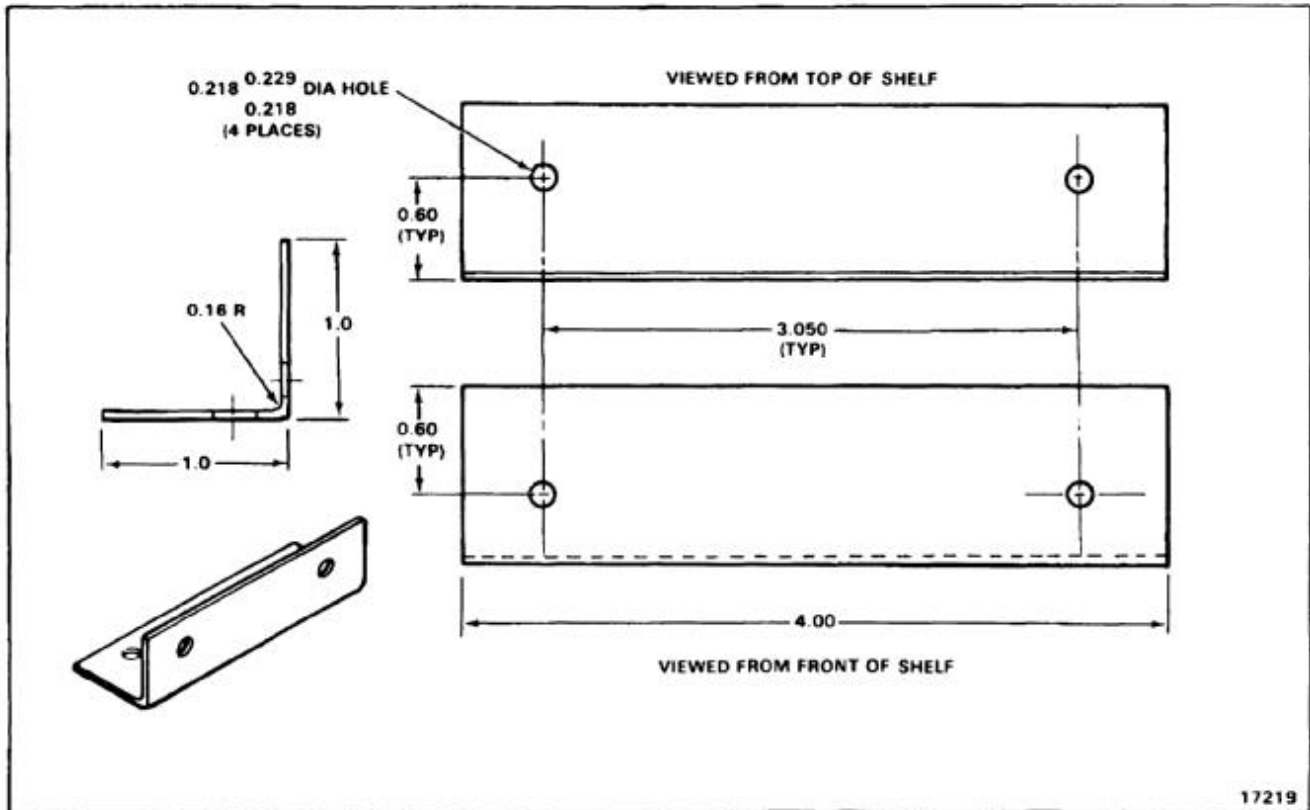

END OF TASK

NOTES:

1. FABRICATE FROM ALUMINUM ALLOY CLAD SHEET 2024-T3 PER QQ-A-250/5.
2. ALL DIMENSIONS IN INCHES.
3. STOCK SIZE 0.040 X 1.0 X 1.0 X 2.0 LG.
4. FINISH AS REQUIRED.

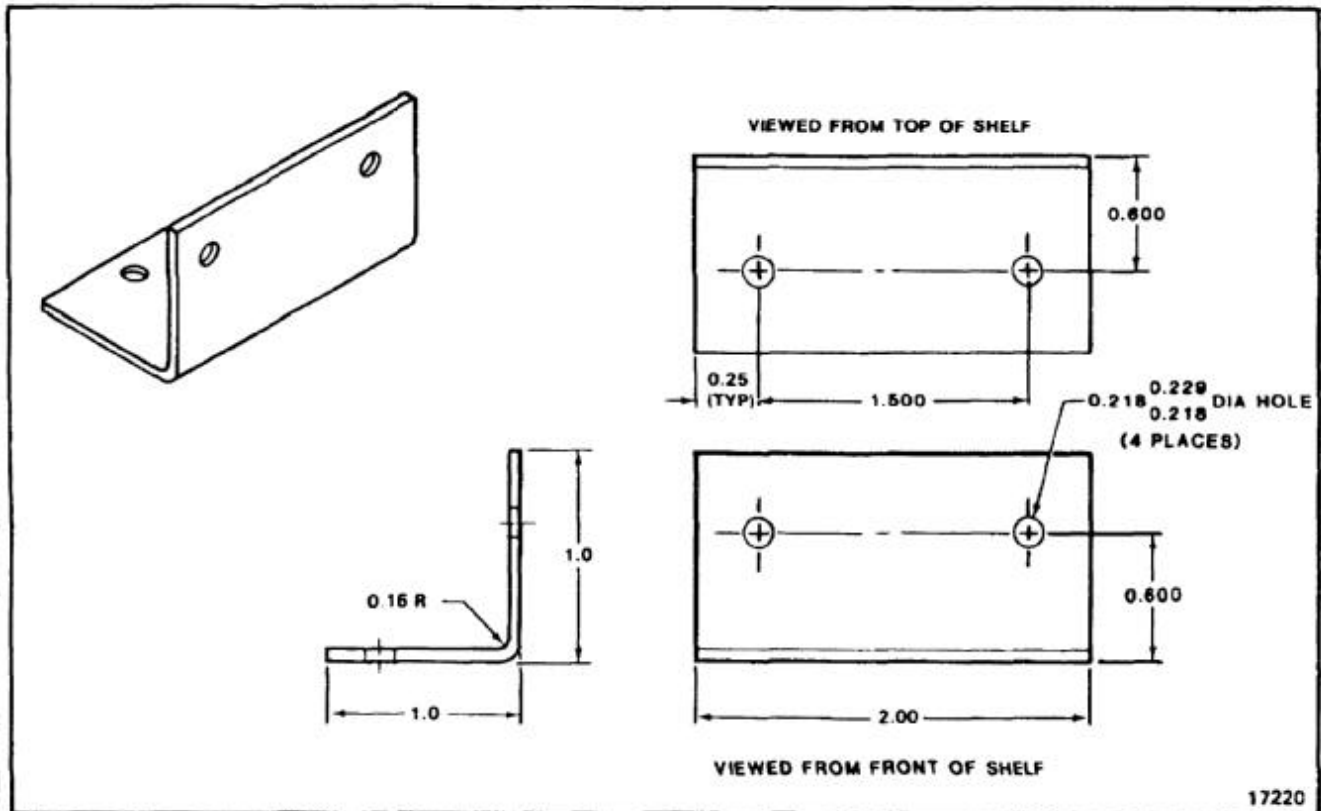

END OF TASK

NOTES:

1. FABRICATE FROM ALUMINUM ALLOY CLAD SHEET 2024-T3 PER QQ-A-250/4.
2. ALL DIMENSIONS IN INCHES.
3. STOCK SIZE 0.040 X 5.5 X 5.1.
4. FINISH WITH ONE COAT OF RED EPOXY PRIMER (E293) MIL-P-52192 (MR) COMPOSITION G, 2 PART SYSTEM APPLIED PER MFR INST. APPLY OVER TWO COATS OF YELLOW PRIMER MIL-P-23377 (E292) APPLIED PER MIL-C-22751.
5. APPLY IDENTIFICATION MARKER TO FACE OF BRACKET.

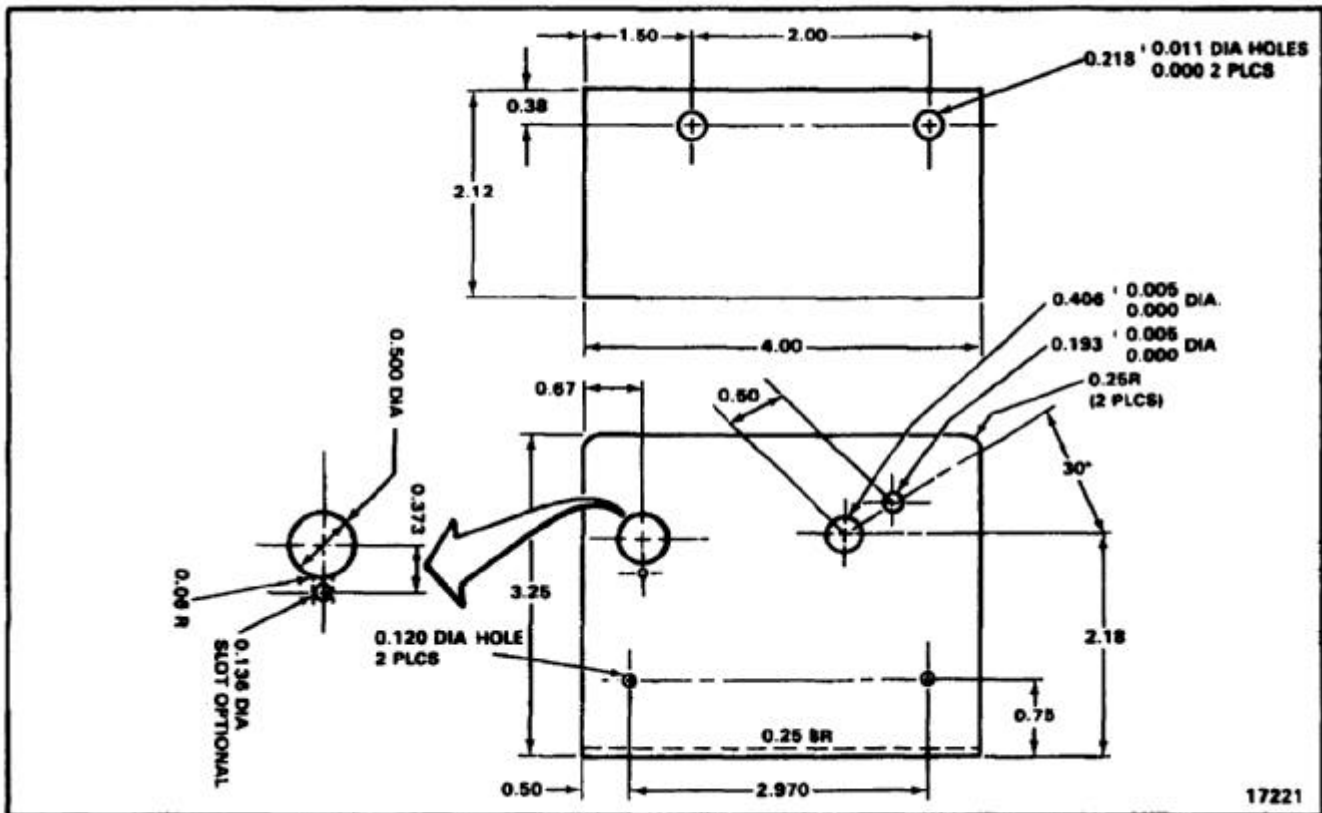

END OF TASK

NOTES:

1. FABRICATE FROM ALUMINUM ALLOY CLAD SHEET 2024-T3 PER QQ-A-250/4.
2. ALL DIMENSIONS IN INCHES.
3. STOCK SIZE 0.063 X 3.0 X 3.8.
4. FINISH WITH ONE COAT OF RED EPOXY PRIMER (E293) MIL-P-52192 (MR) COMPOSITION G, 2 PART SYSTEM APPLIED PER MANUFACTURER'S INSTRUCTIONS ON CONTAINER. APPLY TWO COATS OF YELLOW EPOXY PRIMER MIL-P-23377 (E292) APPLIED PER MIL-C-22751.

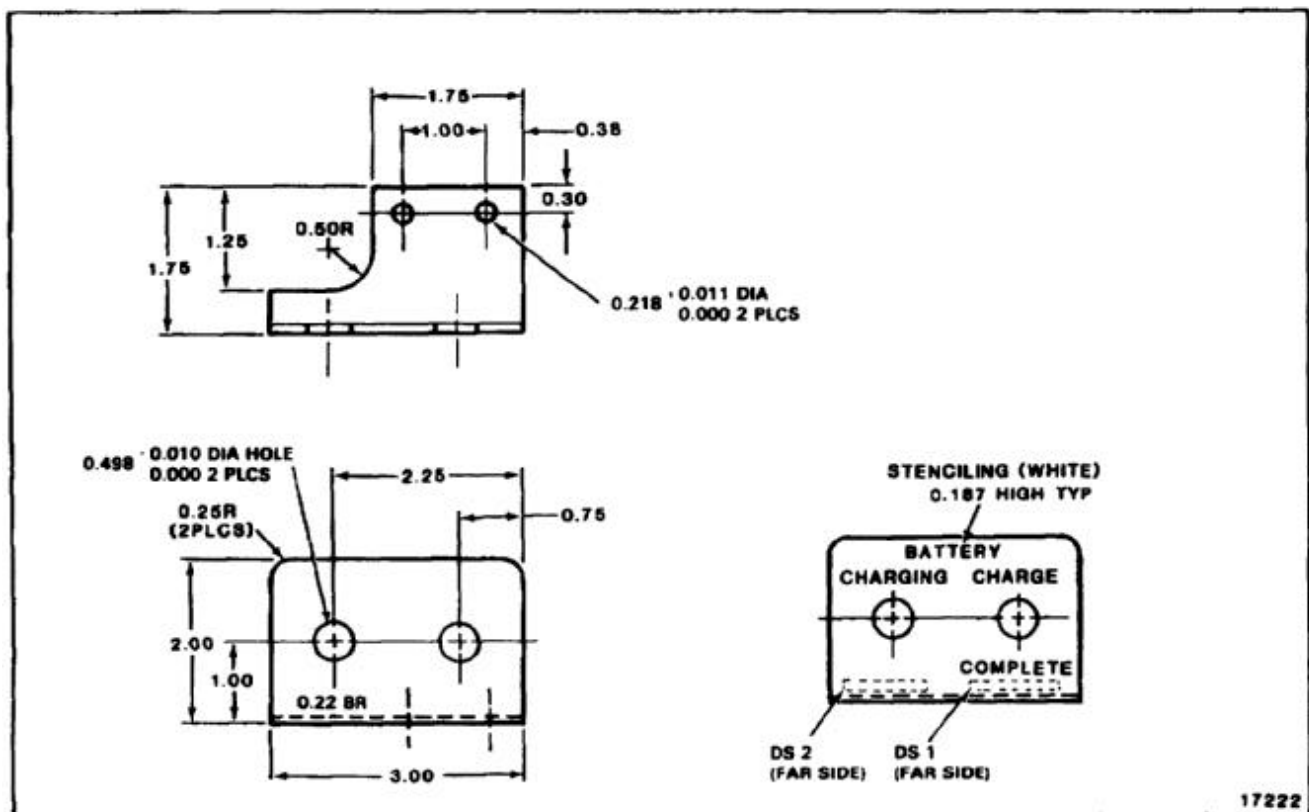

END OF TASK

NOTES:

1. FABRICATE FROM ALUMINUM EXTRUSION
2024-T3511 PER QQ-A-200/3.
2. ALL DIMENSIONS IN INCHES.
3. STOCK AND 10137-1601 X 23.0.
4. USE EXISTING PART AS TEMPLATE.
5. FINISH AS REQUIRED.

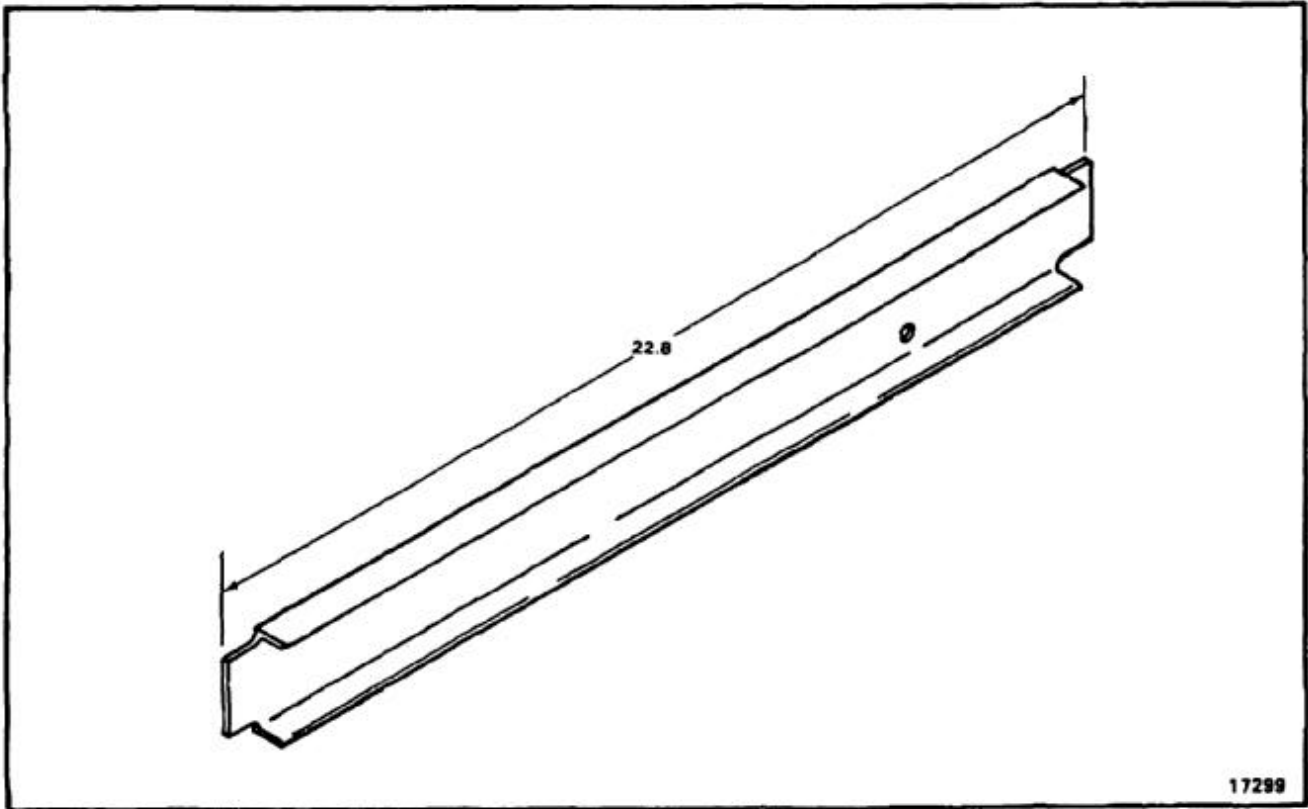

END OF TASK

E-234

NOTES:

1. FABRICATE FROM ALUMINUM EXTRUSION 2024-T3511 PER QQ-A-200/3.
2. ALL DIMENSIONS IN INCHES.
3. STOCK AND 10136-2404 X 1.5.
4. USE EXISTING PART AS TEMPLATE.
5. FINISH AS REQUIRED.

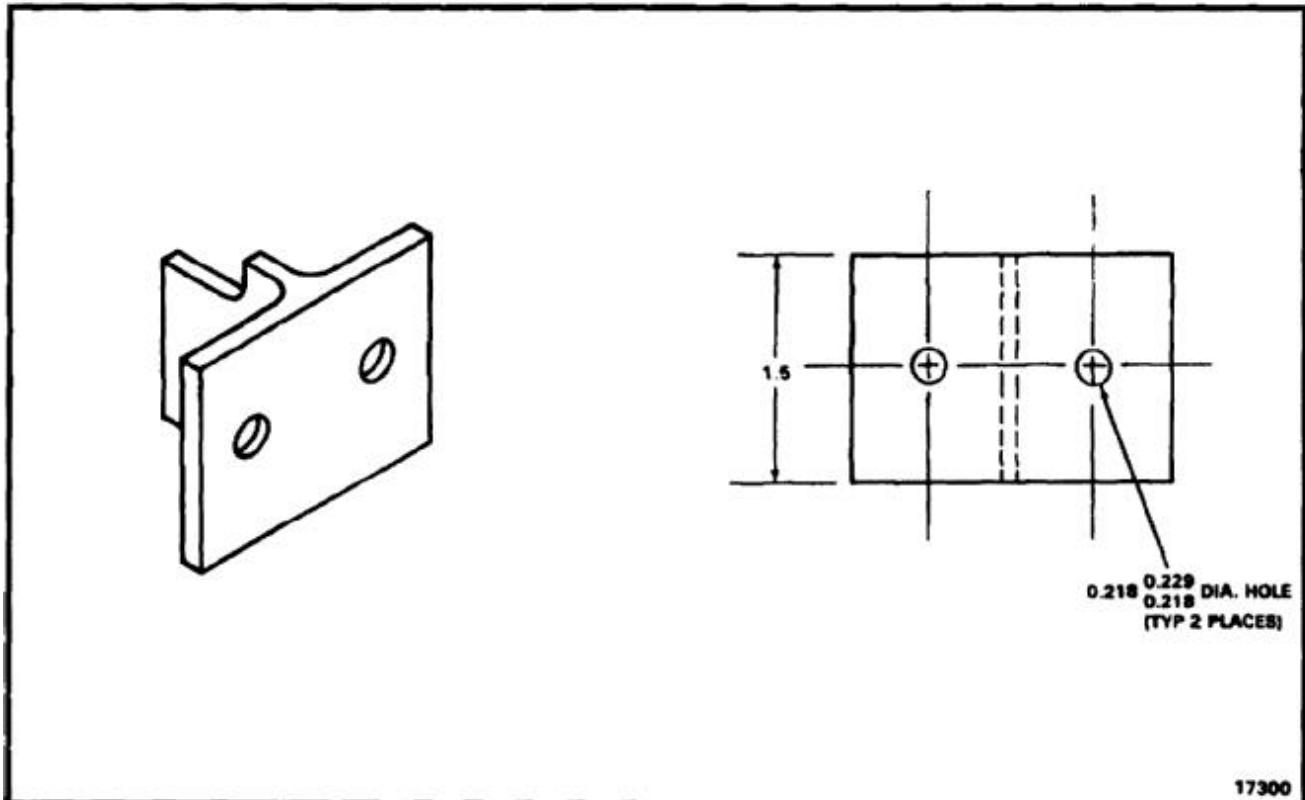

END OF TASK

NOTES:

1. FABRICATE FROM ALUMINUM EXTRUSION 2024-T3511 PER QQ-A-200/3.
2. ALL DIMENSIONS IN INCHES.
3. STOCK AND 10137-1601 X 23.0.
4. USE EXISTING PART AS TEMPLATE.
5. FINISH AS REQUIRED.

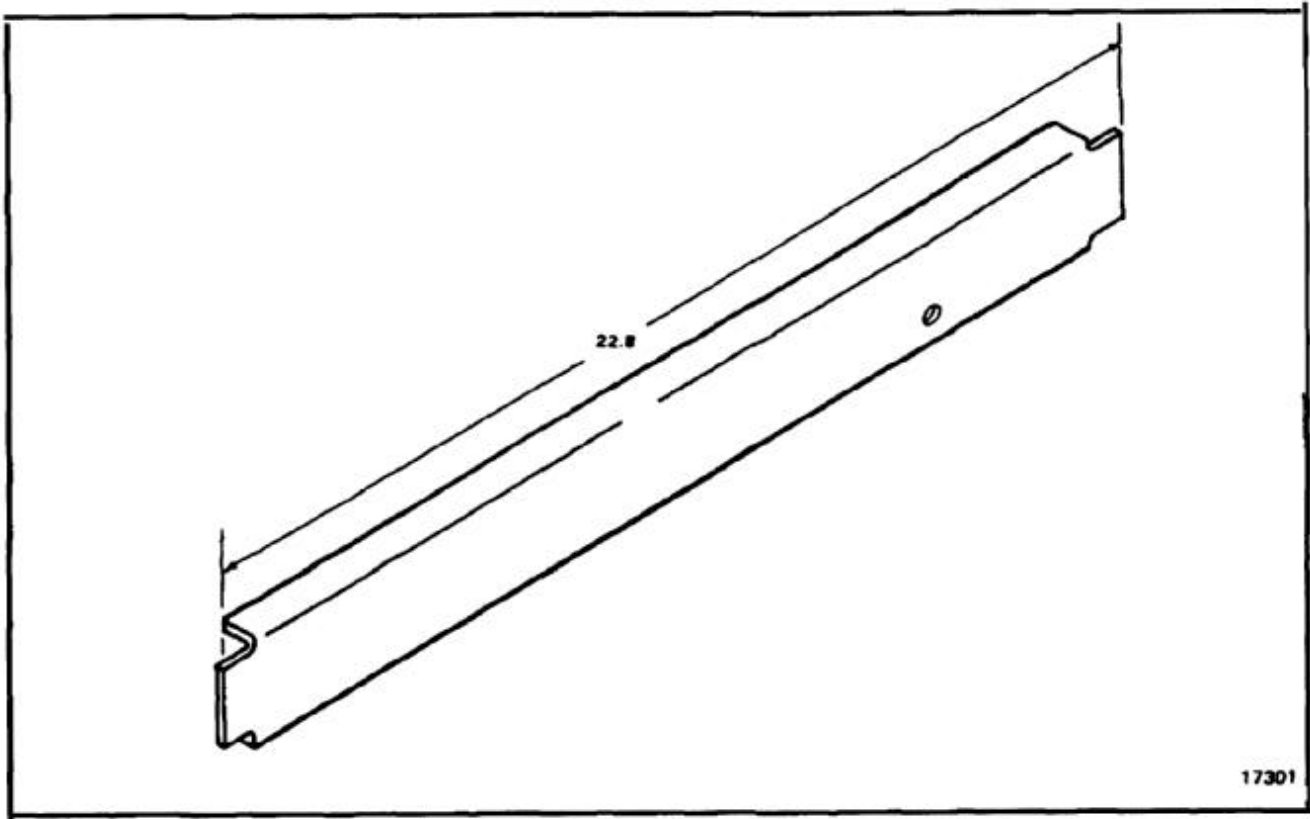

END OF TASK

NOTES:

1. FABRICATE FROM ALUMINUM EXTRUSION 2024-T3511 PER QQ-A-200/3.
2. ALL DIMENSIONS IN INCHES.
3. STOCK AND 10137-1601 X 19.0.
4. USE EXISTING PART AS TEMPLATE.
5. FINISH AS REQUIRED.

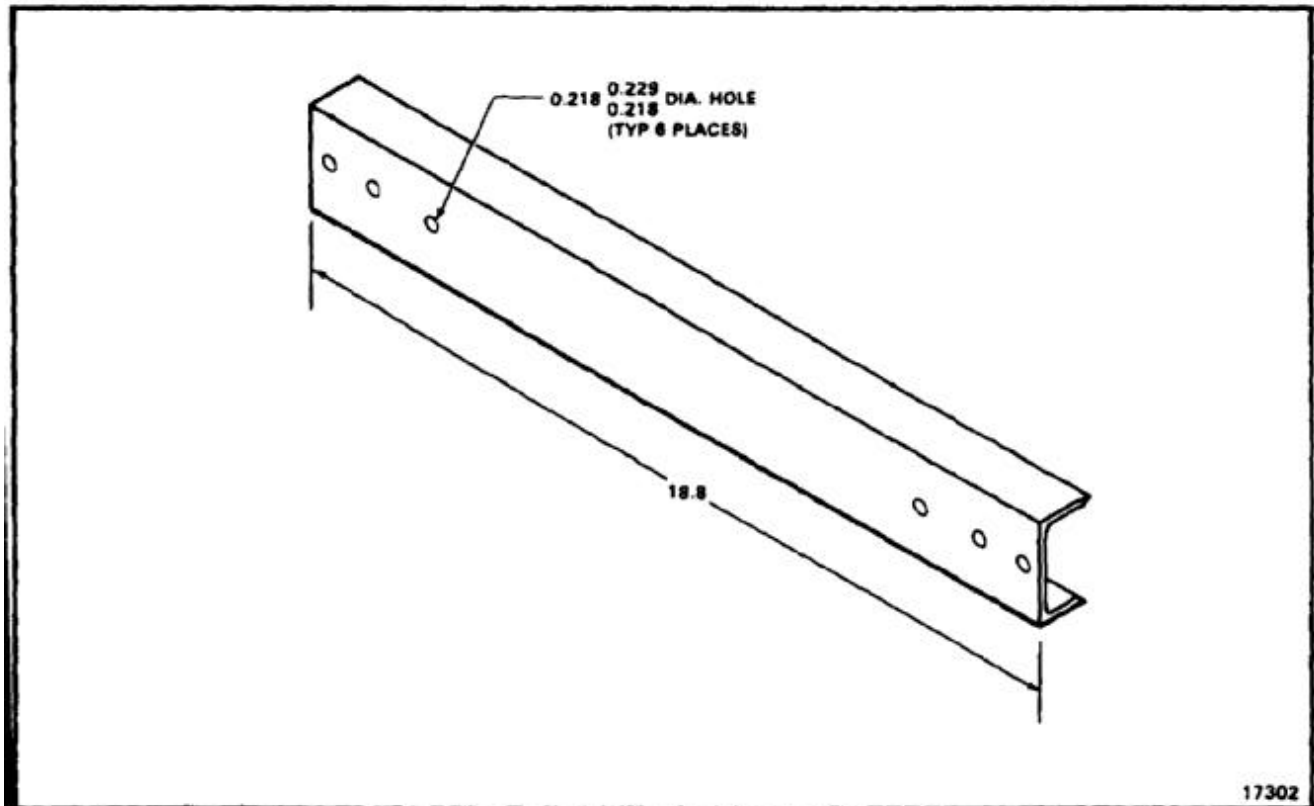

END OF TASK

NOTES:

1. MAKE FROM ALUMINUM ALLOY 2024-T3 CLAD SHEET PER QQ-A-250/5.
2. ALL DIMENSIONS IN INCHES.
3. STOCK SIZE 0.040 X 2.25 X 2.38.
4. USE OLD BRACKET FOR TEMPLATE TO MATCH RELAY AND MOUNT HOLES.
5. PAINT WITH WHITE CLYPTOL 1201 (E164) AS REQUIRED.

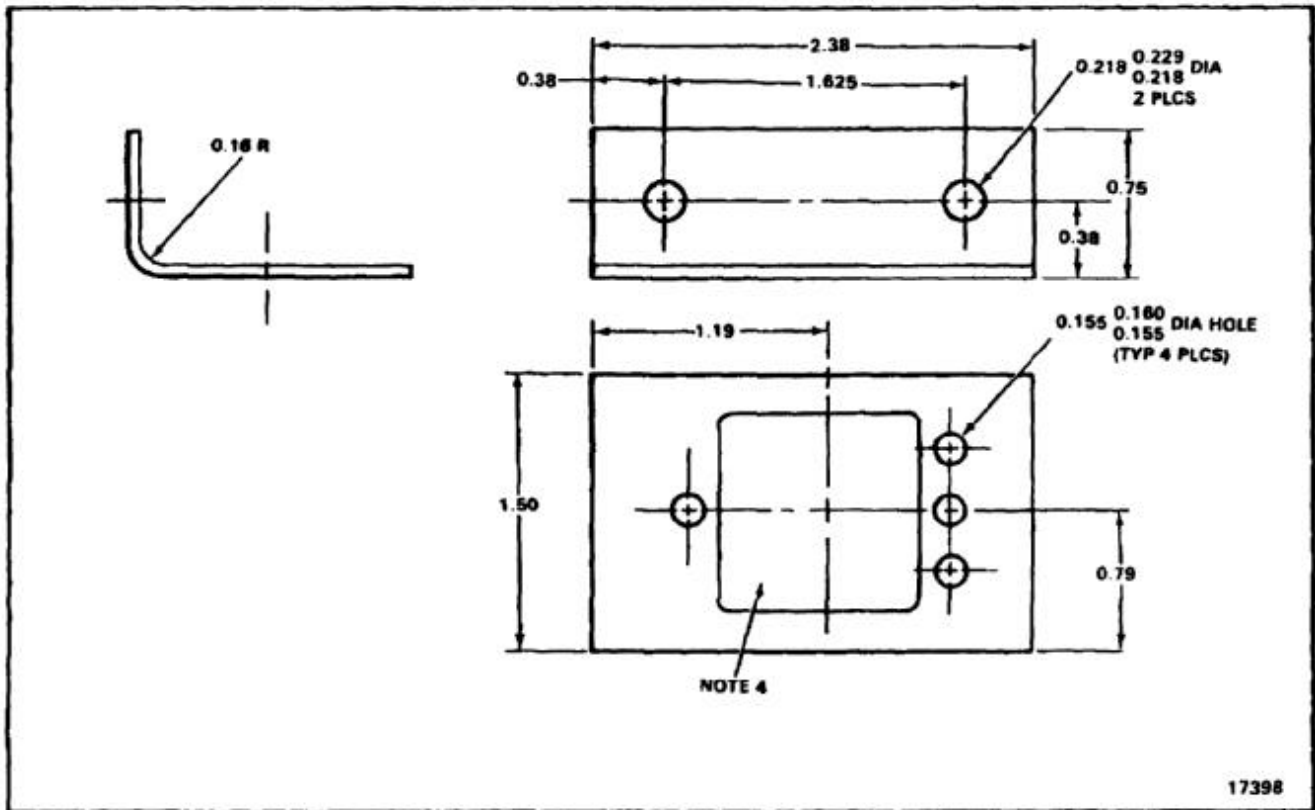

END OF TASK

NOTES:

1. FABRICATE FROM ALUMINUM ALLOY SHEET CLAD 2024-T3.
2. ALL DIMENSIONS IN INCHES.
3. STOCK SIZE 0.050 X 1.7 X 7.9.
4. USE OLD PLATE FOR TEMPLATE TO LOCATE RIVET HOLES AND CENTER HOLE IN REPLACEMENT.
5. LENGTH OF REPLACEMENT IS SAME AS ORIGINAL.
6. FINISH AS REQUIRED.

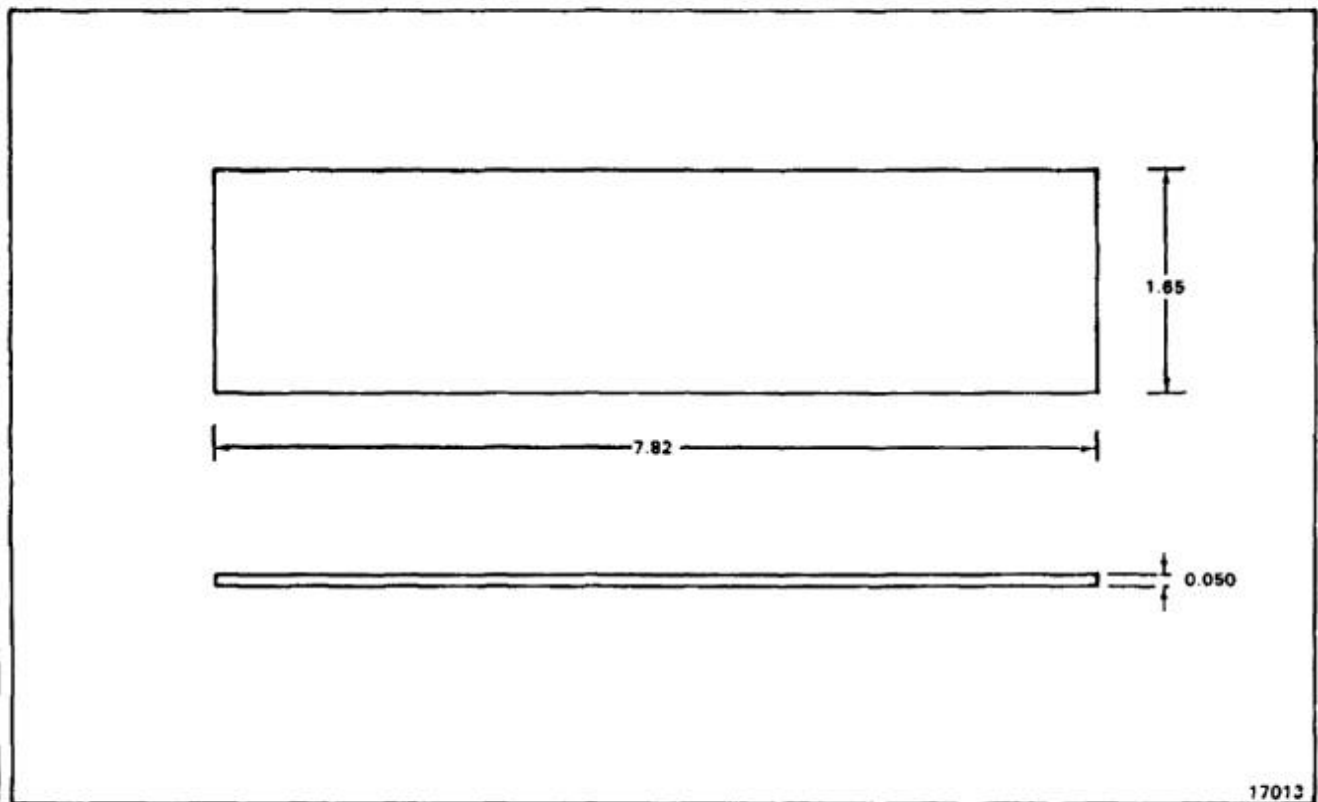

END OF TASK

NOTES:

1. MAKE FROM NONMETALLIC SPECIAL RUBBER SEAL VS80526, NSN 9390-00-289-8702.
2. ALL DIMENSIONS IN INCHES.
3. STOCK SIZE 64.4 LG.
4. TRIM TO FIT.

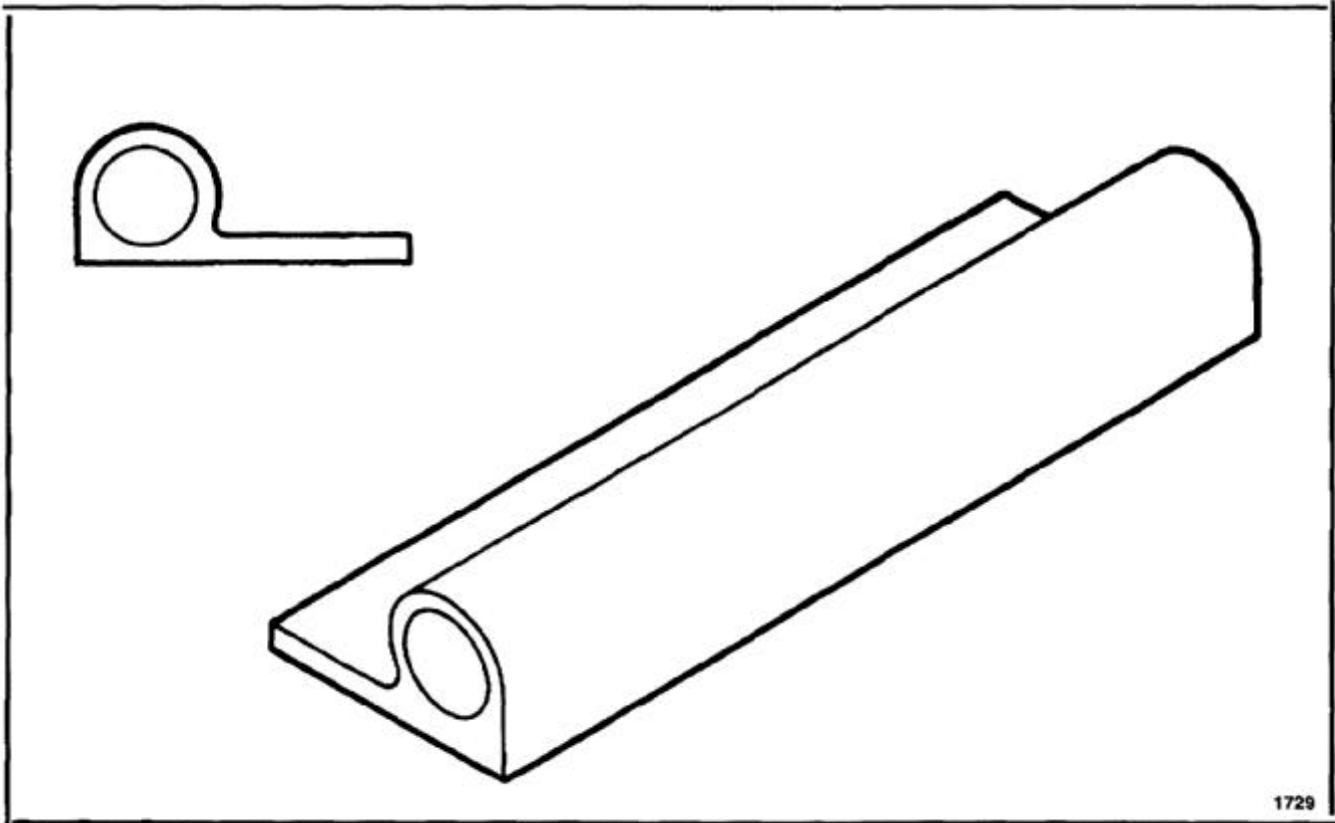

END OF TASK

E-240

NOTES:

1. MAKE FROM RUBBER SPECIAL NONMETALLIC VS80572-1, -2, OR -3.
2. ALL DIMENSIONS IN INCHES.
3. STOCK SIZE 20.0 LG.
4. TRIM TO FIT.
5. USE -1 AND -2 TILL DEPLETION.

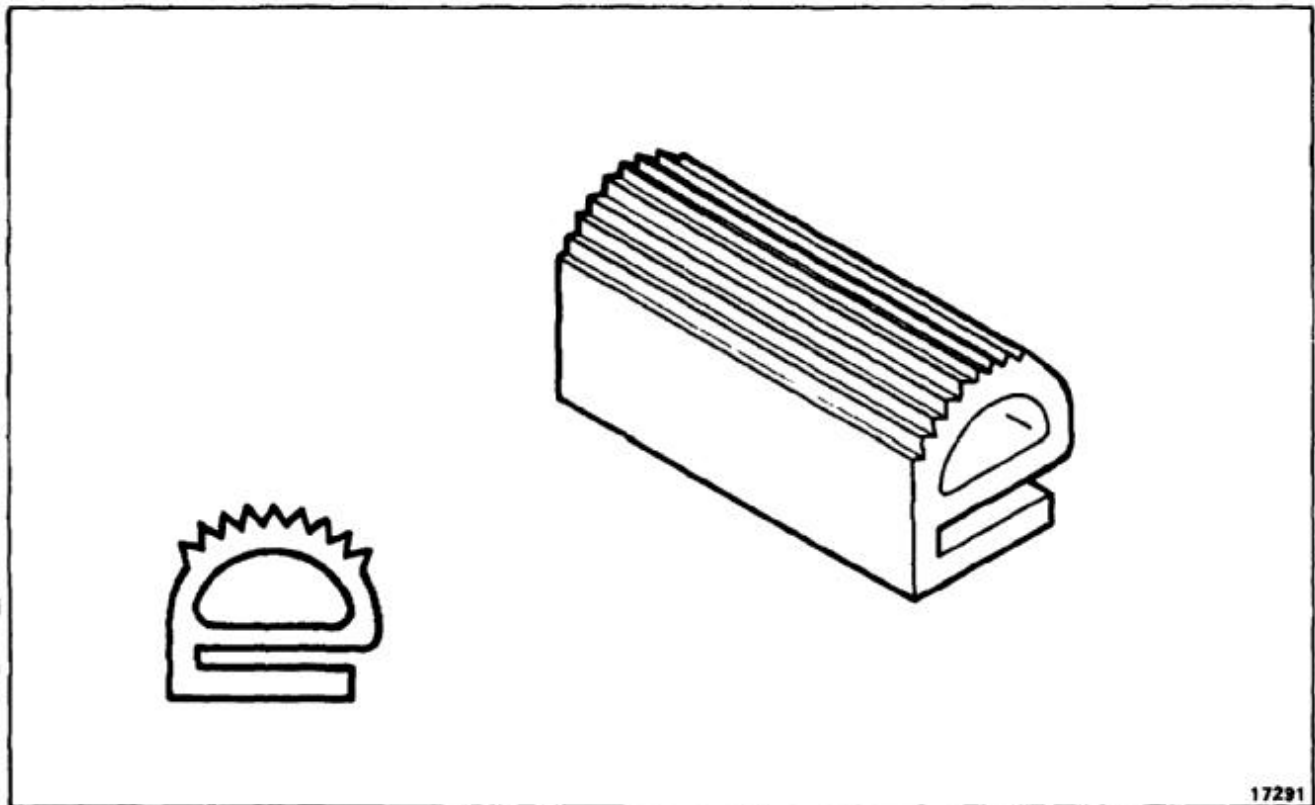

END OF TASK

NOTES:

1. MAKE FROM RUBBER SHAPE NONMETALLIC VS80536-1.
2. ALL DIMENSIONS IN INCHES.
3. STOCK SIZE 32.0 LG.
4. TRIM TO FIT.

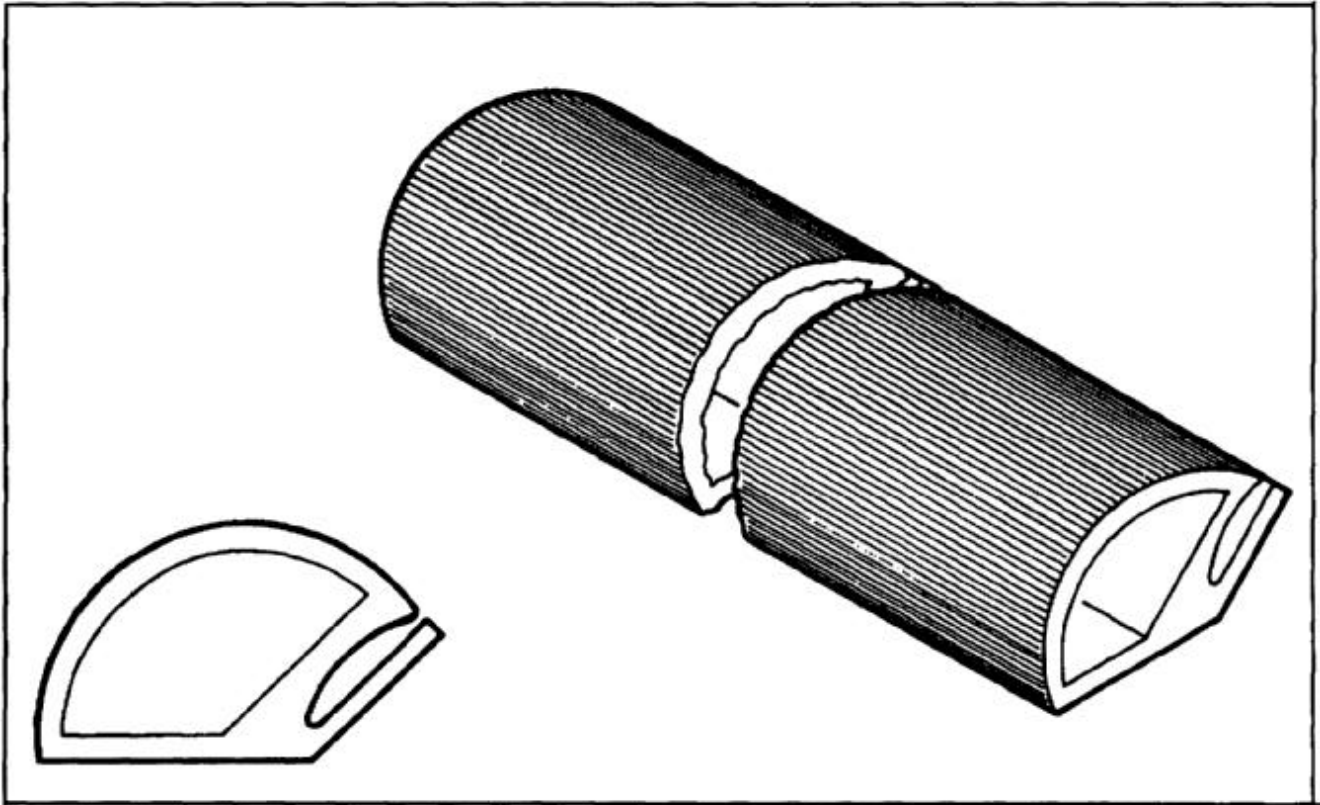

END OF TASK

E-242

NOTES:

1. FABRICATE FROM ALUMINUM LAMINATED SHIM PER MIL-S-22499 COMPOSITION I, TYPE I.
2. ALL DIMENSIONS IN INCHES.
3. STOCK SIZE 0.032 X 3.6 X 4.7.
4. REFER TO -33 FOR SHIM DIMENSIONS.
5. FINISH AS REQUIRED.

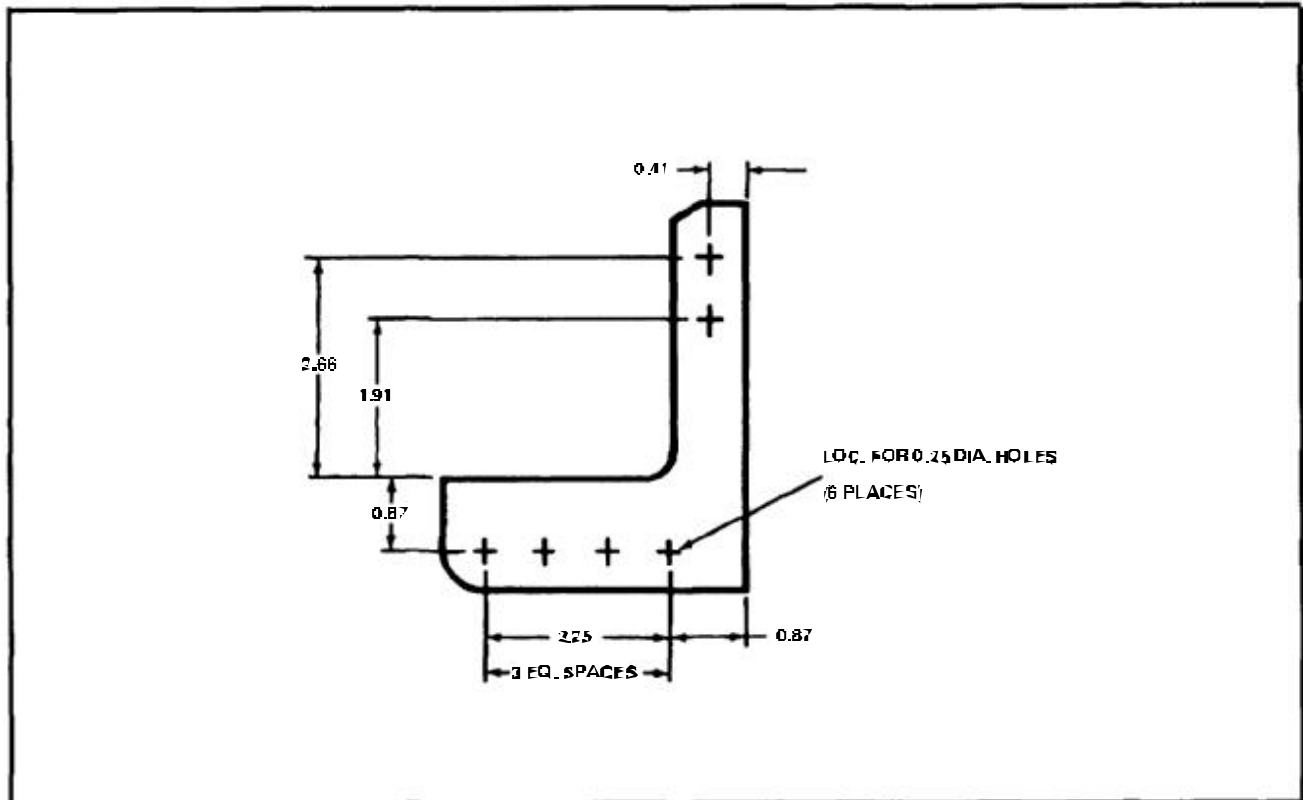

END OF TASK

NOTES:

1. FABRICATE FROM ALUMINUM LAMINATED SHIM PER MIL-S-22499 COMPOSITION I, TYPE I.
2. ALL DIMENSIONS IN INCHES.
3. STOCK SIZE 0.032 X 3.6 X 4.7.
4. FINISH AS REQUIRED.

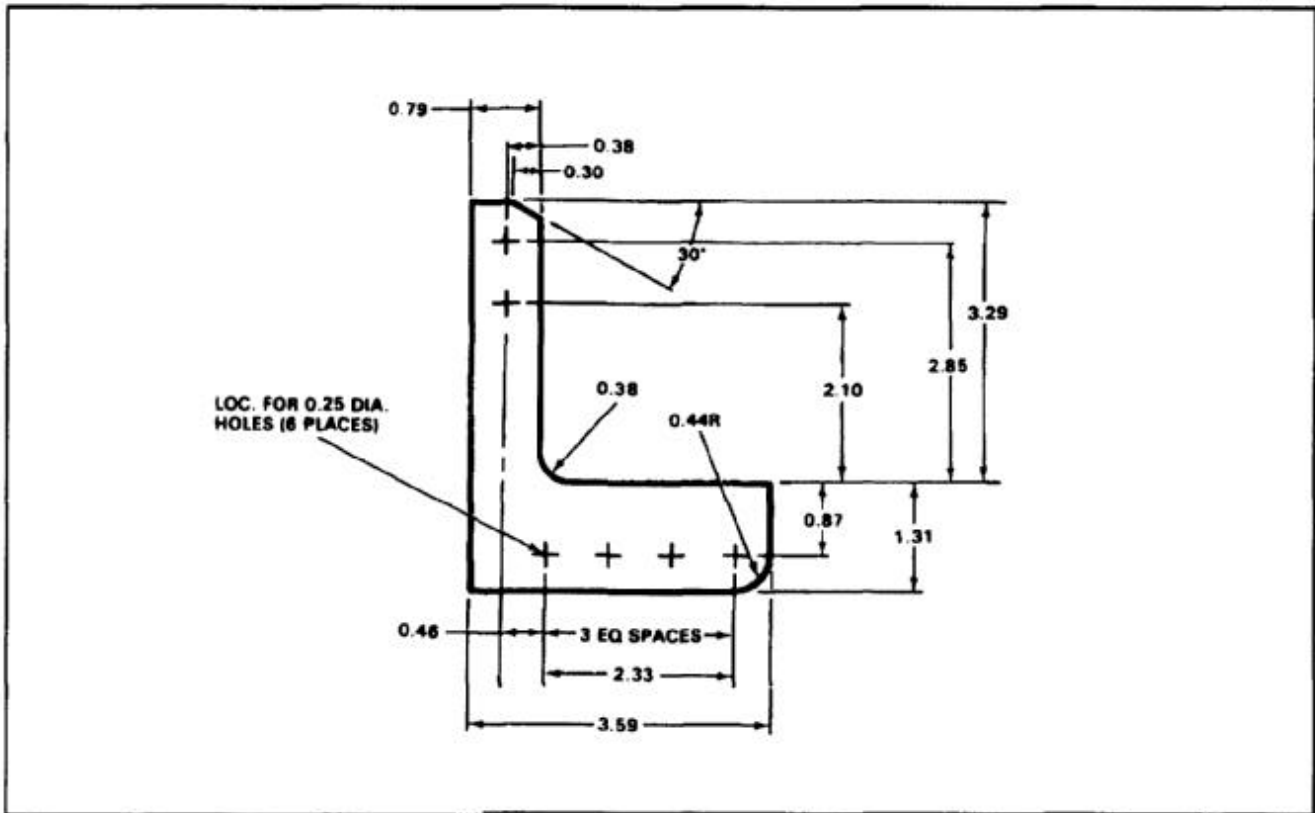

END OF TASK

NOTES:

1. FABRICATE FROM ALUMINUM LAMINATED SHIM PER MIL-S-22499 COMPOSITION I, TYPE I.
2. ALL DIMENSIONS IN INCHES.
3. STOCK SIZE 0.032 X 2.2 X 3.7.
4. FINISH AS REQUIRED.

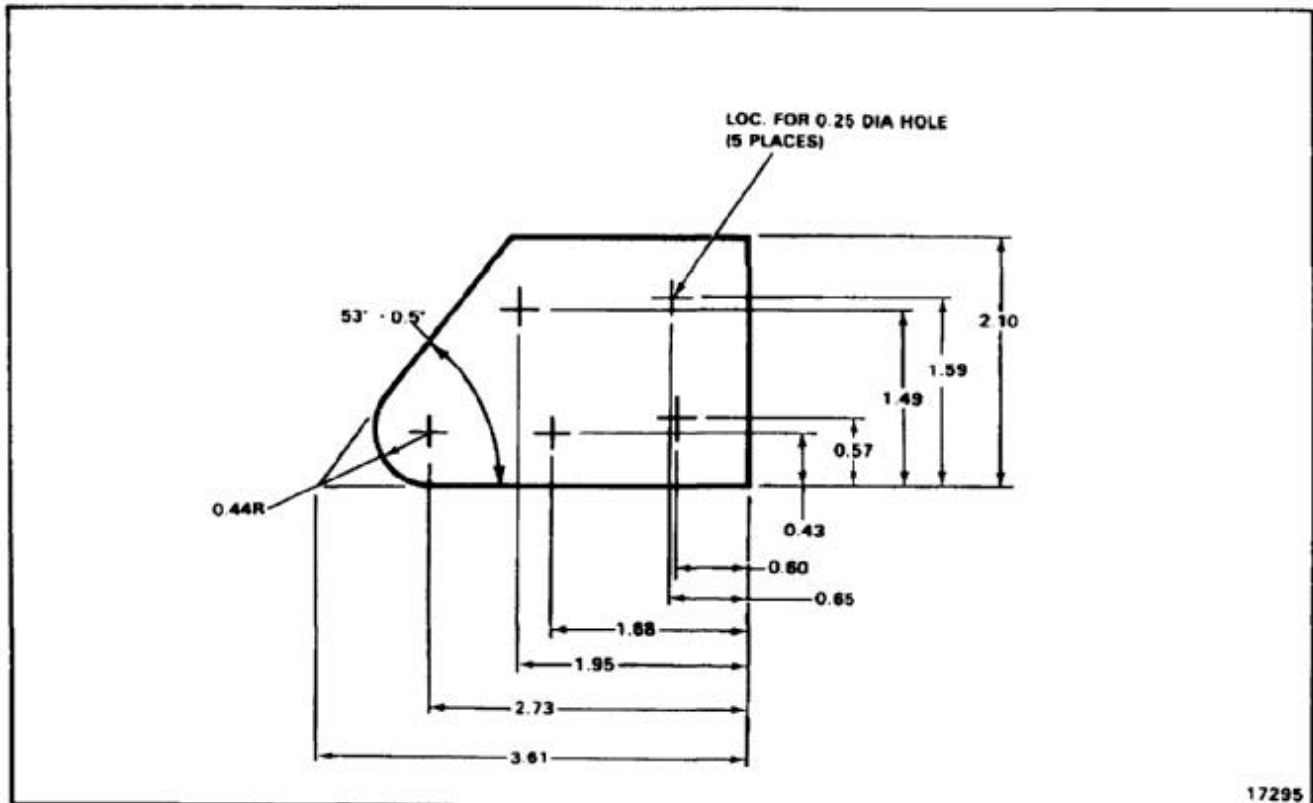

END OF TASK

NOTES:

1. FABRICATE FROM ALUMINUM LAMINATED SHIM PER MIL-S-22499 COMPOSITION I, TYPE I.
2. ALL DIMENSIONS IN INCHES.
3. STOCK SIZE 0.032 X 2.5 X 3.5.
4. FINISH AS REQUIRED.

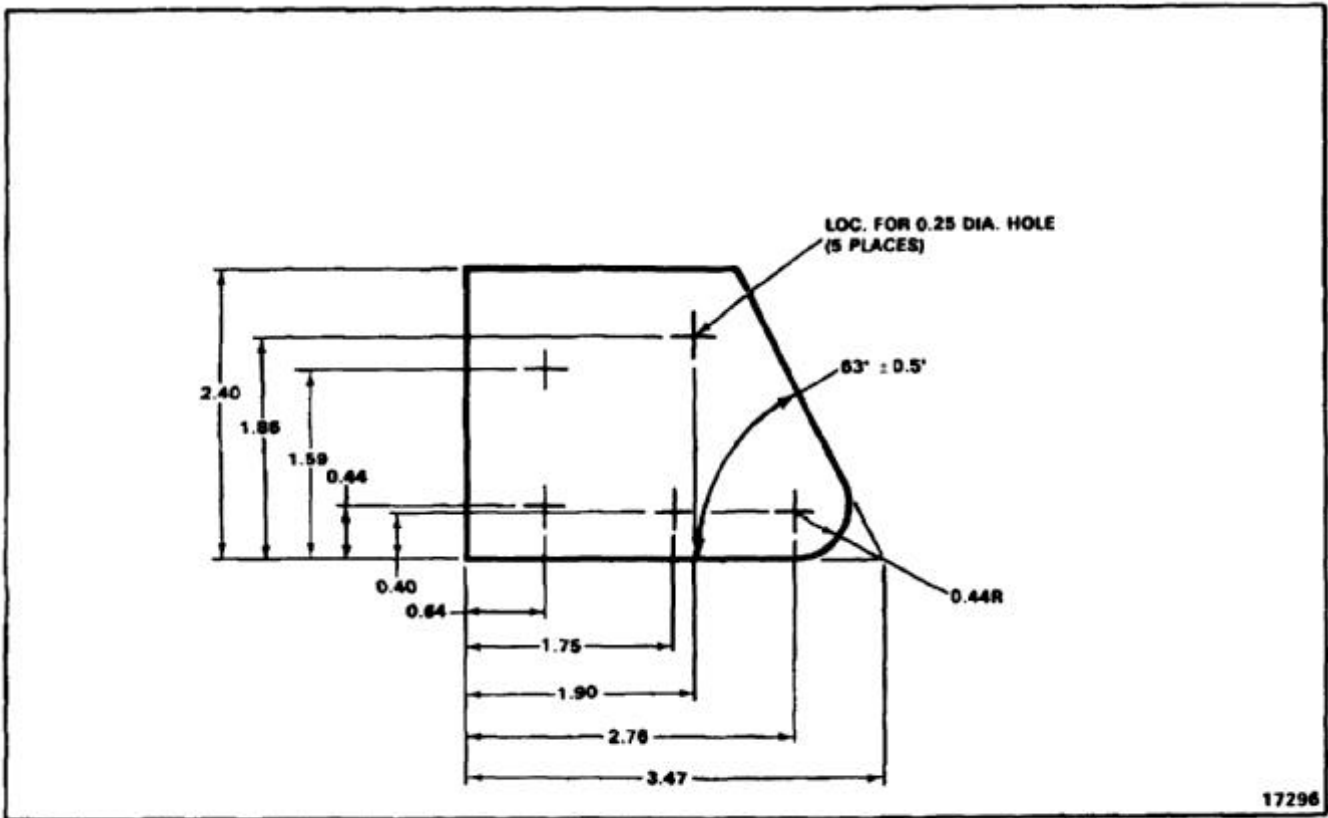

END OF TASK

NOTES:

1. FABRICATE FROM ALUMINUM ALLOY 2024-T3 CLAD SHEET PER QQ-A-200/5.
2. ALL DIMENSIONS IN INCHES.
3. STOCK SIZE 0.032 X 1.2 X 2.8.
4. FINISH WITH ONE COAT OF RED EPOXY PRIMER (E293) MIL-P-52192 (MR) COMPOSITIONING, 2 PART SYSTEM APPLIED PER MANUFACTURER'S INSTRUCTIONS ON CONTAINER. APPLY OVER TWO COATS OF YELLOW EPOXY PRIMER (E292) MIL-P-23377 APPLIED PER MIL-C-22751.

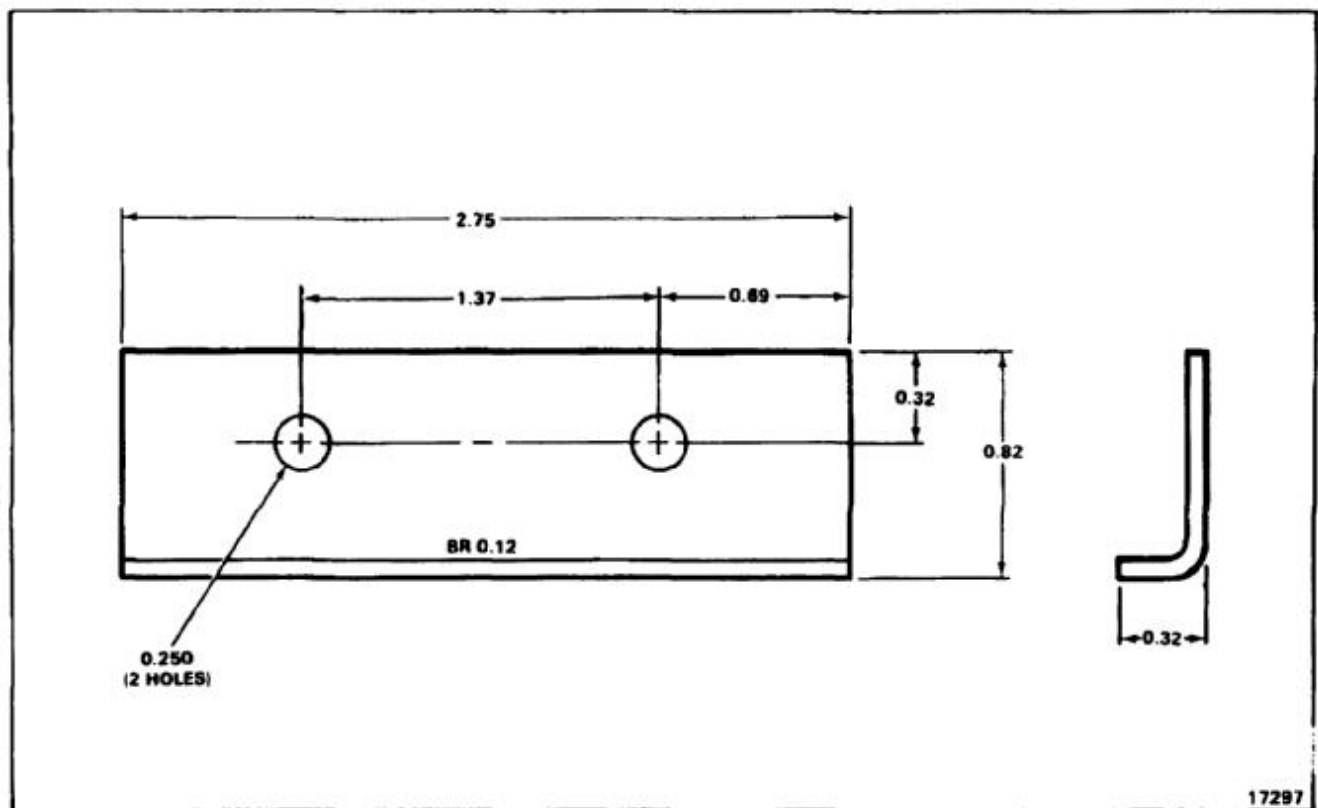

END OF TASK

NOTES:

1. FABRICATE FROM ALUMINUM ALLOY 2024-T3 CLAD SHEET PER QQ-A-200/5.
2. ALL DIMENSIONS IN INCHES.
3. STOCK SIZE 0.032 X 1.2 X 5.7.
4. FINISH WITH ONE COAT OF RED EPOXY PRIMER (E293) MIL-P-52192 (MR) COMPOSITIONING, 2 PART SYSTEM APPLIED PER MANUFACTURER'S INSTRUCTIONS ON CONTAINER. APPLY OVER TWO COATS OF YELLOW EPOXY PRIMER (E292) MIL-P-23377 APPLIED PER MIL-C-22751.

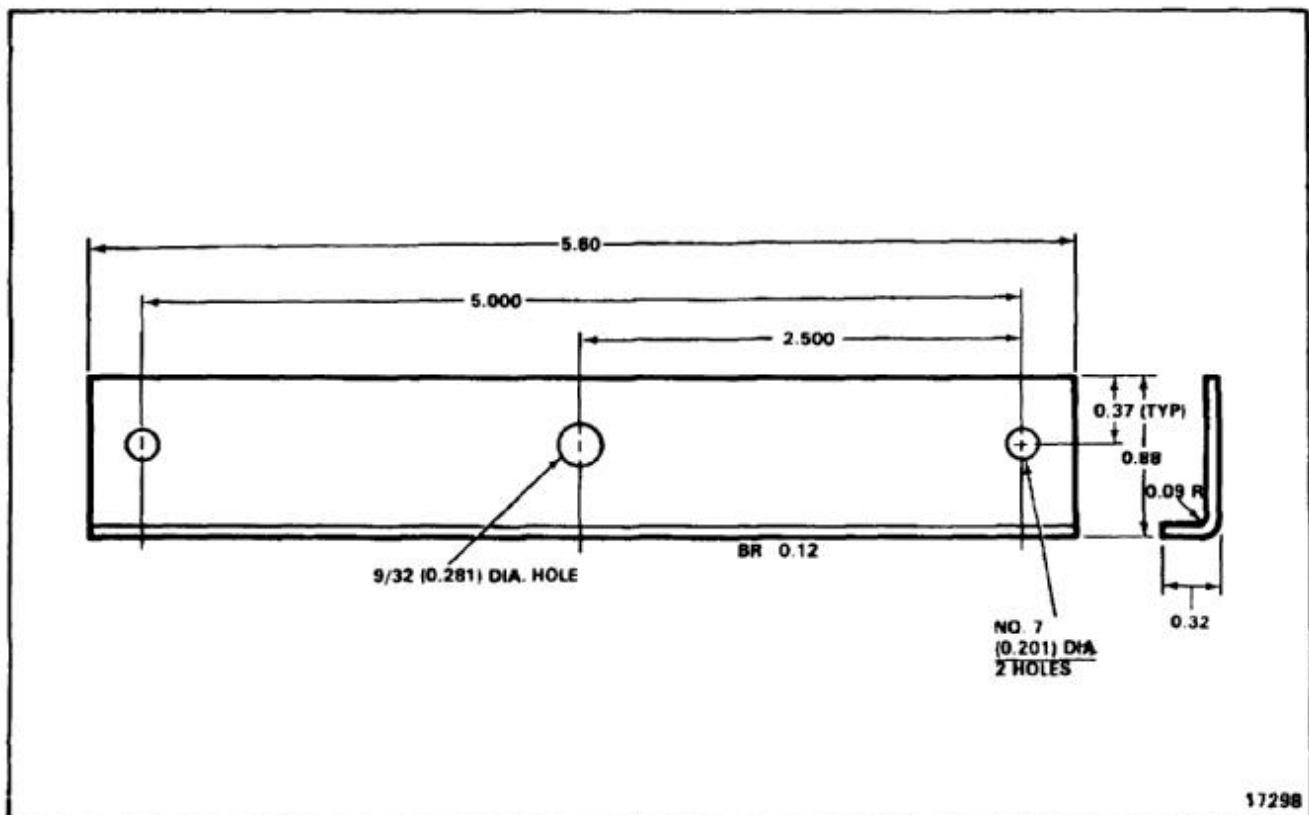

END OF TASK

NOTES:

1. MAKE FROM VS8055-1 SILICONE RUBBER.
2. ALL DIMENSIONS IN INCHES.
3. STOCK LENGTH FOR -31 IS 39.20.
4. STOCK LENGTH FOR -33 IS 34.90.
5. TRIM TO FIT.

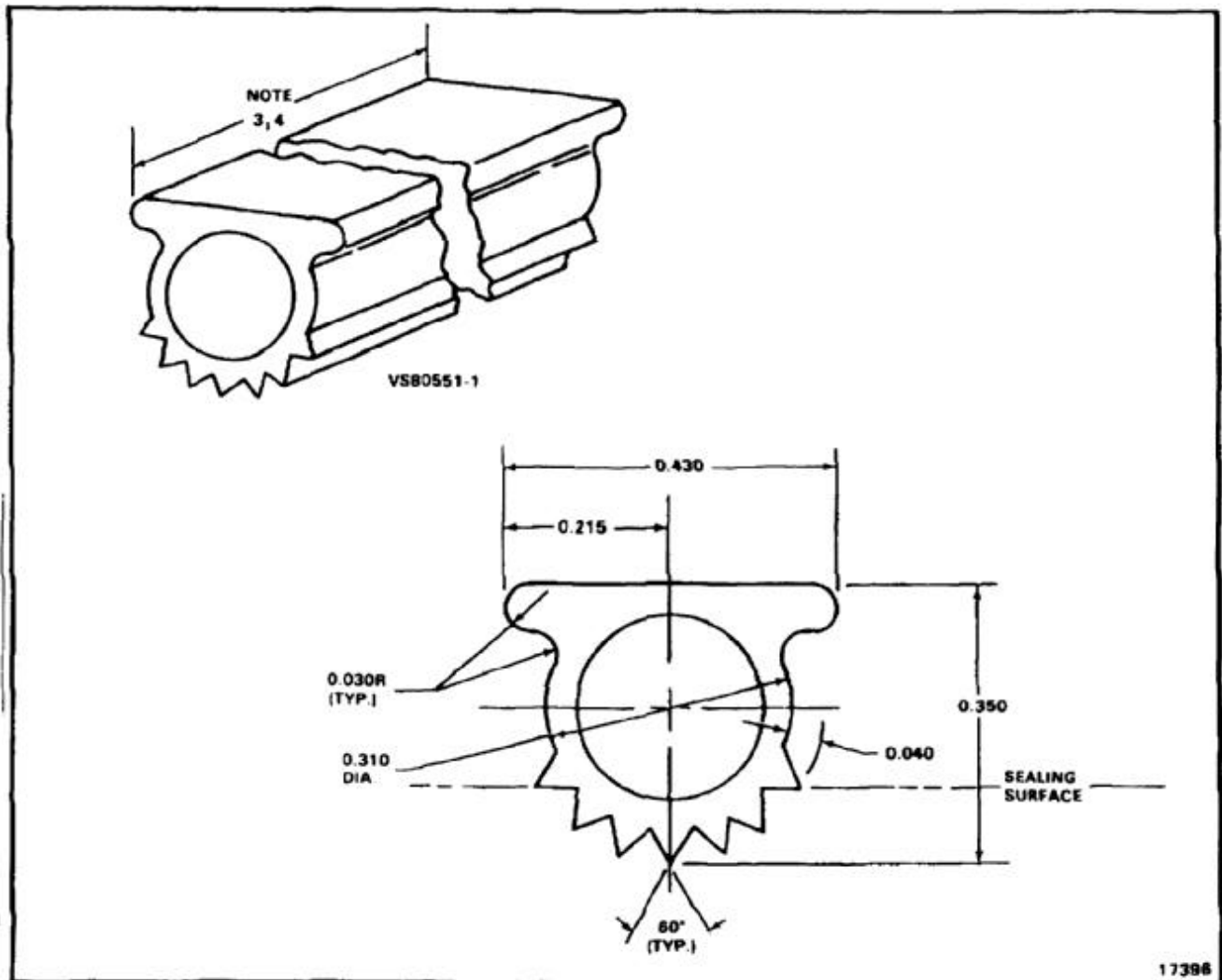

END OF TASK

NOTES:

1. MAKE FROM PLASTIC LAMINATE AS REQUIRED BY MIL-P-25518, TYPE L.
2. ALL DIMENSIONS IN INCHES.
3. USE OLD COVER FOR TEMPLATE TO DETERMINE A, B, C, D, E, F, G, AND J DIMENSIONS.
4. USE OLD COVER FOR TEMPLATE TO DETERMINE HOLE SIZE E.
5. USE OLD COVER FOR TEMPLATE TO DETERMINE BEND RADIUS K.
6. FINISH AS REQUIRED.

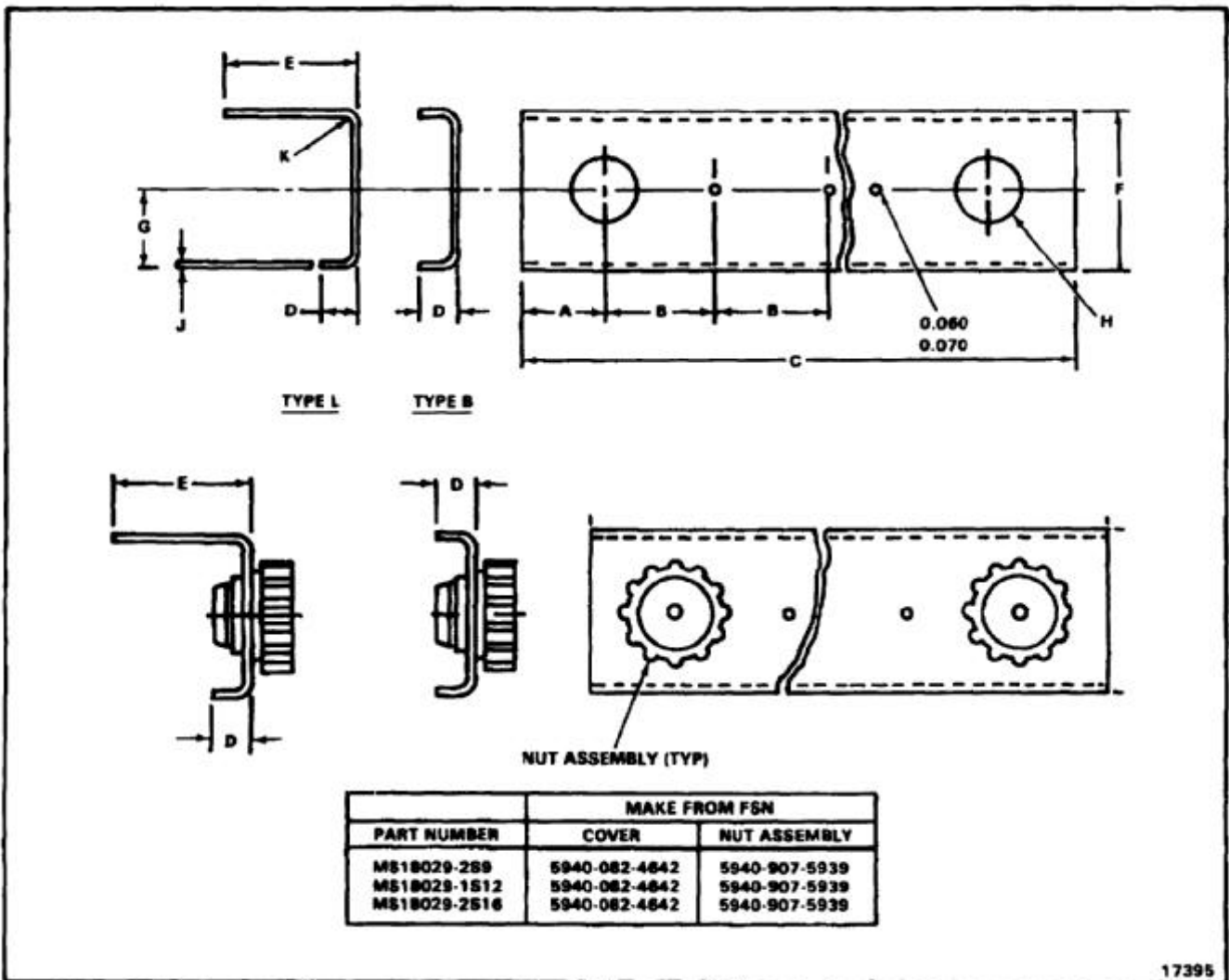

17395

END OF TASK

E-250

NOTES:

1. FABRICATE FROM ALUMINUM ALLOY SHEET
CLAD 2024-T3 PER QQ-A-250/5.
2. ALL DIMENSIONS IN INCHES.
3. STOCK SIZE 0.063 X 1.8 X 2.8.
4. USE OLD SPACER FOR TEMPLATE TO
DETERMINE EXACT DIMENSIONS.
5. FINISH AS REQUIRED.

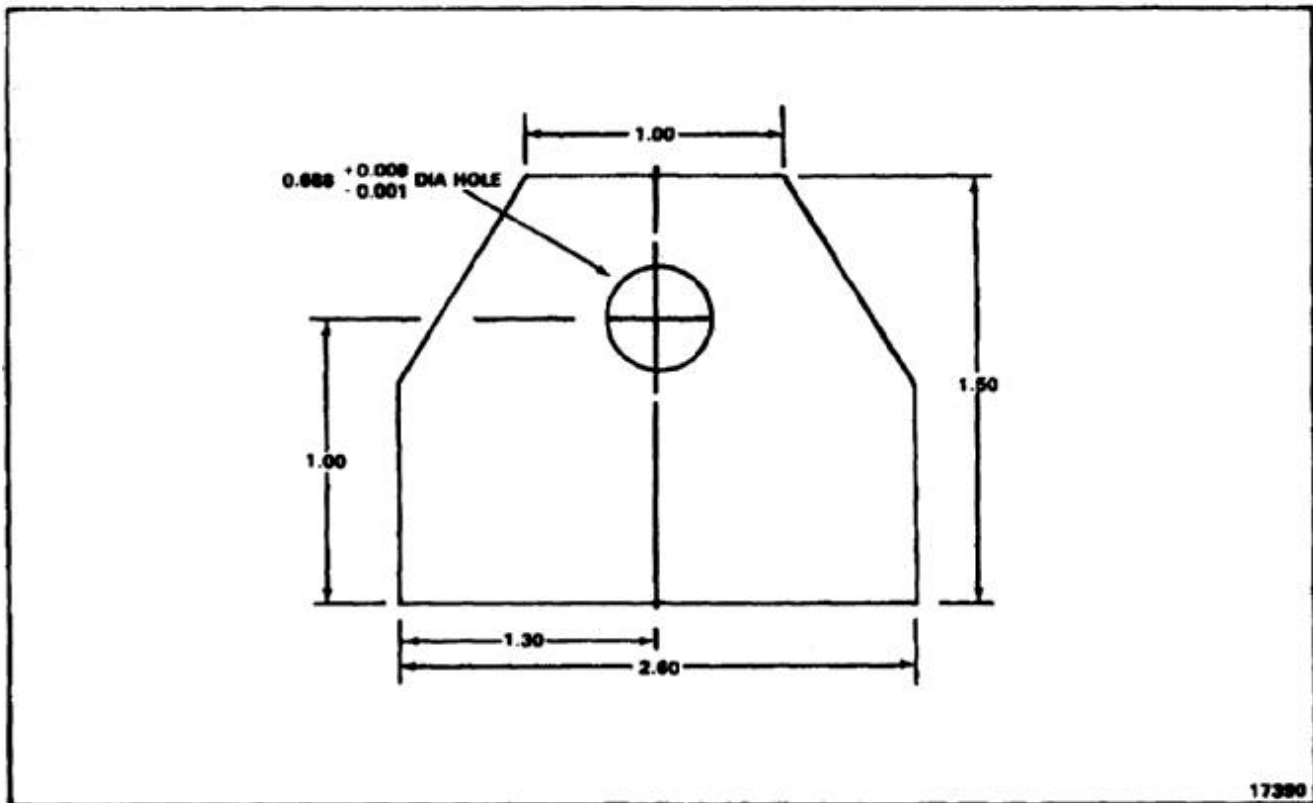

END OF TASK

NOTES:

1. -15 TYPE HALF HINGE IS MADE FROM MS2000 1PX12-100.
2. -16 TYPE HALF HINGE IS MADE FROM MS2000 1PX12-190.
3. TYPE X HALF HINGE MATES WITH TYPE Y HALF HINGE.
4. ALL DIMENSIONS IN INCHES.
5. FINISH AS REQUIRED.

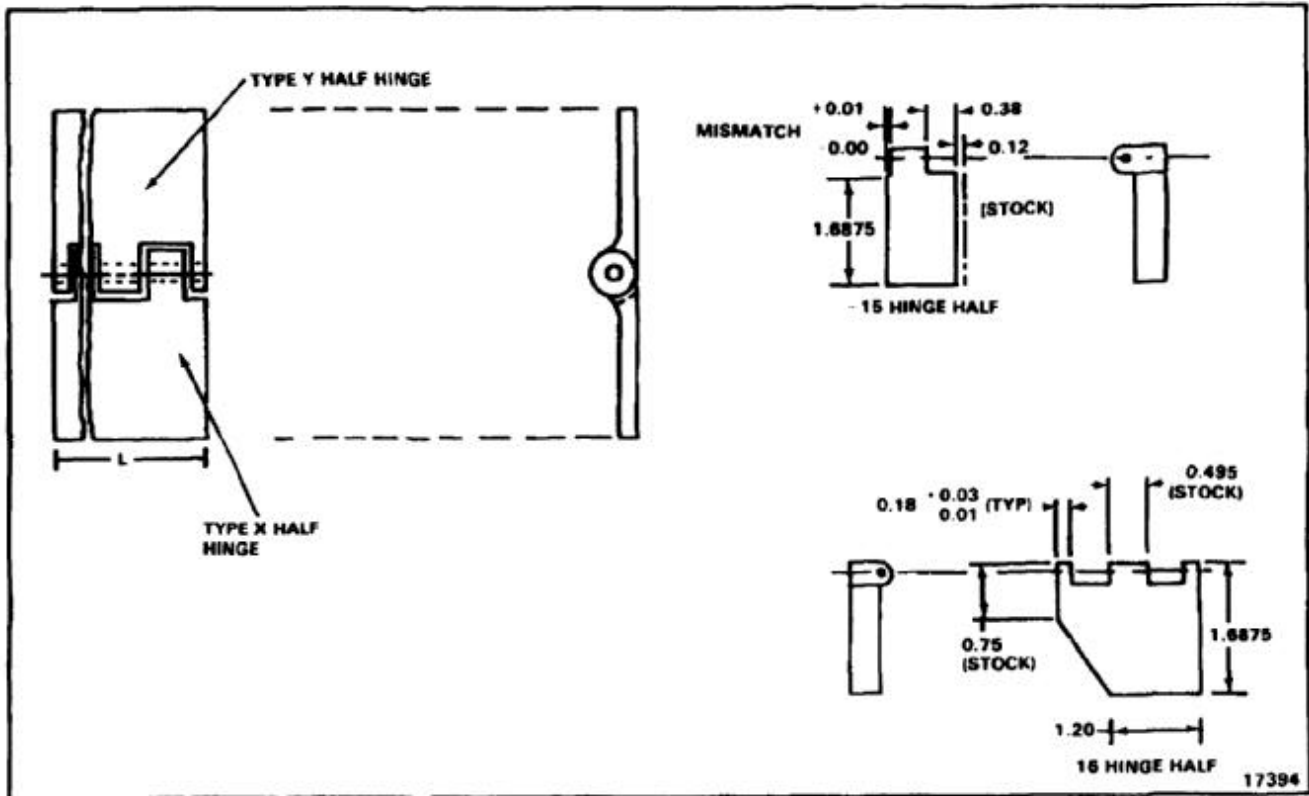

END OF TASK

NOTES:

1. FABRICATE FROM ALUMINUM ALLOY CLAD SHEET 2024-T3 PER QQ-A-250/5.
2. ALL DIMENSIONS IN INCHES.
3. STOCK 0.040 X 4.00 X 7.00.
4. FINISH AS REQUIRED.

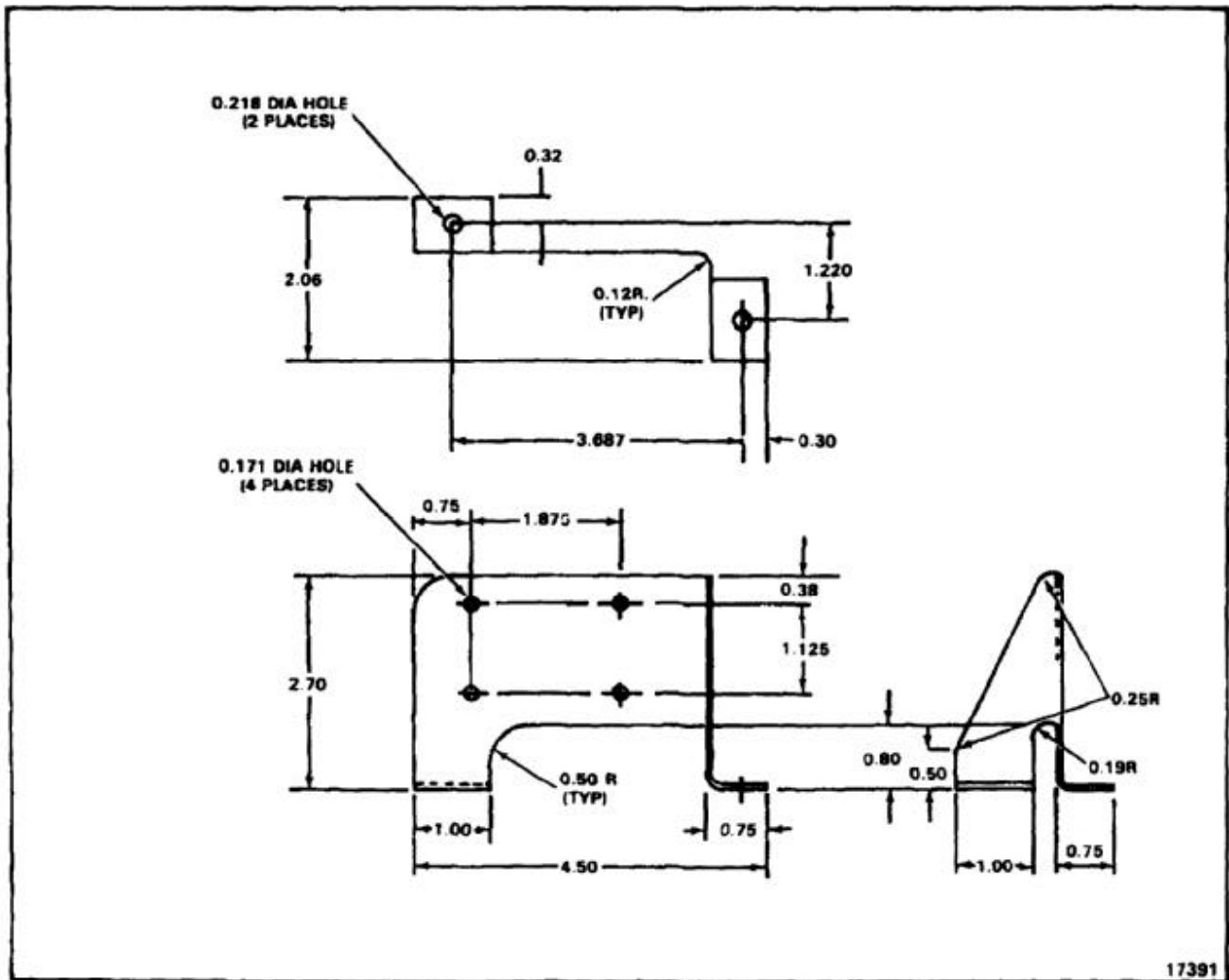

END OF TASK

NOTES:

1. FABRICATE FROM ALUMINUM ALLOY CLAD SHEET 2024-T3 PER QQ-A-250/5.
2. ALL DIMENSIONS IN INCHES.
3. STOCK 0.032 X 2.75 X 6.00.
4. FINISH PS362.

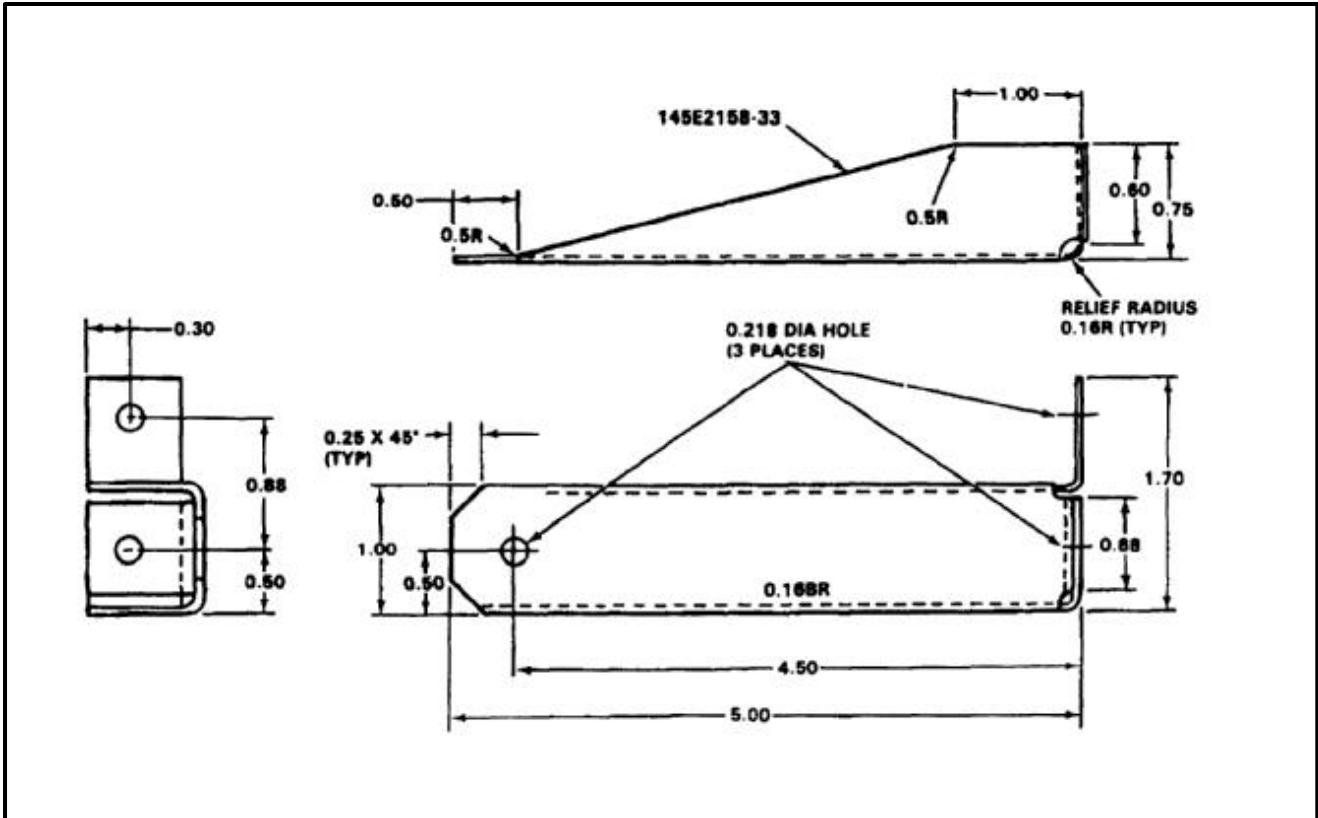

END OF TASK

NOTES:

1. FABRICATE FROM SHEET ALUMINUM ALLOY 6061-T6 PER QQ-A-250/11 TEMP T6.
2. ALL DIMENSIONS IN INCHES.
3. FINISH WITH ZINC CHROMATE PRIMER (E291).

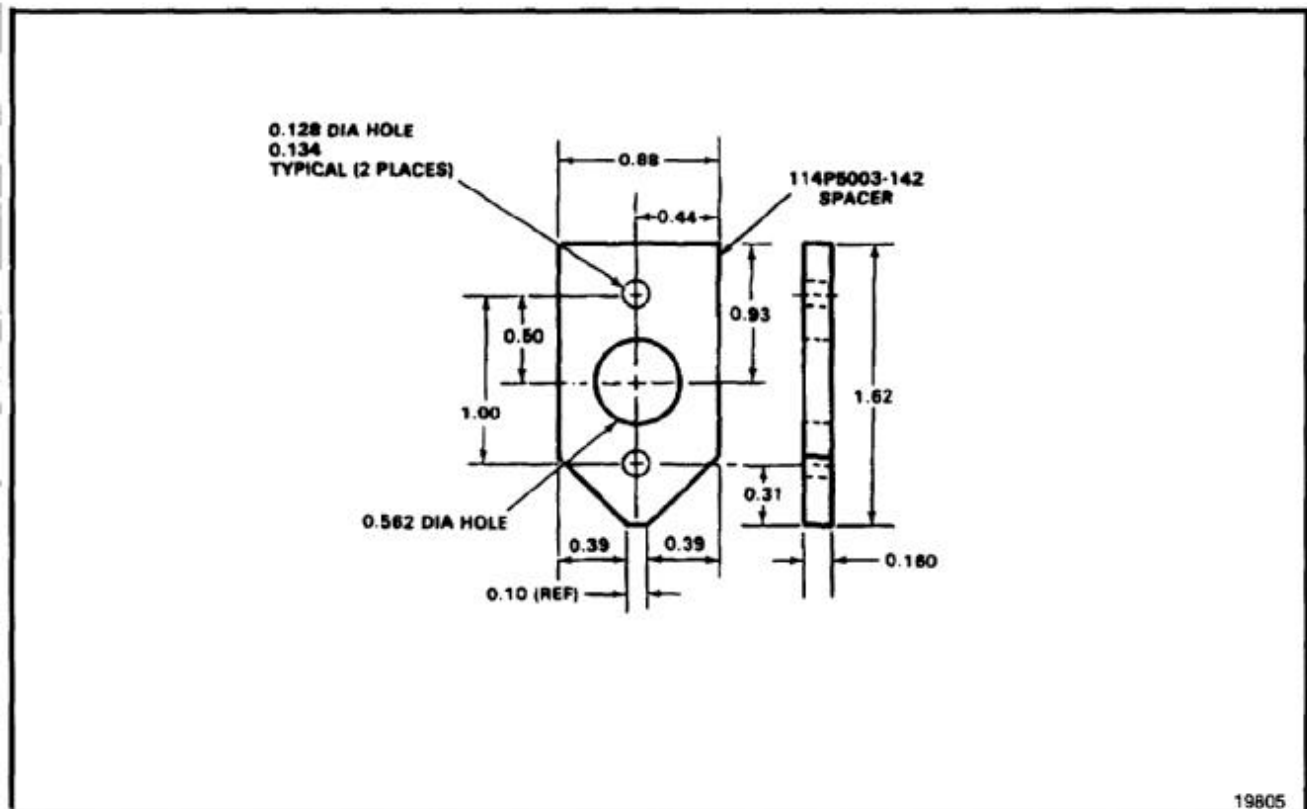

END OF TASK

NOTES:

1. FABRICATE FROM 2024-T4 CLAD ALUMINUM ALLOY SHEET QQ-A-250/5.
2. ALL DIMENSIONS IN INCHES.
3. STOCK SIZE 0.032 X 3.3 X 4.5.
4. FINISH WITH ZINC CHROMATE PRIMER (E291).

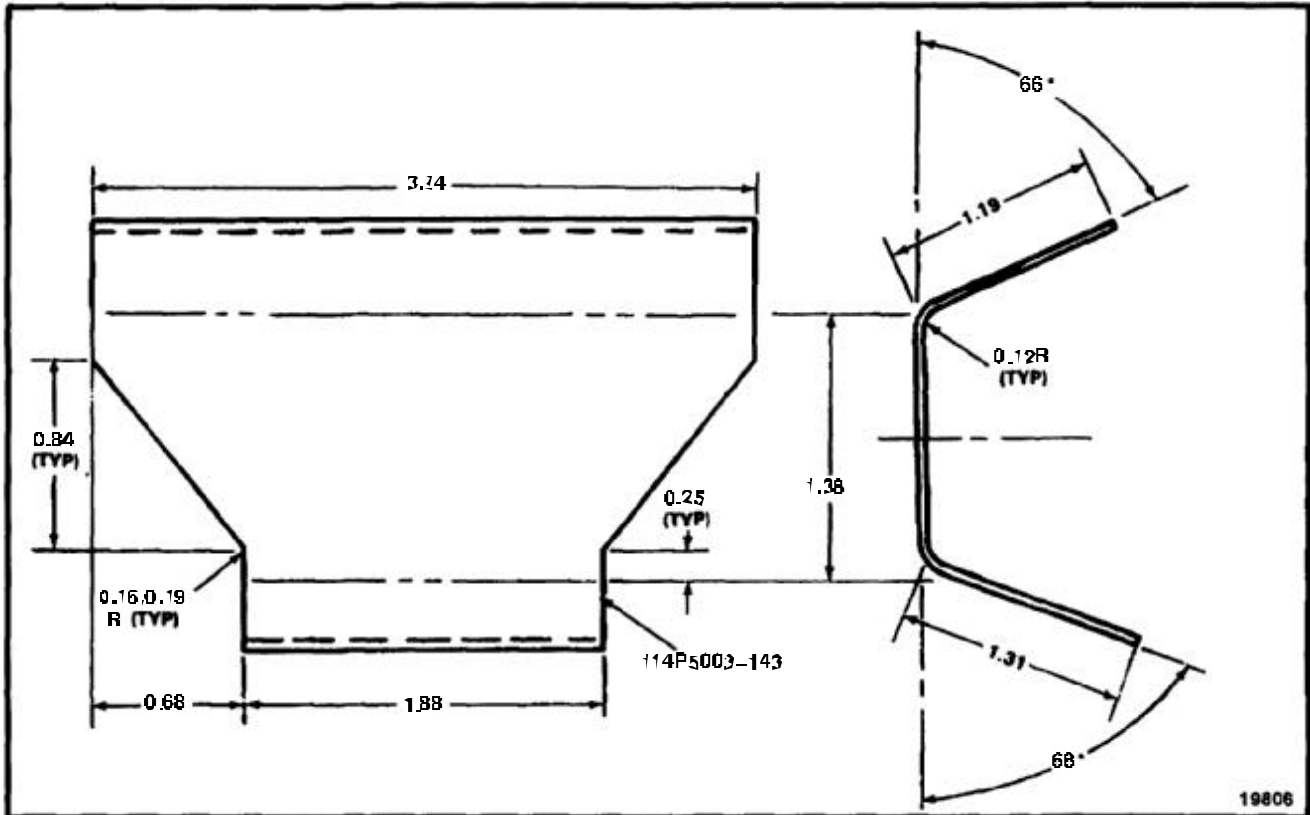

END OF TASK

NOTES:

1. FABRICATE FROM 2024-T4 CLAD ALUMINUM ALLOY SHEET QQ-A-250/5.
2. ALL DIMENSIONS IN INCHES.
3. STOCK SIZE 0.032 X 2.6 X 4.6.
4. FINISH WITH ZINC CHROMATE PRIMER (E291).

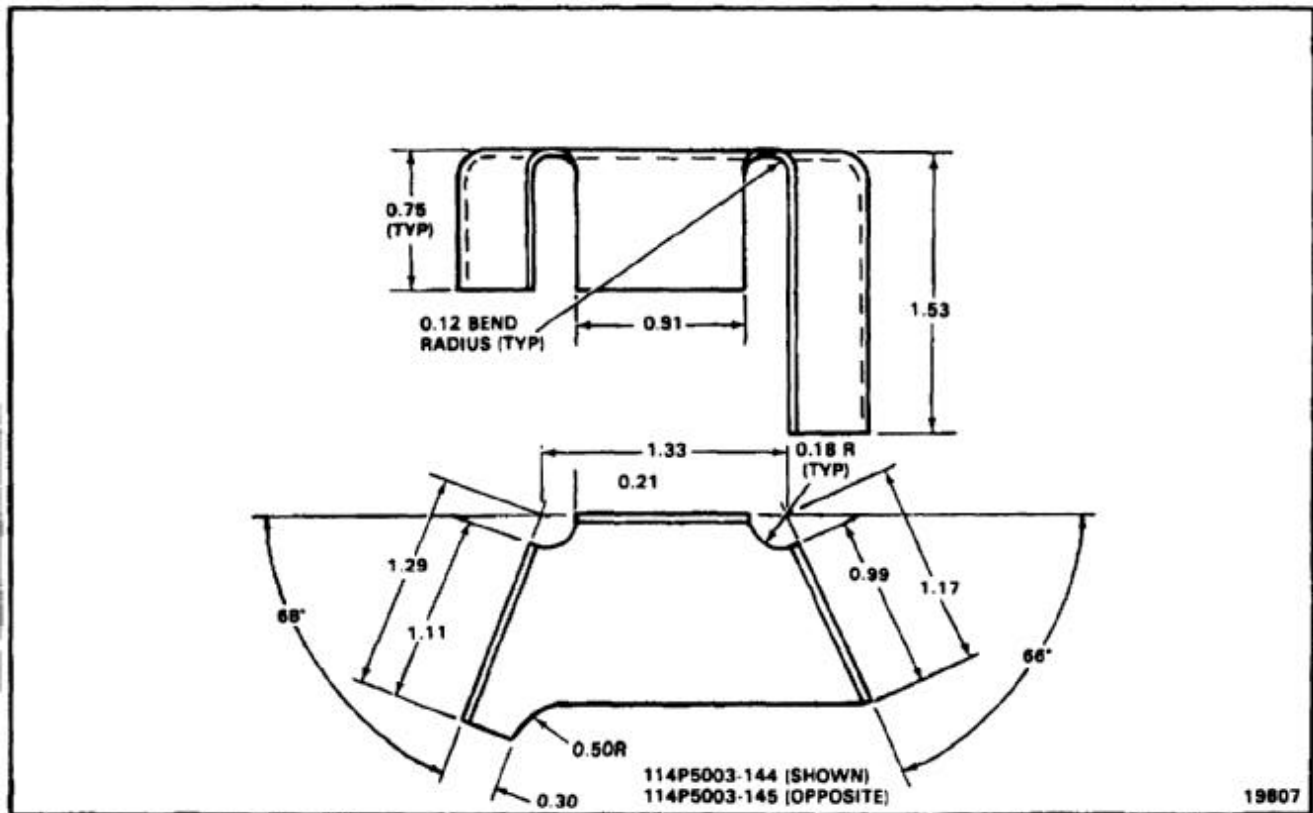

END OF TASK

NOTES:

1. FABRICATE FROM MS20001PX4-10.09.
2. USE FAIRING ASSEMBLY TO LOCATE RIVET HOLES.
3. FINISH ALL CUT EDGES WITH ZINC CHROMATE PRIMER (E291).

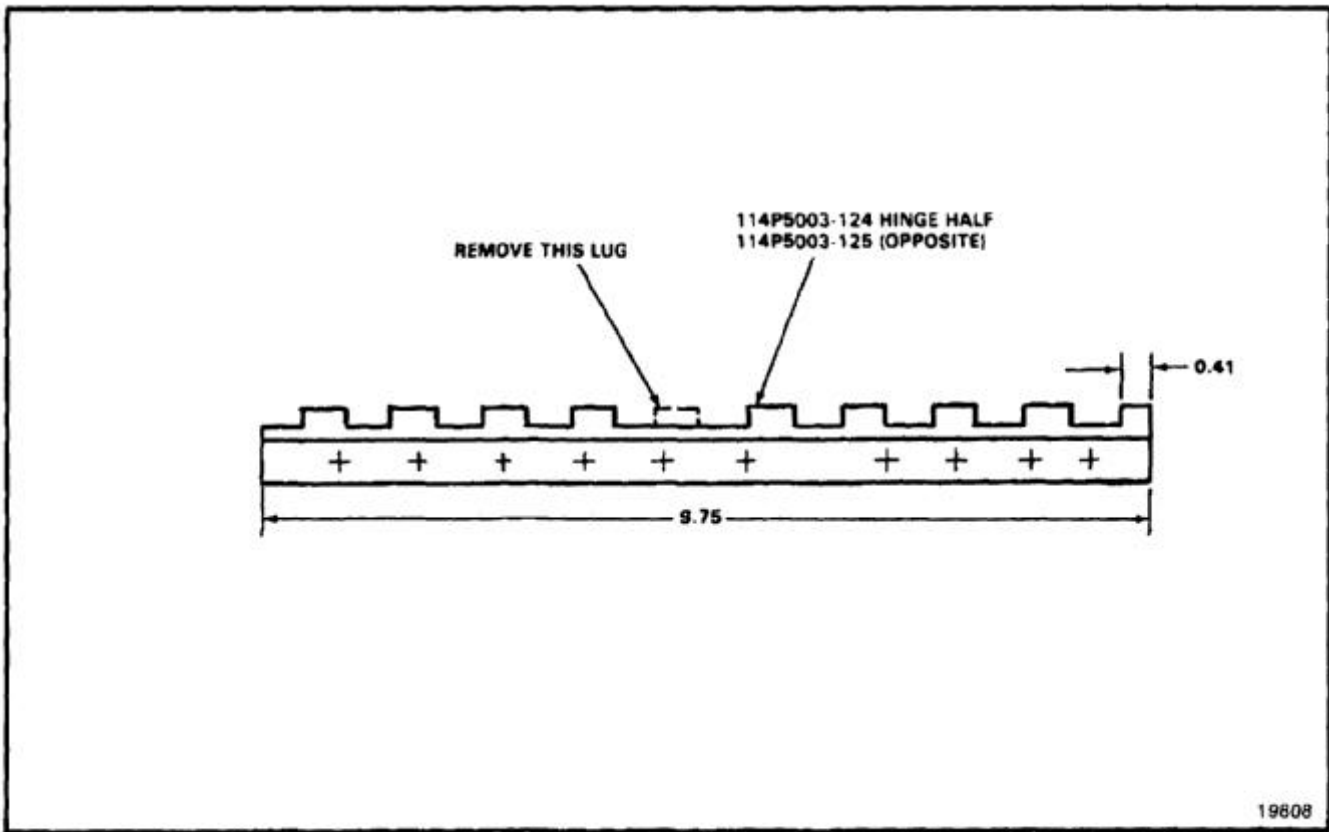

END OF TASK

NOTES:

1. FABRICATE FROM MS20001PX4-10.09.
2. USE FAIRING ASSEMBLY TO LOCATE RIVET HOLES.
3. FINISH ALL CUT EDGES WITH ZINC CHROMATE (E291).

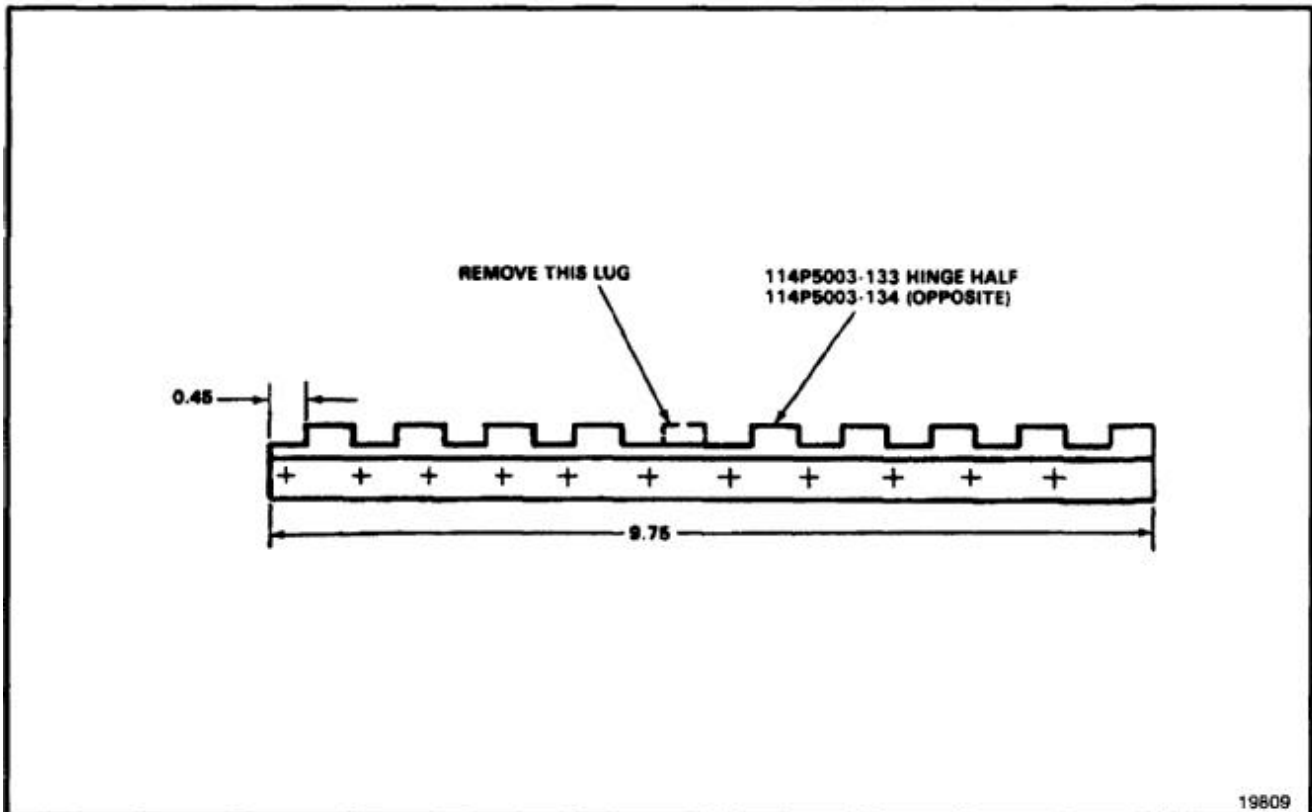

END OF TASK

NOTES:

1. FABRICATE FROM MS20253P2-943.
2. ALL DIMENSION IN INCHES.

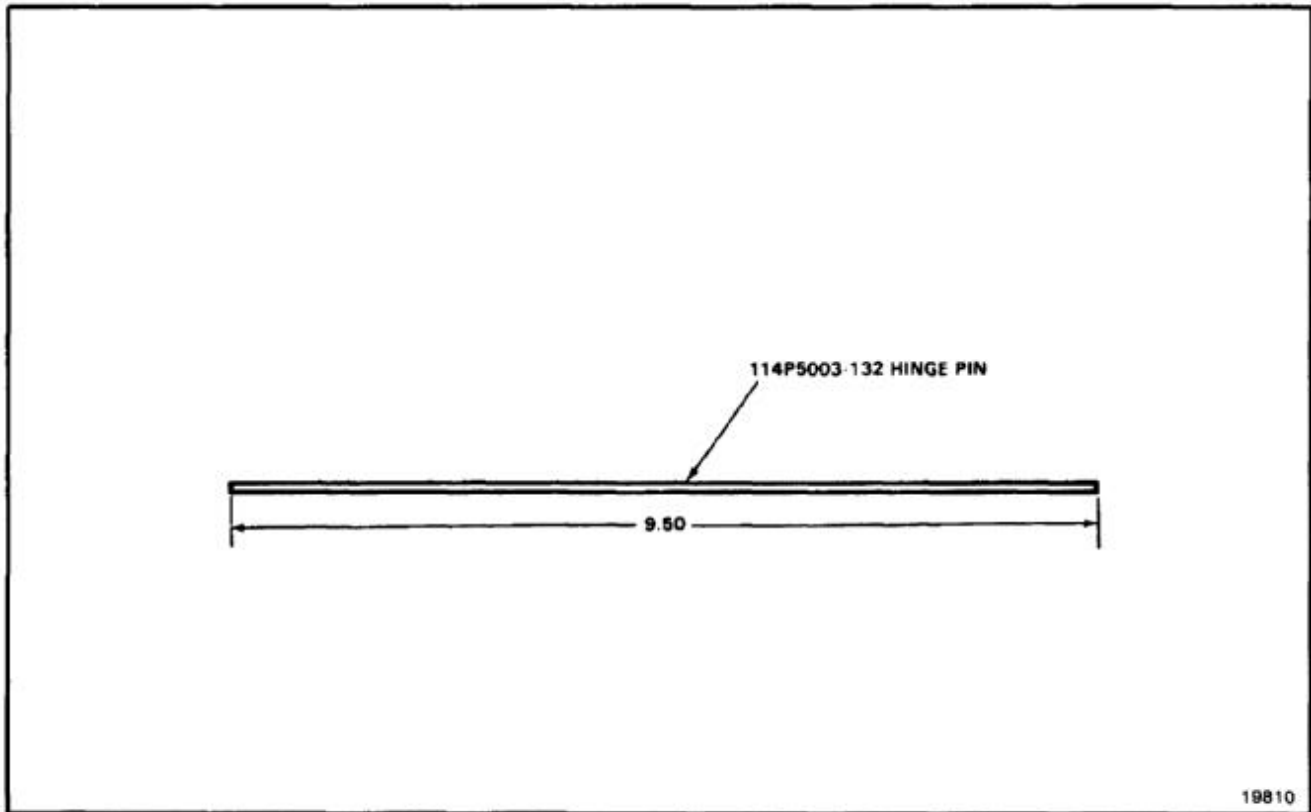

END OF TASK

NOTES:

1. FABRICATE FROM PD70 TUBING. (RAYCHEM CO., MENLO PARK, CA 94025.)
2. STOCK SIZE 0.018 ID X 0.87 LONG.
3. ALL DIMENSIONS IN INCHES.

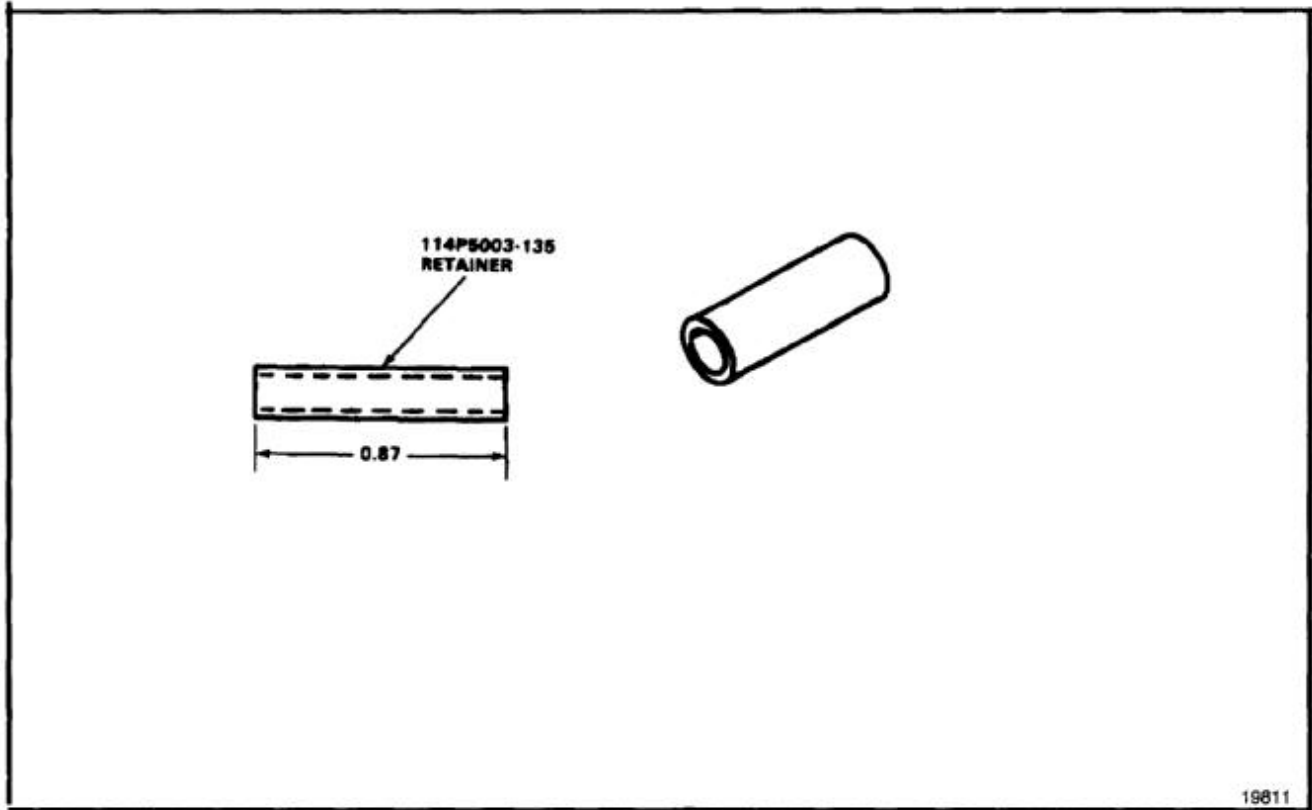

END OF TASK

NOTES:

1. FABRICATE FROM 2024-T4 ALUMINUM ALLOY CLAD SHEET QQ-A-250/5.
2. ALL DIMENSIONS IN INCHES.
3. STOCK SIZE 0.063 X 0.8 X 2.3.
4. FINISH WITH ZINC CHROMATE PRIMER (E291).

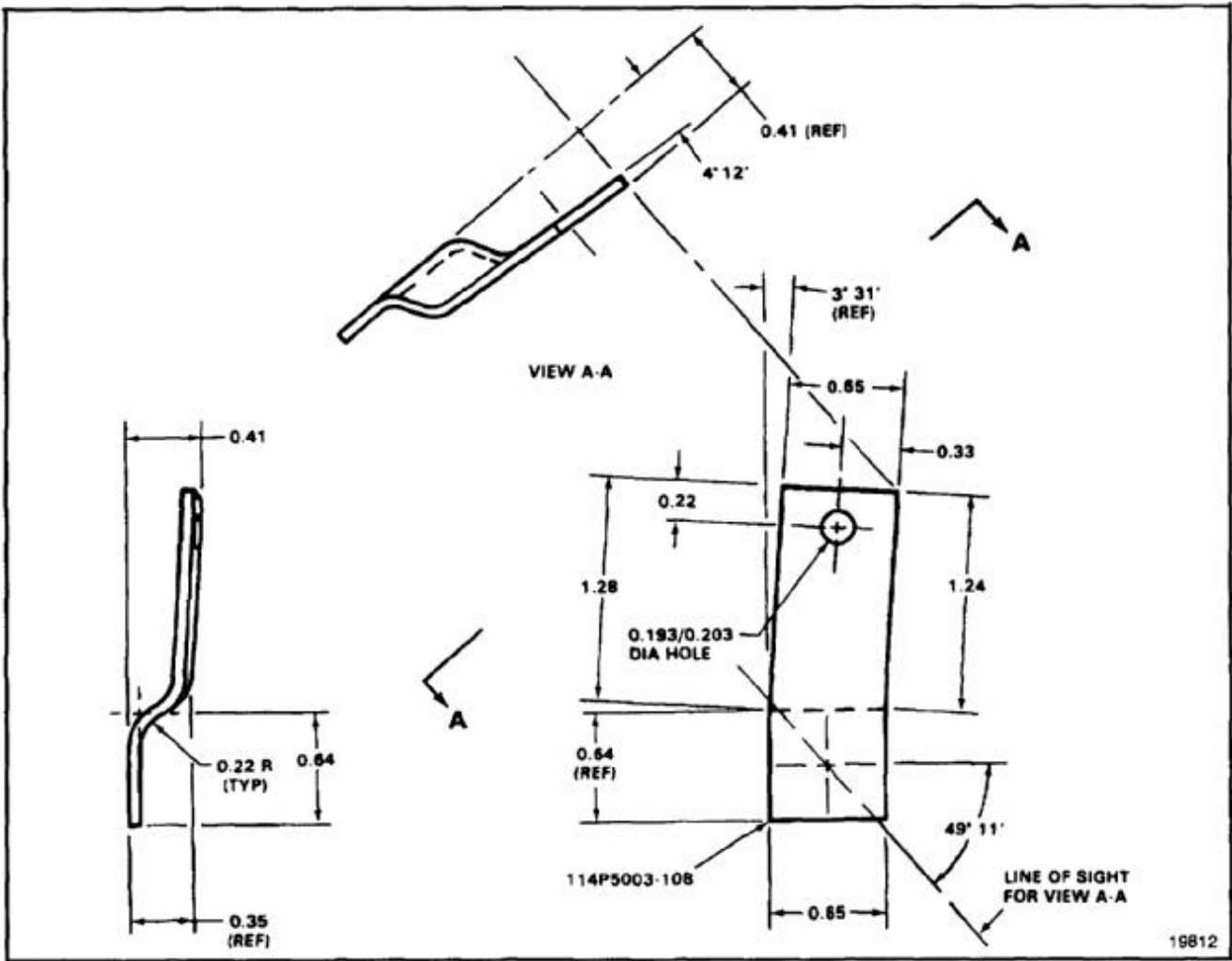

END OF TASK

NOTES:

1. FABRICATE FROM 2024-T4 ALUMINUM ALLOY CLAD SHEET QQ-A-250/5.
2. STOCK SIZE 0.040 X 1.3 X 2.4.
3. ALL DIMENSIONS IN INCHES.
4. USE FAIRING ASSEMBLY TO LOCATE RIVET HOLES.
5. FINISH WITH ZINC CHROMATE PRIMER (E291).

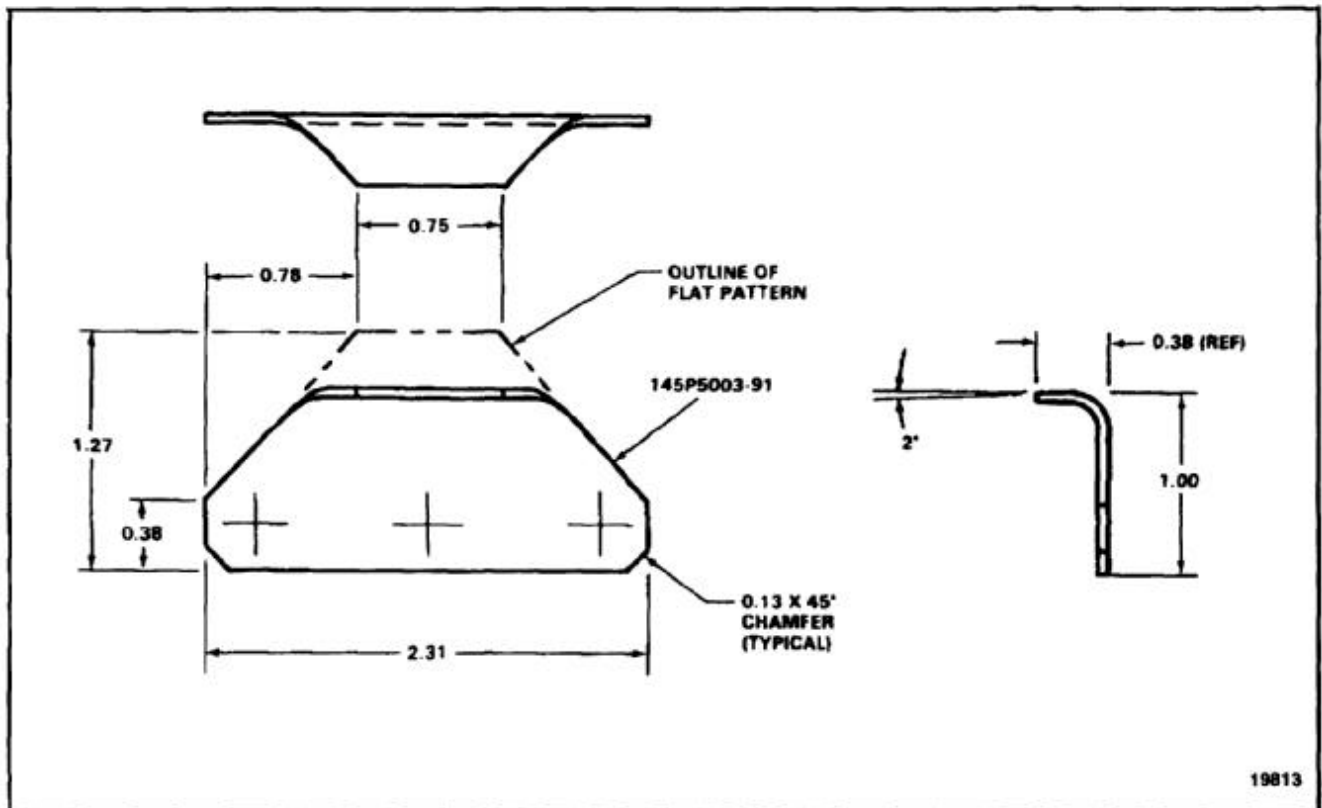

END OF TASK

NOTES:

1. FABRICATE FROM ALUMINUM ALLOY SHEET 6061-T6 PER QQ-A-250/11.
2. STOCK SIZE 0.100 X 0.4 X 0.8.
3. USE FAIRING ASSEMBLY TO LOCATE RIVET HOLES.
4. FINISH WITH ZINC CHROMATE PRIMER (E291).
5. ALL DIMENSIONS IN INCHES.

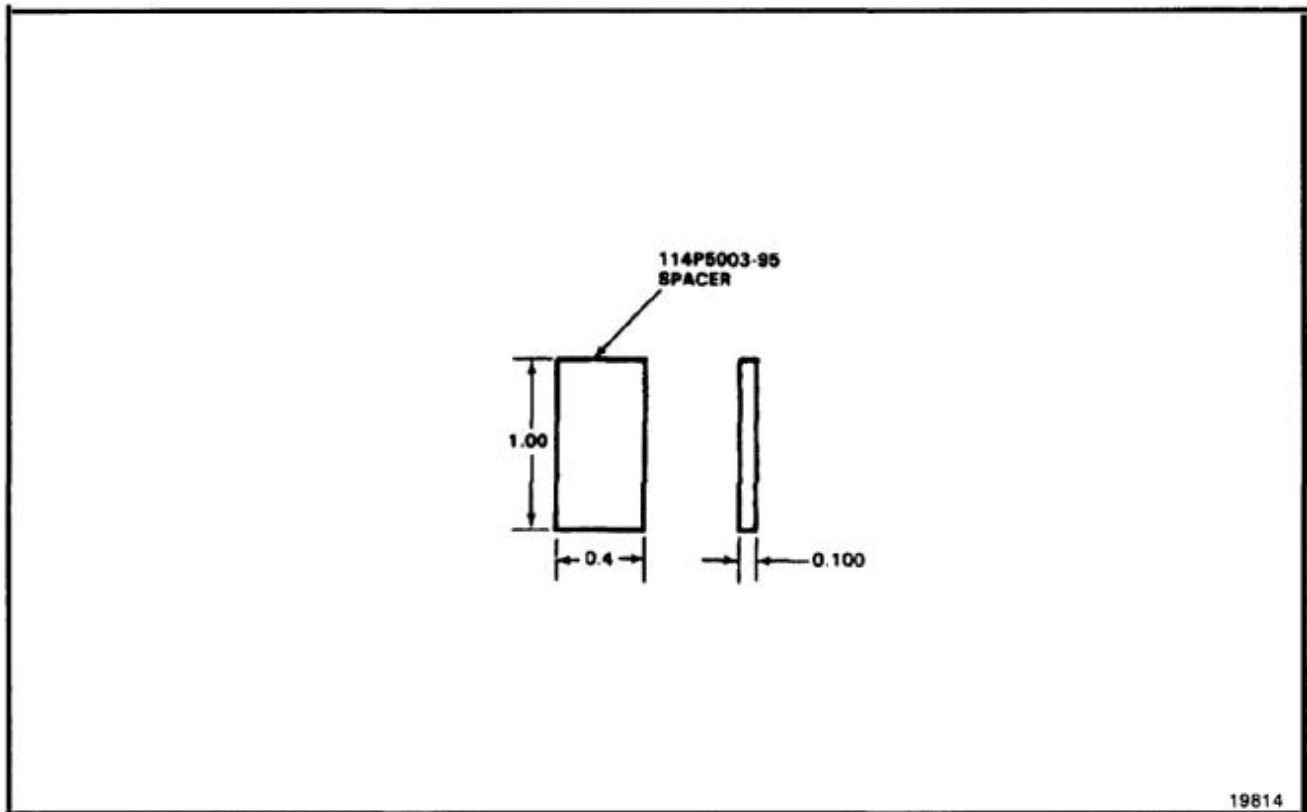

END OF TASK

E-264

NOTES:

1. FABRICATE FROM AMS3195 SILICONE RUBBER SPONGE SHEET.
2. STOCK SIZE 0.12 X 0.87 WIDE.
3. ALL DIMENSIONS IN INCHES.
4. TWO REQUIRED FOR EACH INSTALLATION BETWEEN WINDSHIELD AND STRUCTURE. USE ORIGINAL SEAL TO DETERMINE X DIMENSION.

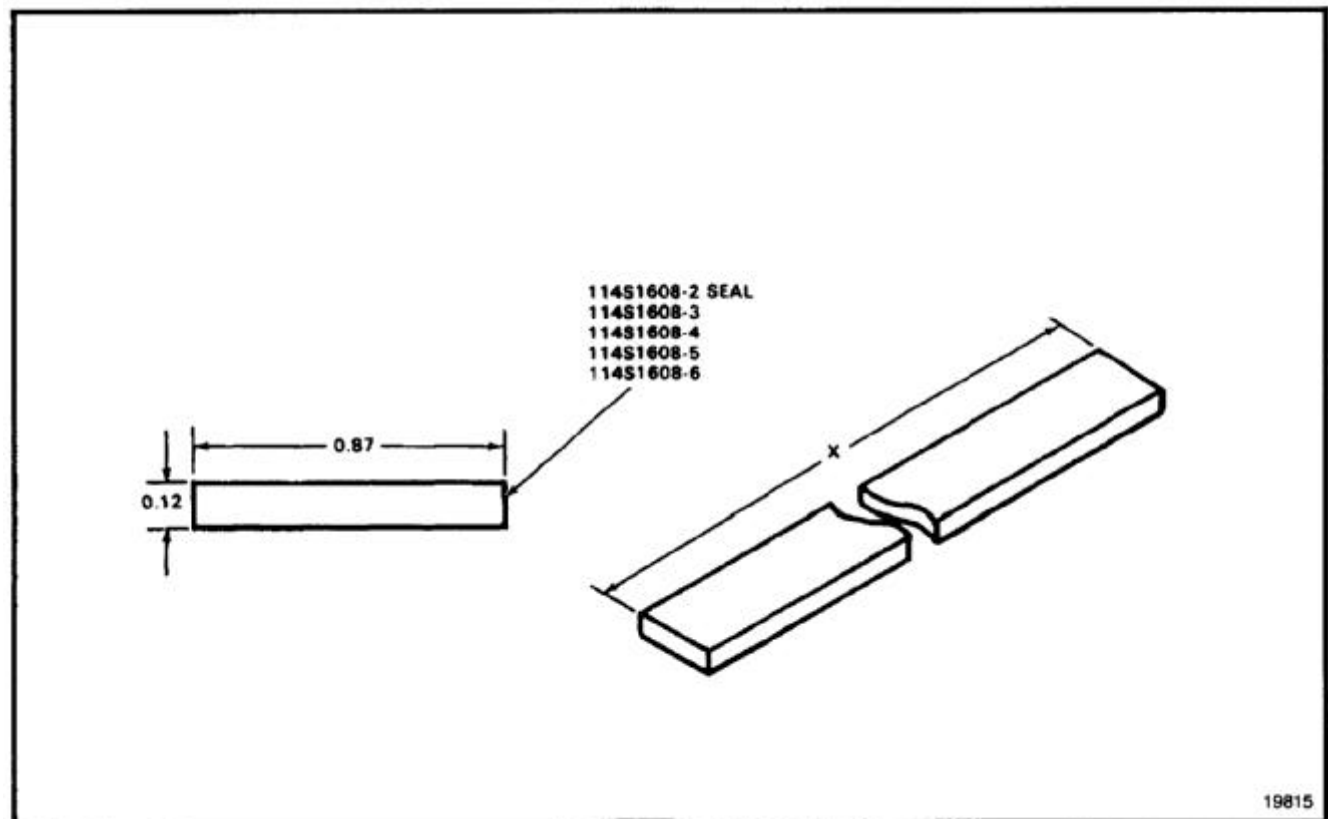

END OF TASK

NOTES:

1. FABRICATE FROM AMS3195 SILICONE RUBBER SPONGE SHEET.
2. STOCK SIZE 0.12 X 0.87 WIDE X 8.5 LONG.
3. ALL DIMENSIONS IN INCHES.
4. USE ORIGINAL SEAL TO DETERMINE DIMENSION X AND EXACT SHAPE.

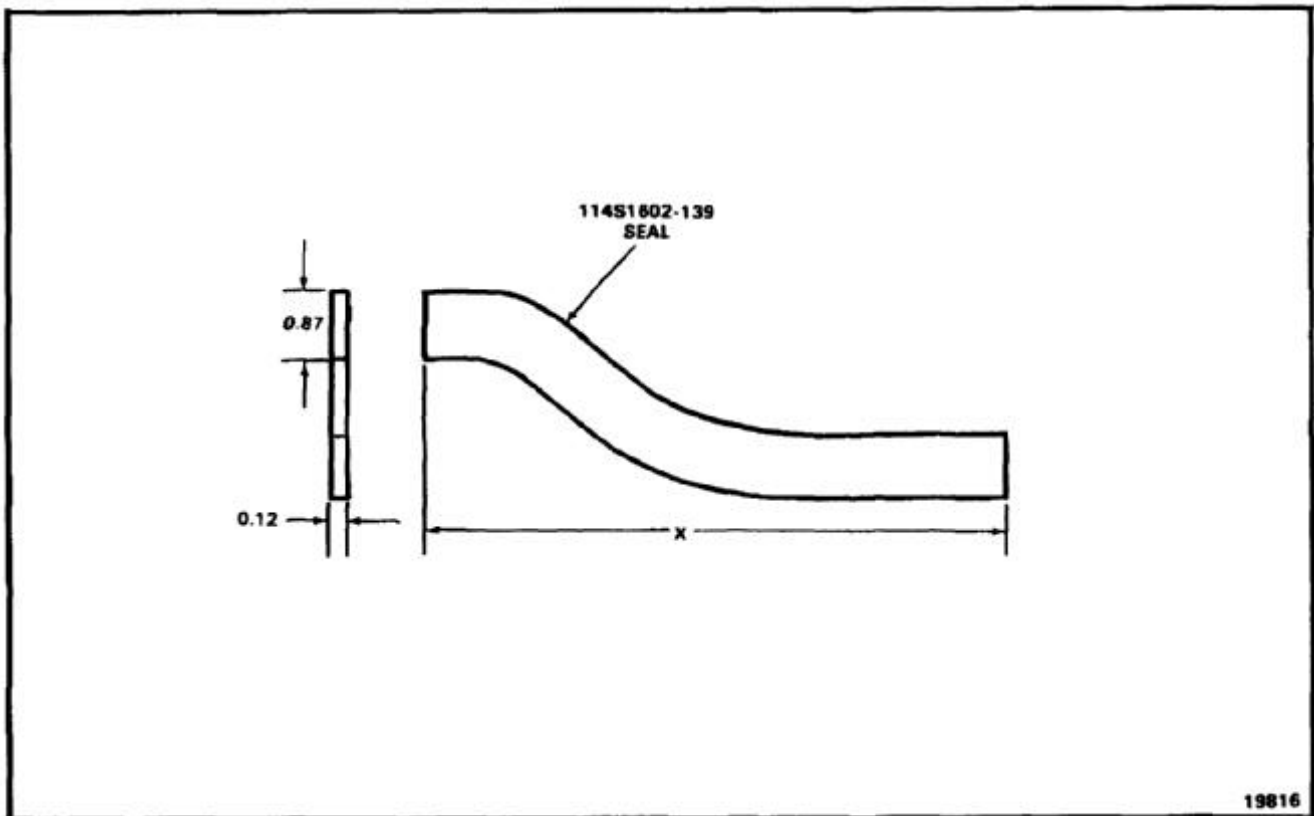

19816

END OF TASK

E-266

NOTES:

1. FABRICATE FROM ALUMINUM ALLOY CLAD SHEET 2024-T4 PER QQ-A-250/11.
2. STOCK SIZE 0.040 X 1.1 X 24.7.
3. ALL DIMENSIONS IN INCHES.
4. FINISH AS REQUIRED.

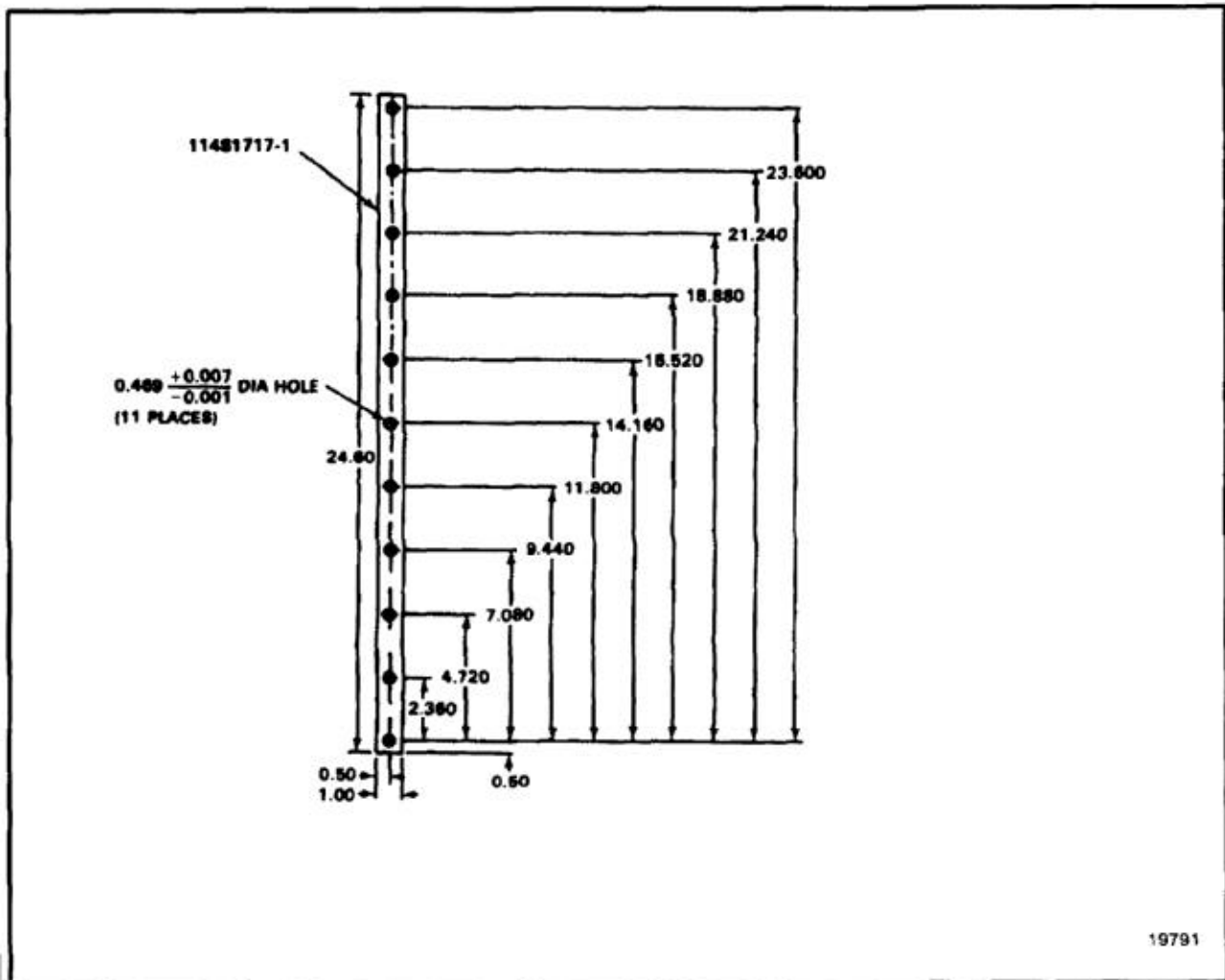

19791

END OF TASK

NOTES:

1. FABRICATE -18 FROM VELCRO PILE TAPE V-320-2(80)-100.
2. FABRICATE -19 FROM VELCRO HOOK TAPE V-320-1(80)- 100.
3. STOCK SIZES: -18: 1.6 LONG, -19: 5.2 LONG.
4. ALL DIMENSIONS IN INCHES.
5. USE ORIGINAL TAPES TO DETERMINE X AND Y DIMENSIONS.

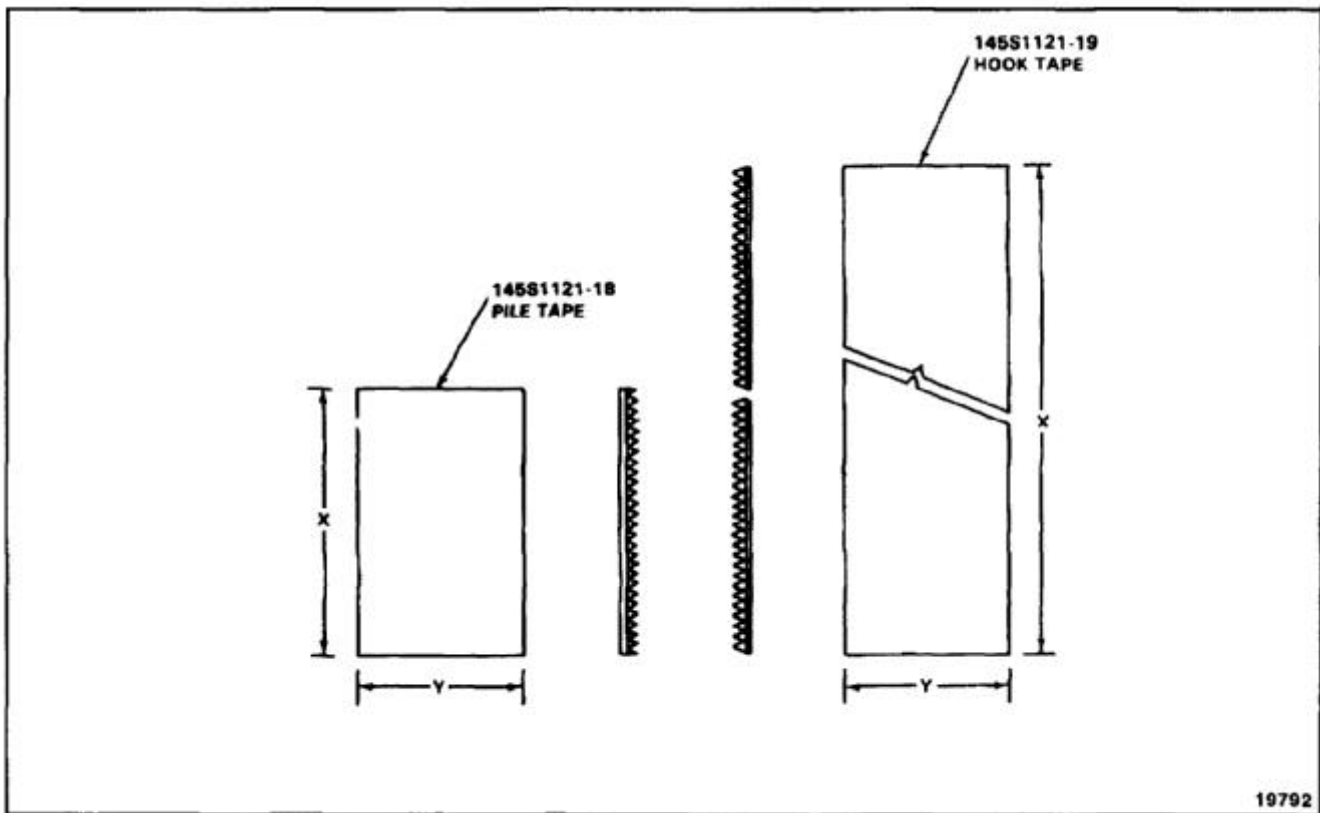

END OF TASK

NOTES:

1. FABRICATE FROM VS80540-1.
2. ALL DIMENSIONS IN INCHES.

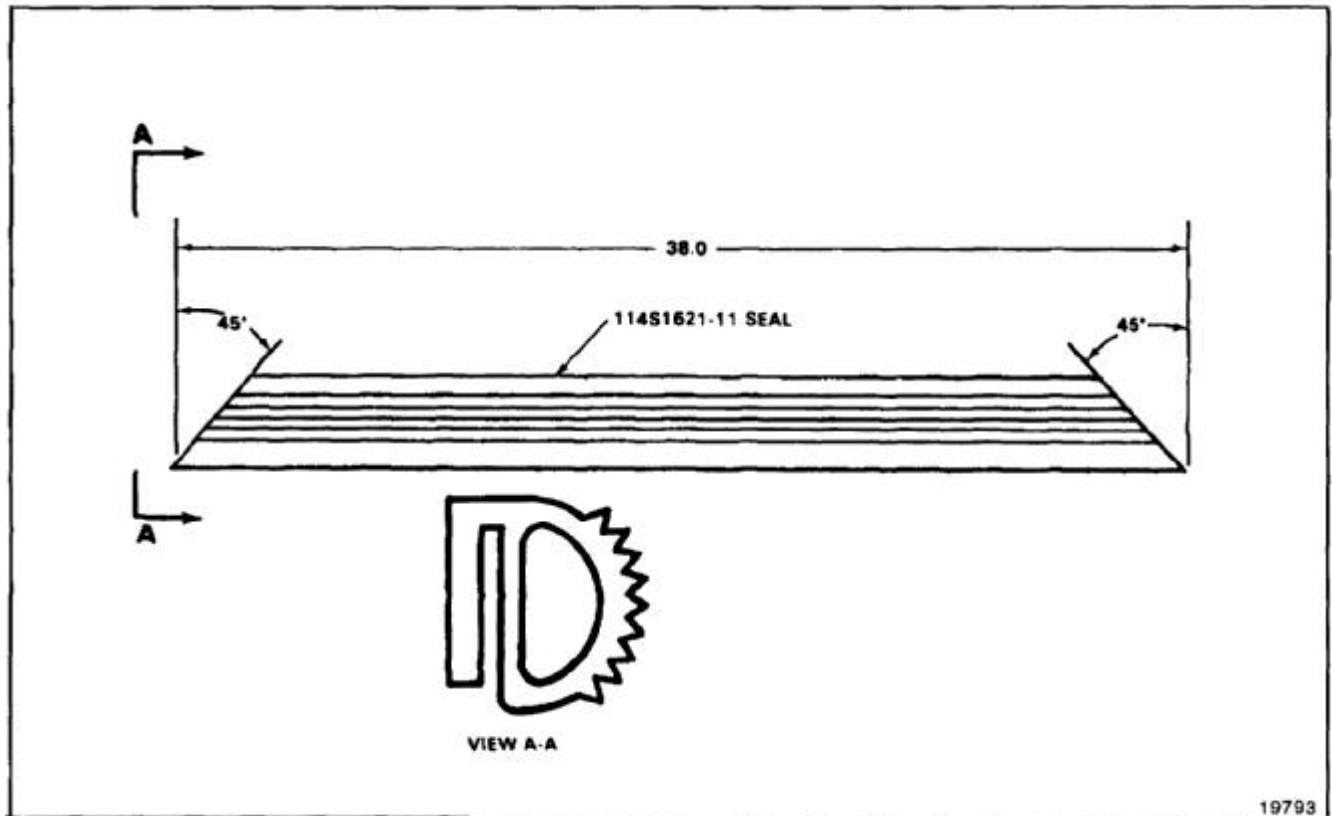

END OF TASK

NOTES:

1. FABRICATE FROM VS80567-3 (TYPE II SILICONE RUBBER SEAL MIL-R-25988).
2. USE ORIGINAL SEAL TO DETERMINE X DIMENSION.

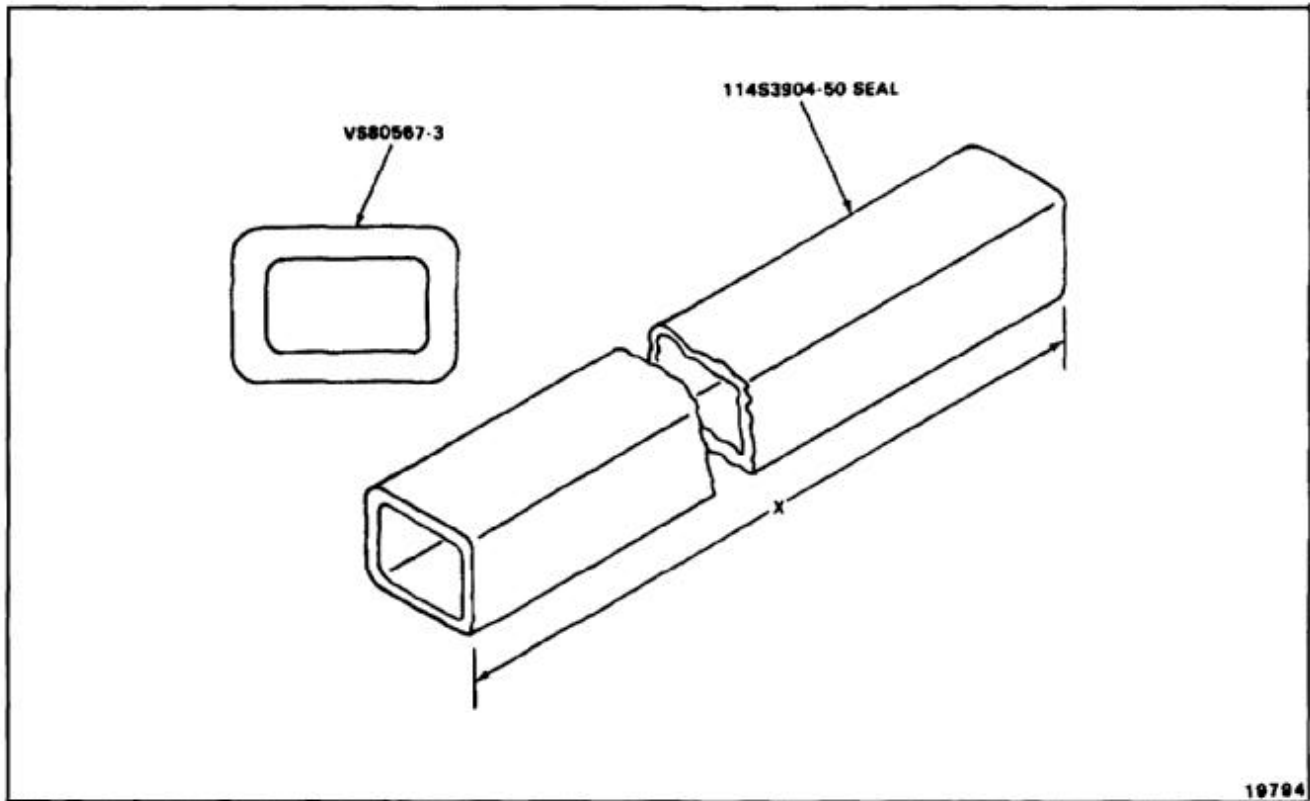

END OF TASK

E-270

NOTES:

1. FABRICATE FROM VS20101-2-2 HINGE (2024-T4 AL PER QQ-A-267, ALCOA 10573).
2. USE ORIGINAL HINGE HALF TO DETERMINE X DIMENSION AND LOCATE PILOT HOLES.

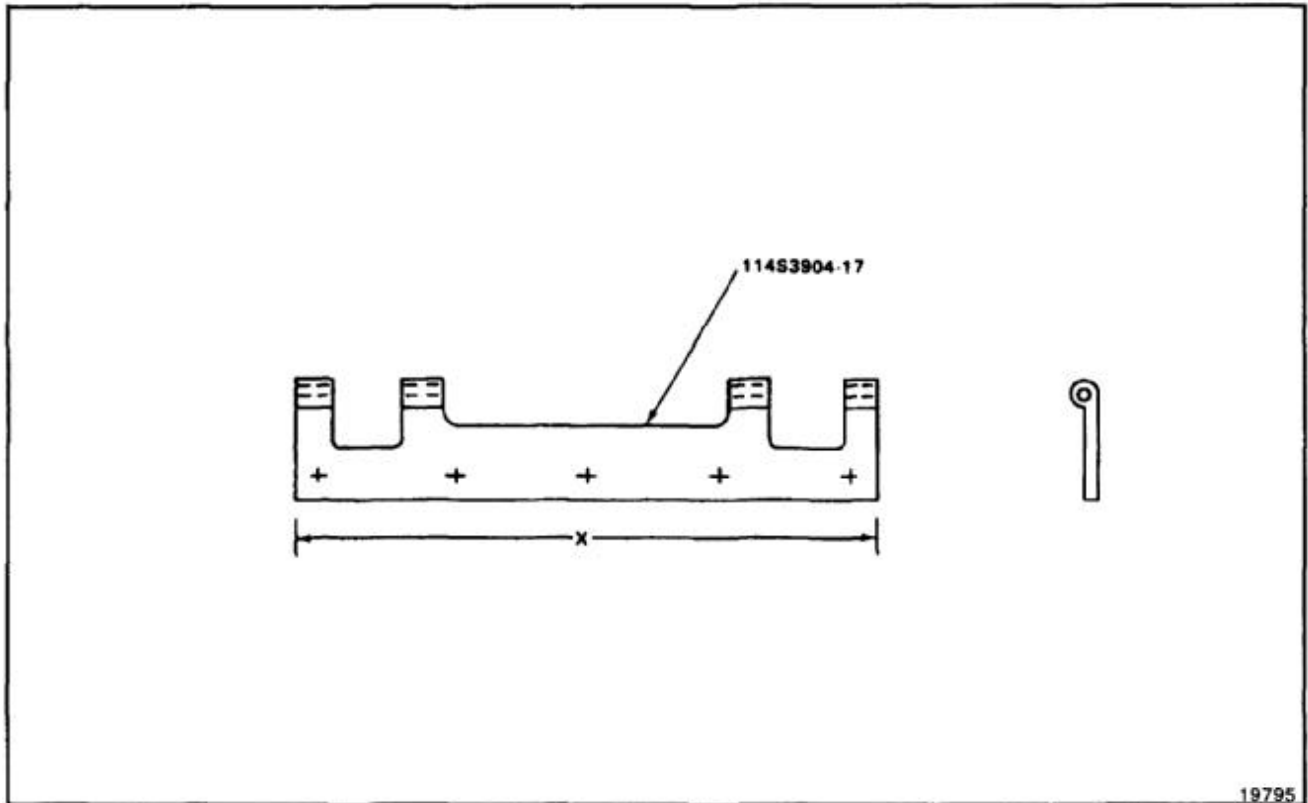

END OF TASK

NOTES:

1. FABRICATE FROM ALUMINUM ALLOY BARE SHEET 7075-T6 PER QQ-A-250/12.
2. STOCK SIZE 0.125 X 0.9 X 3.3.
3. ALL DIMENSIONS IN INCHES.
4. USE ORIGINAL RADIUS BLOCK TO DETERMINE X AND Y DIMENSIONS.

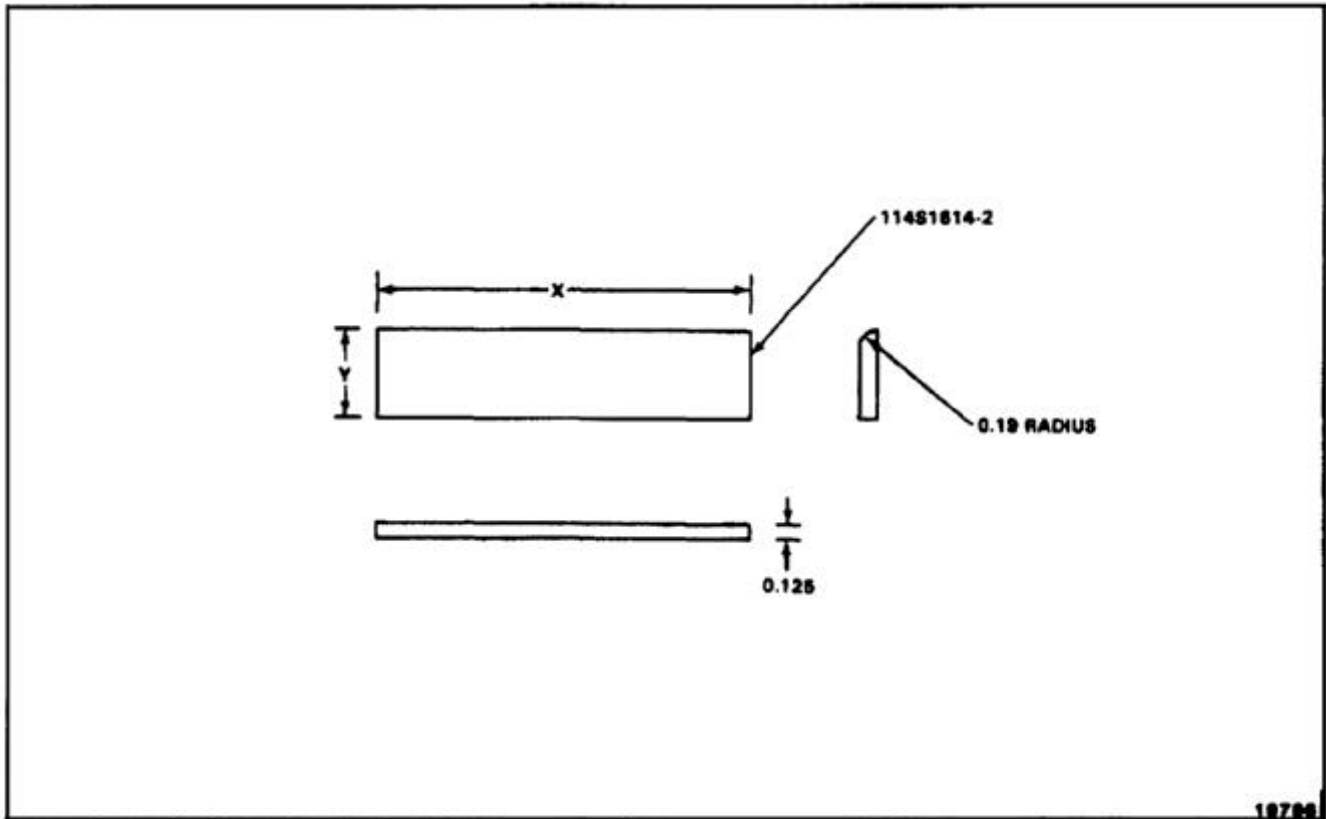

END OF TASK

E-272

NOTES:

1. FABRICATE FROM ALUMINUM ALLOY SHEET 2024-T3 PER QQ-A-250/5.
2. STOCK SIZE 0.040 X 3.2 X 4.3.
3. ALL DIMENSIONS IN INCHES.
4. USE ORIGINAL PLATE TO DETERMINE DIMENSION X.
5. FINISH AS REQUIRED.

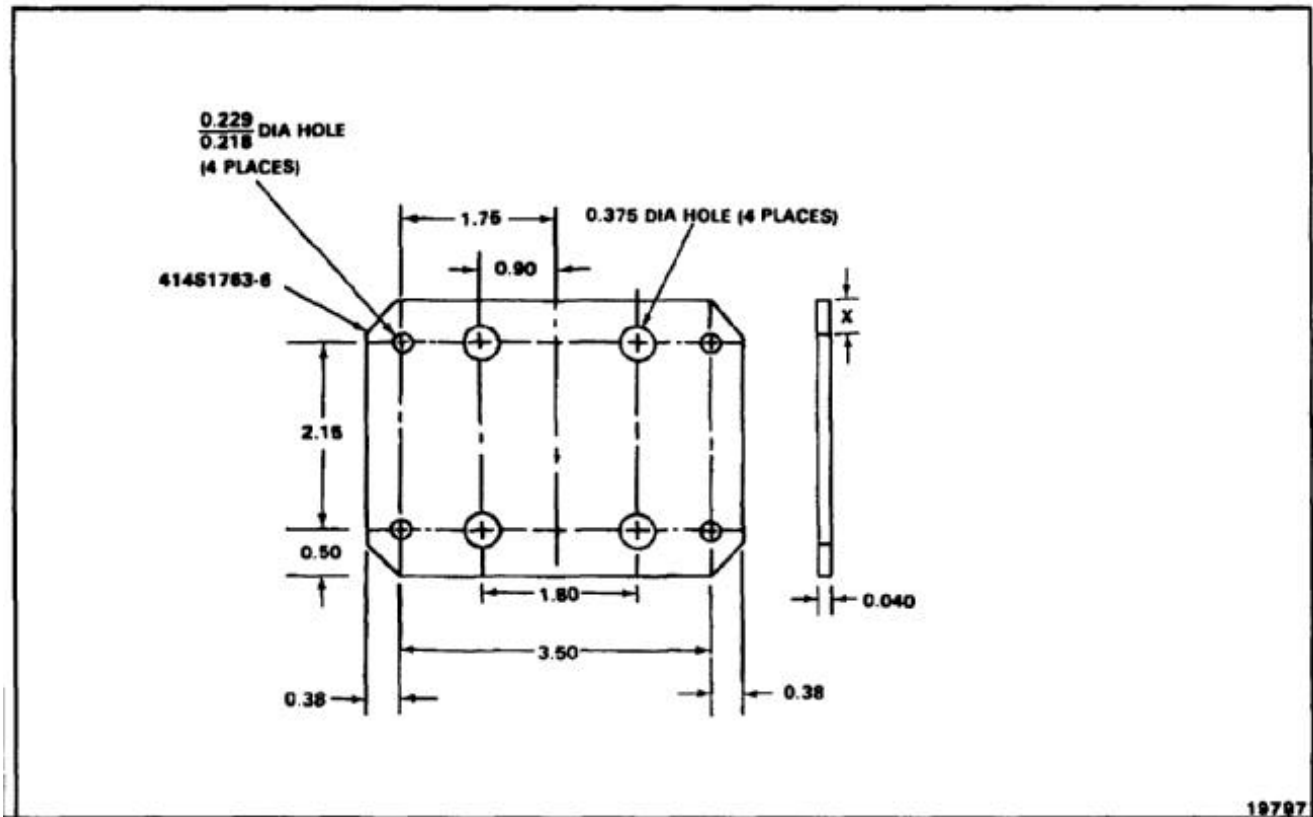

END OF TASK

NOTES:

1. FABRICATE FROM ALUMINUM ALLOY SHEET 2024-T3 PER QQ-A-250/5.
2. STOCK SIZE 0.040 X 2.3 X 4.5.
3. ALL DIMENSIONS IN INCHES.
4. USE ORIGINAL ANGLE TO DETERMINE HOLE LOCATIONS AND DIMENSION X.

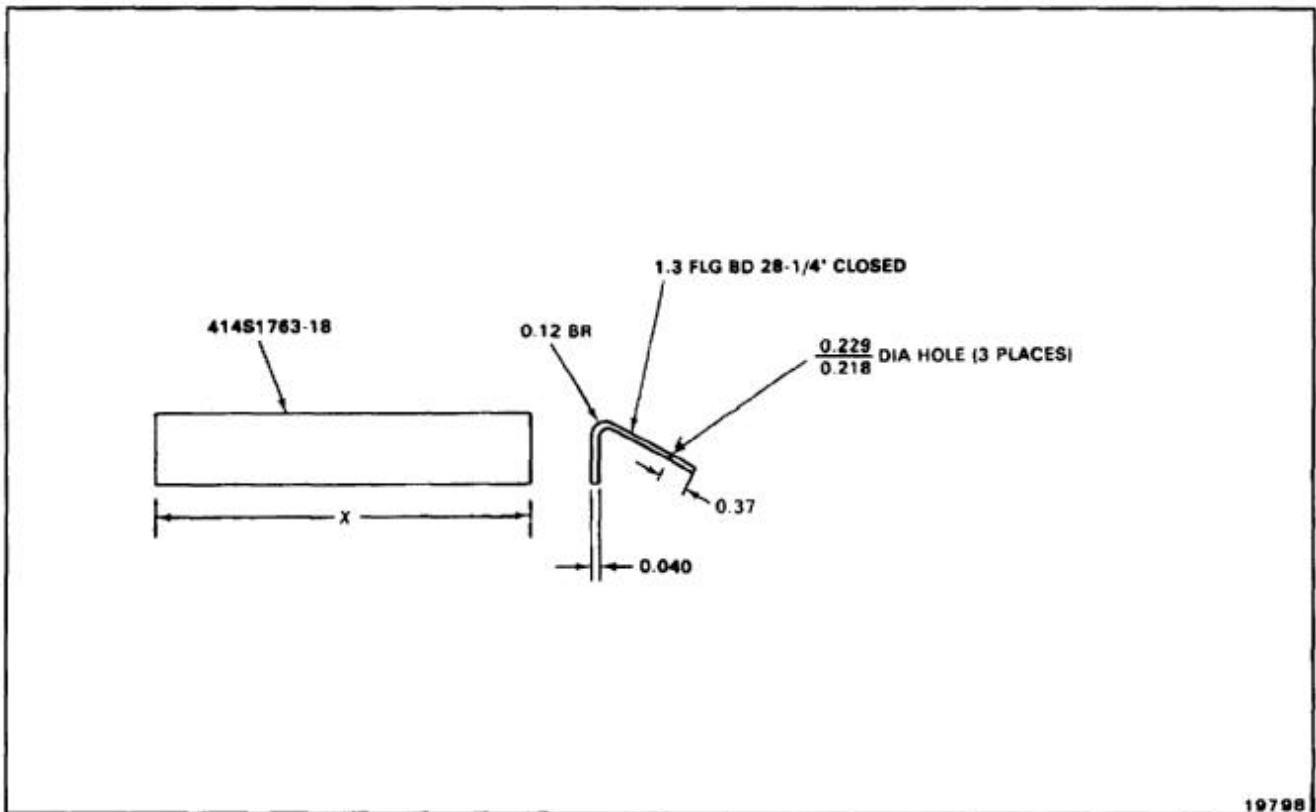

END OF TASK

E-274

NOTES:

1. FABRICATE FROM NONMETALLIC SPECIAL VS80540 SEAL.
2. STOCK SIZE 112.0 LG.
3. ALL DIMENSIONS IN INCHES.
4. TRIM TO FIT.

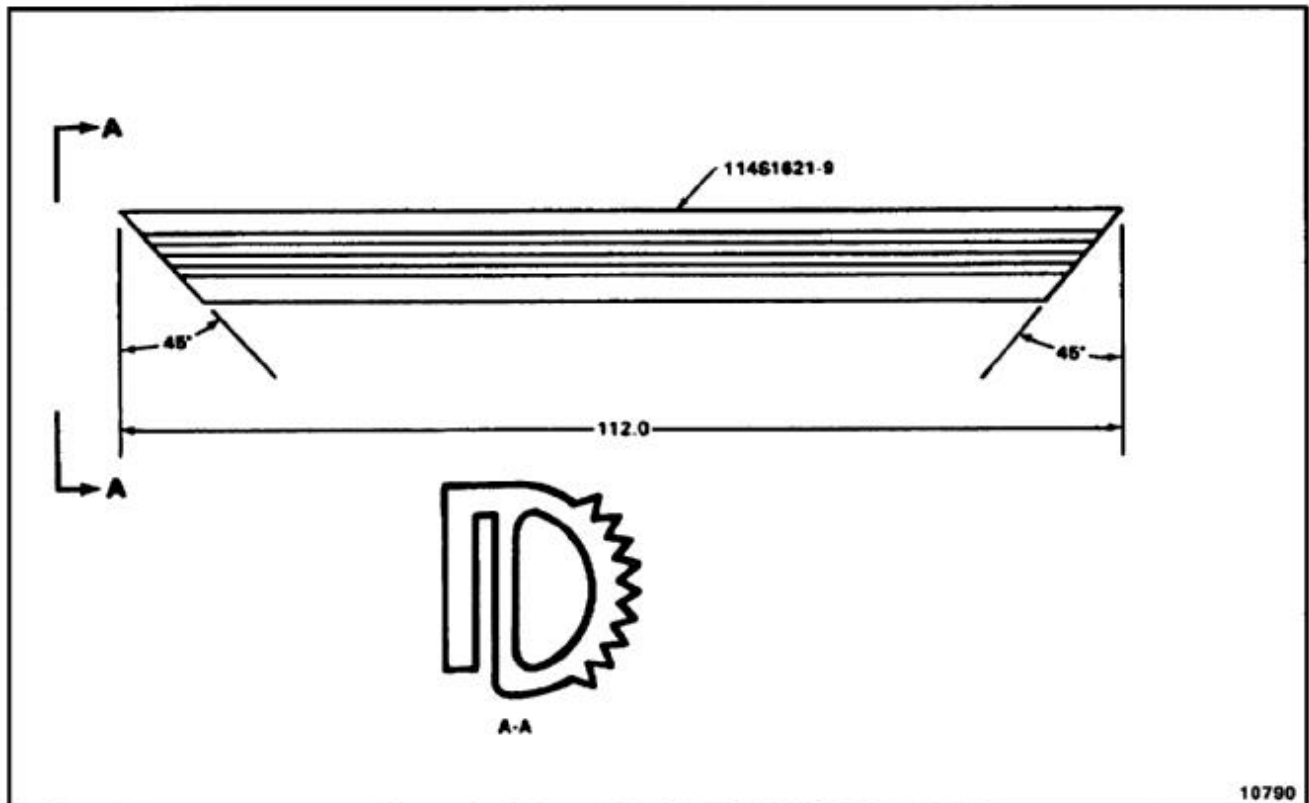

END OF TASK

NOTES:

1. FABRICATE FROM MS20253P5 CADMIUM PLATED CORROSION RESISTANT STEEL.
2. STOCK SIZE 17.0.
3. ALL DIMENSIONS IN INCHES.

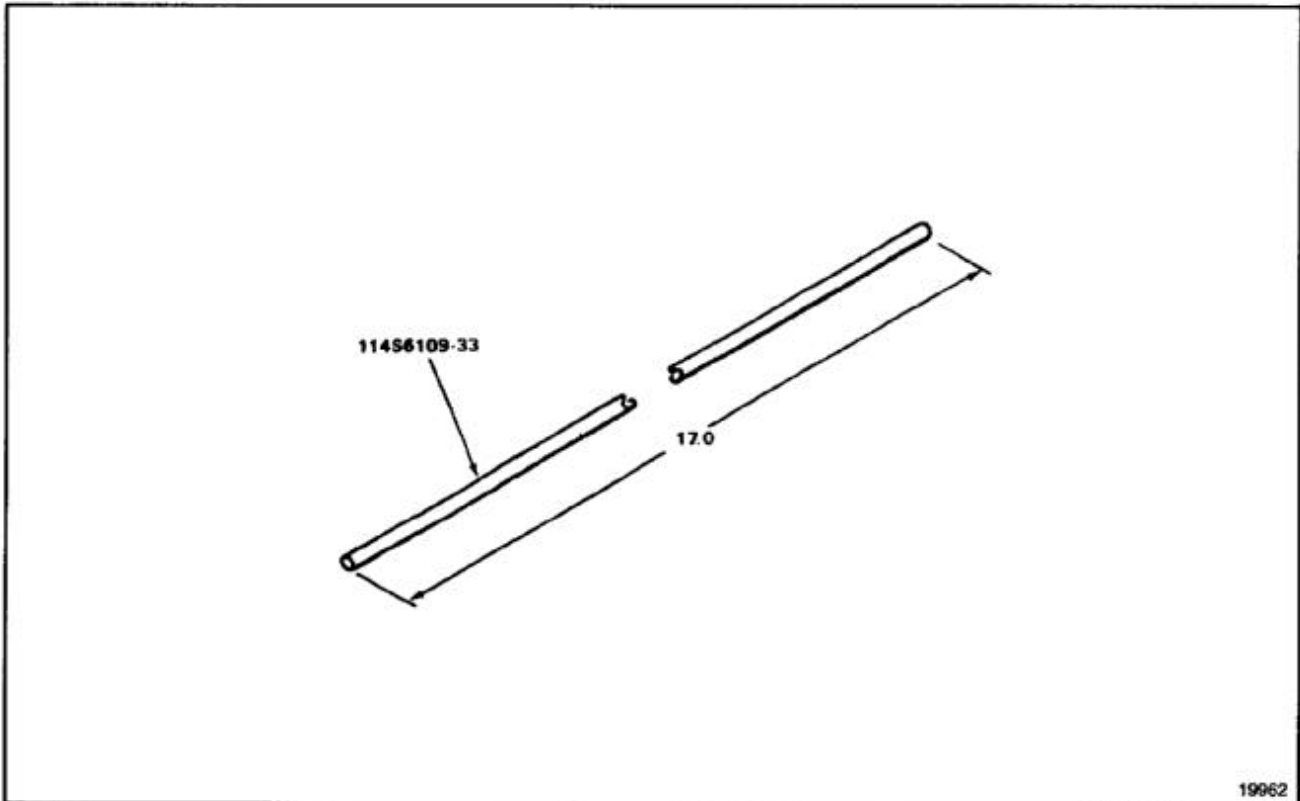

19962

END OF TASK

E-276

NOTES:

1. FABRICATE FROM ALUMINUM ALLOY CLAD SHEET 2024-T4 PER QQ-A-250/5.
2. STOCK SIZE 0.032 X 2.0 X 9.9.
3. ALL DIMENSIONS IN INCHES.
4. USE ORIGINAL ANGLE TO DETERMINE HOLE LOCATIONS AND DIMENSIONS X, Y, AND Z.
5. FINISH AS REQUIRED.

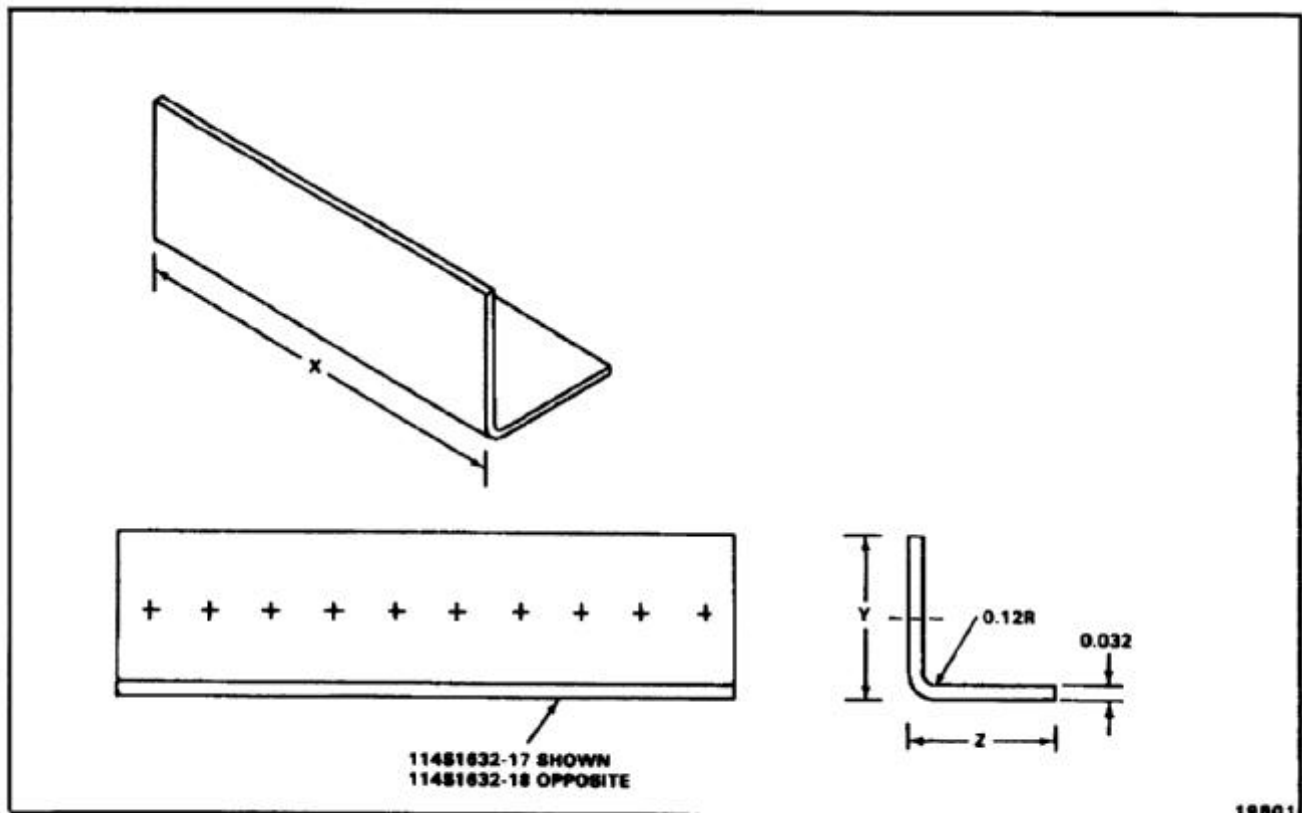

END OF TASK

NOTES:

1. FABRICATE FROM ALUMINUM ALLOY CLAD SHEET 2024-T4 PER QQ-A-250/5.
2. STOCK SIZE 0.032 X 2.0 X 5.4.
3. ALL DIMENSIONS IN INCHES.
4. USE ORIGINAL ANGLE TO DETERMINE DIMENSIONS X, Y, AND Z.
5. FINISH AS REQUIRED.

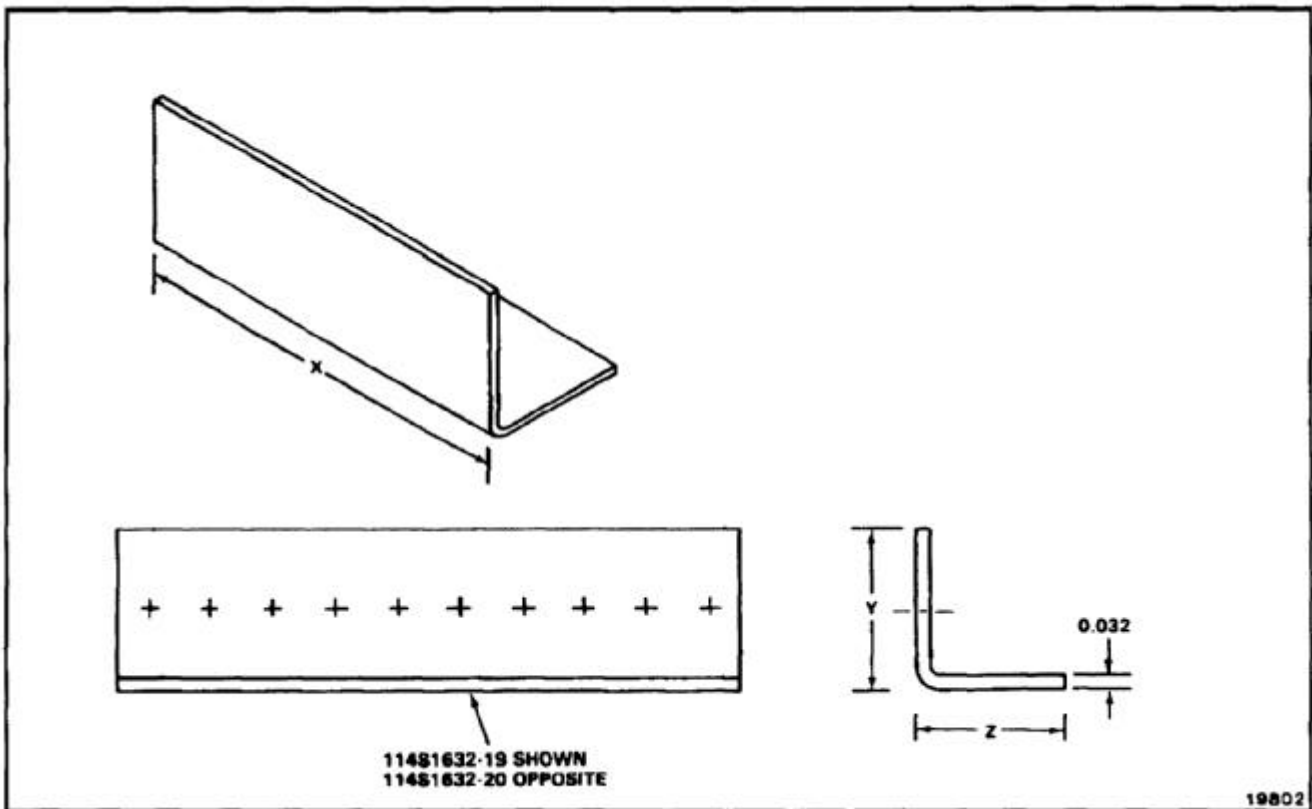

END OF TASK

NOTES:

1. FABRICATE FROM MS2001-PH4. STOCK SIZE 17.5 INCHES.
2. USE ORIGINAL HINGE HALF TO LOCATE PILOT HOLES AND DETERMINE DIMENSION X VALUE.
3. FINISH AS REQUIRED.

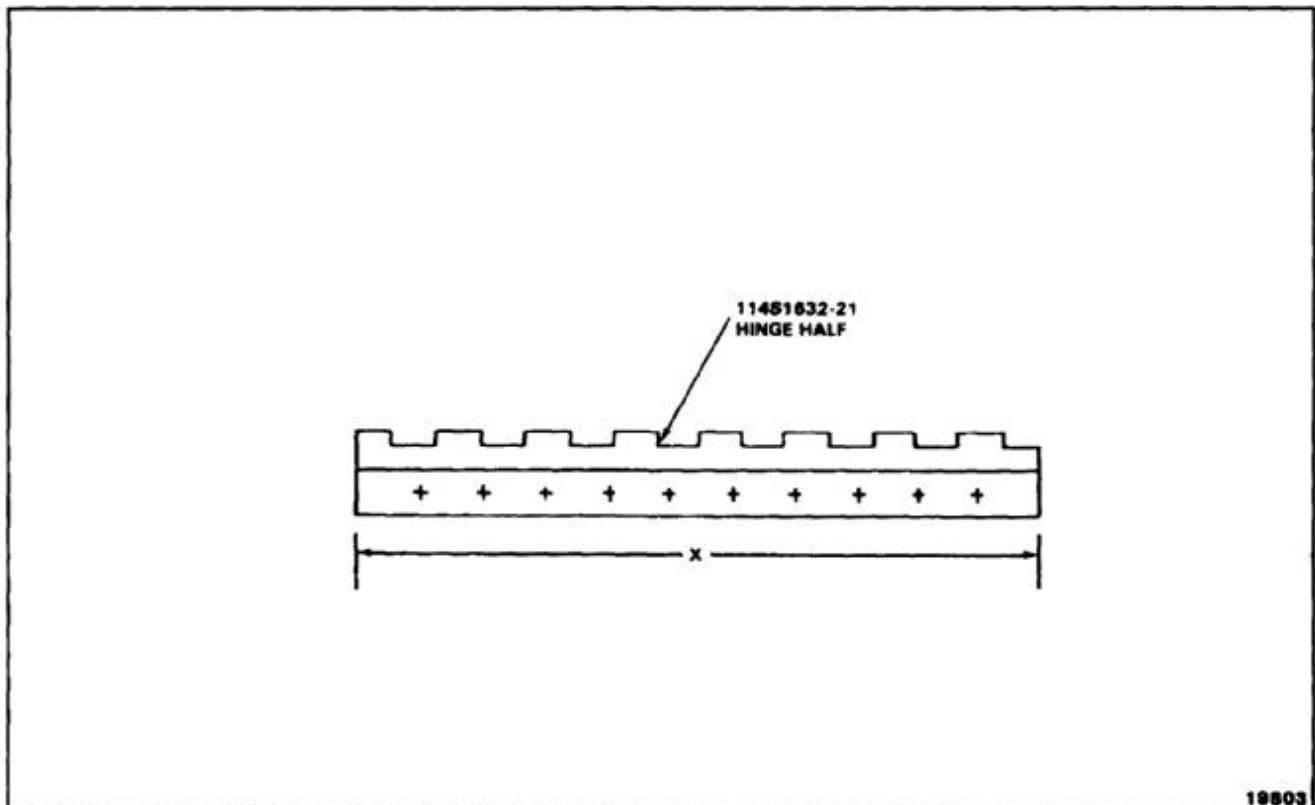

END OF TASK

NOTES:

1. FABRICATE FROM ALUMINUM ALLOY CLAD SHEET 2024-T4 PER QQ-A-250/11.
2. STOCK SIZE 0.040 X 2.3 X 3.1.
3. ALL DIMENSIONS IN INCHES.
4. USE ORIGINAL BRACKET TO DETERMINE X, Y, AND Z DIMENSIONS AND SLOT LOCATIONS.
5. FINISH AS REQUIRED.

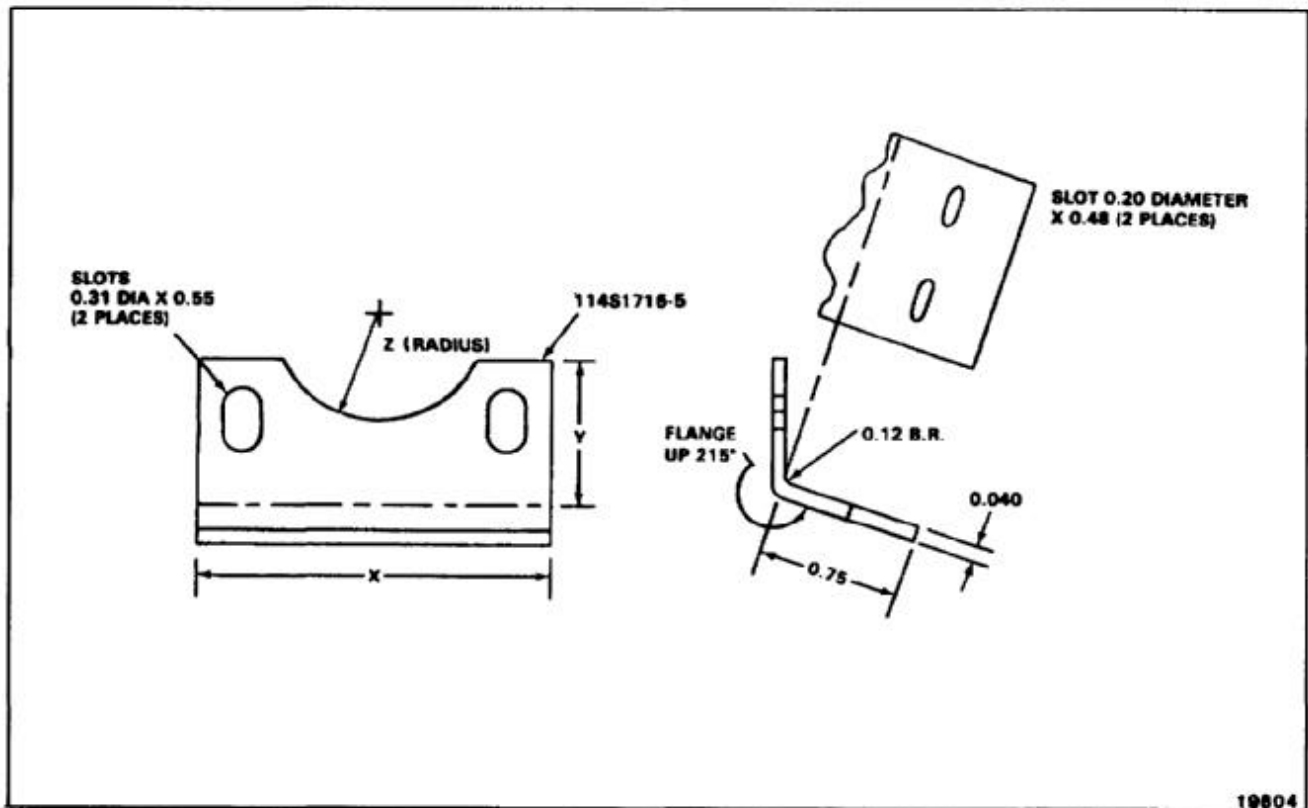

END OF TASK

E-280

NOTES:

1. FABRICATE FROM CRES SHEET 301, 1/2 HARD, PER MIL-S-5059.
2. STOCK SIZE 0.040 X 1.6 X 3.2.
3. ALL DIMENSIONS IN INCHES.
4. USE ORIGINAL PLATE TO DETERMINE X, Y, Z, AND CUTOUT DIMENSIONS.
5. FINISH AS REQUIRED.

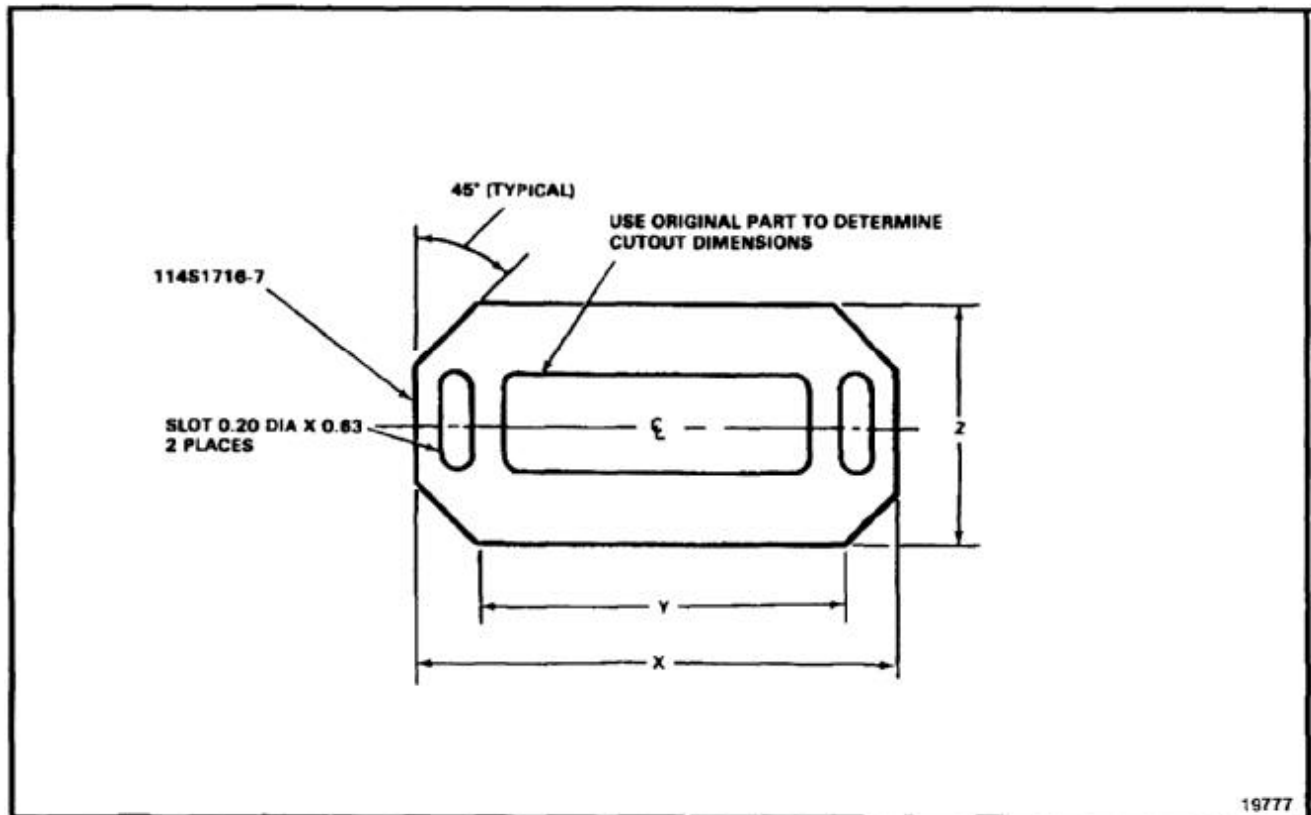

END OF TASK

NOTES:

1. FABRICATE FROM MS20253P2-250.
2. STOCK SIZE 2.50 INCHES.
3. ALL DIMENSIONS IN INCHES.

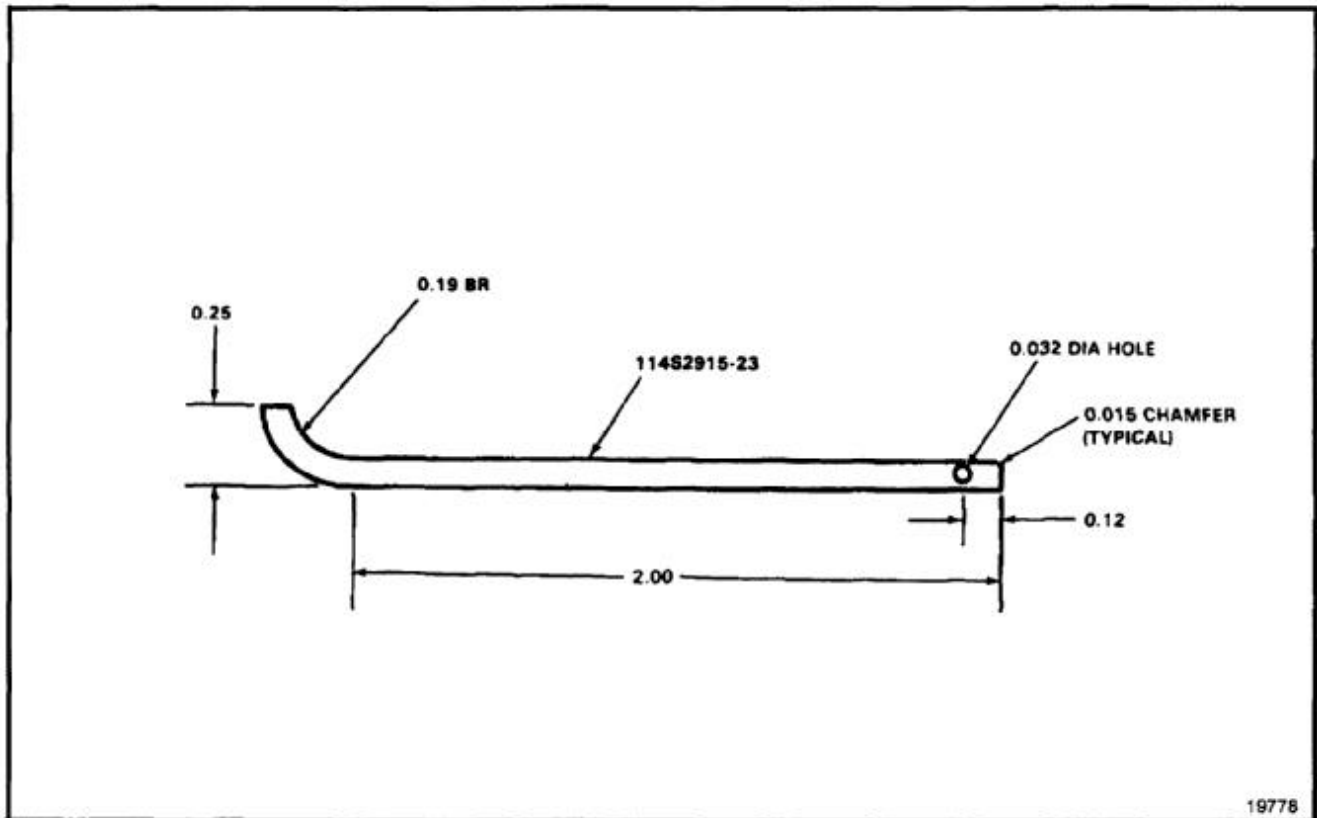

END OF TASK

E-282

NOTES:

1. FABRICATE FROM AND10134-1601
ALUMINUM ALLOY EXTRUSION 7075-T6511
PER QQ-A-200/11.
2. STOCK SIZE 11.0 INCHES.
3. ALL DIMENSIONS IN INCHES.
4. USE ORIGINAL CLIP TO LAYOUT SHAPE,
PILOT HOLES, AND DIMENSIONS X, Y, AND Z.
5. FINISH AS REQUIRED.

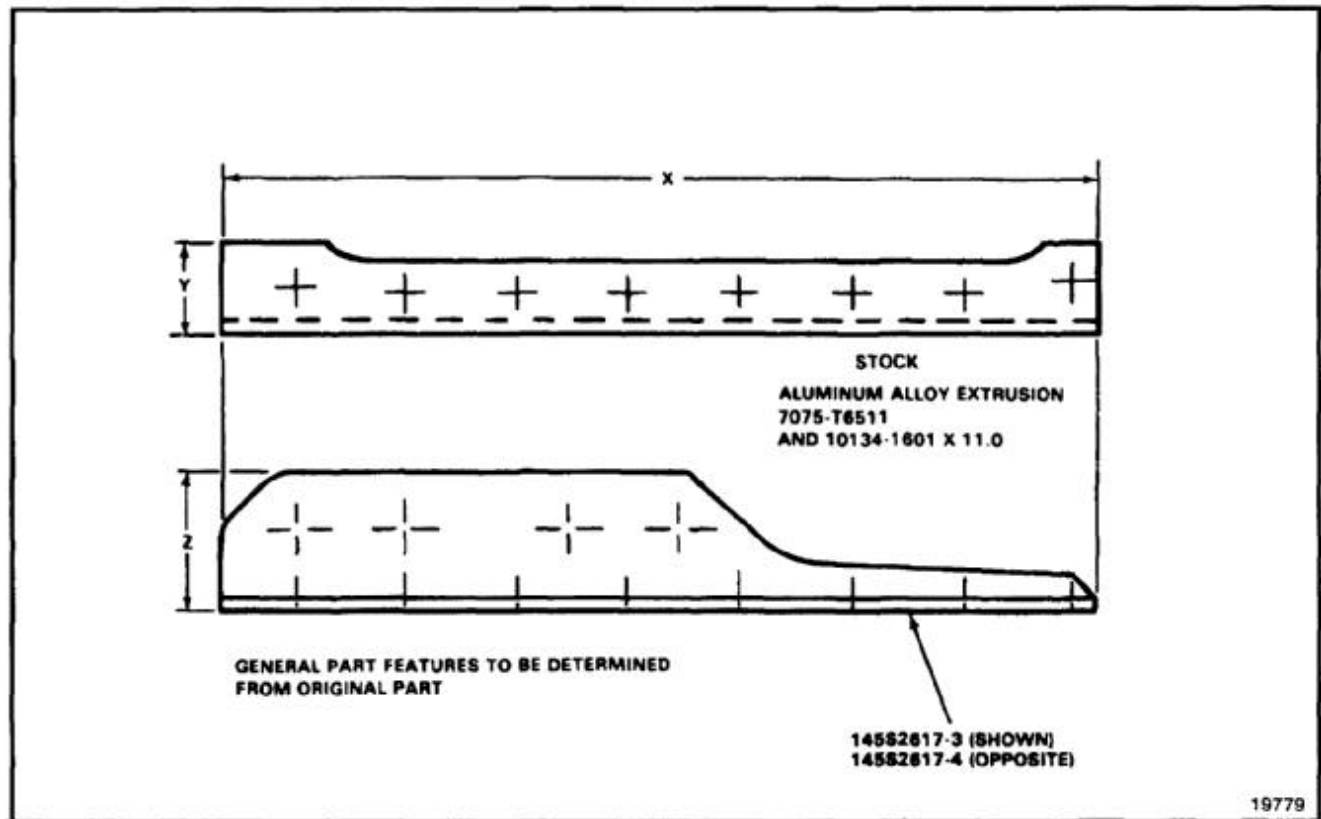

END OF TASK

NOTES:

1. FABRICATE FROM AND10133-2401 ALUMINUM ALLOY EXTRUSION 7075-T6511.
2. STOCK SIZE 5.0.
3. ALL DIMENSIONS IN INCHES.
4. USE ORIGINAL PART TO LOCATE PILOT HOLES AND DETERMINE X, Y, AND Z VALUES.
5. FINISH AS REQUIRED.

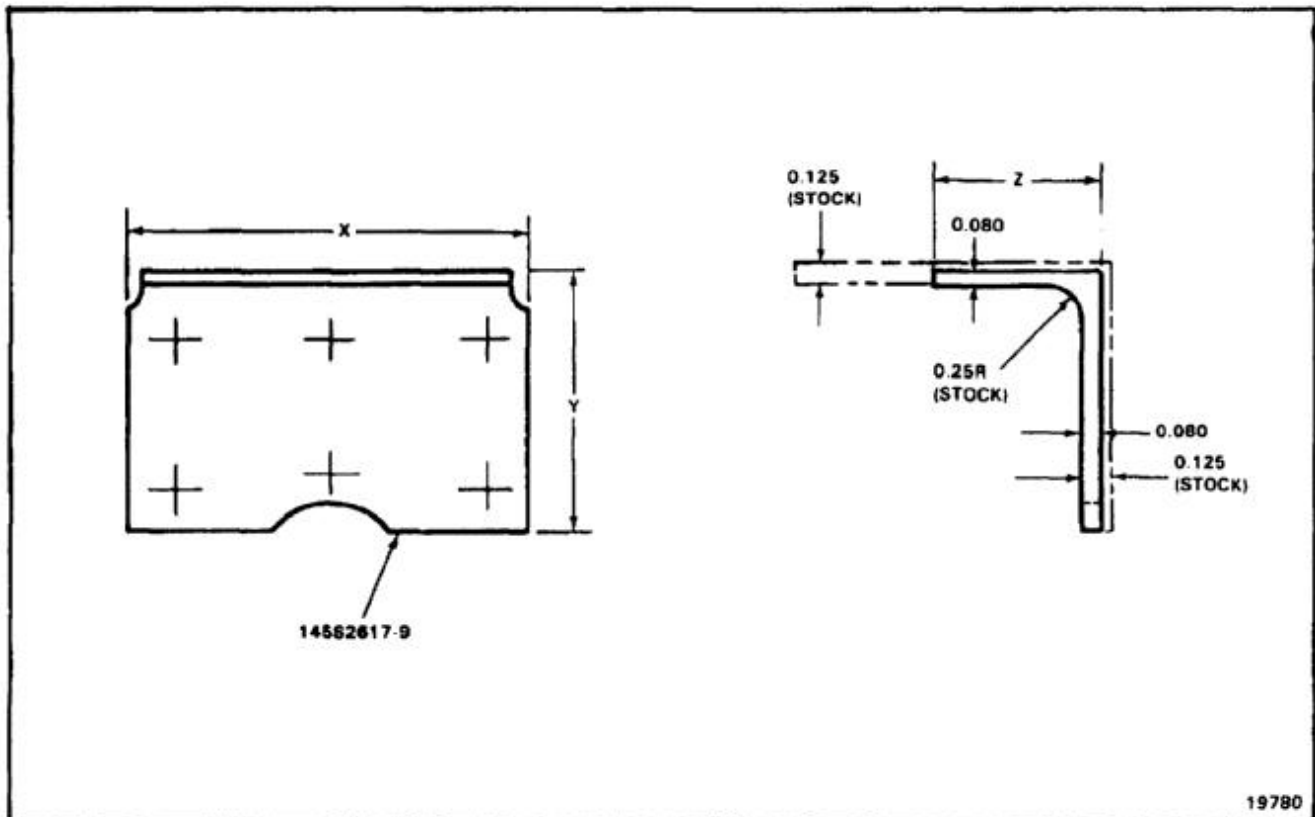

END OF TASK

E-284

NOTES:

1. FABRICATE FROM ALUMINUM ALLOY CLAD SH 2024-T3 PER QQ-A-250/5.
2. STOCK SIZE 0.050 X 1.2 X 43.4.
3. ALL DIMENSIONS IN INCHES.
4. USE ORIGINAL PART TO DETERMINE DIMENSIONS X AND Y AND PILOT HOLE LOCATIONS.
5. FINISH AS REQUIRED.

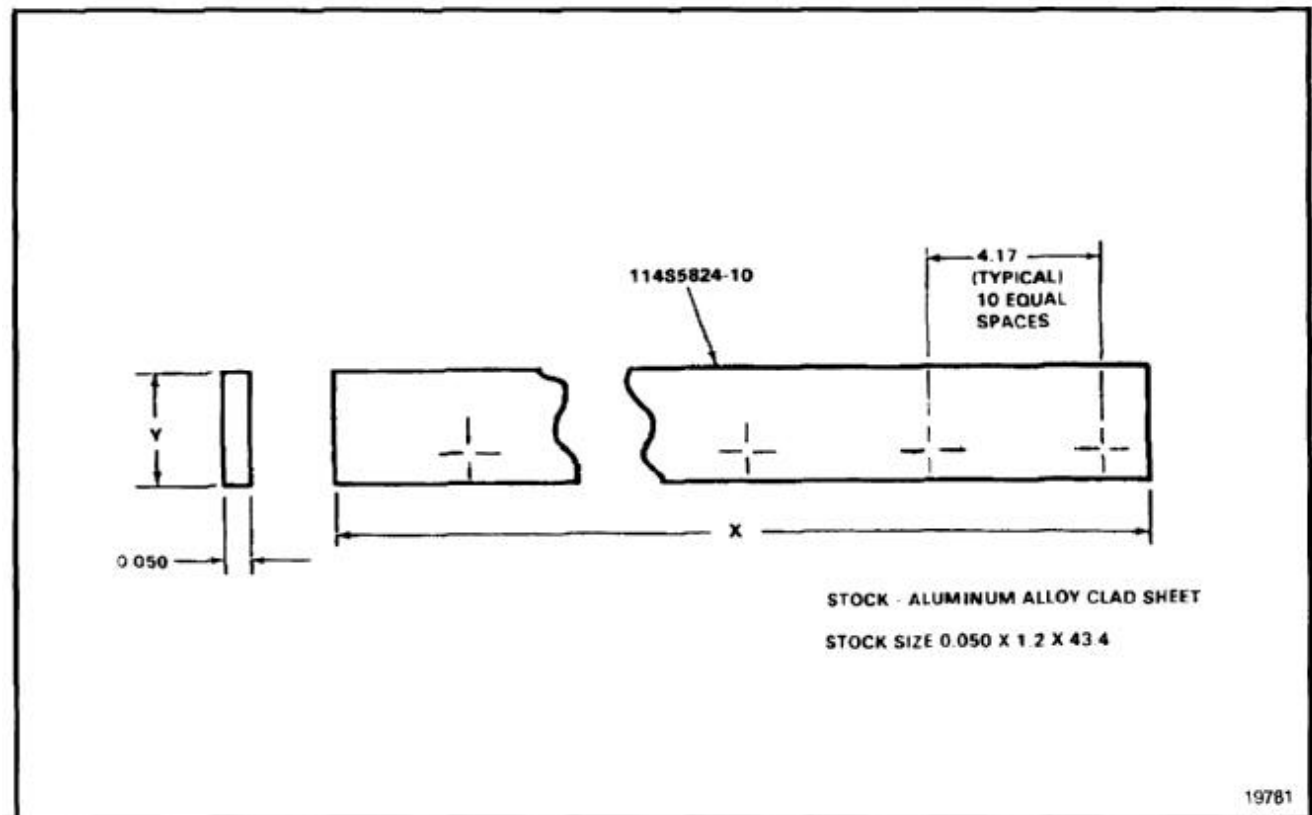

END OF TASK

NOTES:

1. FABRICATE FROM ALUMINUM ALLOY CLAD PLATE 2024-T351 PER QQ-A-250/5.
2. STOCK SIZE 0.30 X 1.3 X 3.9.
3. ALL DIMENSIONS IN INCHES.
4. USE ORIGINAL PART TO DETERMINE DIMENSIONS X AND Y.
5. FINISH AS REQUIRED.

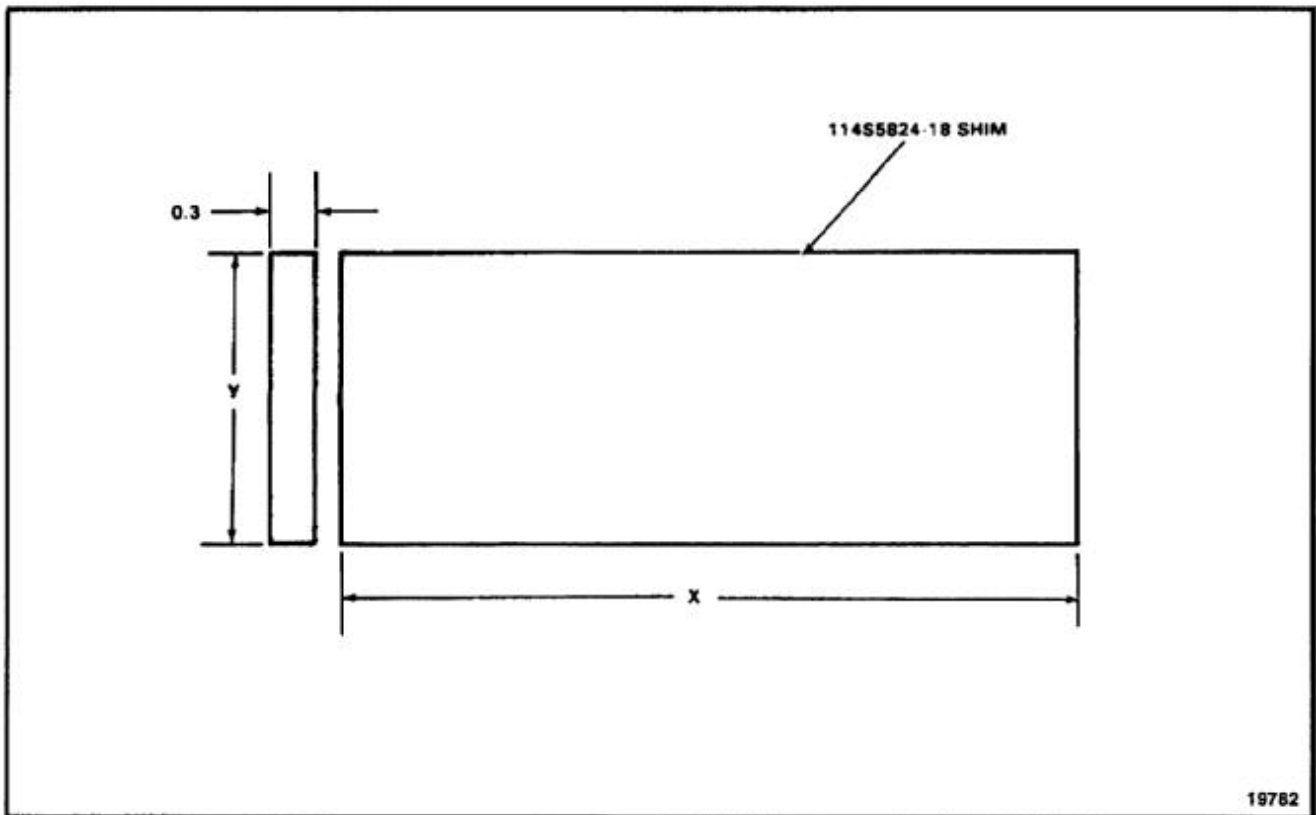

19782

END OF TASK

E-286

E-211 CABIN CROWN ACCESS TUNNEL COVER INSTALLATION SEALS 114S2915-39, -40, -41, AND -42

E-211

NOTES:

1. FABRICATE FROM VS80572-1 SEAL.
2. STOCK SIZE SEE NOTE 3.
- 3.

PART NUMBER STOCK SIZE (X DIMENSION) IN INCHES

114S2915-39	56.2
114S2915-40	39.0
114S2915-41	60.5
114S2915-42	22.0

4. USE ORIGINAL PART TO DETERMINE DIMENSION X.

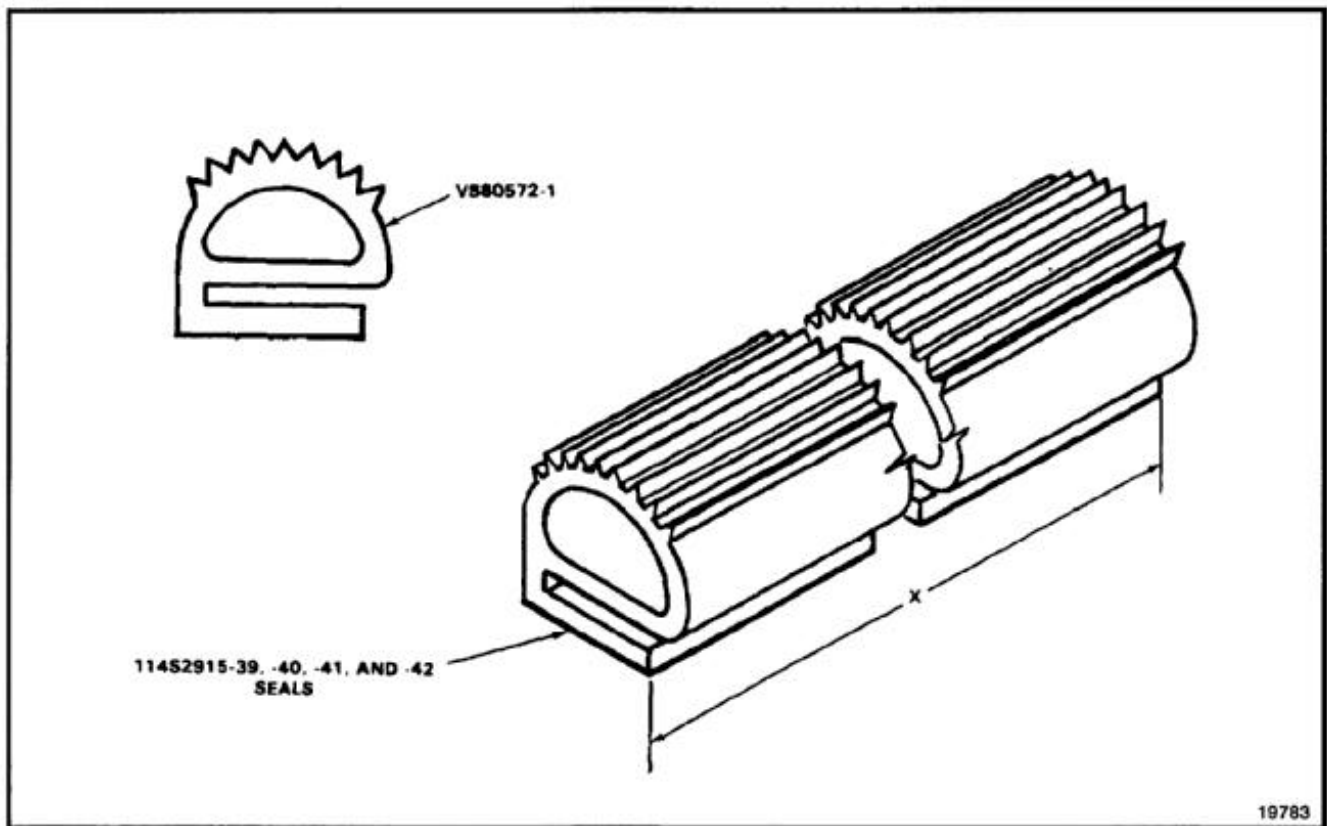

19783

END OF TASK

NOTES:

1. FABRICATE FROM SILICONE RUBBER BAC1521-699.
2. USE ORIGINAL PART TO DETERMINE DIMENSION X.

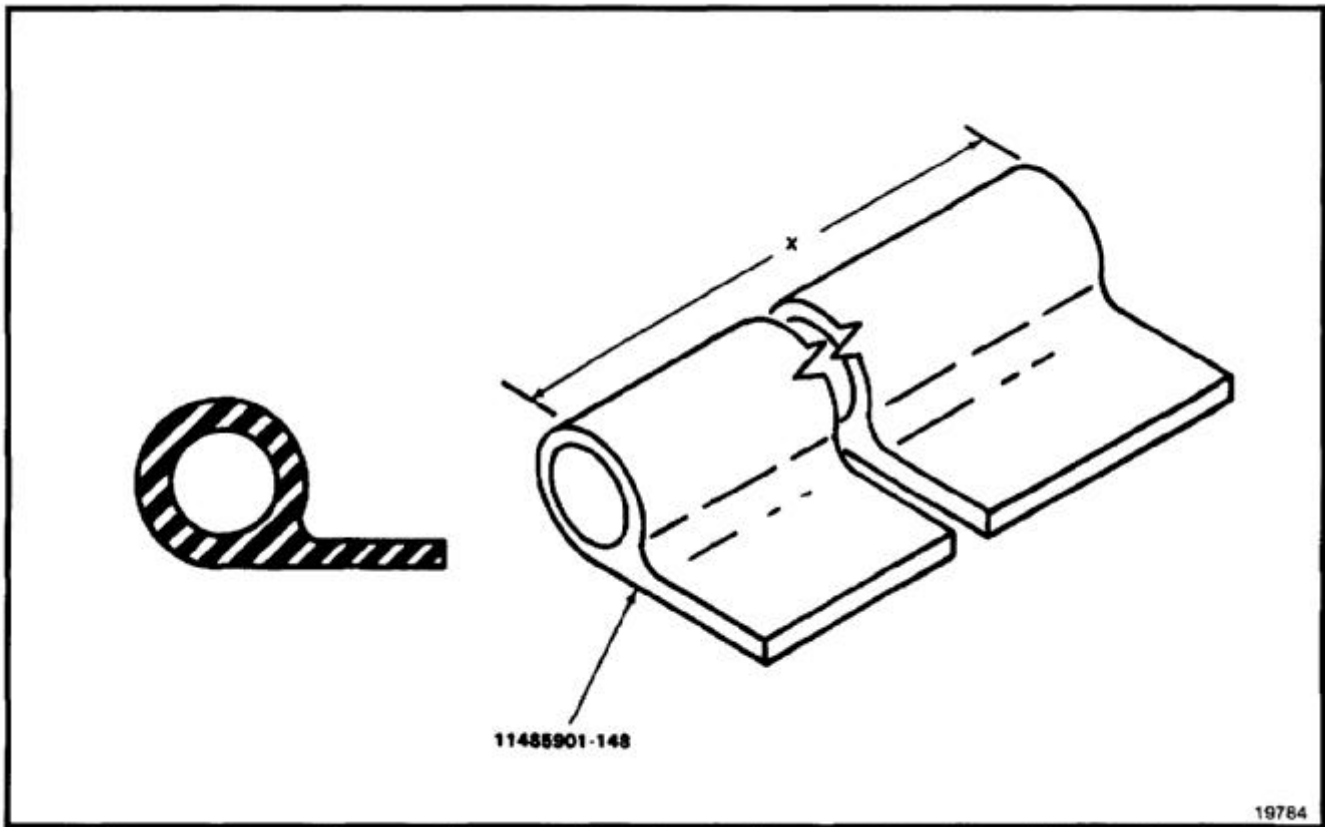

END OF TASK

E-288

NOTES:

1. FABRICATE HINGE HALVES FROM HINGE MATERIAL LISTED IN NOTE 5.
2. ALL DIMENSIONS IN INCHES.
3. CUT AND DRILL HINGE HALVES TO MATCH ORIGINAL HINGE HALVES.
4. MAKE HINGE PIN 114S5901-67 FROM MATERIAL LISTED IN NOTE 5.
- 5.

PART NUMBER	MATERIAL	LENGTH
114S5901-128	MS20001PX6	16.2
114S5901-129	MS20001PY6	22.2
114S5901-130	MS20001PY6	16.2
114S5901-131	MS20001PY6	16.2
114S5901-132	MS20001PX6	22.2
114S5901-133	MS20001PX6	22.2
114S5901-67	MS20253P2	22.0
MS20253P2-1600	MS20253P2	16.0

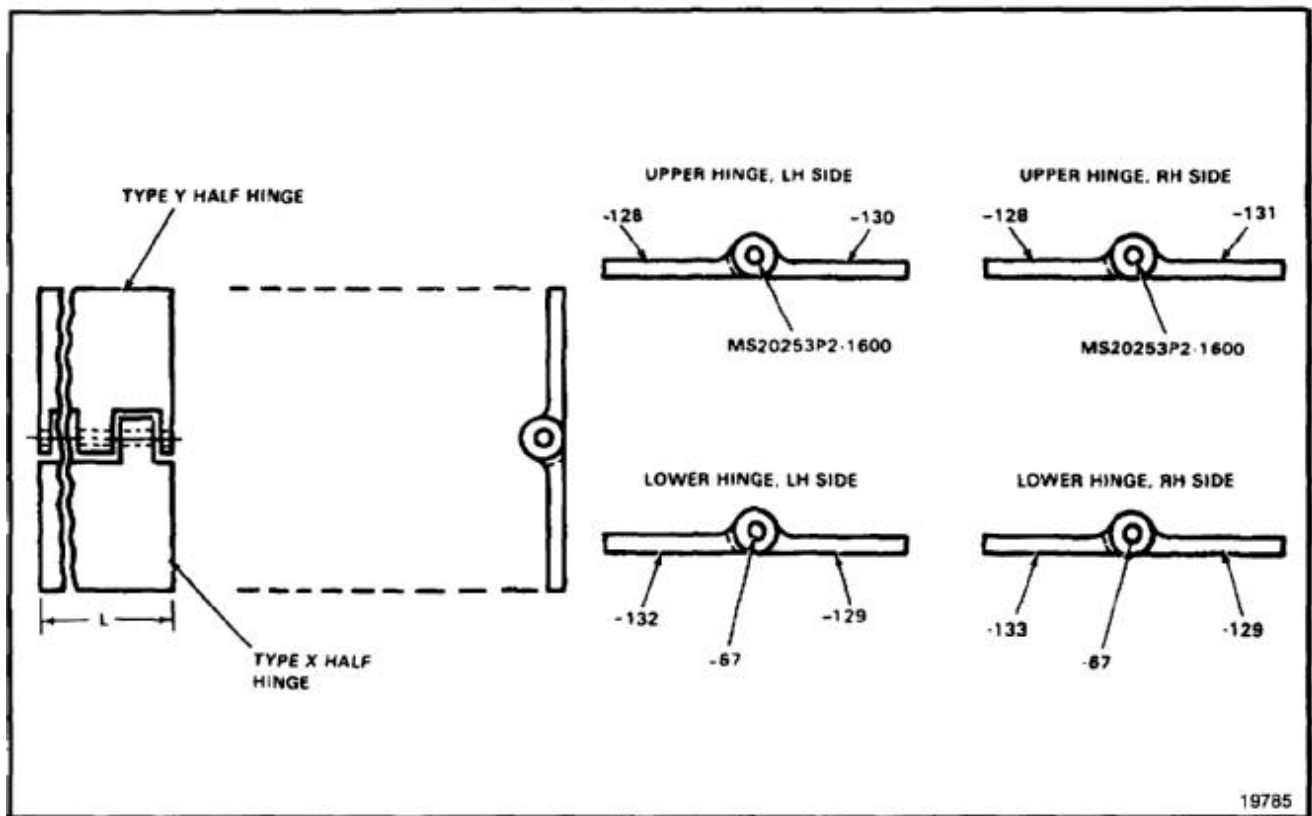

END OF TASK

NOTES:

1. FABRICATE FROM ALUMINUM ALLOY CLAD SHEET 2024-T3 PER QQ-A-250/5.
2. STOCK SIZE 0.032 X 3.8 X 30.5 INCHES.
3. USE ORIGINAL RETAINER TO LAYOUT SHAPE AND TO DETERMINE DIMENSIONS AND HOLE LOCATIONS.

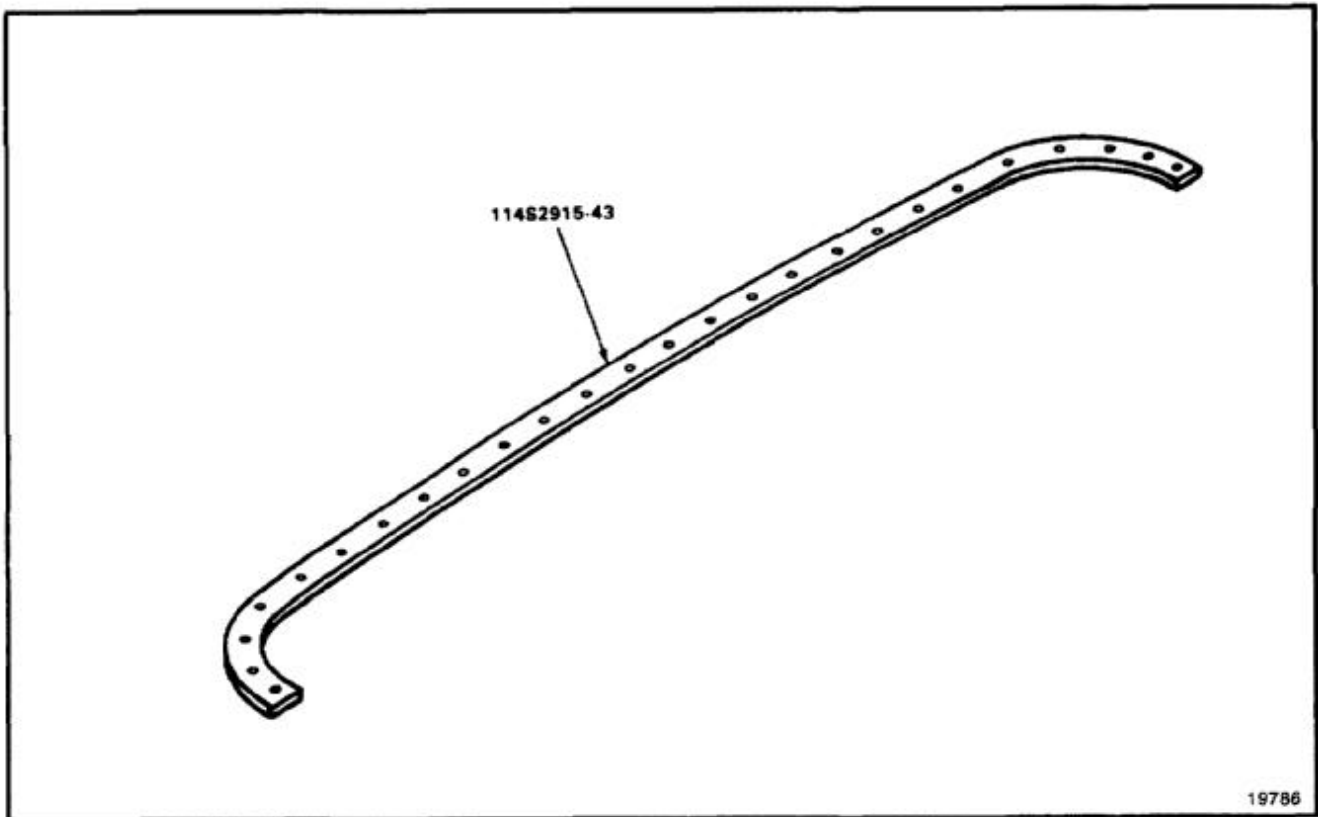

END OF TASK

E-290

**E-215 CABIN CROWN ACCESS TUNNEL COVER INSTALLATION SEAL RETAINERS
114S2915-44, -45, -46, AND -47**

E-215

NOTES:

1. FABRICATE FROM ALUMINUM ALLOY CLAD SHEET 2024-T3 PER QQ-A-250/5.
2. STOCK SIZE 0.020 X 0.62 (SEE NOTE 4 FOR LENGTH).
3. ALL DIMENSIONS IN INCHES.
- 4.

PART NUMBER	STOCK SIZE (X DIMENSION)
114S2915-44	55.9
114S2915-45	38.8
114S2915-46	60.2
114S2915-47	21.7

5. USE ORIGINAL PART TO DETERMINE DIMENSIONS X AND Y.

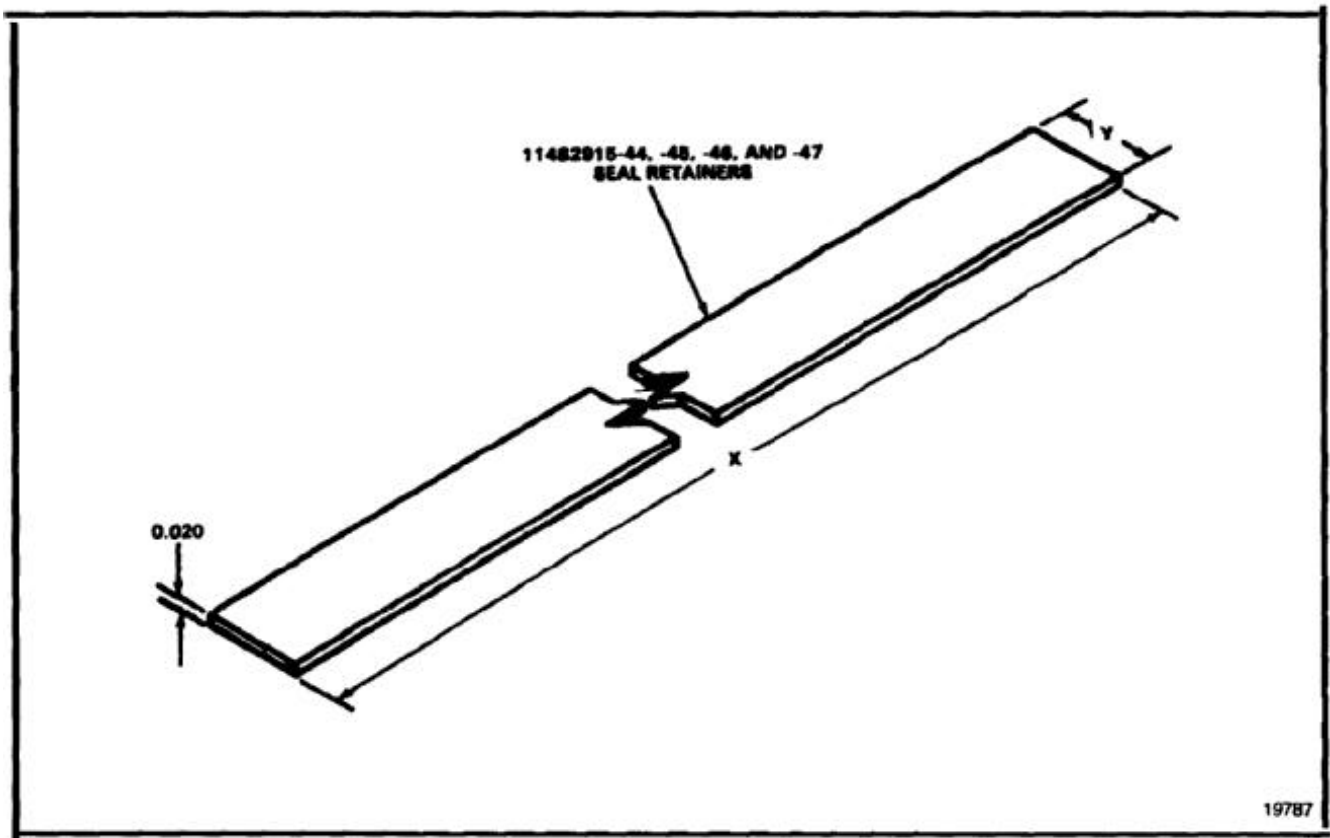

19787

END OF TASK

NOTES:

1. FABRICATE HINGE HALVES FROM MS20001PH5-4540.
2. FABRICATE PIN FROM MS20253-2-4340.
3. USE ORIGINAL PARTS TO DETERMINE PILOT HOLE LOCATIONS, HINGE HALF, AND HINGE PIN LENGTH.
4. FINISH AS REQUIRED.
- 5.

NOMENCLATURE	PART NUMBER	MATERIAL
HINGE HALF	114S5824-12	MS20001PH5-4540
HINGE HALF	114S5824-13	MS20001PH5-4540
HINGE PIN	114S5824-29	MS20253-2-4340

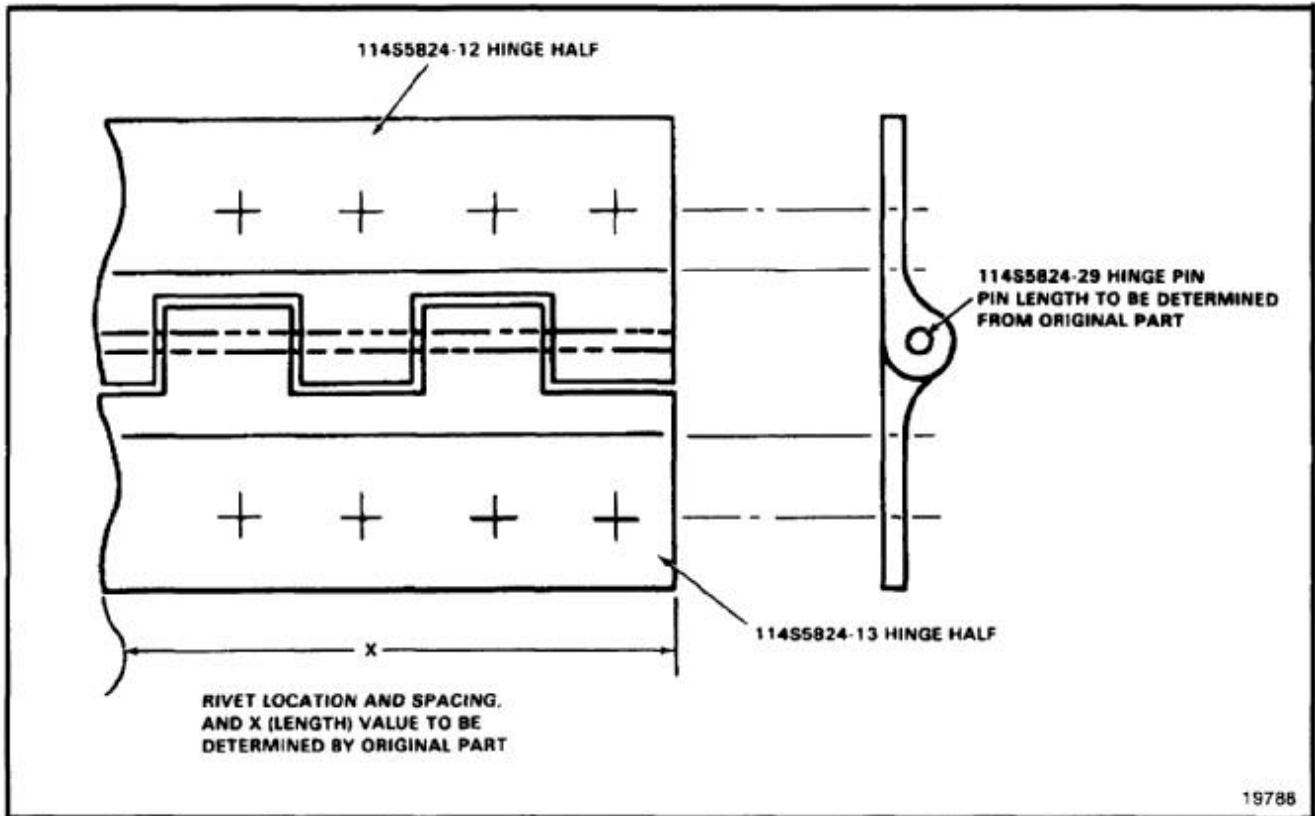

END OF TASK

**E-217 ISOLATION INSTALLATION, AUXILIARY FUEL POD BOTTOM HINGE COMPONENTS
114S5824-14 -15 AND -30**

E-217

NOTES:

1. FABRICATE HINGE HALVES AS SHOWN BELOW.
2. FABRICATE PIN FROM MS20253-2-4780.
3. USE ORIGINAL PARTS TO DETERMINE PILOT HOLE LOCATIONS, HINGE HALF, AND HINGE PIN LENGTH.
4. FINISH AS REQUIRED.
- 5.

NOMENCLATURE	PART NUMBER	MATERIAL
HINGE HALF	114S5824-14	MS20001PH5-4850
HINGE HALF	114S5824-15	MS20001PH9-4850
HINGE PIN	114S5824-30	MS20253-2-4780

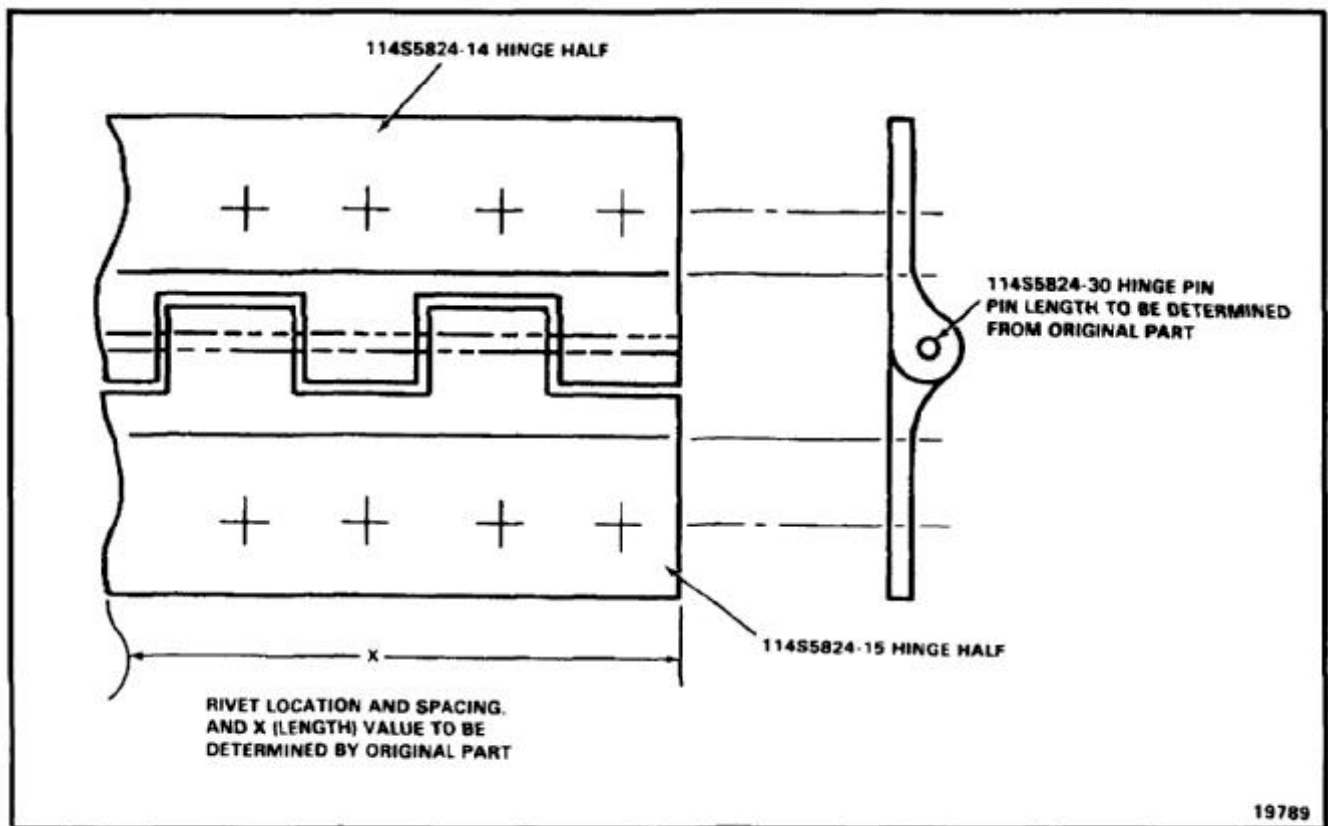

END OF TASK

NOTES:

1. FABRICATE FROM ALCOA 83264 AL ALY EXTRUSION 7075-T6 PER QQ-A-200/11.
2. STOCK SIZE 1.6 INCHES.
3. USE ORIGINAL RETAINER TO LOCATE PILOT HOLE AND DETERMINE X AND Y DIMENSIONS.
4. FINISH AS REQUIRED.

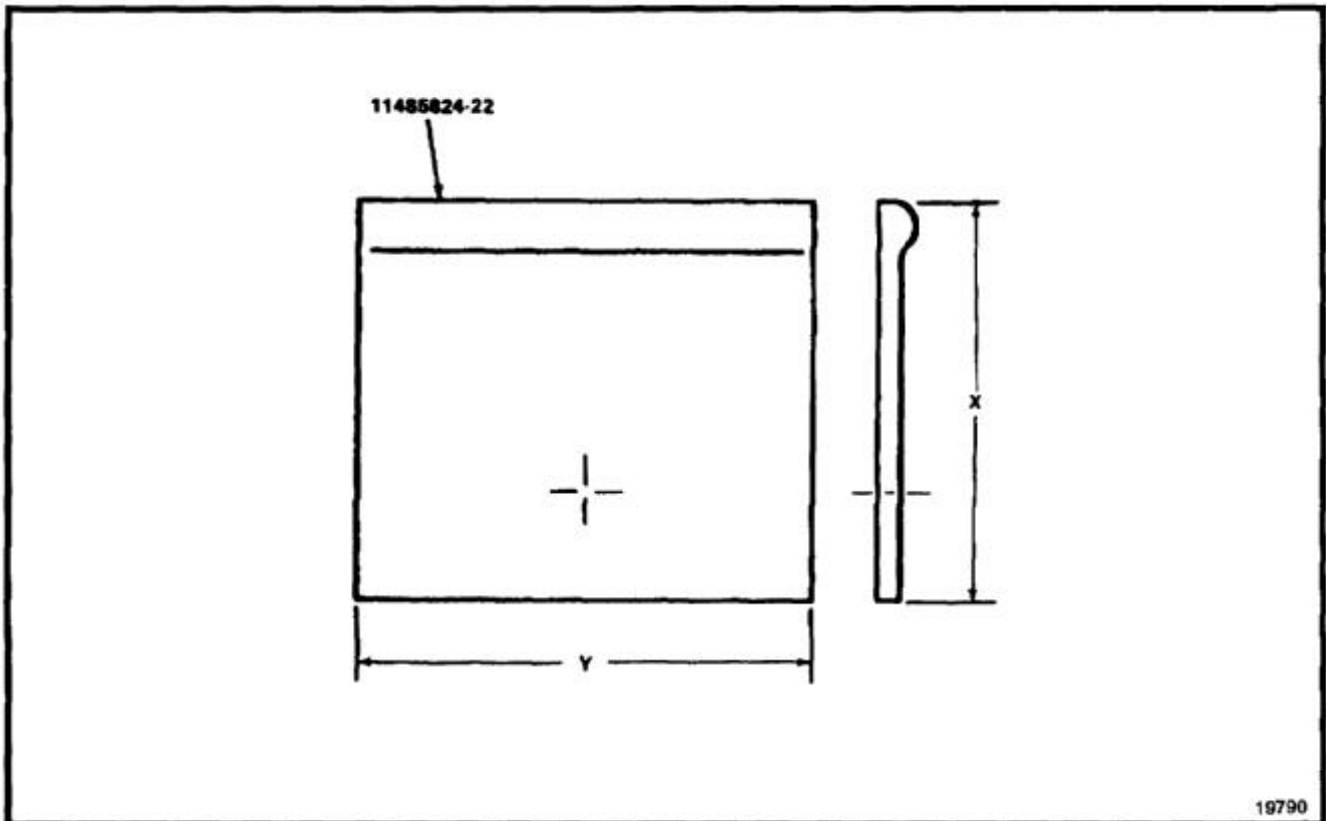

END OF TASK

NOTES:

1. FABRICATE FROM MS20001PH12X0180.
2. ALL DIMENSIONS IN INCHES.

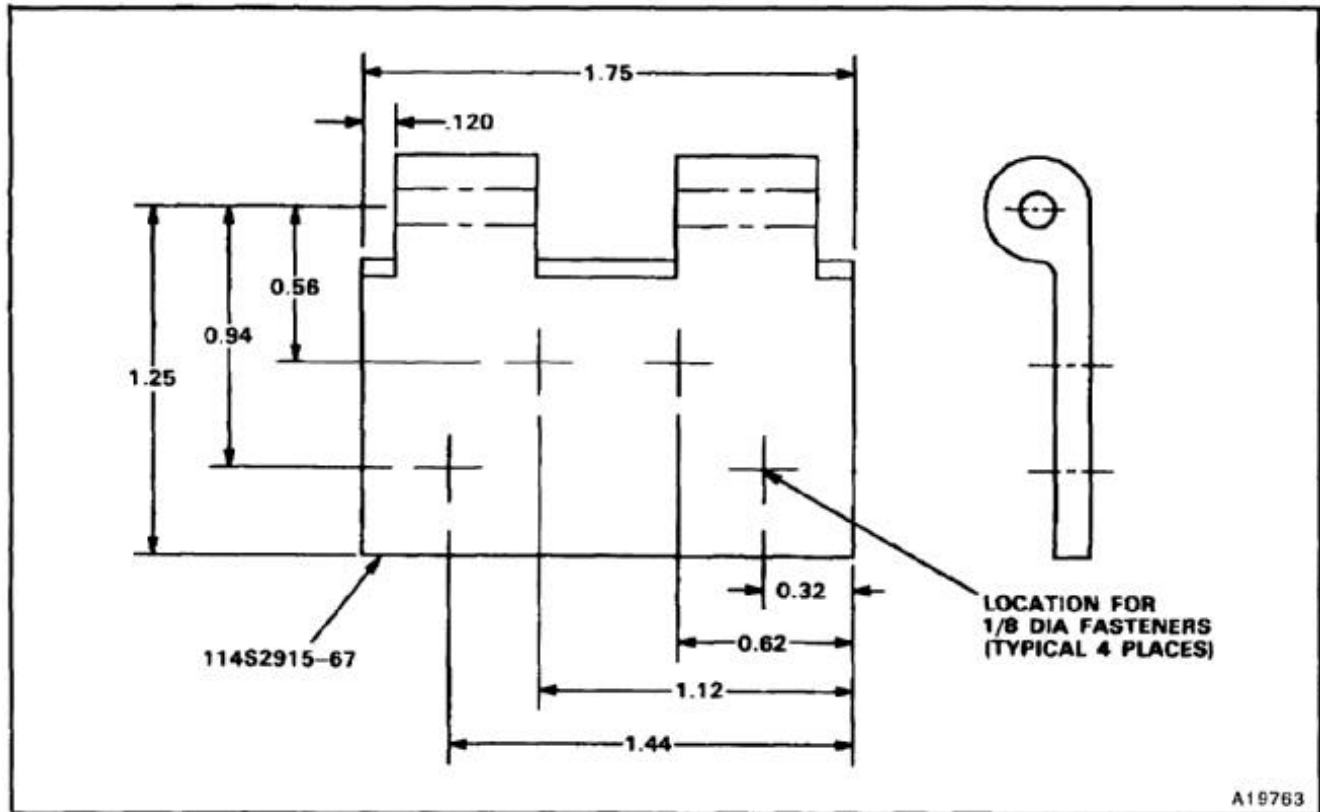

END OF TASK

NOTES:

1. FABRICATE FROM NYLON WEBBING-MIL-W-4088 TYPE XXI.
2. STOCK SIZE 0.065 X 1.25 X 4.75.
3. ALL DIMENSIONS IN INCHES.
4. USE ORIGINAL PART TO DETERMINE DIMENSIONS X AND Y.

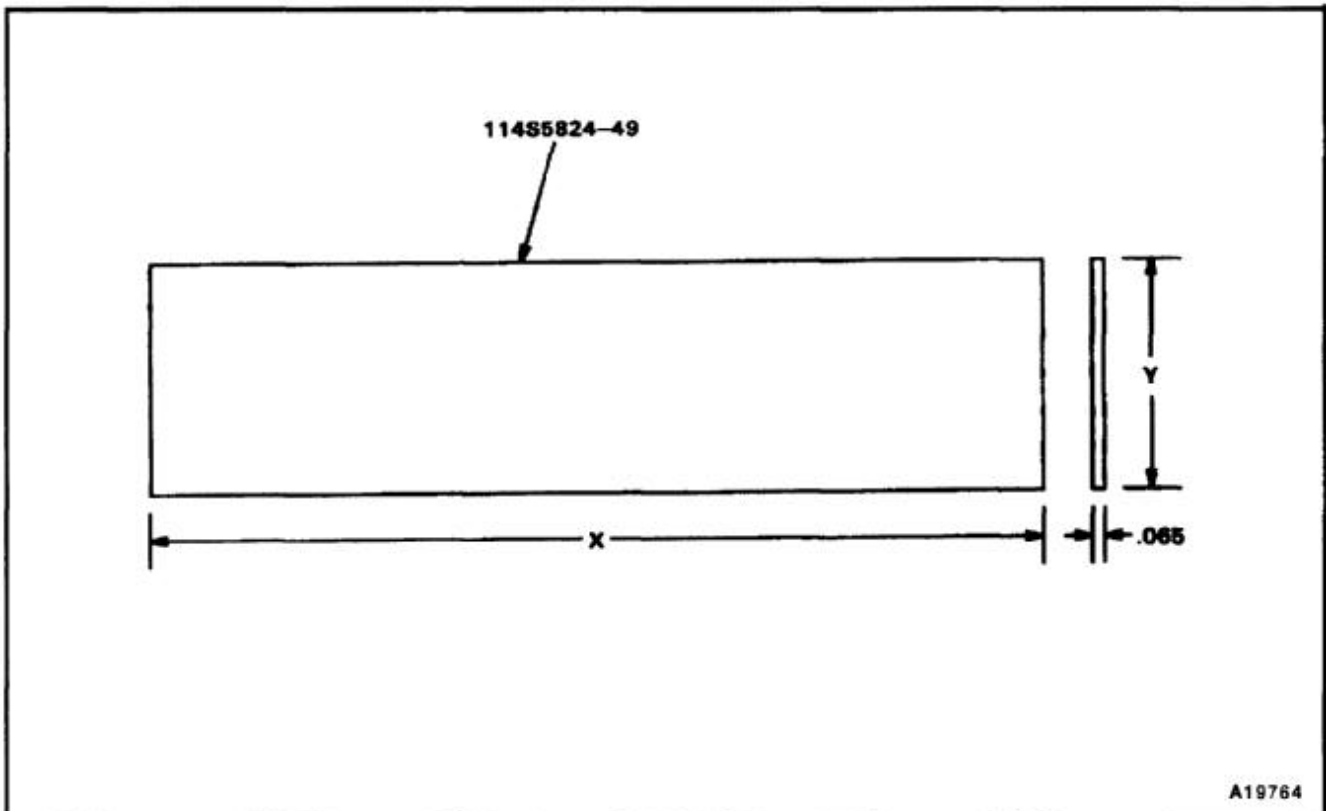

END OF TASK

NOTES:

1. FABRICATE FROM MS20257H4-730.
2. USE ORIGINAL HALF HINGE TO DETERMINE X DIMENSION AND TO LOCATE PILOT HOLES.

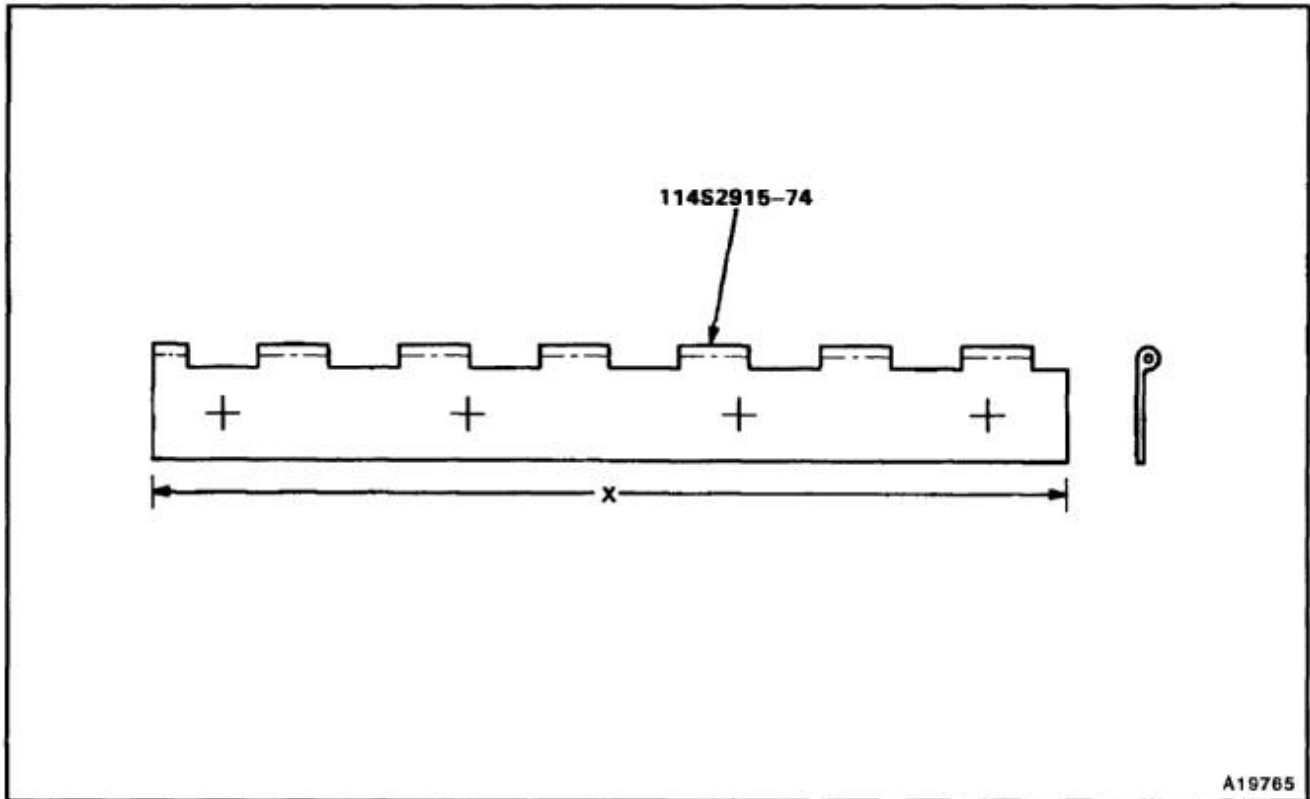

END OF TASK

NOTES:

1. FABRICATE 114S2915-58 STRAP FROM NYLON WEBBING - TCA CABLE 36231 MIL-W-4088, TYPE II, CINDER GRAY.
2. STOCK SIZE 1.00 X 8.50.
3. ASSEMBLE USING BACW10BD1 WASHER AND BACE10E1 EYELET.
4. ALL DIMENSIONS IN INCHES.

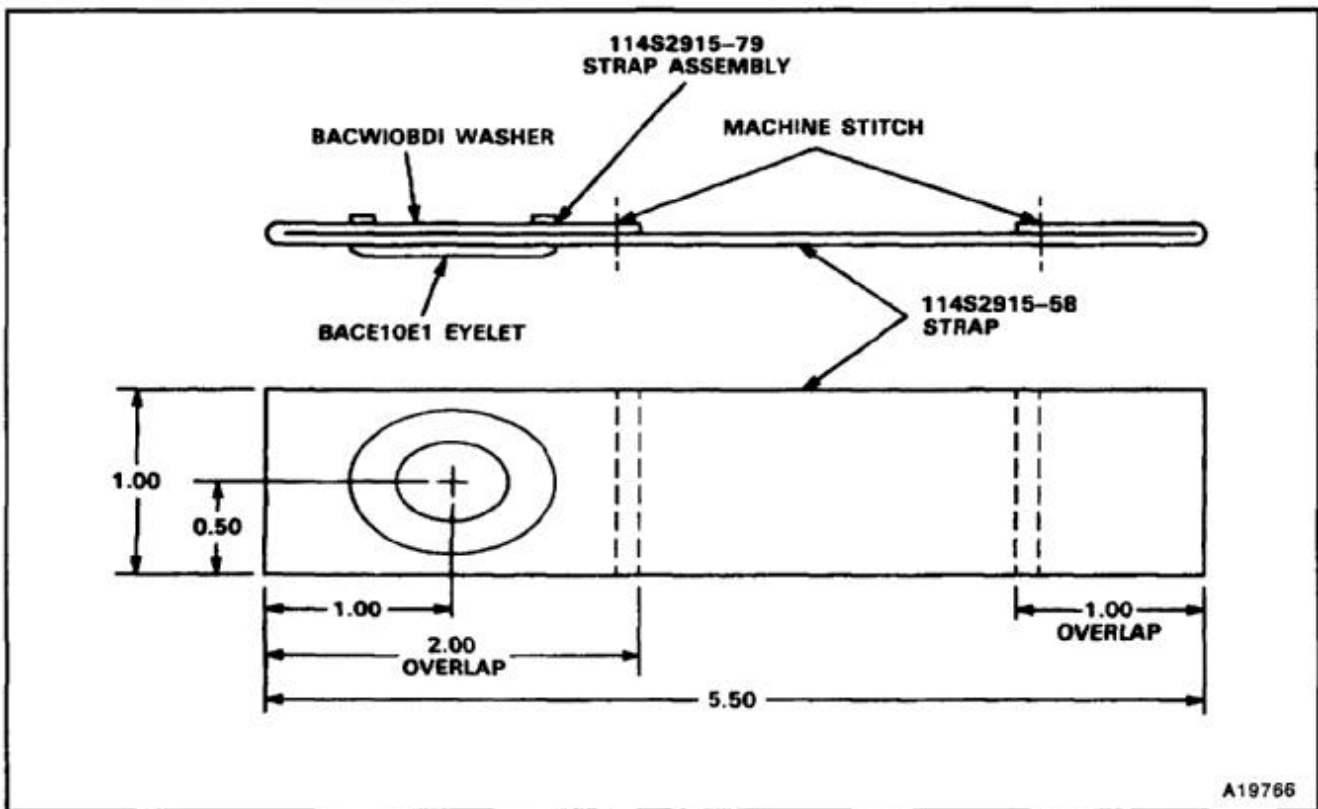

END OF TASK

NOTES:

1. FABRICATE FROM MS20253P3 X LENGTH (SEE NOTE 3).
2. ALL DIMENSIONS IN INCHES.
- 3.
4. 250 ✓ MAX MACHINED SURFACE FINISH PER MIL-STD-10.
5. FINISH: AFTER MACHINING DIP ENDS OF HINGE PINS IN ZINC CHROMATE PRIMER (E291) TO A DEPTH OF 0.50 INCH.
6. APPLY DRY FILM SPRAY LUBE MIL-L-23398 TO HINGE PINS PER MANUFACTURER'S INSTRUCTIONS.

PART NUMBER LENGTH (X DIMENSION)

114S5701-1	28.00
114S5701-3	22.40
114S5701-5	20.75
114S5701-7	9.40
114S5701-9	30.00
114S5701-11	19.60

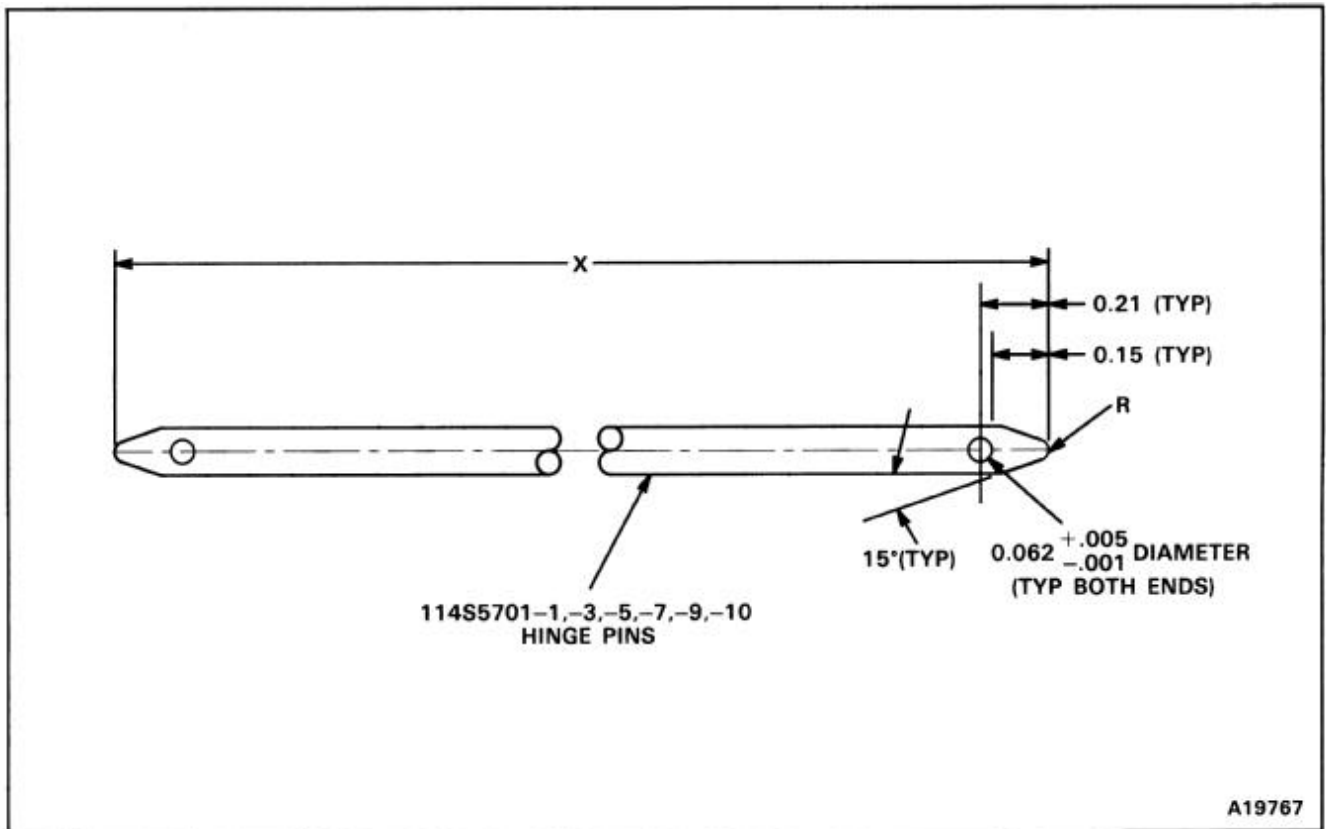

Tasks E-224 thru E-225 deleted.

END OF TASK

NOTES:

1. FABRICATE FROM ALUMINUM ALLOY CLAD SHT 2024-T3 PER QQ-A-250/5.
2. STOCK SIZE 0.040 X 3.0 X 9.5.
3. ALL DIMENSIONS IN INCHES.
4. USE ORIGINAL FORMER TO LAYOUT DIMENSIONS, BENDS, AND PILOT HOLES.
5. FINISH AS REQUIRED.

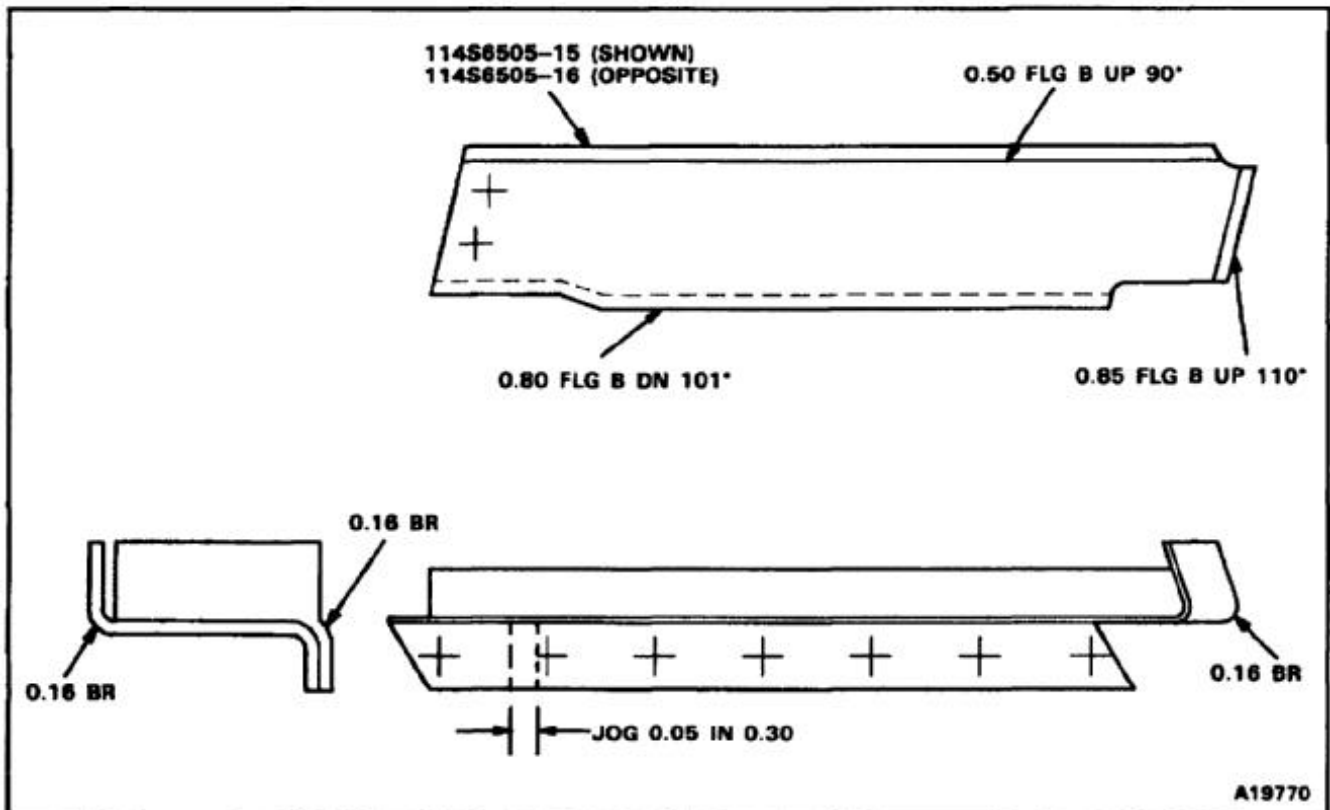

END OF TASK

NOTES:

1. FABRICATE FROM ALUMINUM ALLOY CLAD SHT 2024-T3 PER QQ-A-250/5.
2. STOCK SIZE 0.040 X 2.0 X 2.0.
3. ALL DIMENSIONS IN INCHES.
4. USE ORIGINAL CLIP AS TEMPLATE TO DETERMINE DIMENSIONS, BENDS, AND PILOT HOLES.

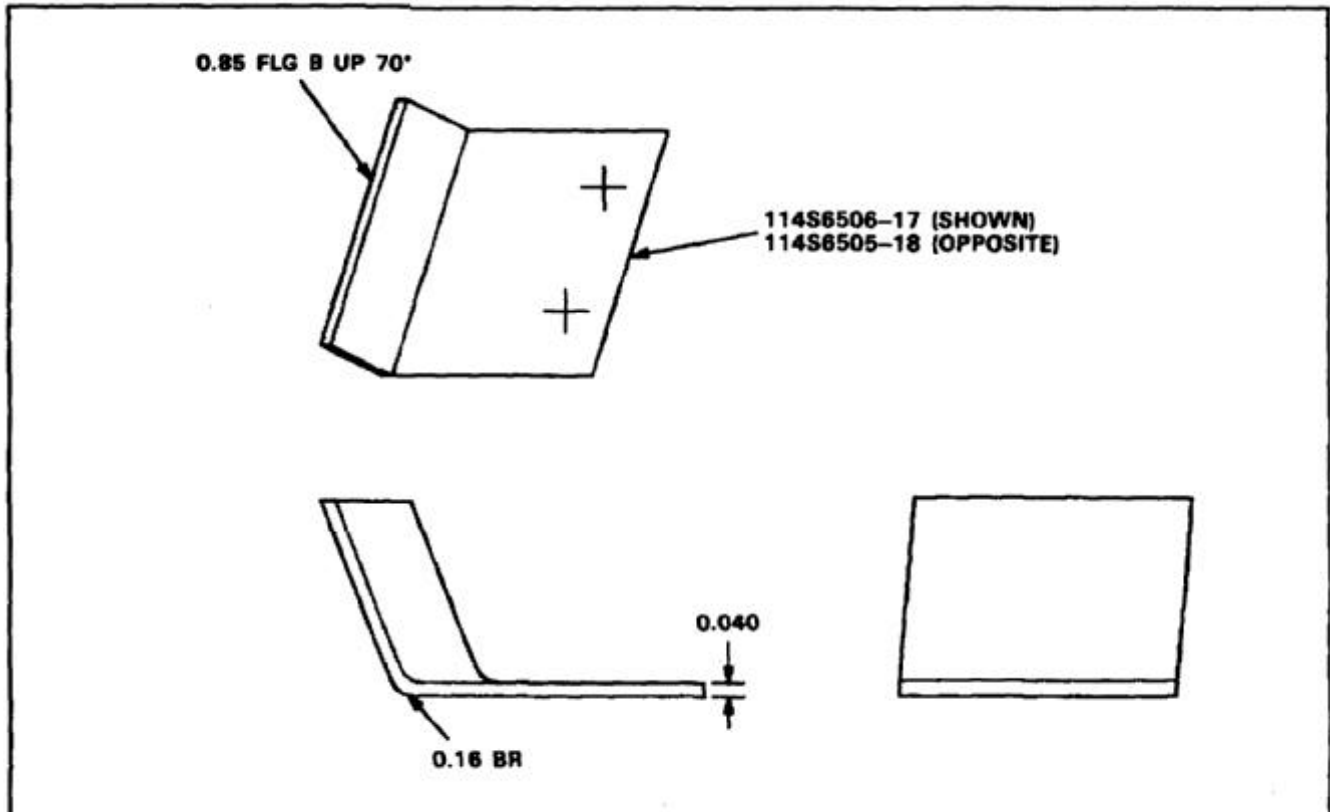

END OF TASK

NOTES:

1. ALL DIMENSIONS IN INCHES.
2. ±DIMENSION TOLERANCE 0.03.
3. BREAK ALL SHARP EDGES 0.020 RAD. MIN.

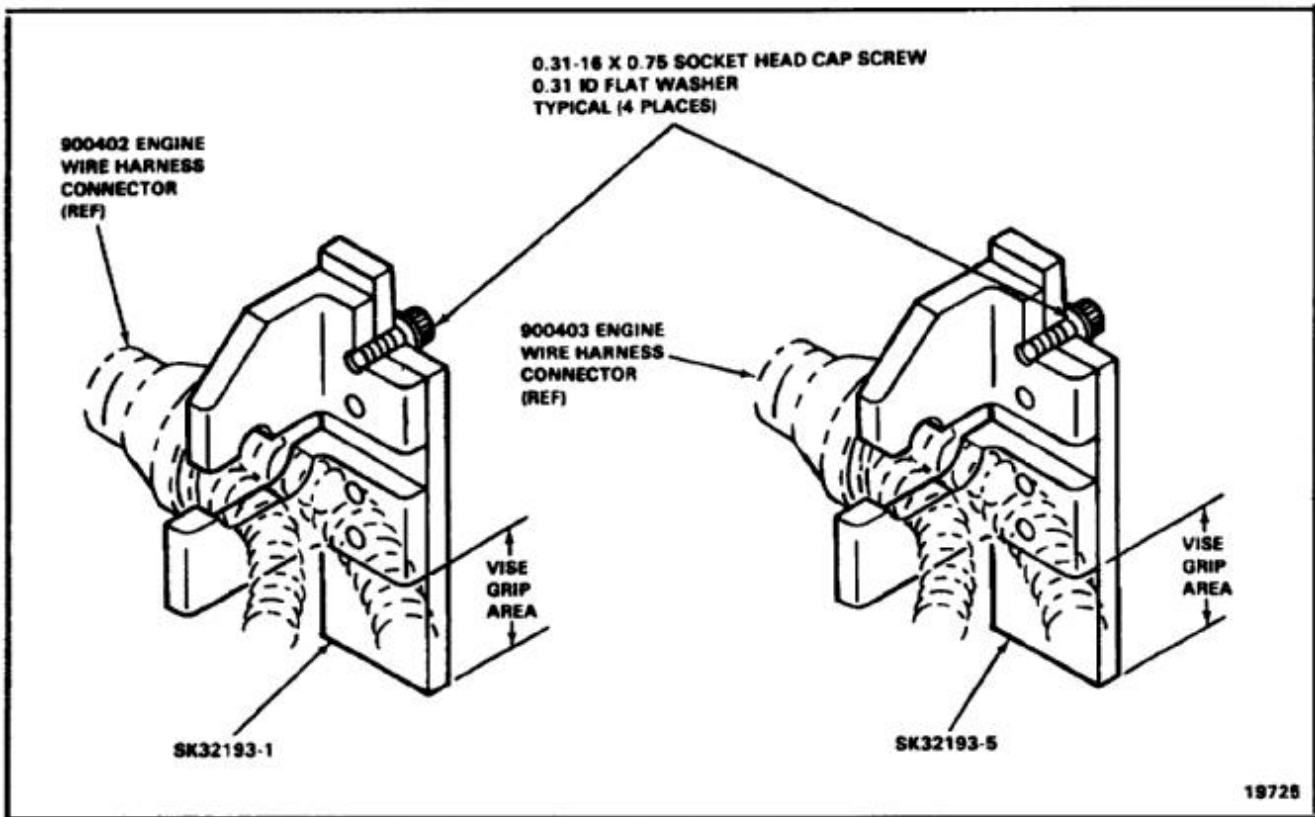

NOTES:

1. ALL DIMENSIONS IN INCHES.
2. ±DIMENSION TOLERANCE 0.03.
3. BREAK ALL SHARP EDGES 0.020 RAD. MIN.

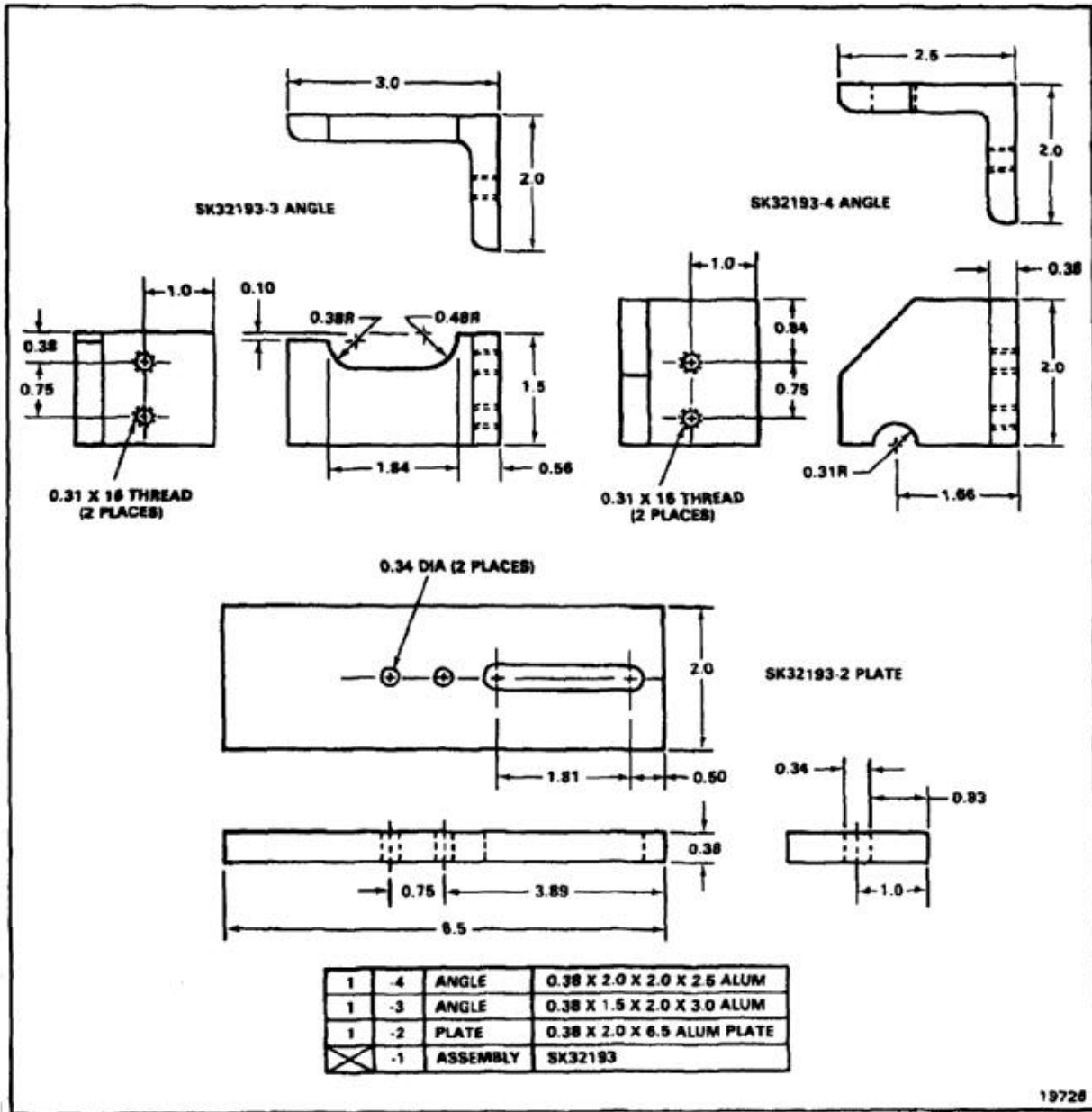

19728

NOTES:

1. FABRICATE FROM LAMINATED PHENOLIC TYPE FBM PER MIL-P-15035.
2. STOCK SIZE 0.13 X 1.0 X 2.9.
3. ALL DIMENSIONS IN INCHES.
4. FINISH AS REQUIRED.
5. USE ORIGINAL PART TO DETERMINE DIMENSION X.

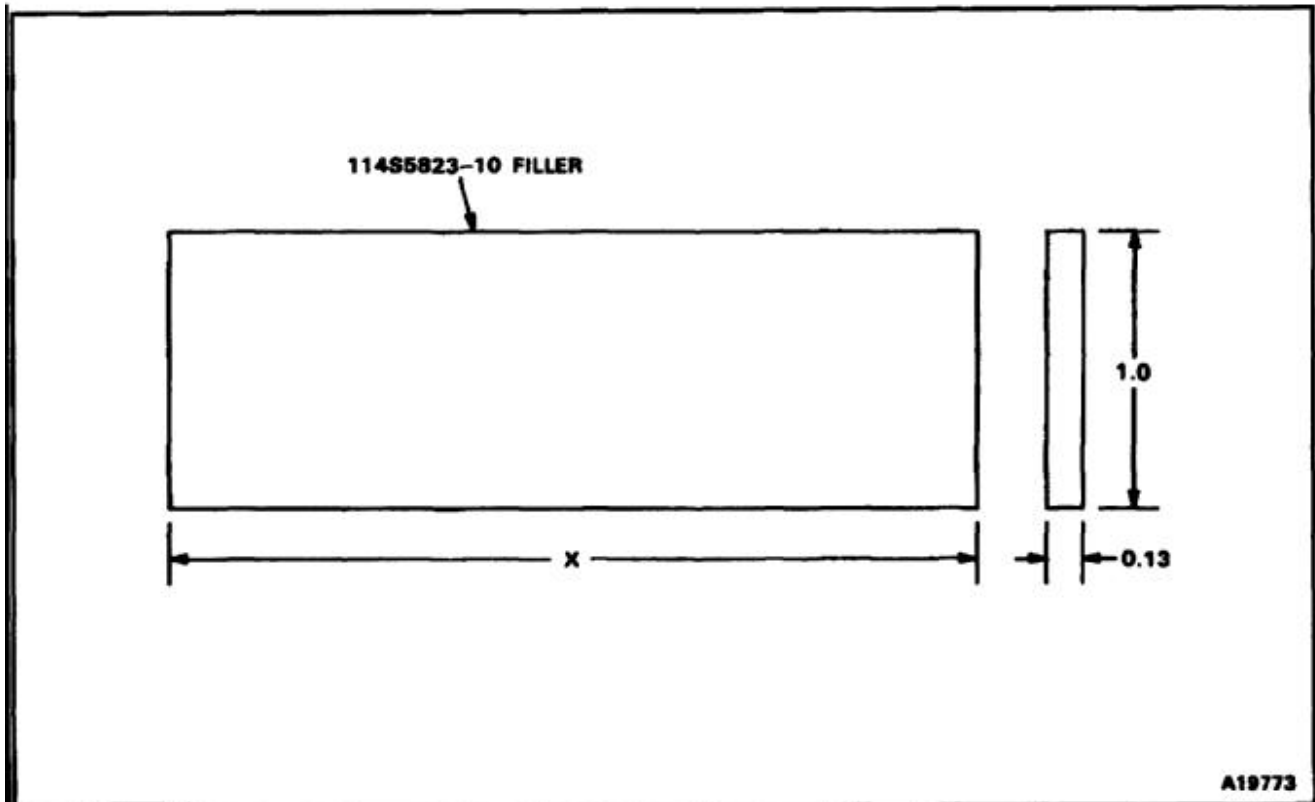

END OF TASK

NOTES:

1. FABRICATE FROM MS20001PH9-5500.
2. THE 114S5823-17 HINGE HALF IS THE OPPOSITE OF THE 114S5823-18 HINGE HALF.
3. USE ORIGINAL PART TO DETERMINE DIMENSION X AND LOCATE PILOT HOLES.
4. FINISH AS REQUIRED.

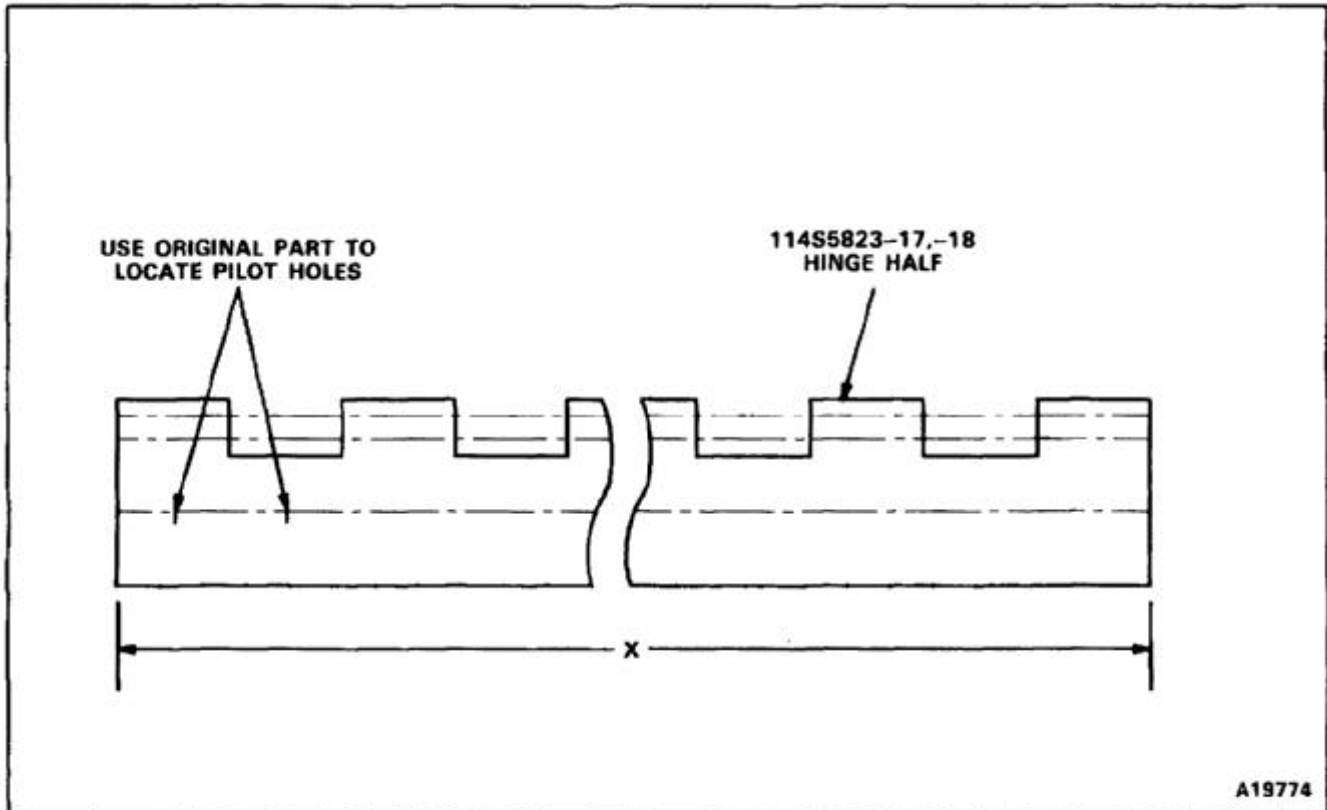

END OF TASK

NOTES:

1. USE ORIGINAL PARTS TO DETERMINE PILOT HOLE LOCATIONS, HINGE HALF, AND HINGE PIN LENGTH.
2. FINISH AS REQUIRED.
3. FABRICATE FROM:

NOMENCLATURE	PART NUMBER	MATERIAL
HINGE HALF	114S5823-19	MS20001PH5-5500
HINGE PIN	114S5823-33	MS20253-2-5500
HINGE HALF	114S5823-20	MS20001PH5-5500
HINGE HALF	11455823-21	MS20001PH5-5500
HINGE PIN	114S5823-34	MS20253-2-5500
HINGE HALF	114S5823-22	MS20001PH5-5500
HINGE HALF	114S5823-23	MS20001PH5-5500
HINGE PIN	114S5823-35	MS20253-2-5500
HINGE HALF	114S5823-24	MS20001PH5-5500

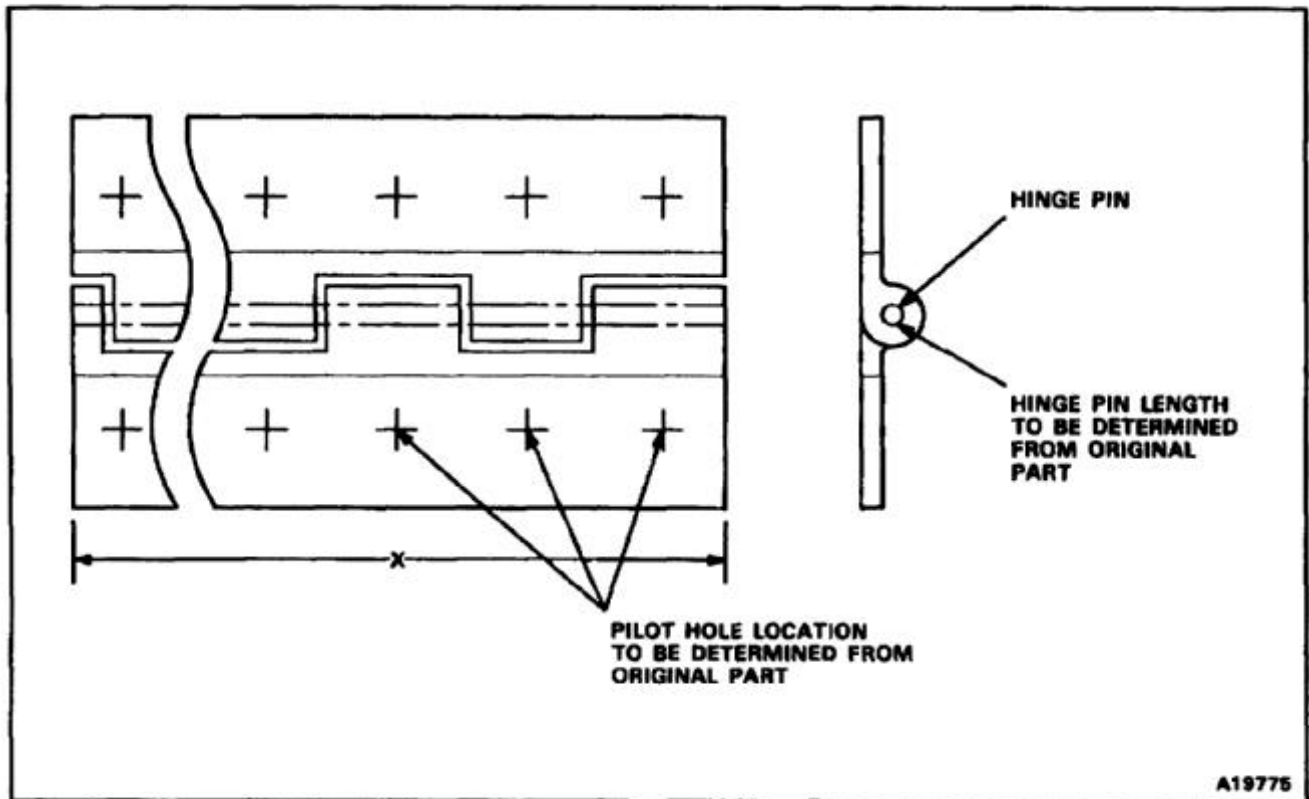

END OF TASK

NOTES:

1. FABRICATE FROM LAMINATED PHENOLIC, TYPE FBM PER MIL-P-15035.
2. STOCK SIZE 0.125 X 1.0 X 89.0.
3. ALL DIMENSIONS IN INCHES.
4. FINISH AS REQUIRED.
5. USE ORIGINAL PART TO DETERMINE DIMENSION X.

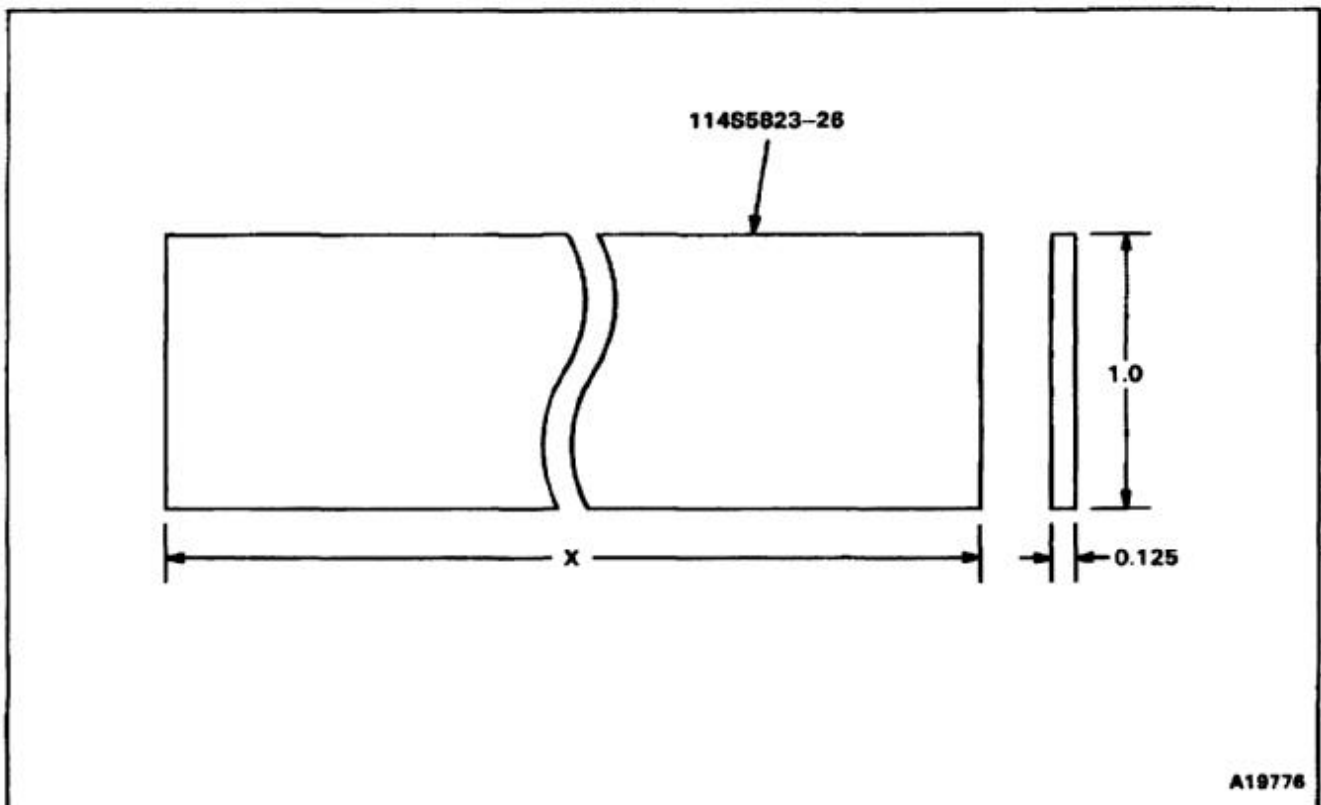

END OF TASK

E-308

NOTES:

1. FABRICATE FROM AL ALY CLAD PLATE 2024-T3 PER QQ-A-250/5.
2. STOCK SIZE 0.250 X 1.2 X 4.0.
3. ALL DIMENSIONS IN INCHES.
4. USE ORIGINAL PART TO DETERMINE DIMENSIONS X AND Y.
5. FINISH AS REQUIRED.

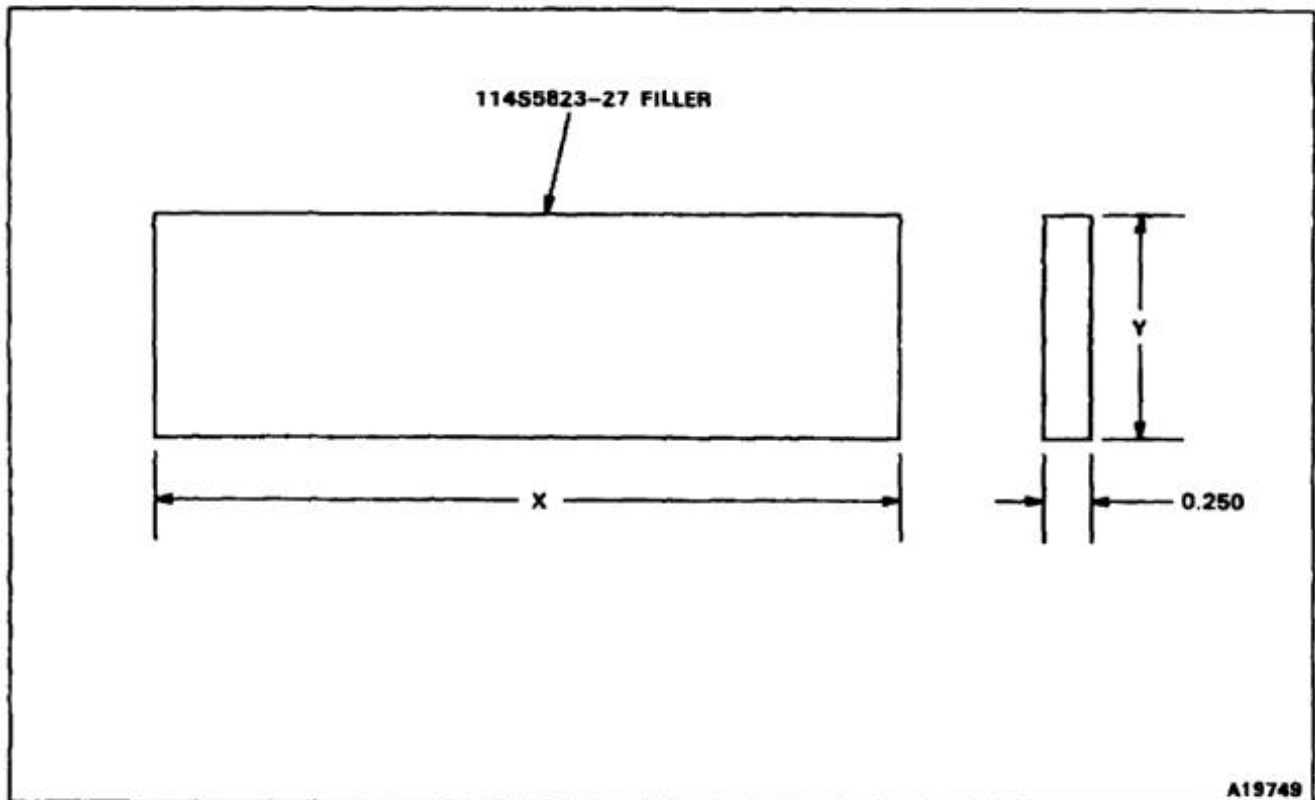

END OF TASK

NOTES:

1. FABRICATE FROM ALUMINUM ALLOY CLAD SHEET 2024-T3 PER QQ-A-250/5.
2. ALL DIMENSIONS IN INCHES.
3. FINISH AS REQUIRED.
- 4.

STOCK SIZE

PART NO.	X DIM.	Y DIM.	Z DIM.
114S5823-31	88.0	0.063	2.1
114S5823-32	104.6	0.063	1.3

5. USE ORIGINAL PART TO DETERMINE DIMENSIONS X AND Y.

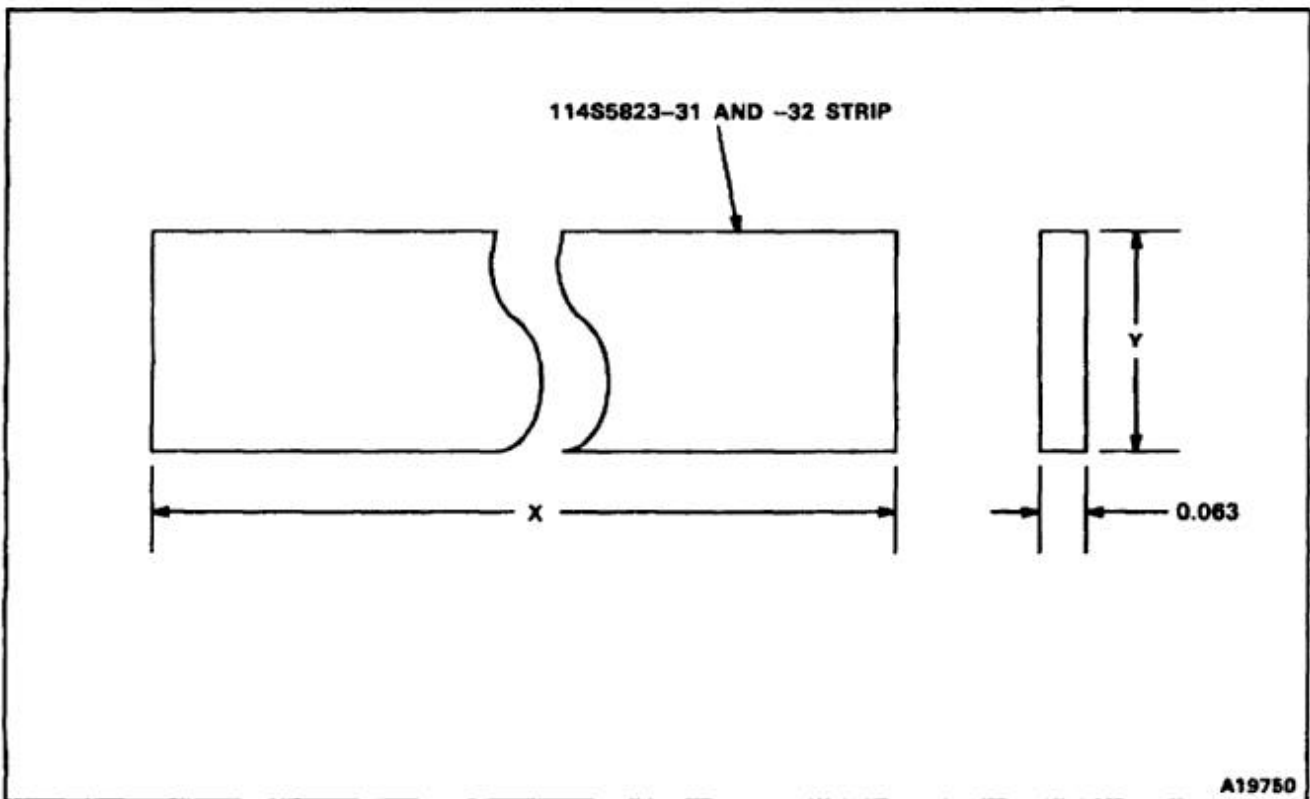

A19750

END OF TASK

NOTES:

1. FABRICATE FROM LAMINATED PHENOLIC, TYPE FBM PER MIL-P-15035.
2. STOCK SIZE 0.19 X 1.2 X 2.8.
3. ALL DIMENSIONS IN INCHES.
4. USE ORIGINAL PART TO DETERMINE DIMENSIONS X, Y, AND Z.
5. FINISH AS REQUIRED.

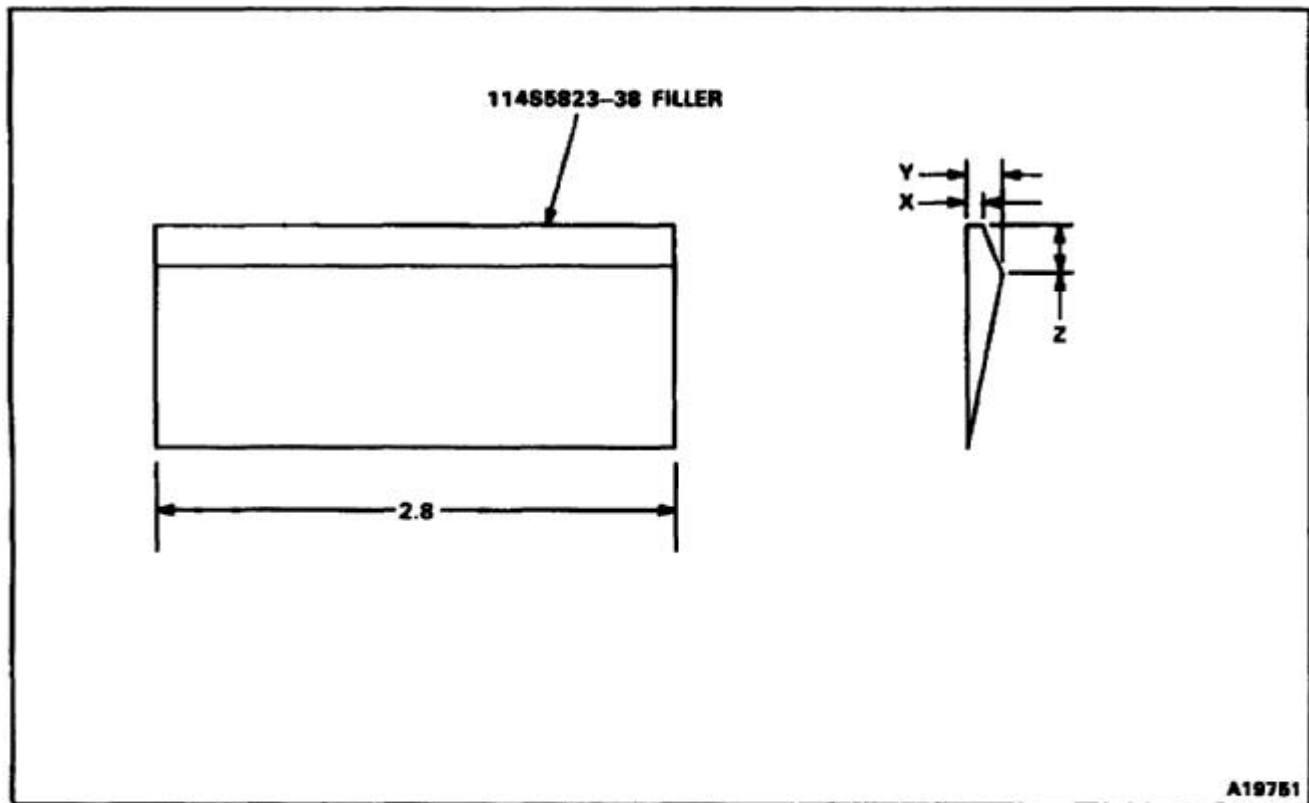

END OF TASK

NOTES:

1. FABRICATE FROM MS20001PH9-5300.
2. USE ORIGINAL PART TO DETERMINE DIMENSION X AND LOCATE PILOT HOLES.
3. FINISH AS REQUIRED.

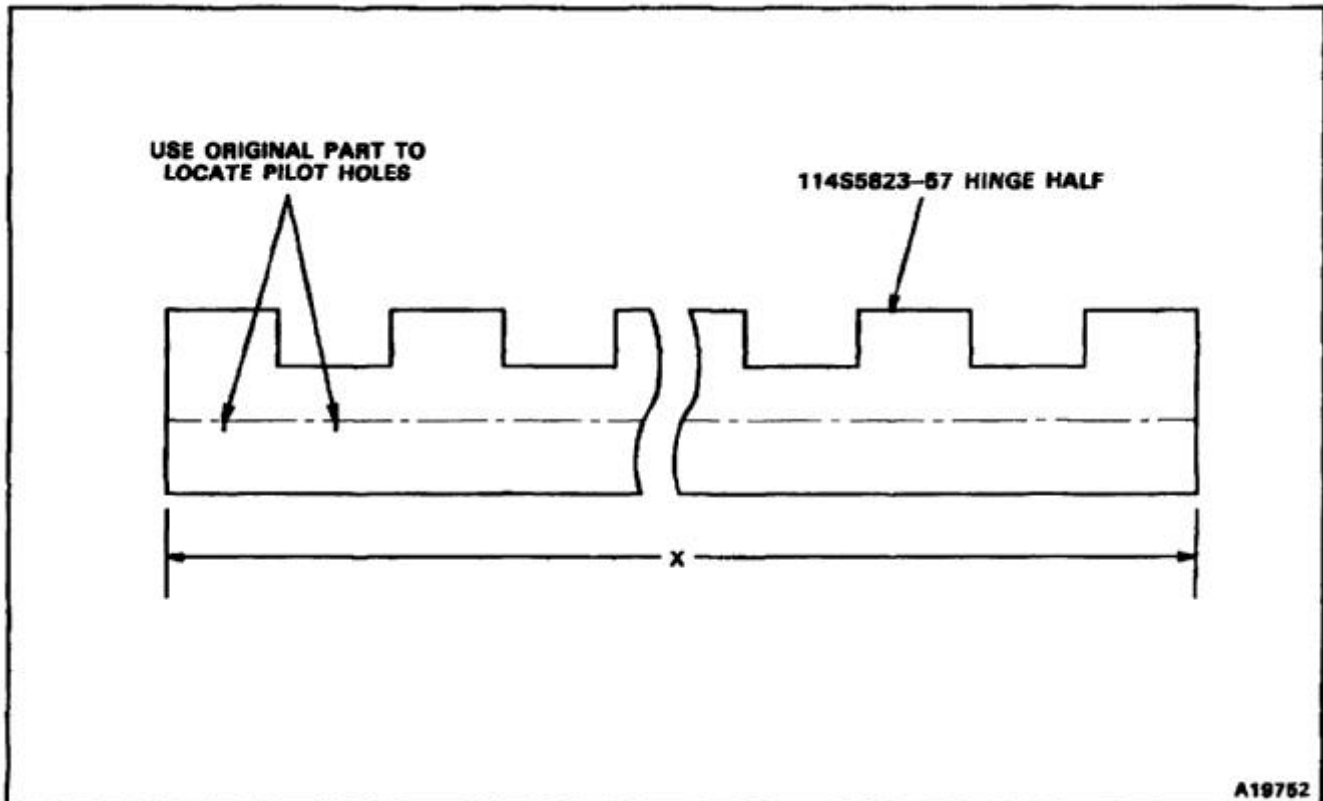

END OF TASK

E-312

NOTES:

1. FABRICATE FROM M520001PH5-5300.
2. USE ORIGINAL PART TO DETERMINE DIMENSION X AND LOCATE PILOT HOLES.
3. FINISH AS REQUIRED.

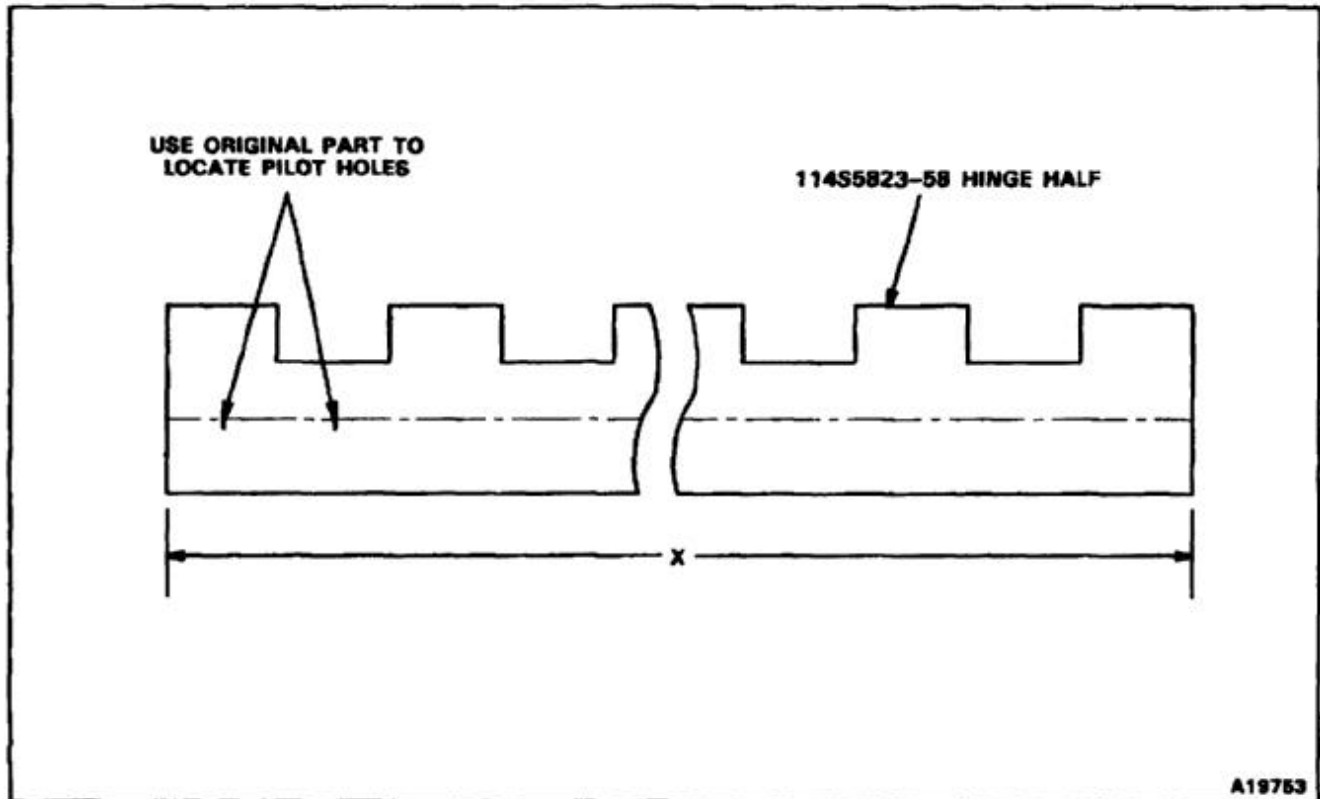

END OF TASK

NOTES:

1. FABRICATE FROM MS20253-2-5300.
2. USE ORIGINAL PART TO DETERMINE DIMENSION X.
3. FINISH AS REQUIRED.

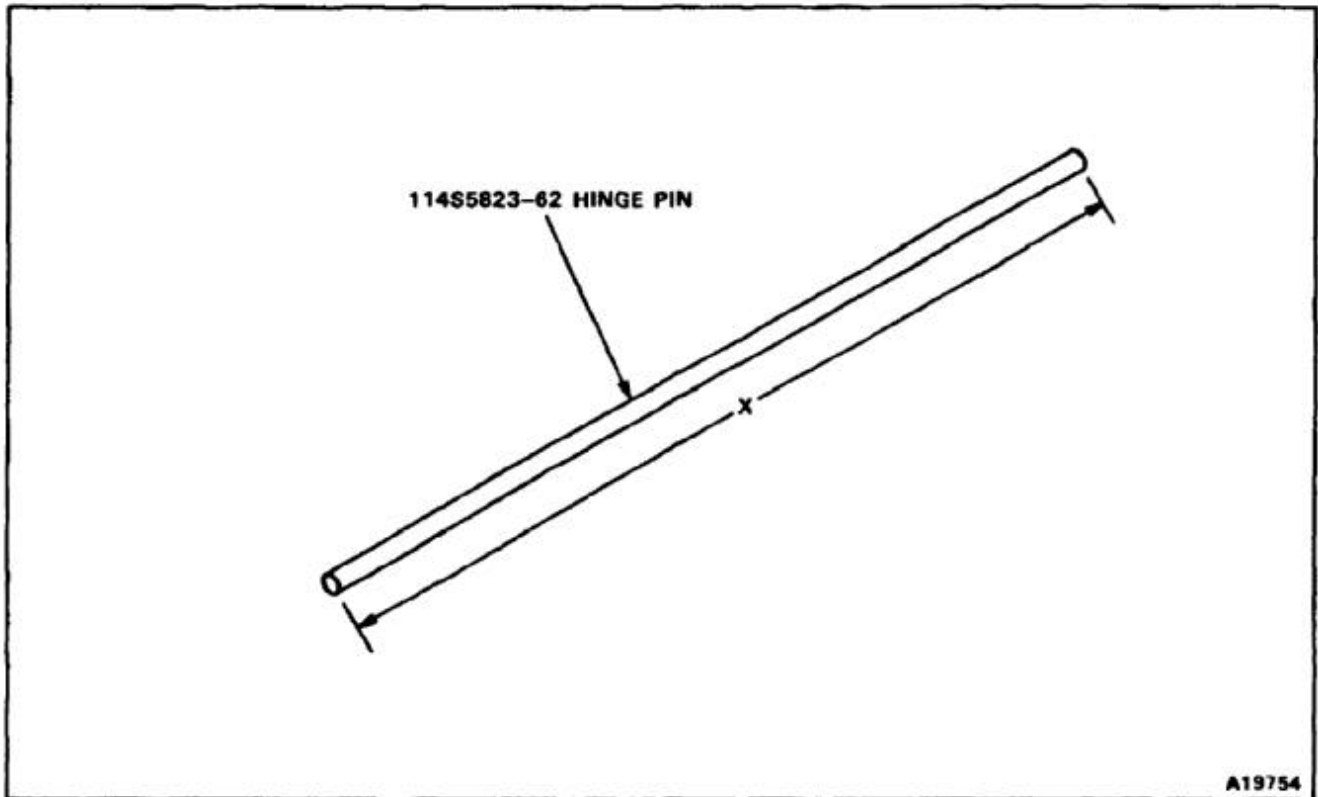

END OF TASK

NOTES:

1. FABRICATE FROM MIL-P-15035 LAMINATED PHENOLIC, TYPE FBM.
2. STOCK SIZE 0.1 X 1.3 X 26.5.
3. ALL DIMENSIONS IN INCHES.
4. COORDINATE PILOT HOLE LOCATION WITH THE 114S5824-12 HINGE HALF.
5. USE ORIGINAL PART TO DETERMINE DIMENSION X.
6. FINISH AS REQUIRED.

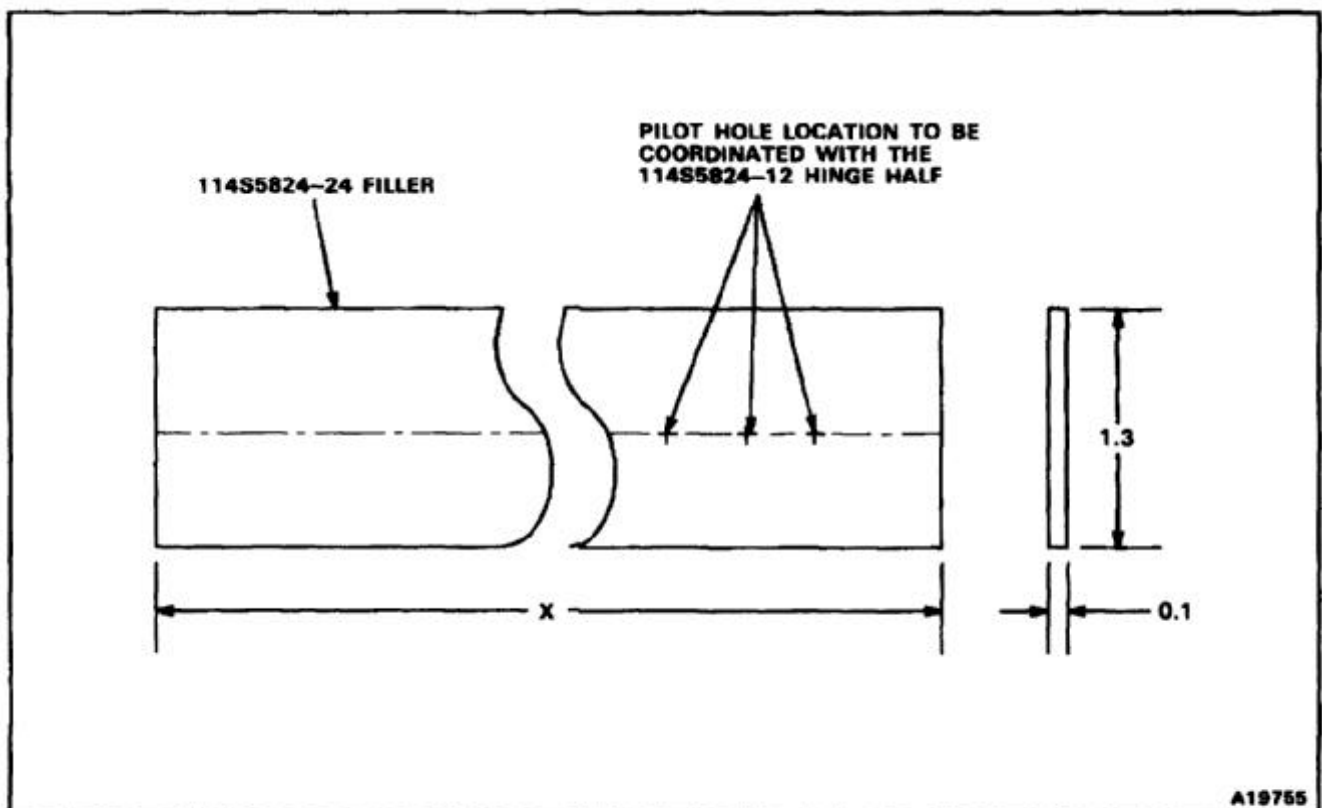

END OF TASK

NOTES:

1. FABRICATE FROM LAMINATED PHENOLIC TYPE FBM PER MIL-P-15035.
2. STOCK SIZE 0.12 X 1.1 X 7.9.
3. ALL DIMENSIONS IN INCHES.
4. FINISH AS REQUIRED.

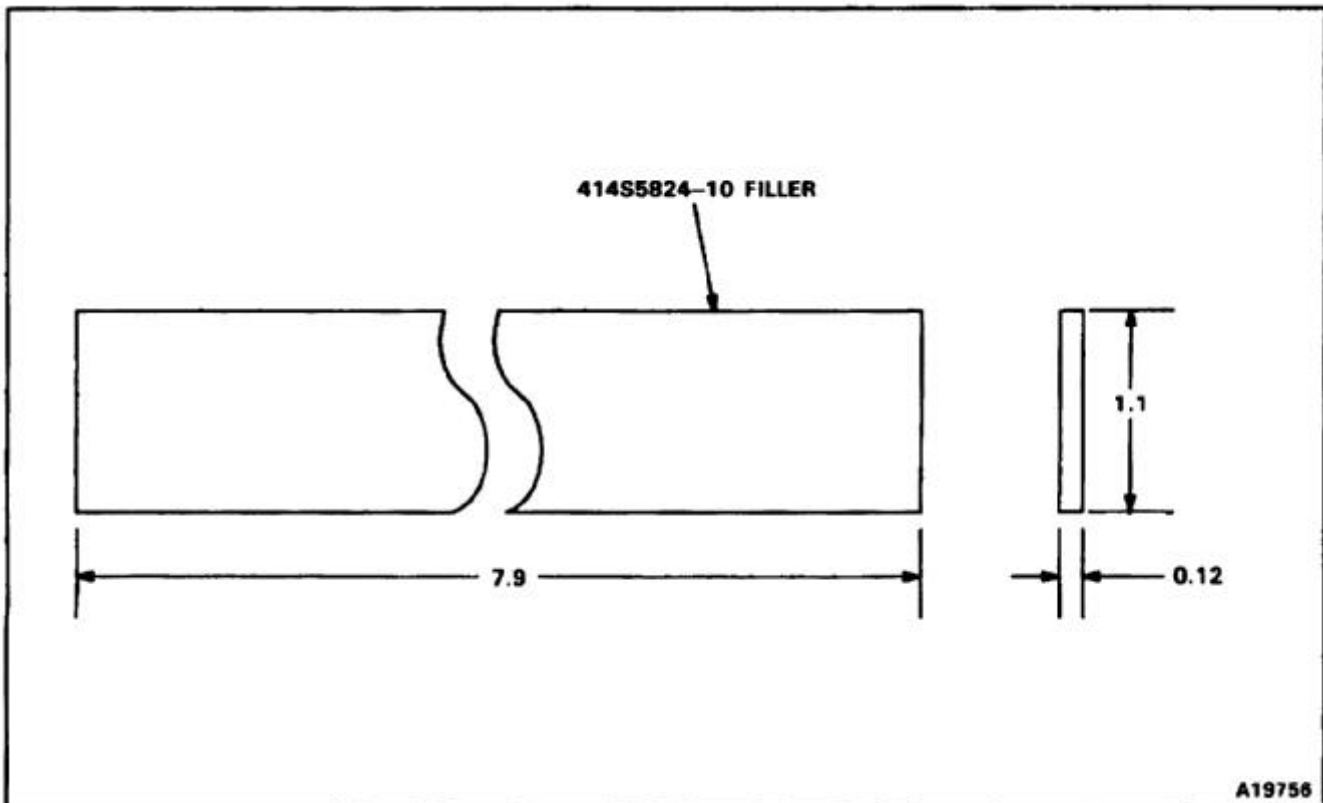

END OF TASK

NOTES:

1. FABRICATE FROM ALUMINUM ALLOY CLAD SHEET 2024-T3 PER QQ-A-250/5.
2. STOCK SIZE 0.050 X 1.7 X 23.3.
3. ALL DIMENSIONS IN INCHES.
4. USE ORIGINAL STRIP FOR PILOT HOLE LOCATIONS.

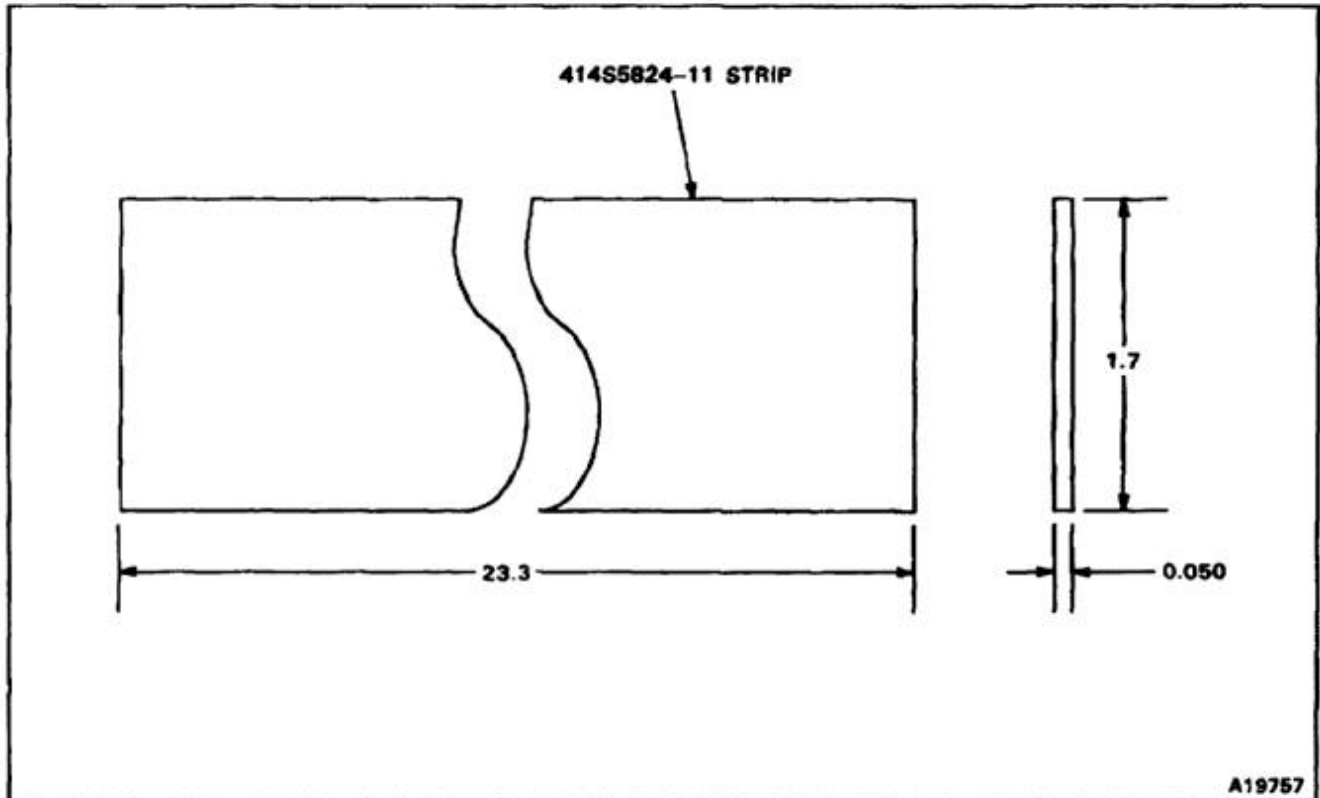

END OF TASK

NOTES:

1. FABRICATE FROM LAMINATED PHENOLIC, TYPE FBM PER MIL-P-15035.
2. STOCK SIZE 0.2 X 1.1 X 23.3.
3. ALL DIMENSIONS IN INCHES.
4. FINISH AS REQUIRED.

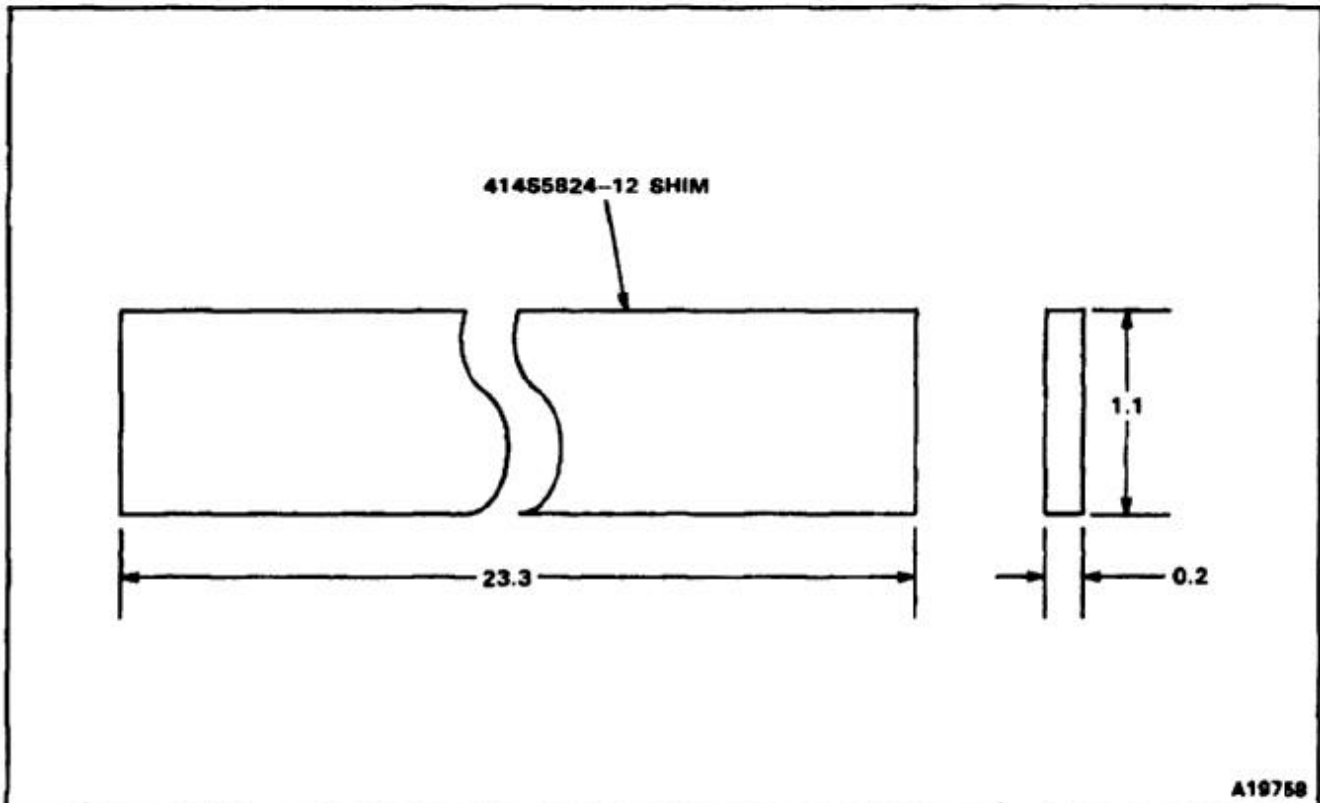

END OF TASK

NOTES:

1. FABRICATE FROM RUBBER HOSE MIL-R-6855, CLASS II, GRADE 60.
2. ALL DIMENSIONS IN INCHES.
3. CUT TO SPECIFIED LENGTHS.
4. NOMINAL OUTSIDE DIAMETER TO BE 0.688, WITH A NOMINAL WALL THICKNESS OF 0.188.
- 5.

PART NUMBER	ID	LENGTH
114S2610-31	0.312	15.1
114S2610-74	0.312	28.0

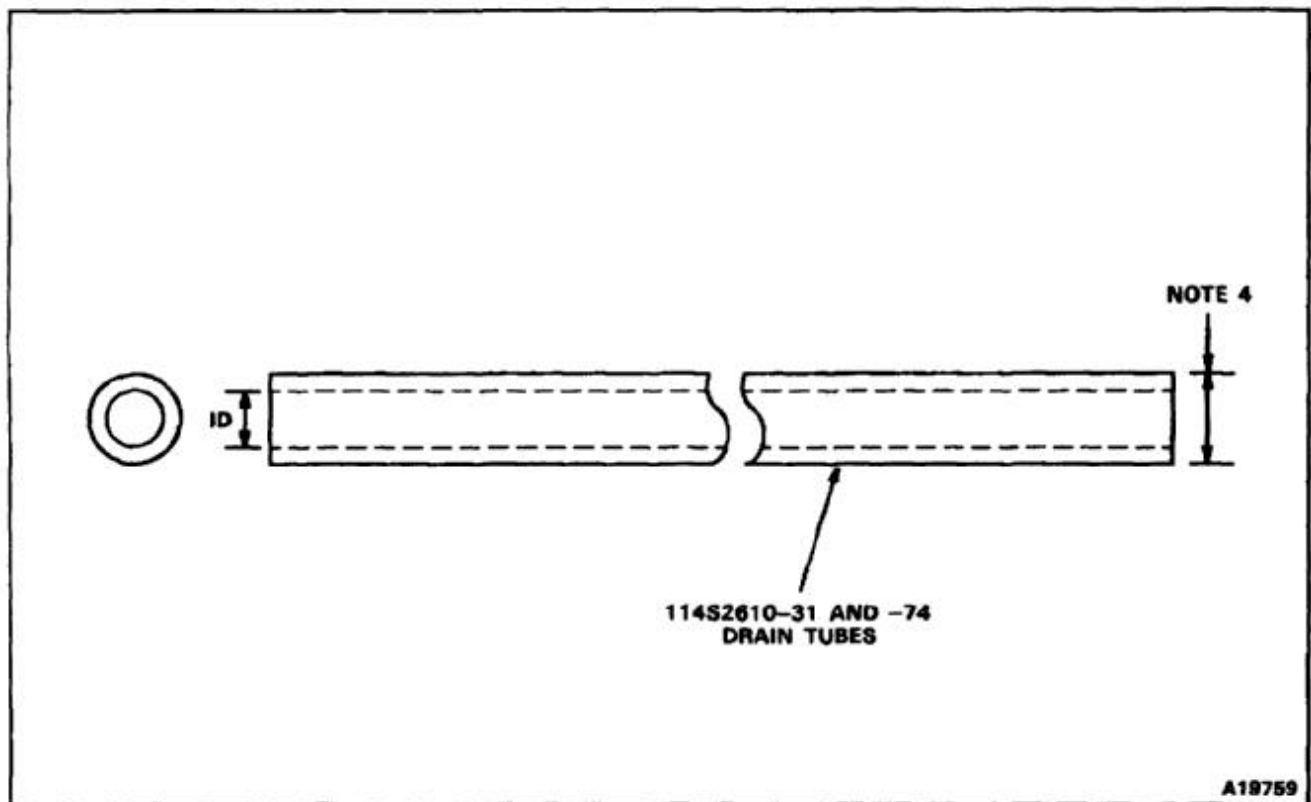

END OF TASK

NOTES:

1. FABRICATE FROM AND 10133-1201 AL ALY EXTRUSION 7075-T6 PER QQ-A-277.
2. USE ORIGINAL CLIP TO DETERMINE PILOT HOLES AND DIMENSION X.
3. FINISH AS REQUIRED.

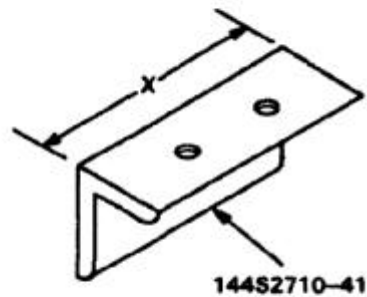

A18780

END OF TASK

E-320

NOTES:

1. FABRICATE FROM VS90415 ALUMINUM EXTRUSION 6061-T6 PER QQ-A-270 CUT TO THE FOLLOWING LENGTHS:

PART NUMBER	LENGTH
114S6608-15	132
114S6608-25 AND -26	84

2. FINISH AS REQUIRED.
3. ALL DIMENSIONS IN INCHES.

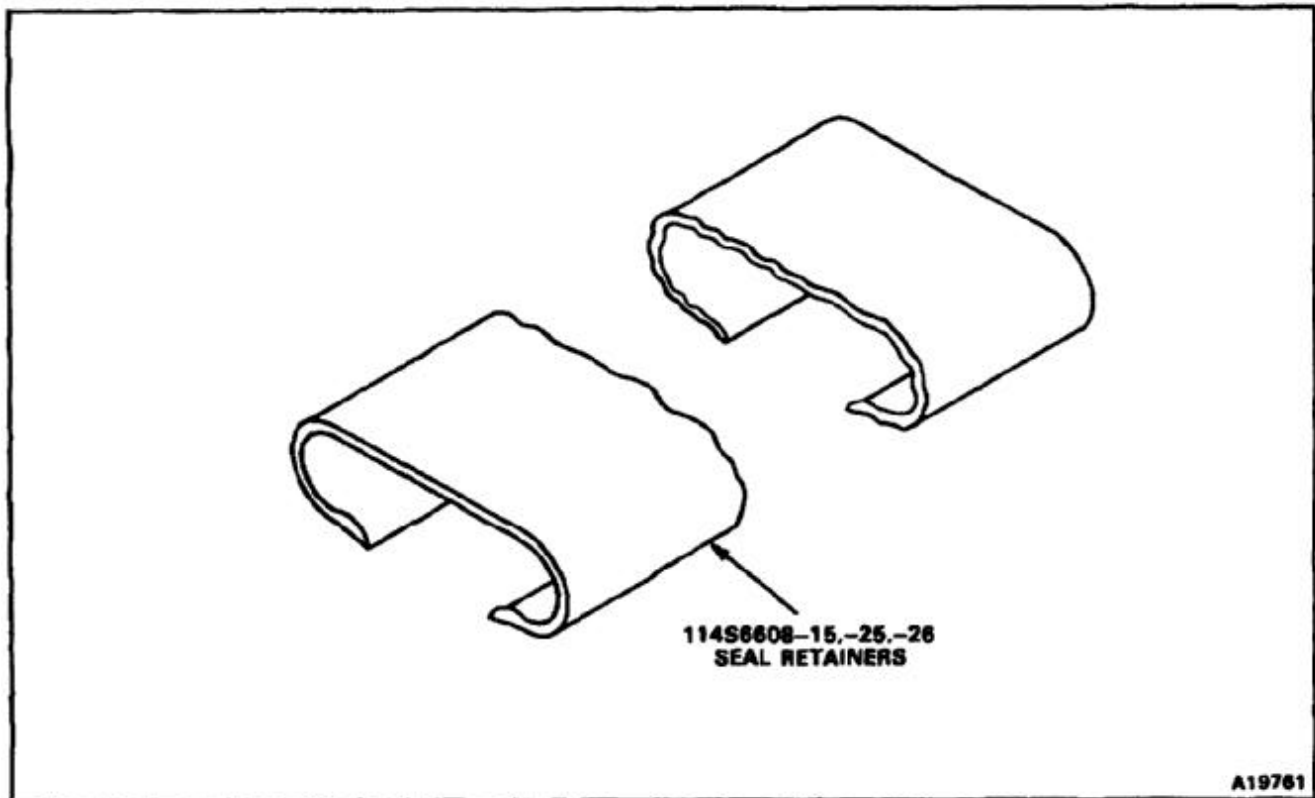

END OF TASK

NOTES:

1. FABRICATE FROM RECTANGULAR BAR STOCK 2024-T4 PER QQ-A-268.
2. STOCK SIZE 0.125 X 1.0 X 1.0.
3. ALL DIMENSIONS IN INCHES.
4. FINISH AS REQUIRED.

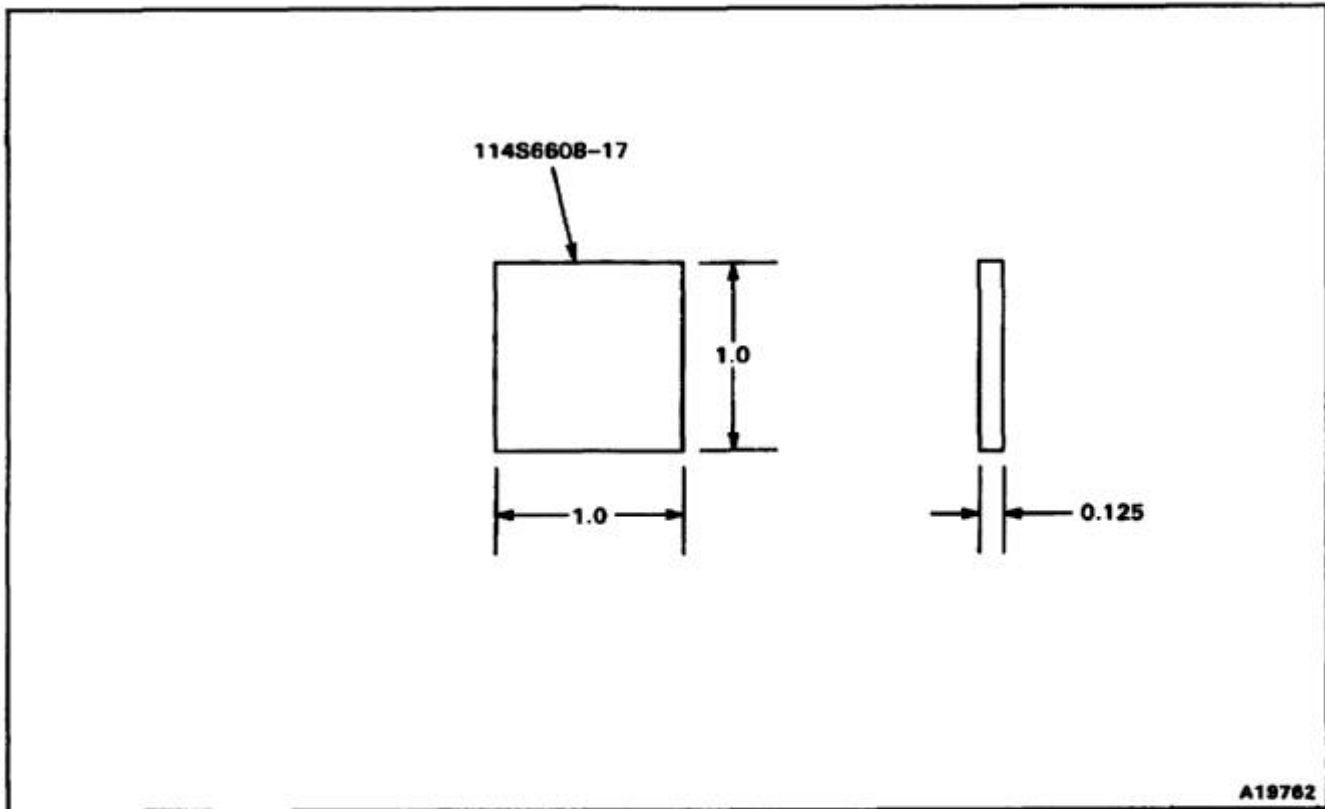

END OF TASK

E-322

NOTES:

1. FABRICATE FROM CLAD SHEET 2024-T4 PER QQ-A-362.
2. CUT TO DIMENSIONS SHOWN. STOCK SIZE 0.040 X 2.0 X 1.0.
3. ALL DIMENSIONS IN INCHES.
4. FINISH AS REQUIRED.

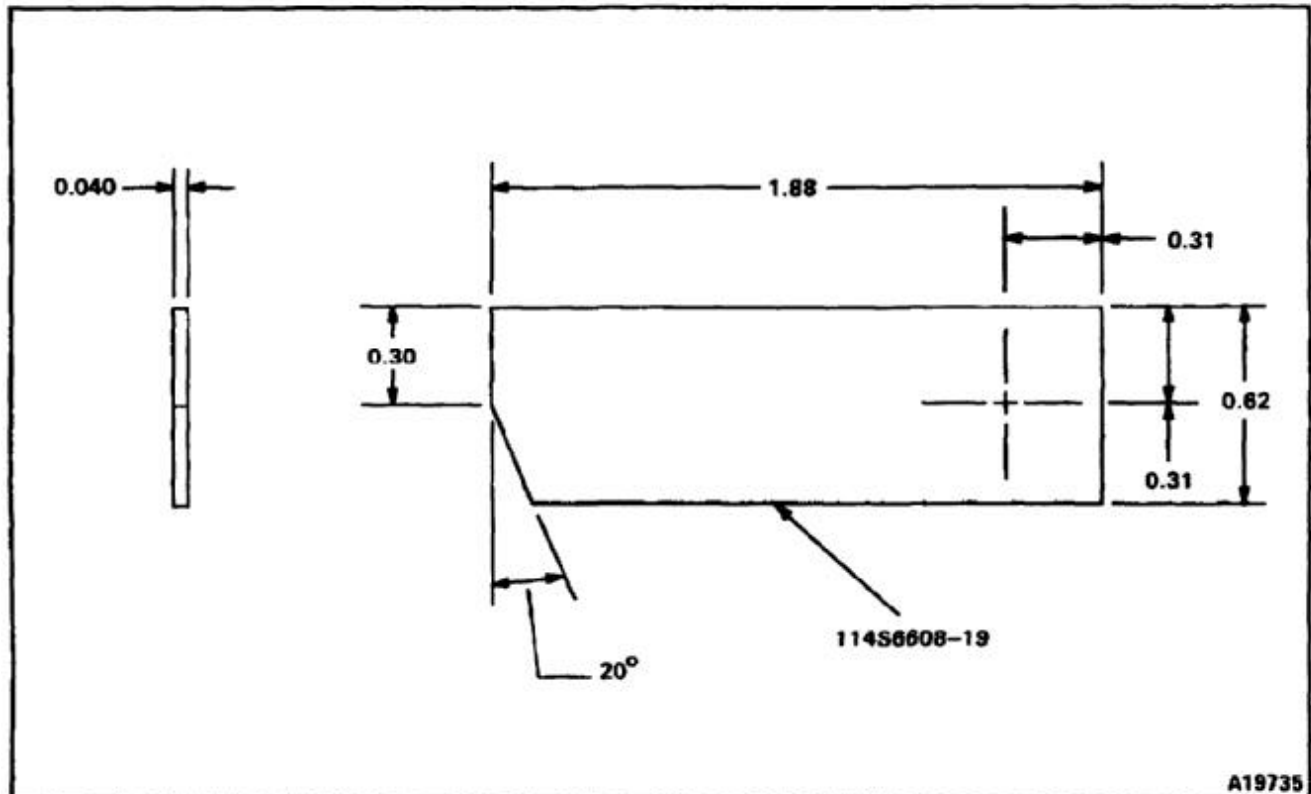

END OF TASK

NOTES:

1. FABRICATE FROM AL ALY CLAD SHEET 2024-T4 PER QQ-A-362.
2. CUT AND FORM TO THE DIMENSIONS SHOWN.
3. ALL DIMENSIONS IN INCHES.
4. FINISH AS REQUIRED.

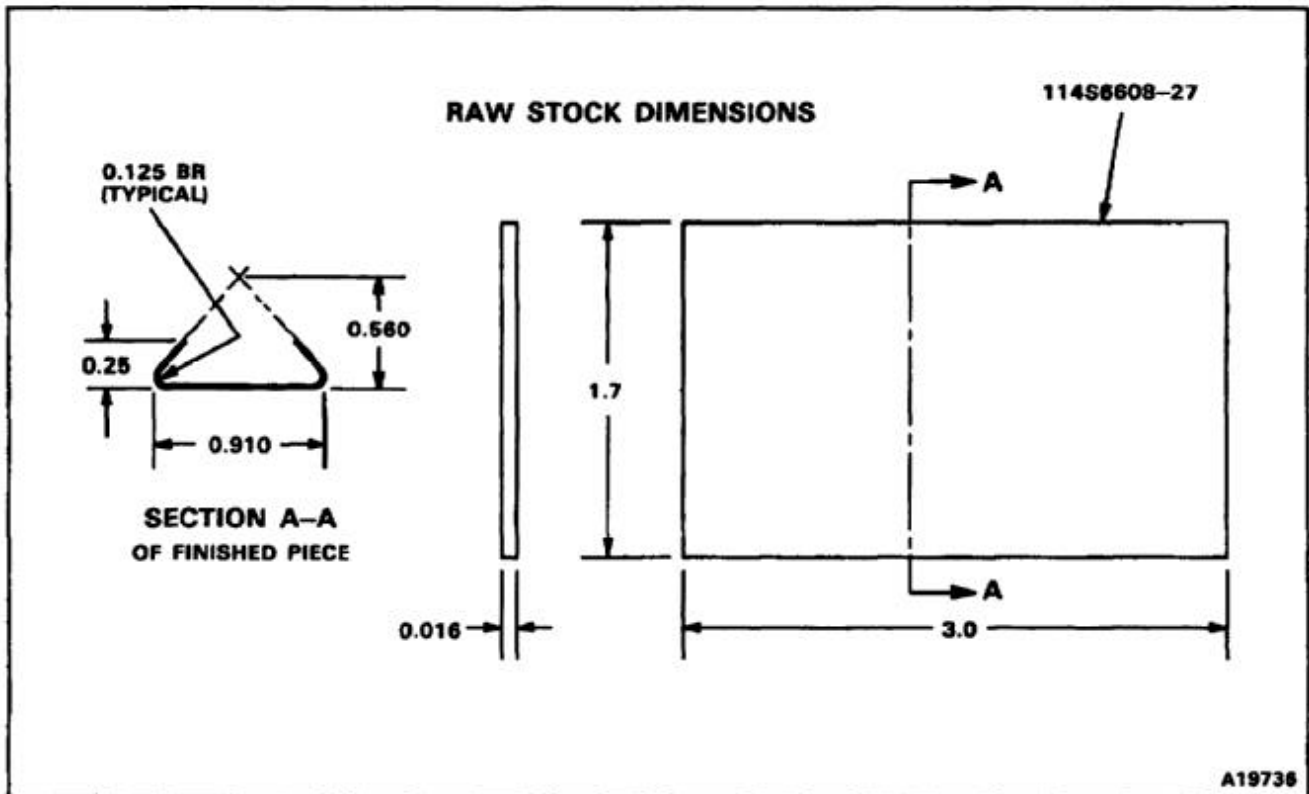

END OF TASK

NOTES:

1. FABRICATE FROM VS80550-2 RUBBER EXTRUSION.
2. STOCK SIZE 15.2 INCHES.
3. ALL DIMENSIONS IN INCHES.
4. USE ORIGINAL PART TO DETERMINE DIMENSION X.

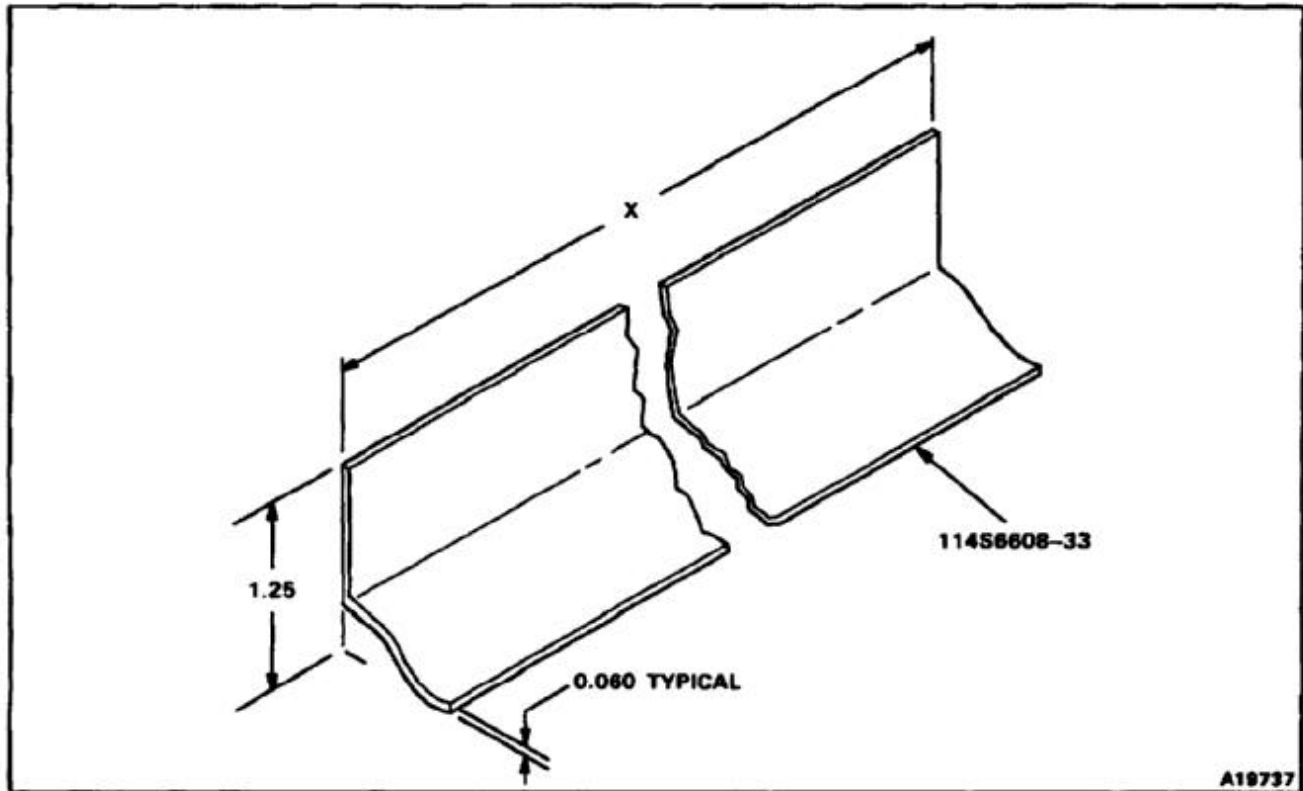

END OF TASK

NOTES:

1. FABRICATE FROM AL ALY CLAD SHEET 2024-T4 PER QQ-A-362.
2. STOCK SIZE 0.025 X 0.62 X 15.2.
3. ALL DIMENSIONS IN INCHES.
4. USE ORIGINAL PART TO DETERMINE DIMENSIONS X AND Y.
5. FINISH AS REQUIRED.

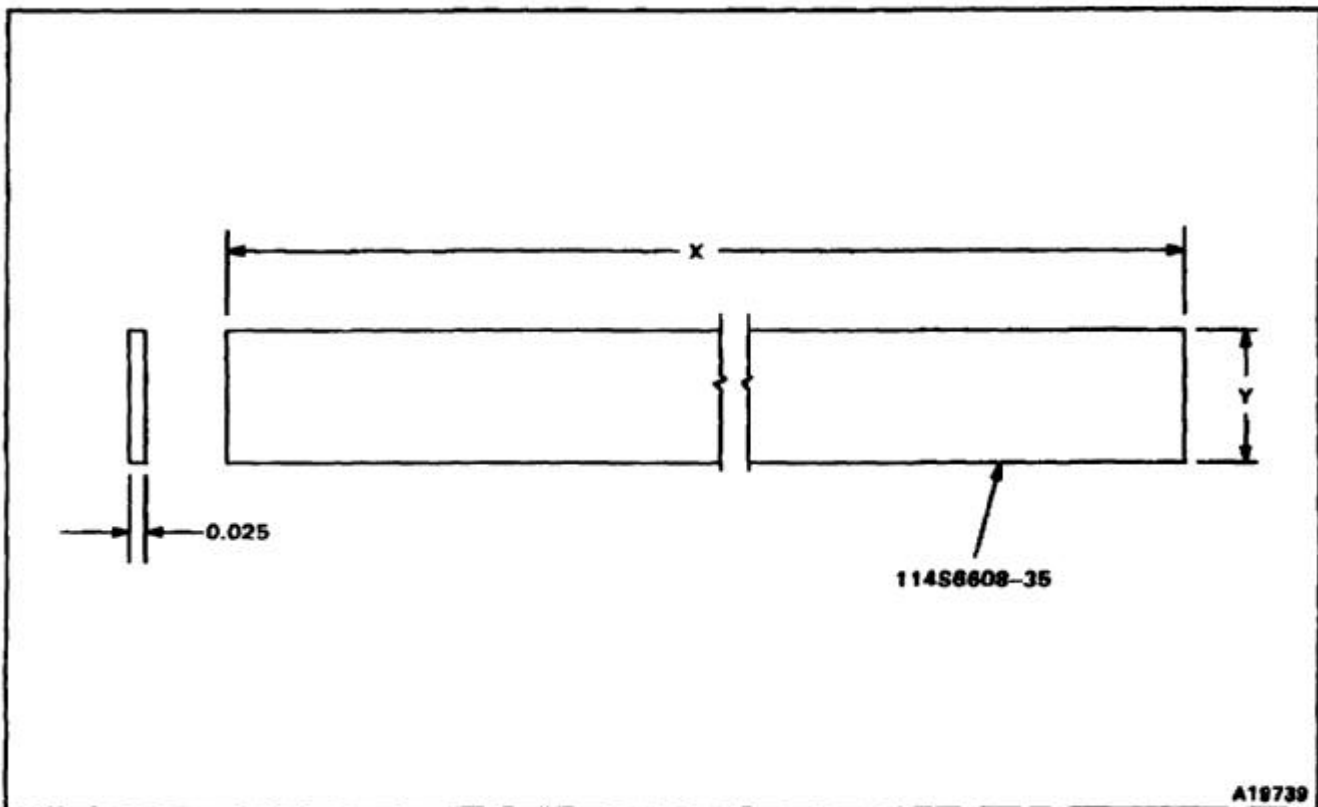

END OF TASK

NOTES:

1. FABRICATE HINGE PIN FROM MS20253-P2
NSN 5340-00-043-3723.
2. ALL DIMENSIONS IN INCHES.
3. CUT PINS TO LENGTH AND ROUND ENDS.
REMOVE ALL BURRS AND SHARP EDGES.
FINISH AS REQUIRED.
4. HINGE PIN LENGTHS:
114S3613-39 49.3
114S3613-43 48.8
114S3613-41 48.8

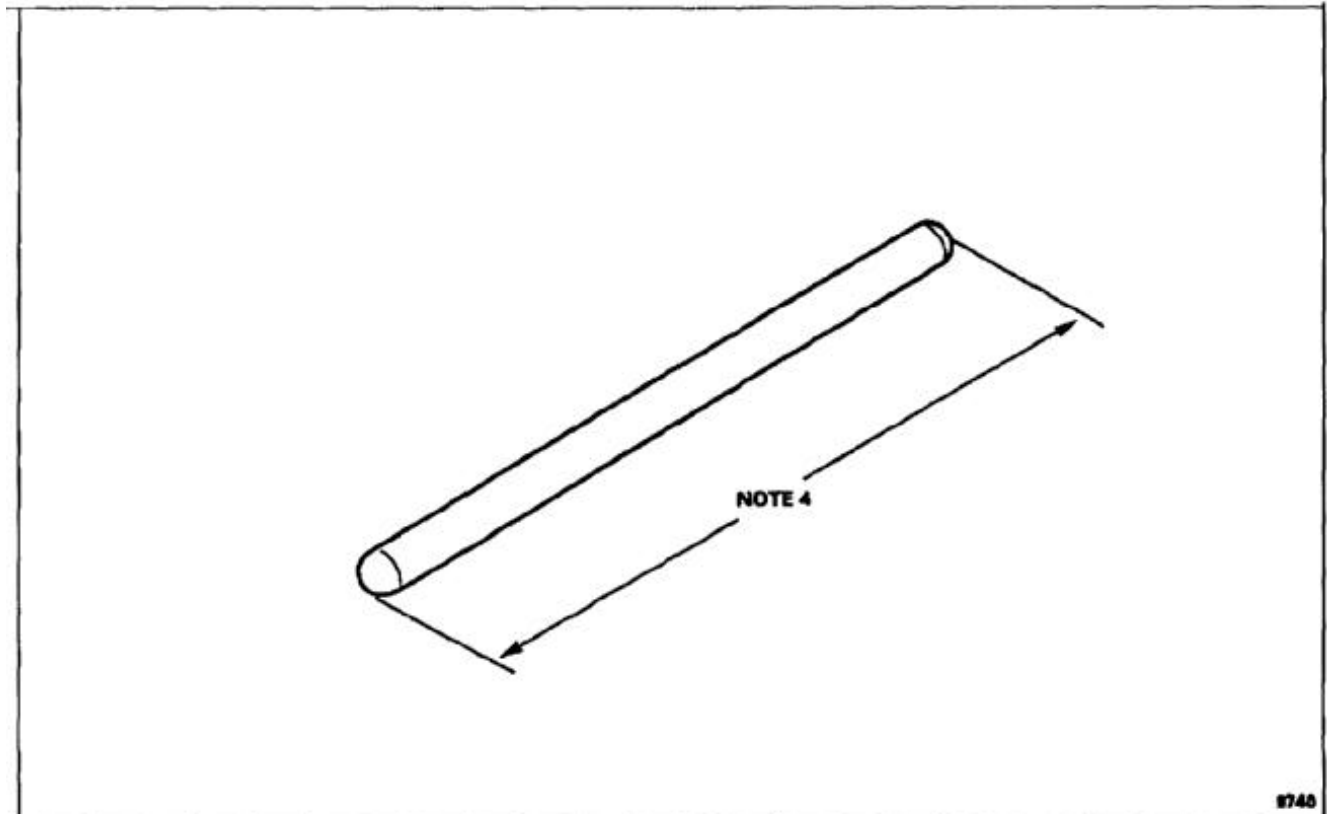

8740

END OF TASK

NOTES:

1. FABRICATE FROM MS20001PH9-7200,
NSN 5340-00-807-1070.
2. ALL DIMENSIONS IN INCHES.
3. USE ORIGINAL HINGE AS A TEMPLATE FOR
PILOT HOLES.
4. FINISH AS REQUIRED.

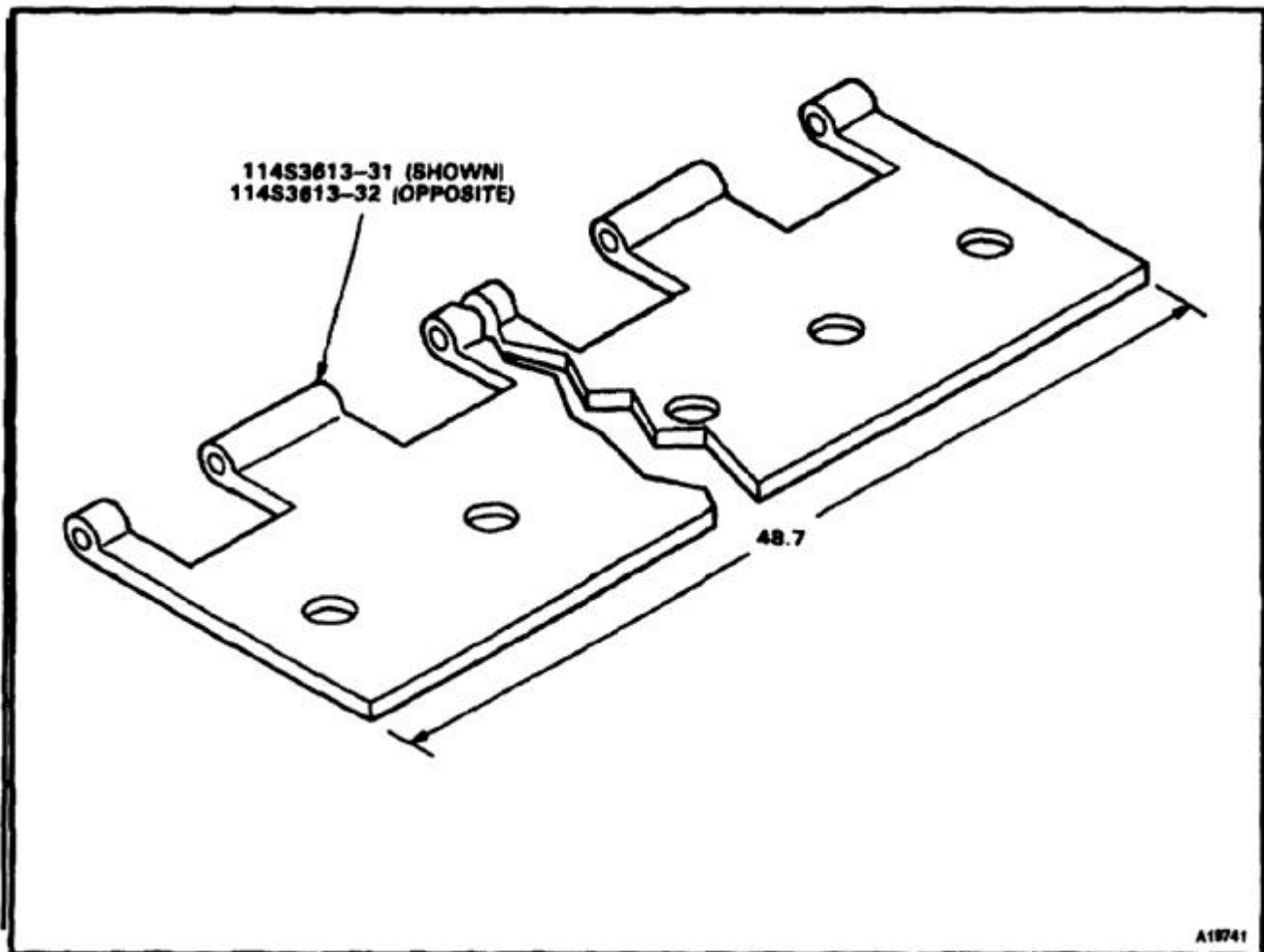

END OF TASK

E-328

NOTES:

1. FABRICATE FROM VS20106-1 AL ALY EXTRUSION 2024-T4 ALCOA 137692 PER QQ-A-267 TO DIMENSIONS SPECIFIED IN NOTE 3.
2. ALL DIMENSIONS IN INCHES.
- 3.

PART NUMBER	MATERIAL	LENGTH
11483613-35 AND -36	VS20106-1	49.0
11483613-37 AND -38	VS20106	48.7

4. USE ORIGINAL HINGE AS A TEMPLATE FOR PILOT HOLES.
5. FINISH AS REQUIRED.

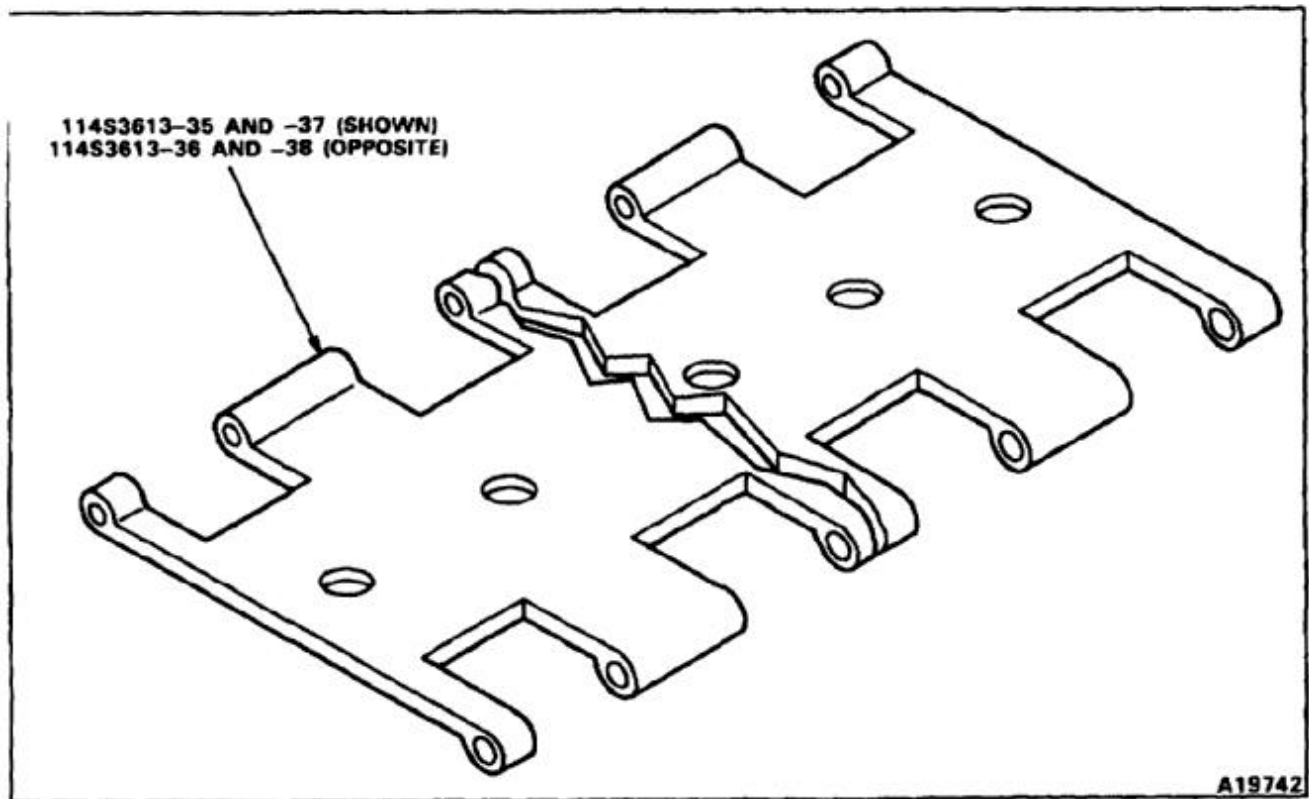

END OF TASK

NOTES:

1. FABRICATE FROM VS90540 MAGNESIUM ALLOY EXTRUSION ZK60A-T5 PER QQ-M-31.
2. STOCK SIZE 91.4 INCHES.
3. USE ORIGINAL PANEL AS TEMPLATE. CUT AND DRILL NEW PANEL TO MATCH.
4. FINISH AS REQUIRED.

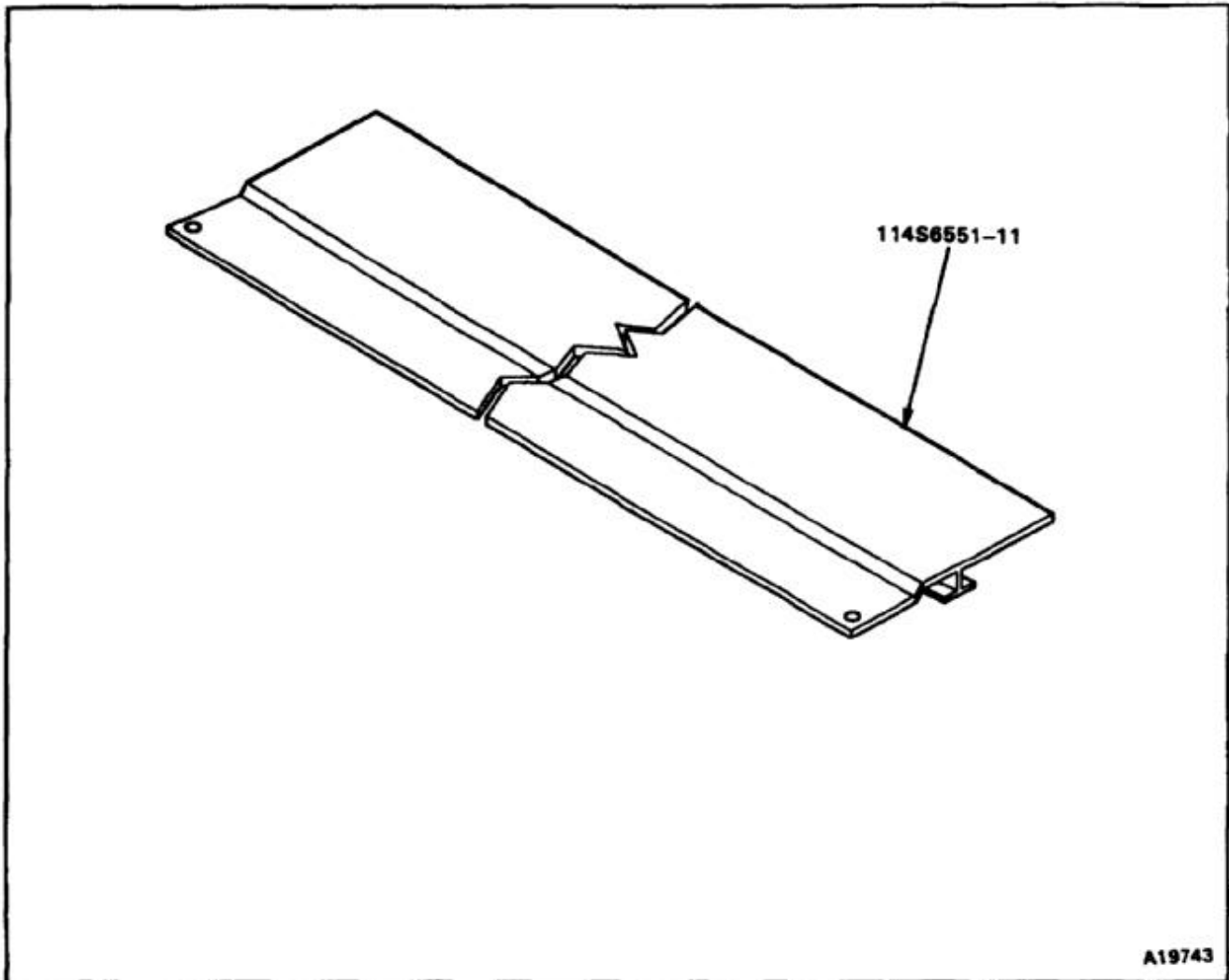

END OF TASK

E-330

NOTES:

1. FABRICATE FROM VS90578 MAGNESIUM ALLOY EXTRUSION ZK60A-T5 PER QQ-M-31.
2. STOCK SIZE 91.4 INCHES.
3. USE ORIGINAL PANEL AS TEMPLATE. CUT AND DRILL NEW PANEL TO MATCH.
4. FINISH AS REQUIRED.

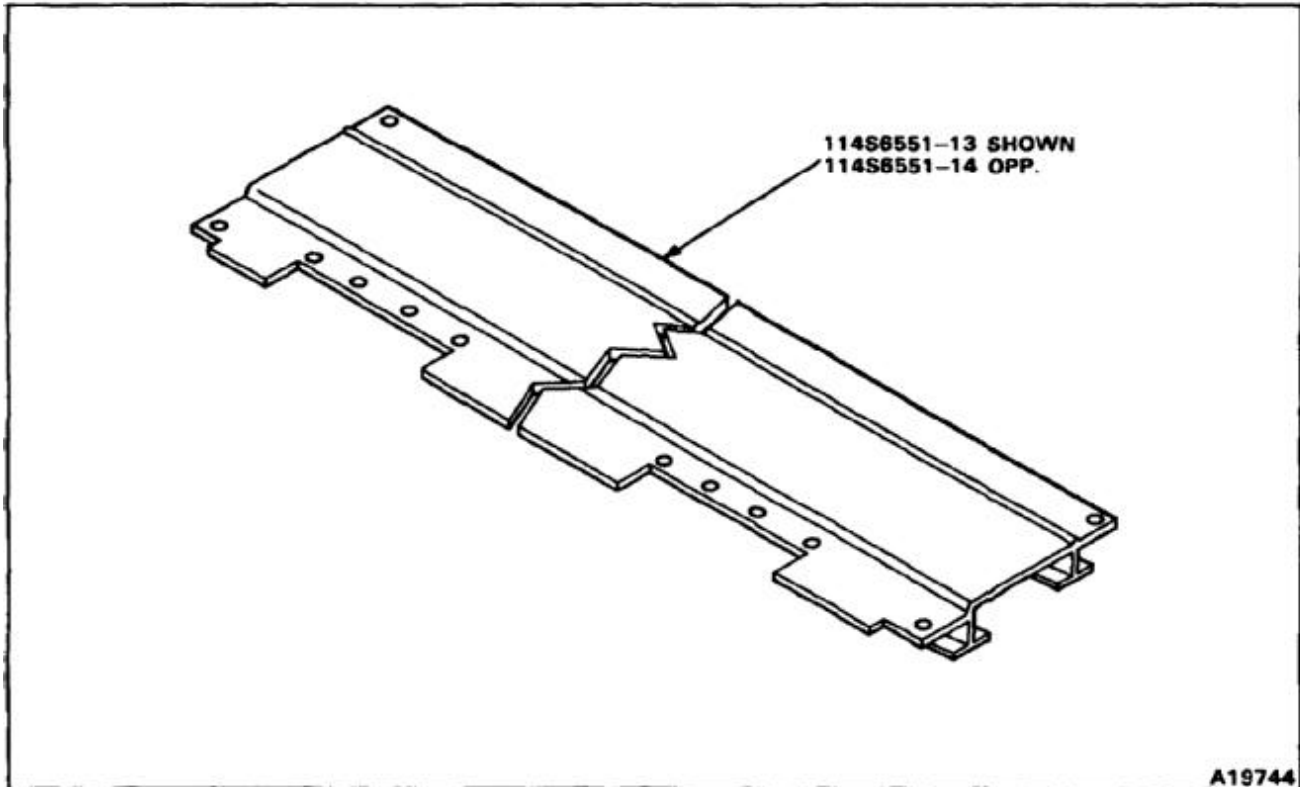

END OF TASK

NOTES:

1. FABRICATE FROM VS90578 MAGNESIUM ALLOY EXTRUSION ZK60A-T5 PER QQ-M-31.
2. STOCK SIZE 91.4 INCHES.
3. USE ORIGINAL PANEL AS TEMPLATE. CUT AND DRILL NEW PANEL TO MATCH.
4. FINISH AS REQUIRED.

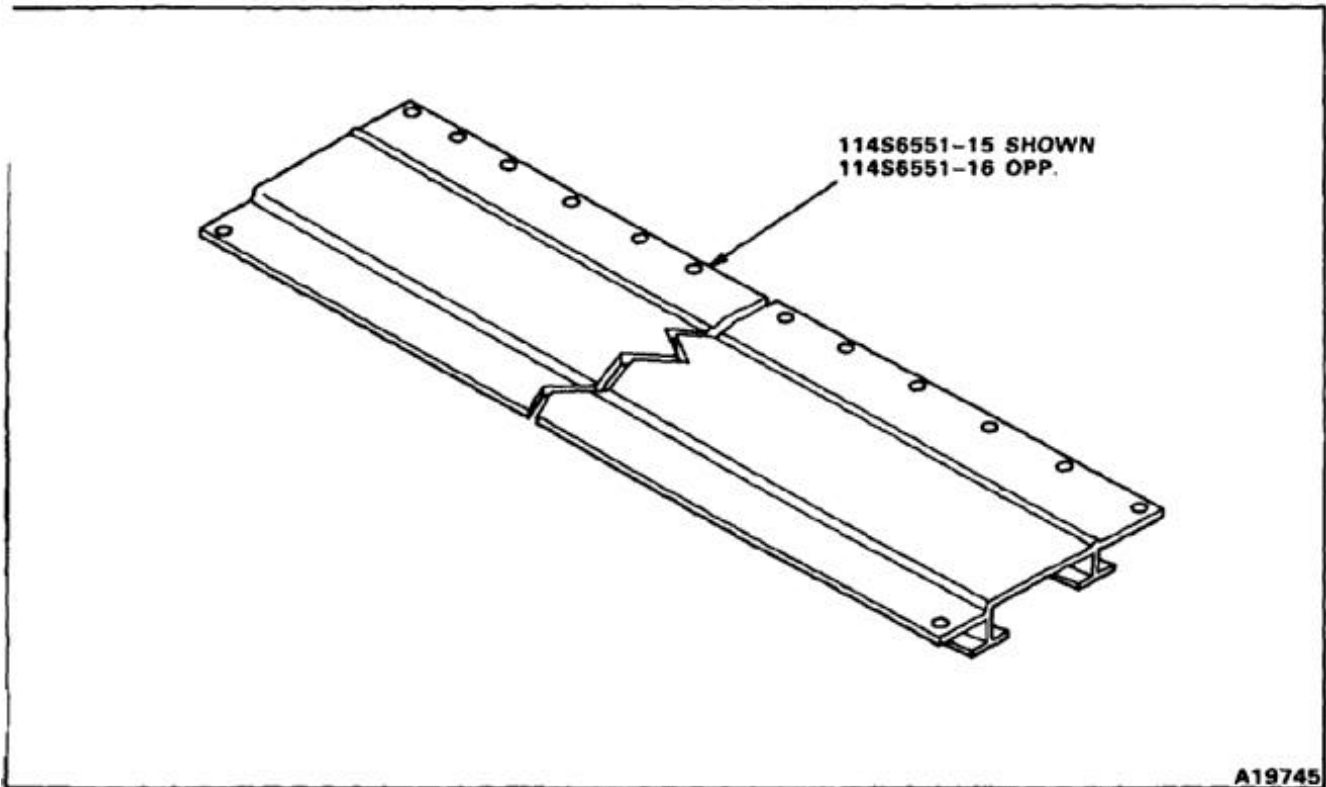

END OF TASK

E-332

NOTES:

1. FABRICATE FROM VS90579 MAGNESIUM ALLOY EXTRUSION ZK60A-T5 PER QQ-M-31.
2. STOCK SIZE 91.4 INCHES.
3. USE ORIGINAL PANEL AS TEMPLATE. CUT AND DRILL NEW PANEL TO MATCH.
4. FINISH AS REQUIRED.

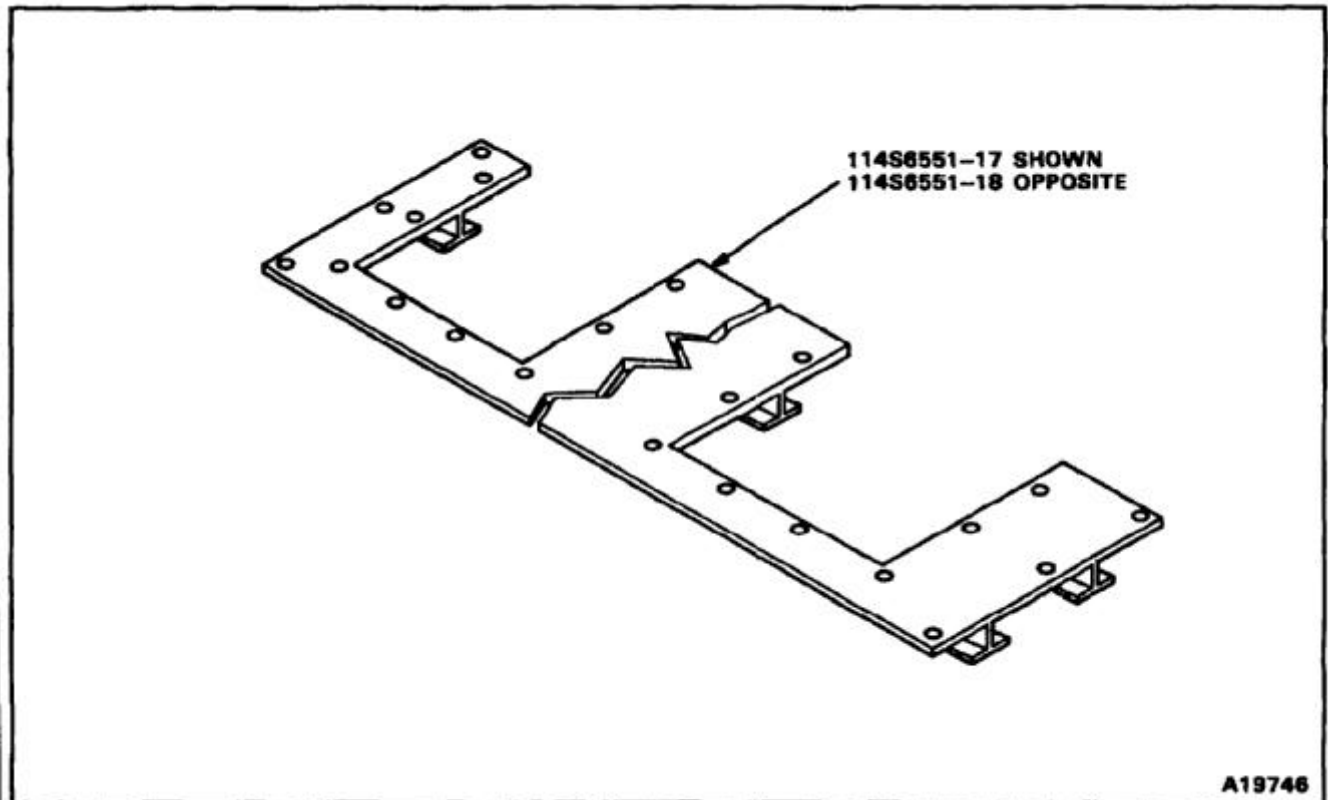

END OF TASK

NOTES:

1. FABRICATE FROM MS20253P5 CADMIUM PLATED CORROSION RESISTANT STEEL.
2. STOCK SIZE 5.0 INCHES.

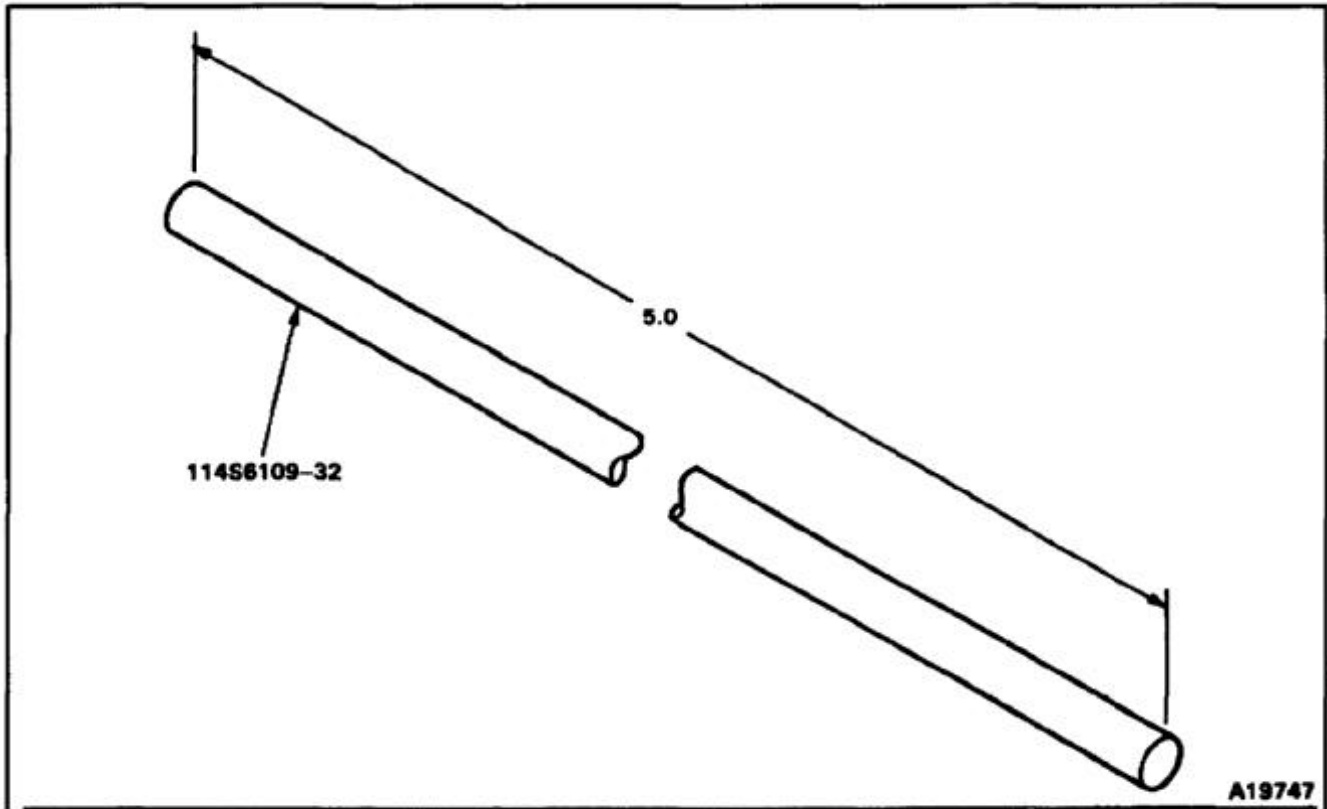

END OF TASK

E-334

NOTES:

1. FABRICATE FROM VELCRO 80 HOOK TAPE, COLOR NO. 320.
2. STOCK SIZE 0.75 X 19.8.
3. ALL DIMENSIONS IN INCHES.

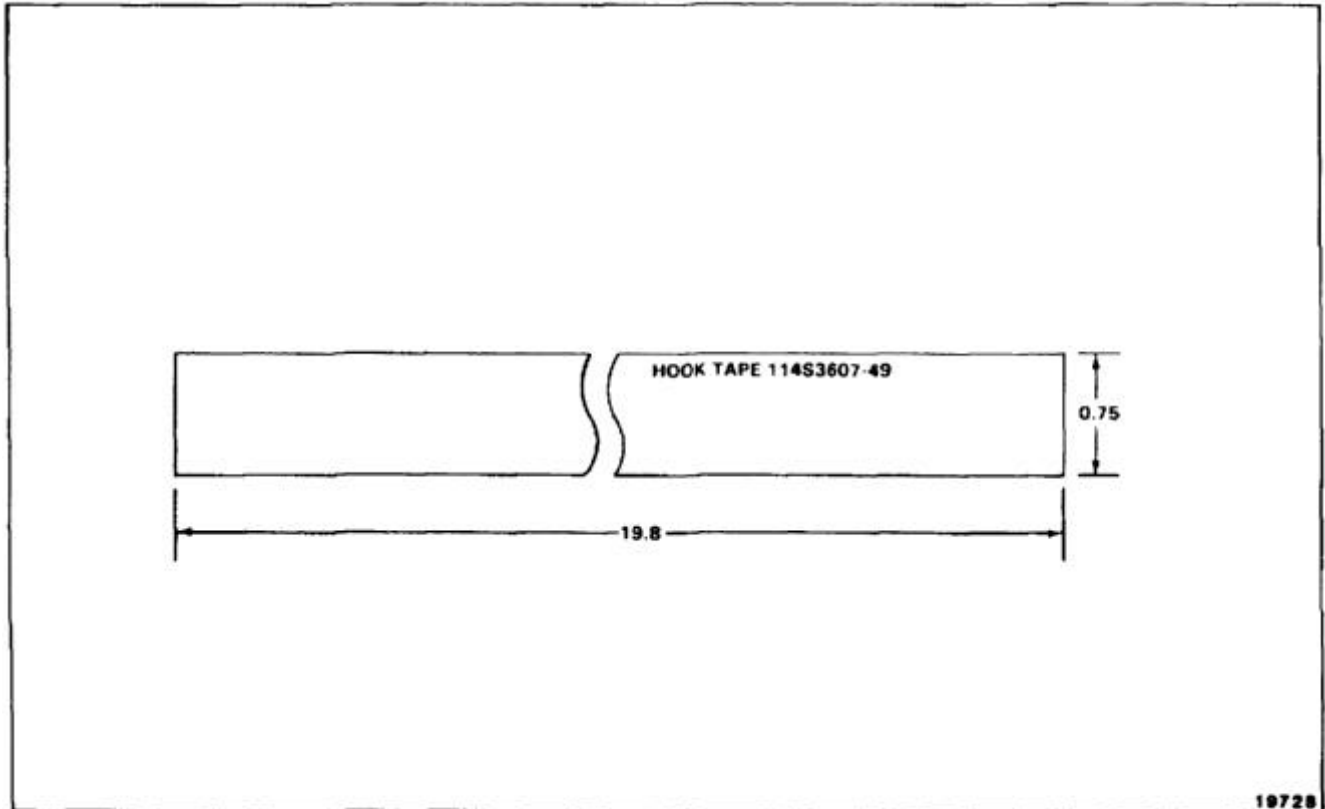

END OF TASK

NOTES:

1. FABRICATE FROM MS20001Y6-5417.
2. USE ORIGINAL PART TO DETERMINE PILOT HOLE LOCATIONS AND X DIMENSION.
3. FINISH AS REQUIRED.

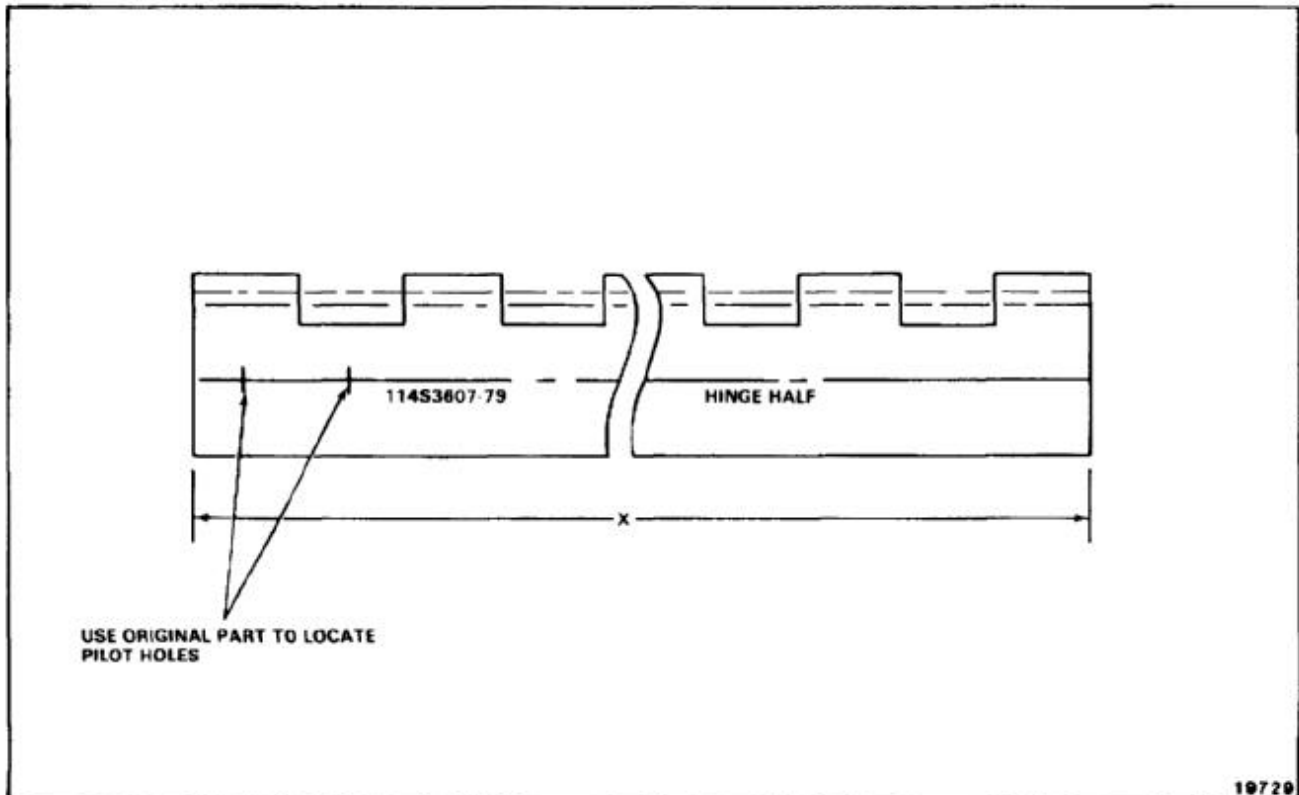

END OF TASK

NOTES:

1. FABRICATE FROM MS20253P2-5417.
2. USE ORIGINAL HINGE PIN TO DETERMINE X DIMENSION.
3. FINISH AS REQUIRED.

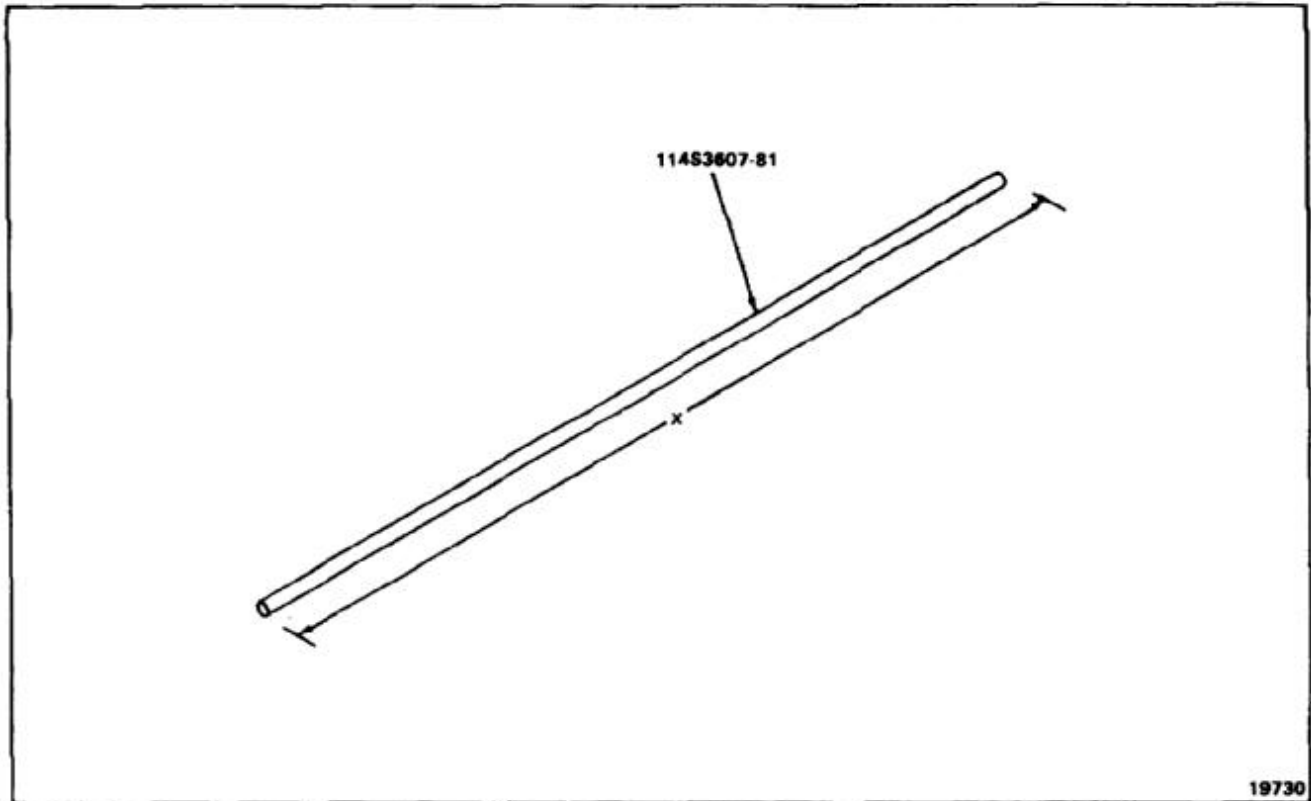

END OF TASK

NOTES:

1. FABRICATE FROM MS20001PX6-5350.
2. USE ORIGINAL HINGE HALF TO DETERMINE PILOT HOLE LOCATIONS AND X DIMENSION.
3. FINISH AS REQUIRED.

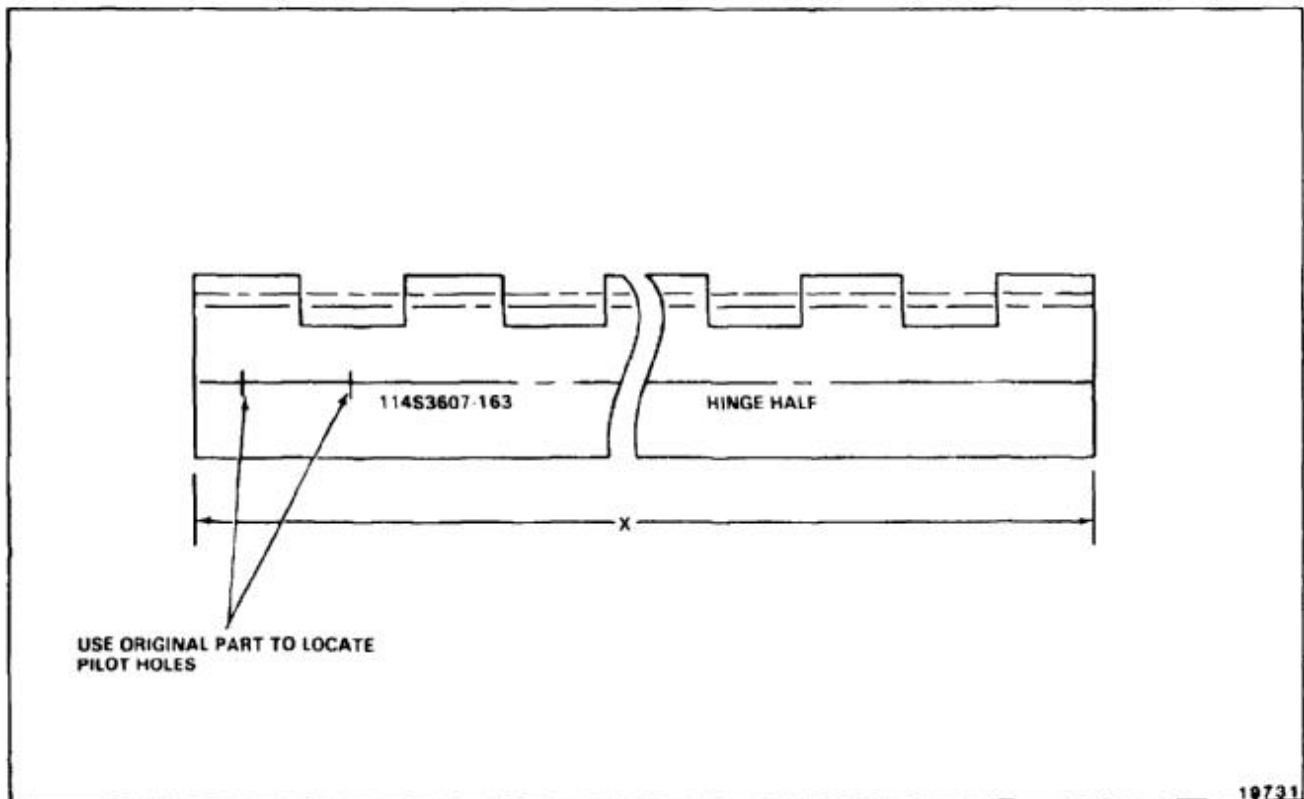

END OF TASK

E-338

NOTES:

1. FABRICATE FROM MS20253P2-5365.
2. USE ORIGINAL HINGE PIN TO DETERMINE X DIMENSION.
3. FINISH AS REQUIRED.

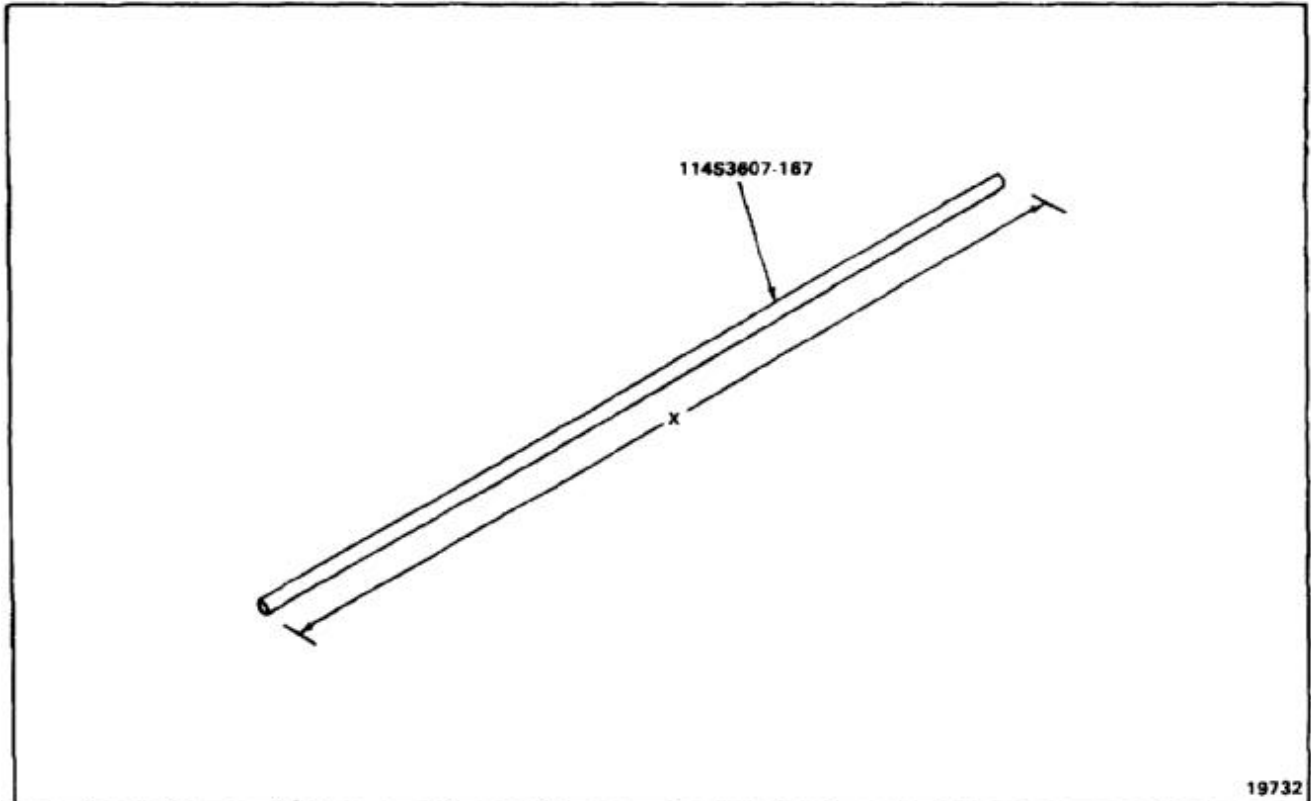

END OF TASK

NOTES:

1. FABRICATE FROM ALUMINUM ALLOY CLAD SHT 2024-T4 PER QQ-A-362.
2. STOCK SIZE -191: 0.025 X 0.60 X 14.1.
STOCK SIZE -195: 0.025 X 0.60 X 61.5.
3. ALL DIMENSIONS IN INCHES.
4. PILOT HOLE LOCATIONS TO BE DETERMINED FROM ORIGINAL PART.
5. FINISH AS REQUIRED.

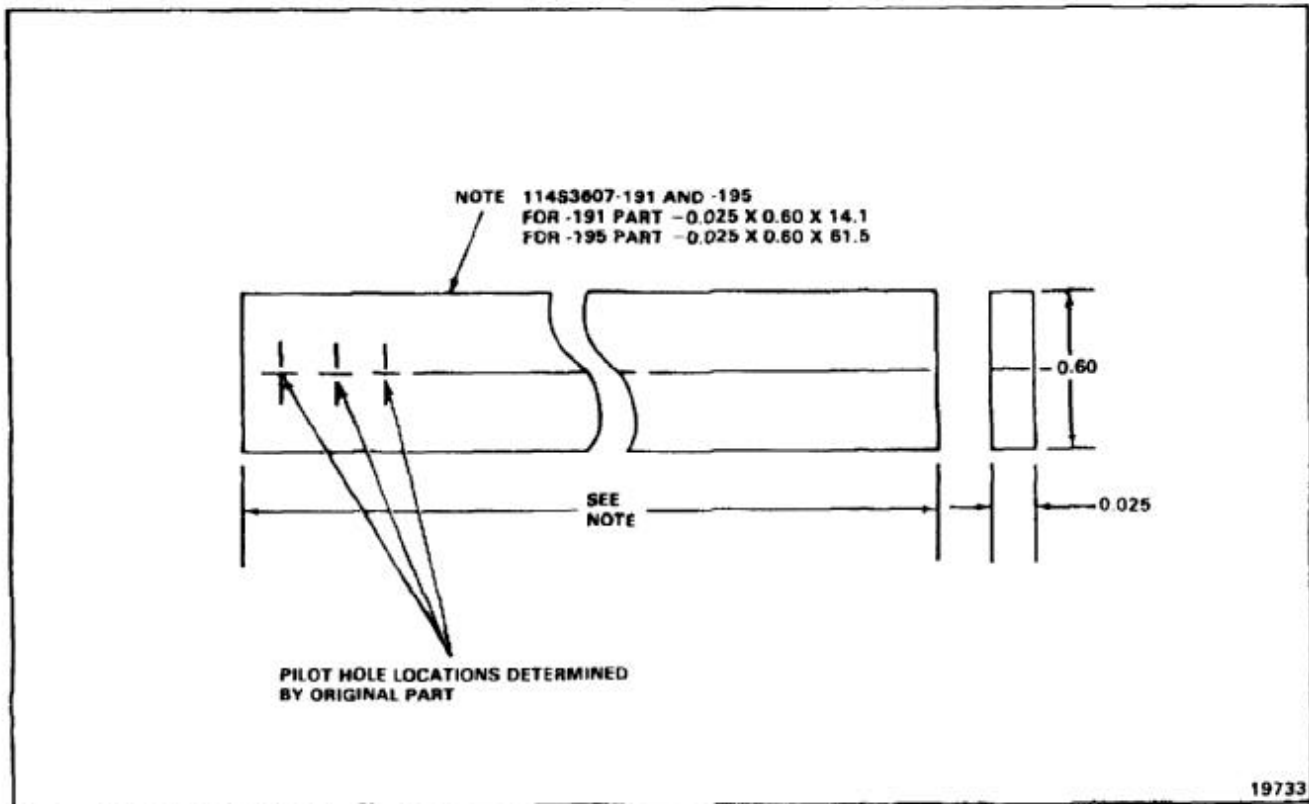

END OF TASK

NOTES:

1. FABRICATE FROM ALUMINUM ALLOY BARE SHEET 7075-T6 PER QQ-A-250/12.
2. STOCK SIZE 0.071 X 2.2 X 18.8.
3. ALL DIMENSIONS IN INCHES.
4. FINISH AS REQUIRED.

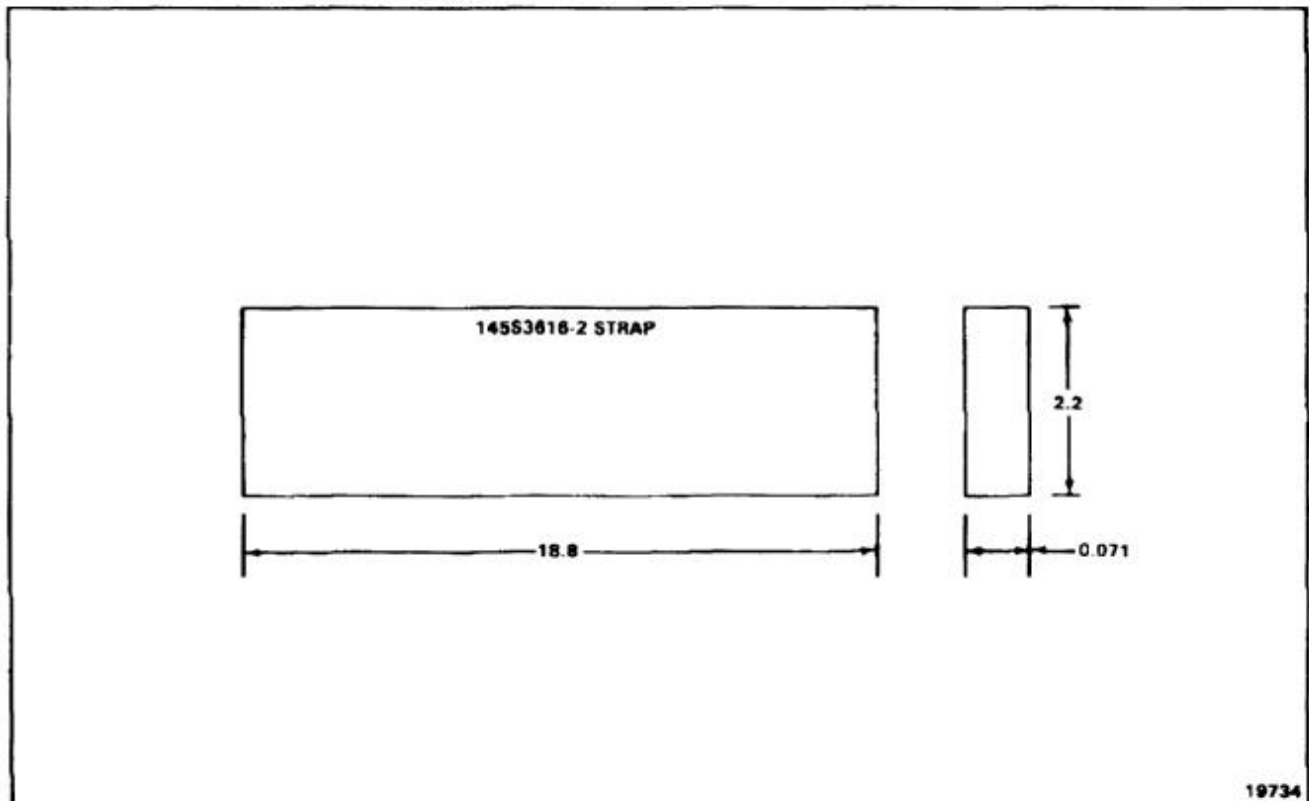

END OF TASK

NOTE:

FABRICATE FROM:

CABINET (SIZE OPTIONAL)	PORTACAB 91F615	TYPE WA-1540	QTY 1
ROTARY SWITCH	PA100 NON-SHORT	22F801	QTY 1
KNOB	P-120	22F646	QTY 1
CONNECTOR	M83723/88Y1624N		QTY 1
CONNECTOR	M83723/95A1624N		QTY 1
LAMP HOLDER	25F1291		QTY 1
PANEL LIGHT	SHORT CYL. 28VDC	25F1434 (RED)	QTY 1
MOMENTARY SWITCH	PUSHBUTTON SPST	23F050	QTY 1
TOGGLE SWITCH	DPST OFF-ON	23F025 (6T2)	QTY 1
JACK	(MUST MATE WITH MULTIMETER TEST LEADS)		QTY 2
	1 RED, 1 BLACK		
WIRE	#22 AWG (STRANDED)		QTY A/R

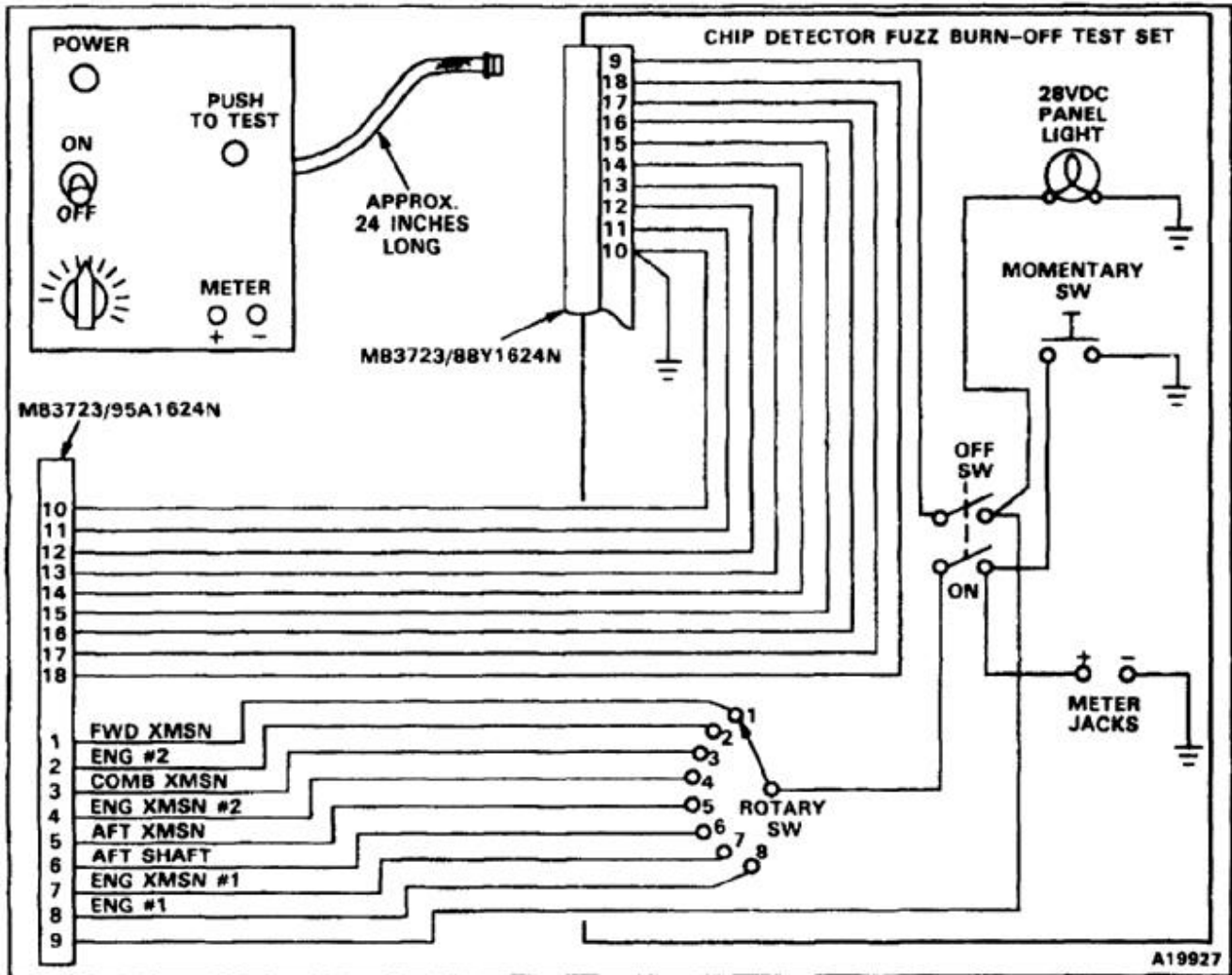

E-267 UPPER CABIN DOOR ESCAPE HATCH RUBBER SEAL 114S1621-5 AND SEAL FILLER 114S1621-7

E-267

NOTES:

1. FABRICATE SEAL FROM VS80570-2 BLACK SEAL, NSN 9390-00-937-2611 OR VS80570-1 GREY SEAL, NSN 9390-00-849-6239.
2. FABRICATE SEAL FILLER FROM VS80569-3 BLACK FILLER, NSN NOT AVAILABLE OR VS80569-2 GREY FILLER, NSN 5330-01-218-3259 OR 33197R FILLER, NSN 9390-00-379-2615.
3. ALL DIMENSIONS IN INCHES.
4. TRIM TO FIT AT INSTALLATION.

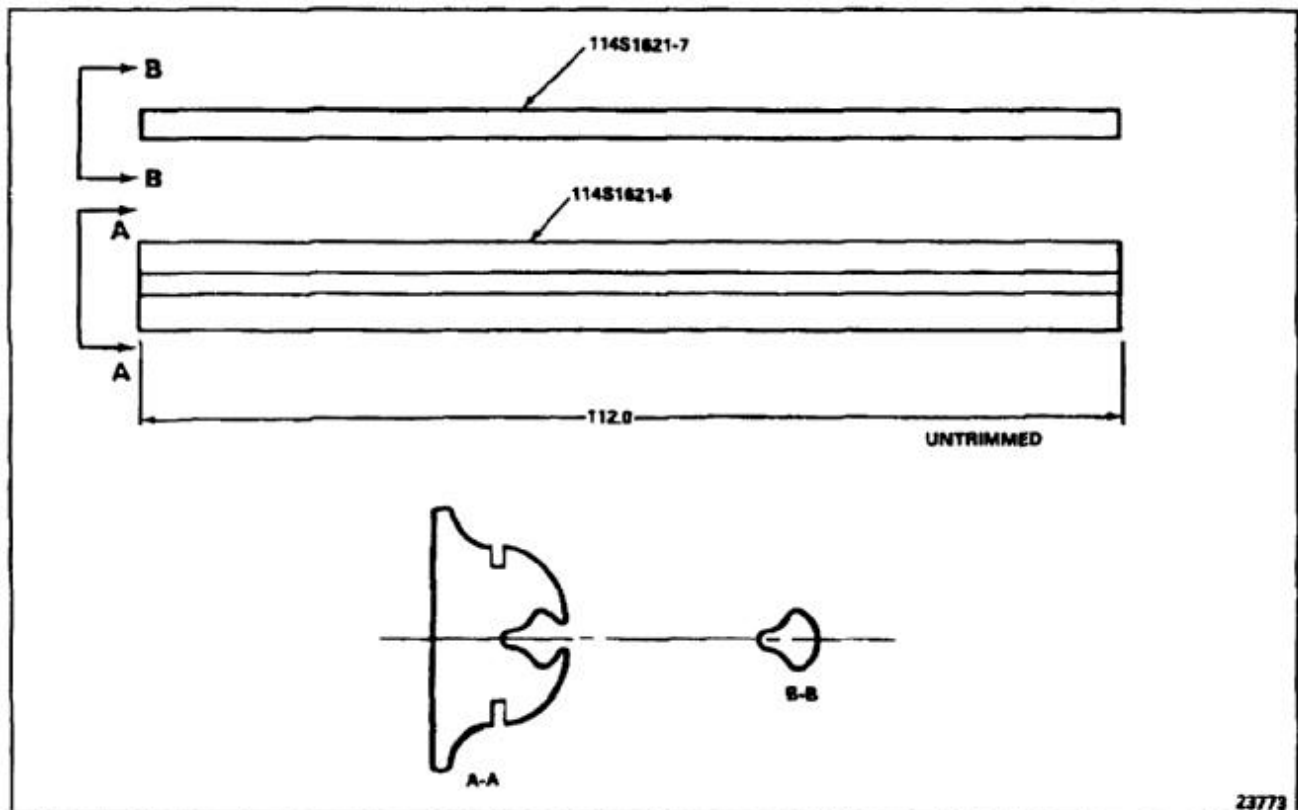

END OF TASK

NOTES:

FABRICATE FROM:

1. STEEL ASTM A36, NSN 9520-00-596-1877
2. CASTER, SWIVEL, S8996R2, NSN 5340-00-489-3491
3. BOLT, HEX HEAD, AN8-11A, NSN 5306-00-208-3646
4. NUT, SELF LOCKING, MS21045-8, NSN 5310-00-062-4954
5. WASHER, AN960-816, NSN 5310-00-332-0813
6. ALL DIMENSIONS IN INCHES,

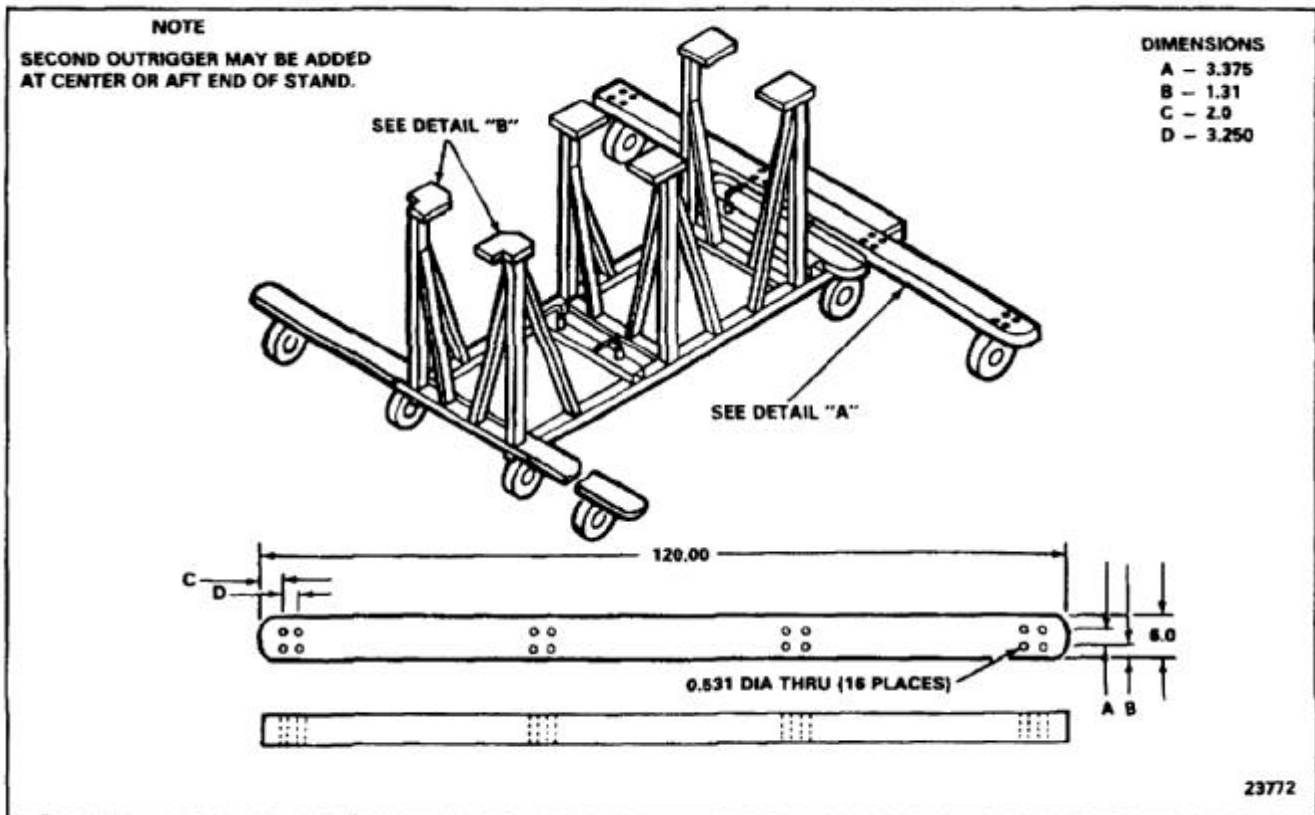

E-268 OUTRIGGER ASSEMBLY 1730CH47-002 FOR VERTICAL PYLON HANDLING SKID
114E5856-22 (Continued)

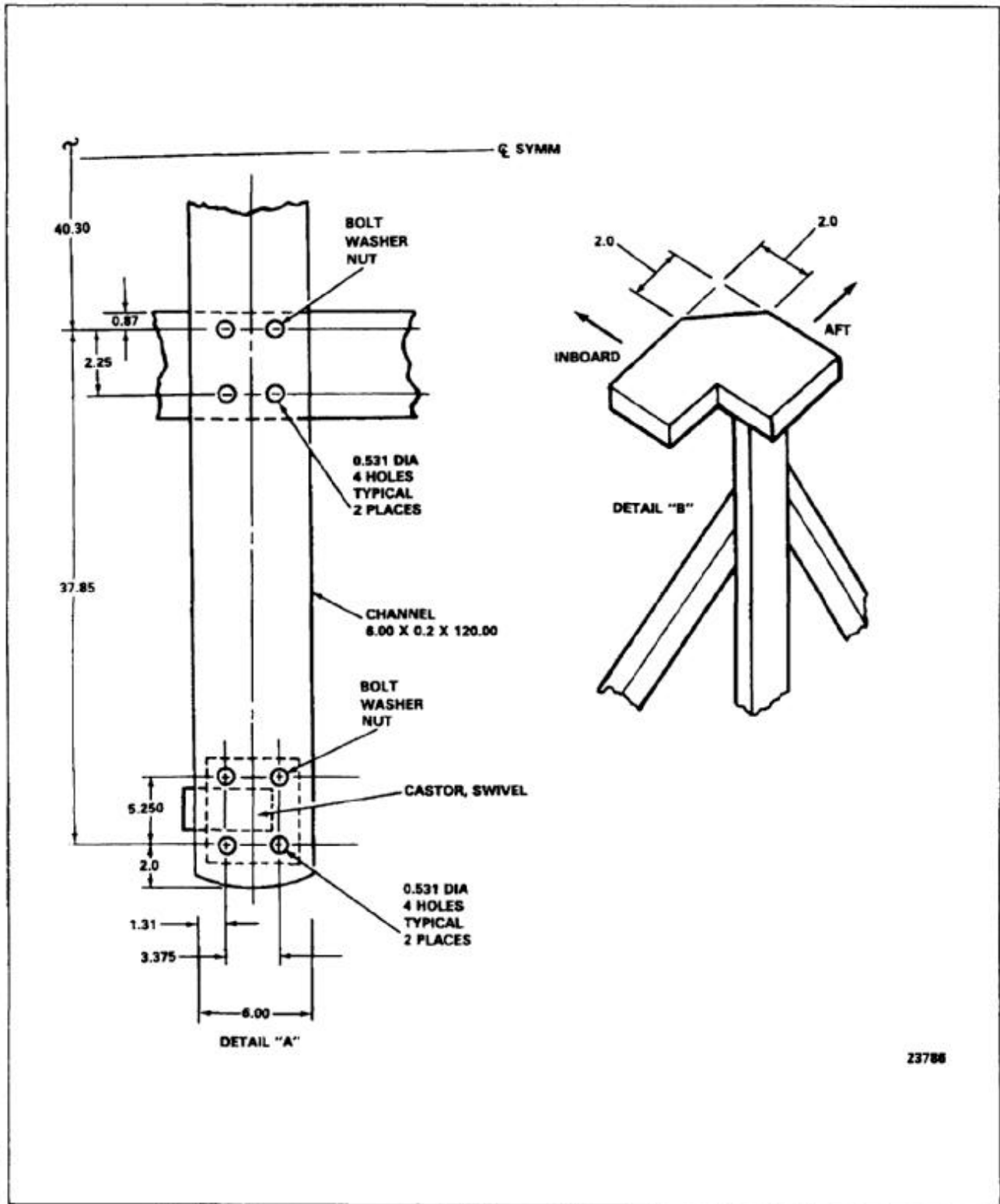

END OF TASK

NOTES:

1. FABRICATE ELECTRICAL LEAD (NO NSN) FROM ALUMINUM STRANDED ALUMINUM WIRE AWG10 AND TERMINALS.
2. STOCK IS:
WIRE, AWG10, NSN 6145-00-926-3344
TERMINAL MS25036-111,
NSN 5940-00-204-8990, HOLE DIAMETER IS 0.142 TO 0.152 AND ACCOMMODATES NUMBER 4 OR 6 STUD.
TERMINAL MS25036-112,
NSN 5940-00-143-4794, HOLE DIAMETER IS 0.193 TO 0.203 AND ACCOMMODATES NUMBER 8 OR 10 STUD.
3. ATTACH TERMINALS (MS25036-111 AND -112) TO WIRE WITH CRIMPING TOOL (MS25441).
4. ALL DIMENSIONS IN INCHES,

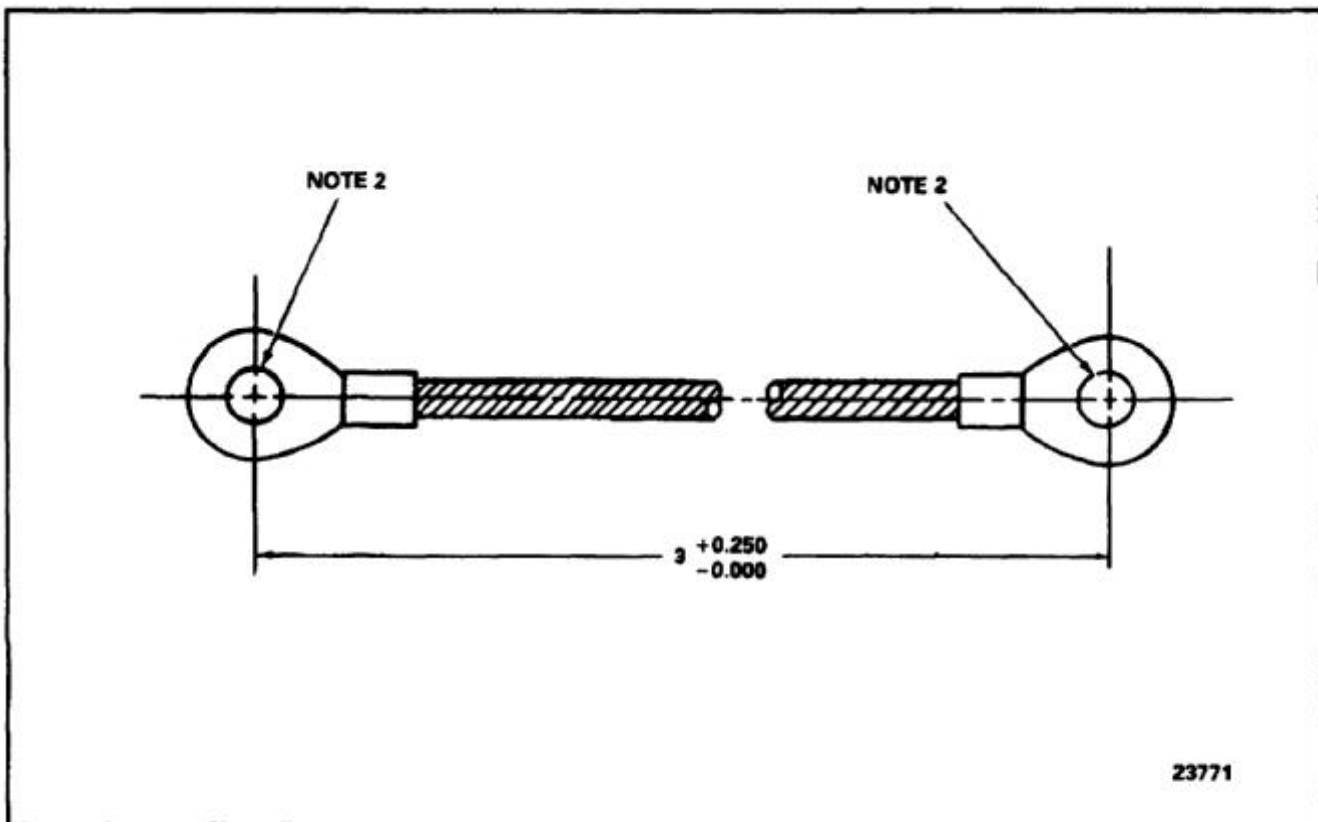

END OF TASK

E-346

NOTES:

1. FABRICATE HINGE ASSEMBLY FROM MS20001-P8.
2. FABRICATE PIN FROM MS20253-2.
3. FINISH AS REQUIRED.
4. ALL DIMENSIONS IN INCHES.

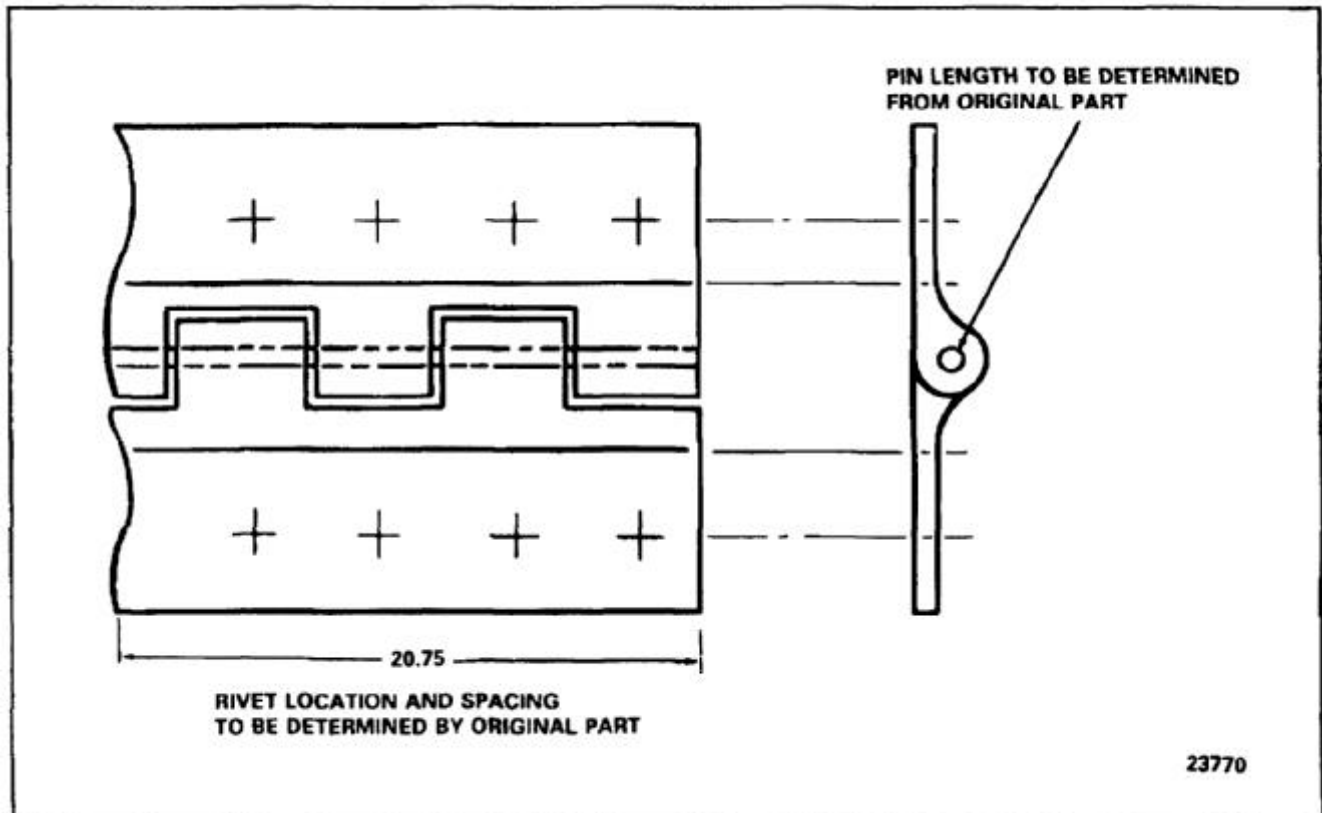

END OF TASK

NOTES:

1. FABRICATE RETAINING STRIPS FROM ALUMINUM ALLOY 2024-T4 CLAD SHEET METAL, NSN 9535-00-167-2278.
2. LENGTH FOR VS25201-030-1935 IS 19.35 INCHES. LENGTH FOR VS25201-030-2560 IS 25.60 INCHES,
3. ALL DIMENSIONS IN INCHES.
4. ±TOLERANCES 0.03 UNLESS OTHERWISE NOTED.
5. MATCH DRILL SEAL RETAINING STRIPS TO EXISTING HOLES. BREAK ALL SHARP EDGES (0.005 MAX).
6. ALODIZE PER MIL-C-5541.
7. APPLY ONE COAT OF ZINC CHROMATE PRIMER, FSM 8010-00-515-2208 PER MIL-P-8585, TB746-93-Z.
8. MARK PART BY INK STAMPING.

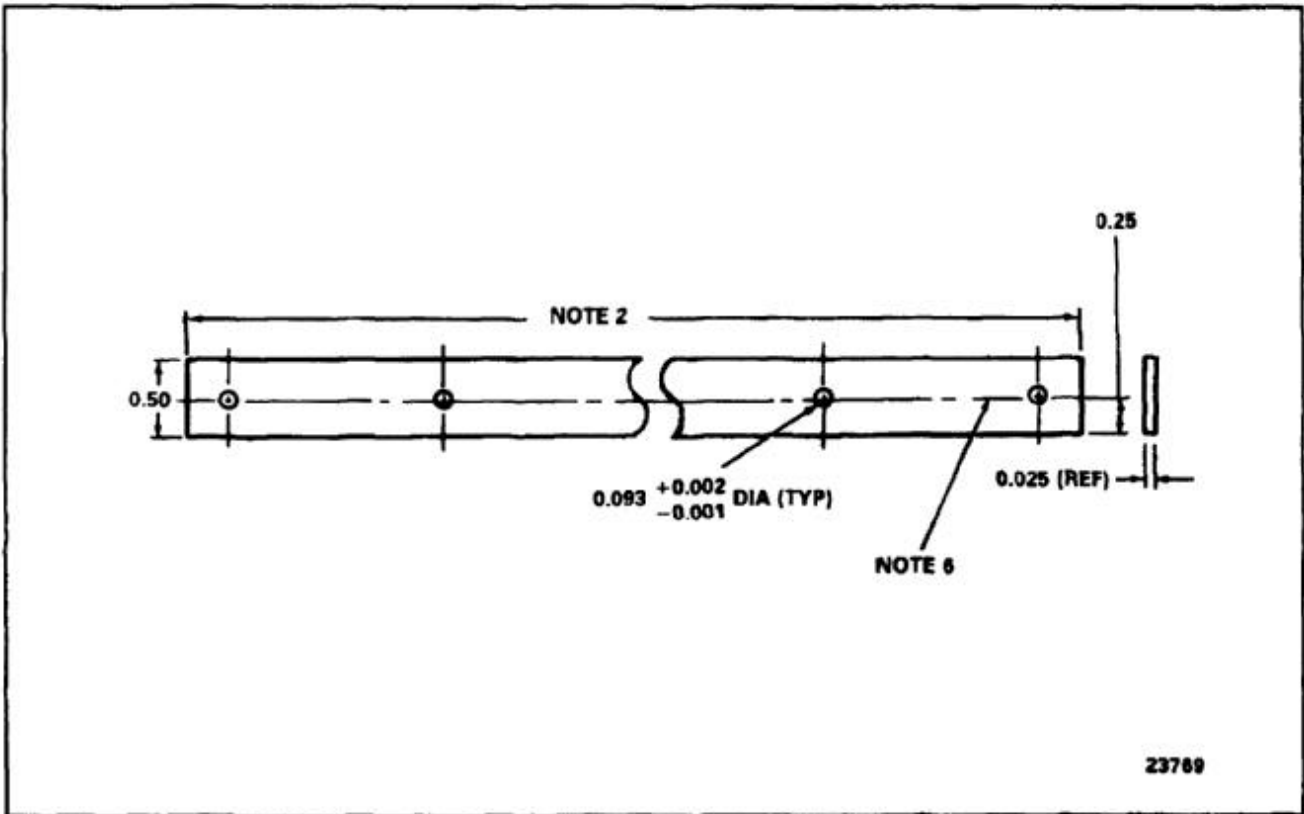

END OF TASK

NOTES:

1. FABRICATE ELECTRICAL LEADS, NSN 6150-00-655-2512 AND NSN 6150-00-807-9802, FROM ALUMINUM STRANDED WIRE SIZE AWG10 AND TERMINALS.
2. WIRE, AWG10, NSN 6145-00-926-3344. TERMINAL, MS25036-112, NSN 5940-00-143-4794. HOLE DIAMETER IS 0.193 TO 0.203 AND ACCOMMODATES NUMBER 8 OR 10 STUD.
3. ATTACH TERMINALS (MS25036-112) TO WIRE WITH CRIMPING TOOL (MS25441).
4. ALL DIMENSIONS IN INCHES.
5. LENGTH FOR MS25083-1BB7 IS
7 +0.250
- 0.000

LENGTH FOR MS25083-1BB10 IS
10 +0.250
- 0.000

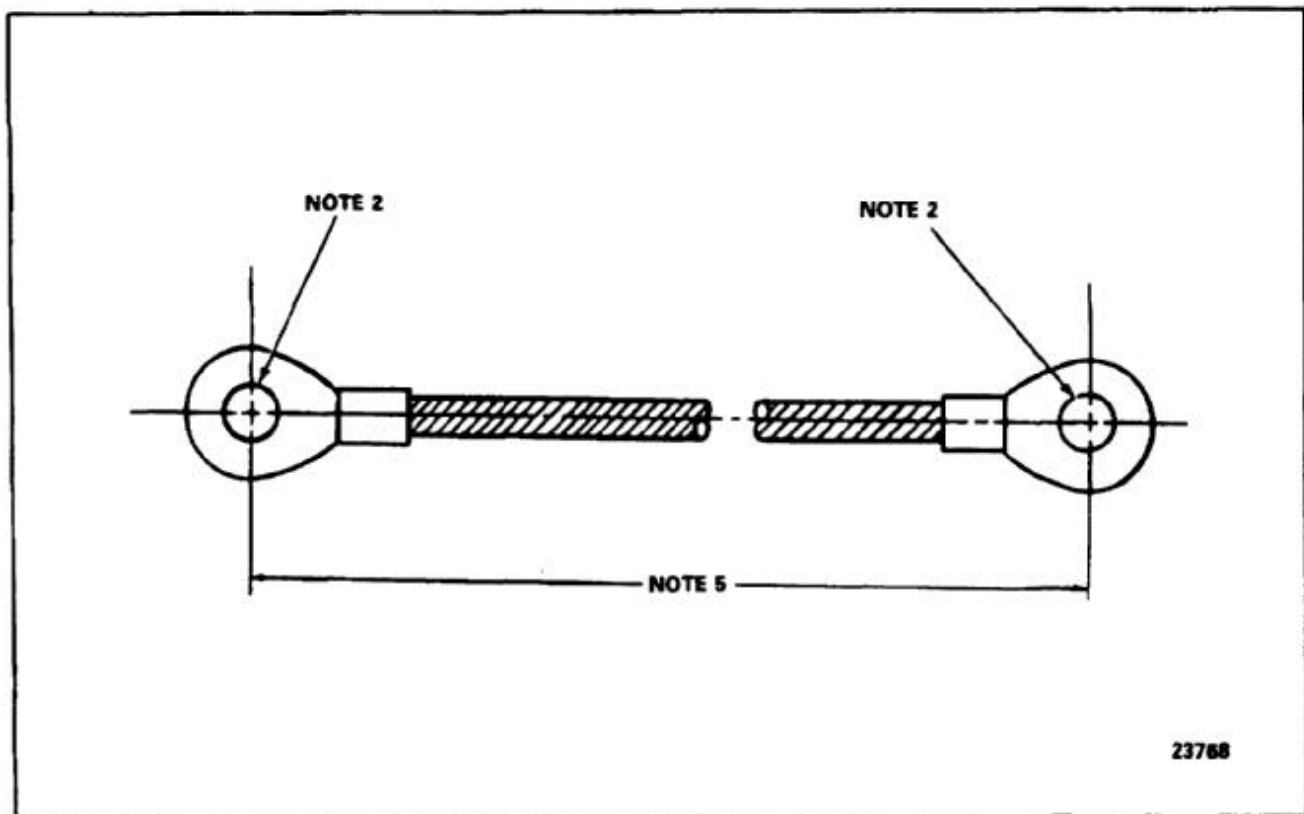

END OF TASK

NOTES:

1. FABRICATE HALF HINGE FROM MS20001H8-940.
2. ALL DIMENSIONS IN INCHES.
3. USE ORIGINAL PART TO DETERMINE PILOT HOLE LOCATIONS AND SHAPE. HALF HINGE MATES WITH HALF HINGE.
4. FINISH AS REQUIRED. ALODINE PER MIL-C-5541. APPLY ONE COAT OF ZINC CHROMATE PRIMER, NSN 8010-00-515-2208, PER MIL-P-8585, TB746-93-2.

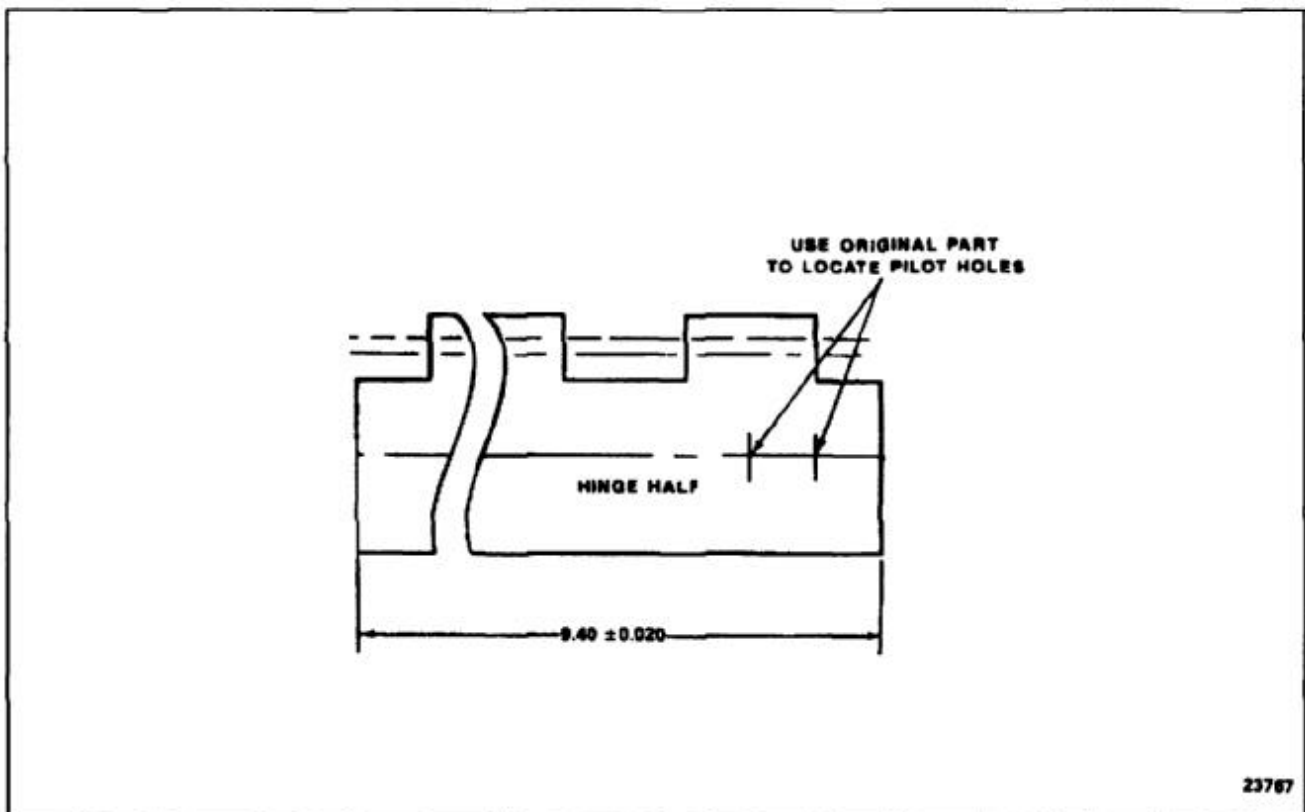

END OF TASK

E-350

NOTES:

1. FABRICATE HINGE PIN FROM MS20253P4,
NSN 5340-00-043-3724.
2. ALL DIMENSIONS IN INCHES.
3. CUT PINS TO LENGTH AND ROUND ENDS.
REMOVE ALL BURRS AND SHARP EDGES.
4. FINISH AS REQUIRED.

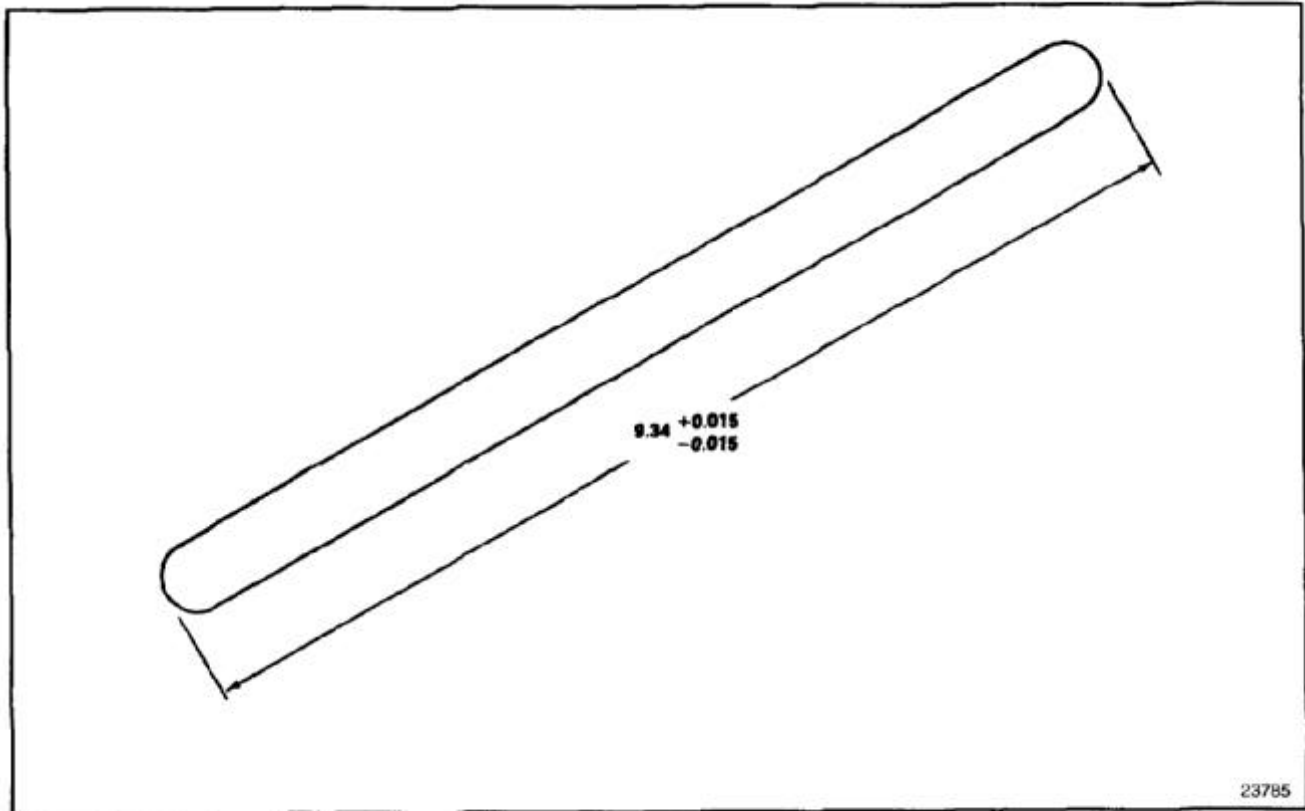

END OF TASK

NOTES:

1. FABRICATE FROM ALUMINUM ALLOY CLAD SHEET 2024-TO PER QQ-A-250/5.
2. STOCK SIZE 0.063 X 2.0 X 105.0.
3. DIMENSIONS ARE IN INCHES.
4. USE ORIGINAL CHANNEL TO DETERMINE DIMENSIONS X, Y, Z AND SHAPE. SOLUTION HEAT TREAT TO T42 PER MIL-H-6088 AFTER FORMING.
5. FINISH AS REQUIRED.

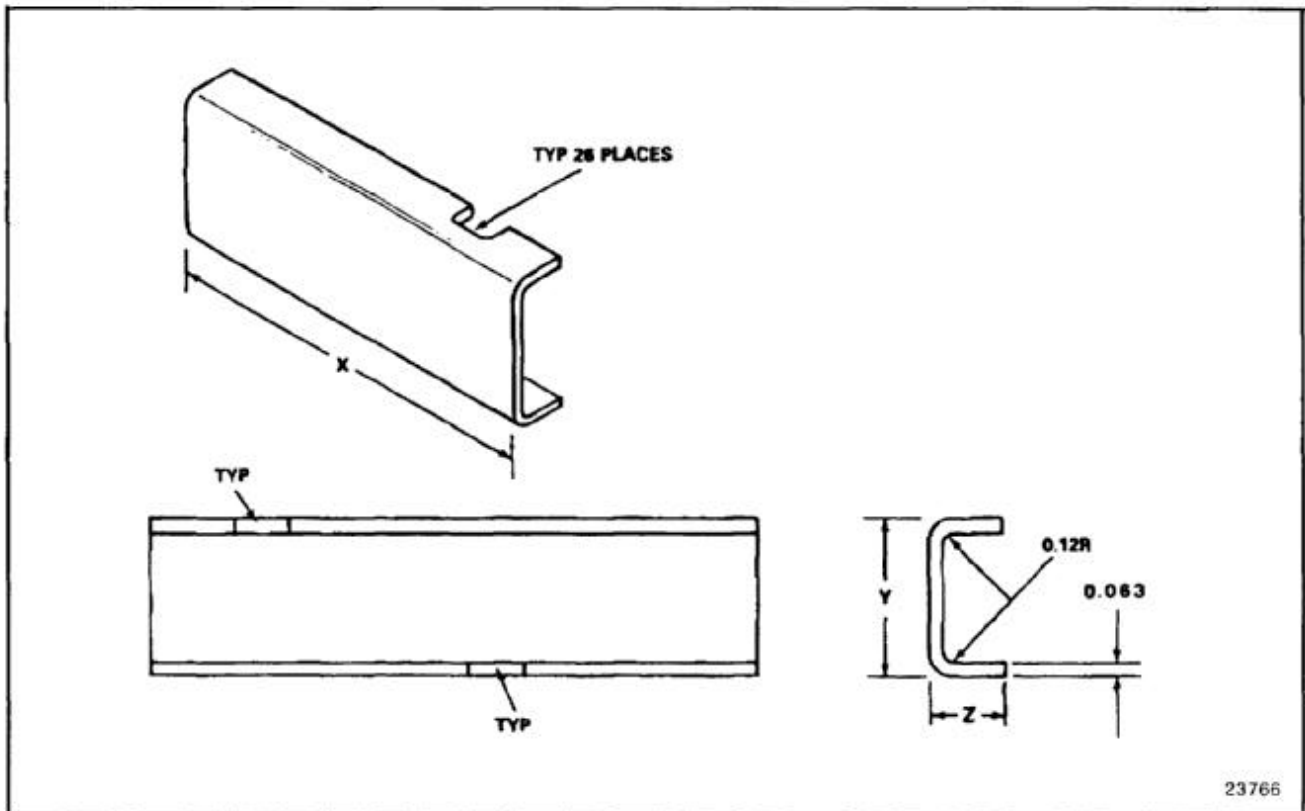

END OF TASK

E-352

NOTES:

1. FABRICATE ELECTRICAL LEAD (NO NSN) FROM STRANDED ALUMINUM WIRE SIZE AWG10 AND TERMINALS.
2. WIRE, AWG10, (NSN 6145-00-926-3344) TERMINAL, MS25036-112, (NSN 5904-00-204-8990), HOLE DIAMETER IS 0.142 TO 0.152 AND ACCOMMODATES NUMBER 8 OR 10 STUD. TERMINAL, MS25036-152 (NSN 5940-00-143-4777), HOLE DIAMETER IS 0.250 TO 0.285 AND ACCOMMODATES 0.250 STUD.
3. ATTACH TERMINALS (MS25036-112 AND 157) TO WIRE WITH CRIMPING TOOL (MS25441).
4. ALL DIMENSIONS IN INCHES.

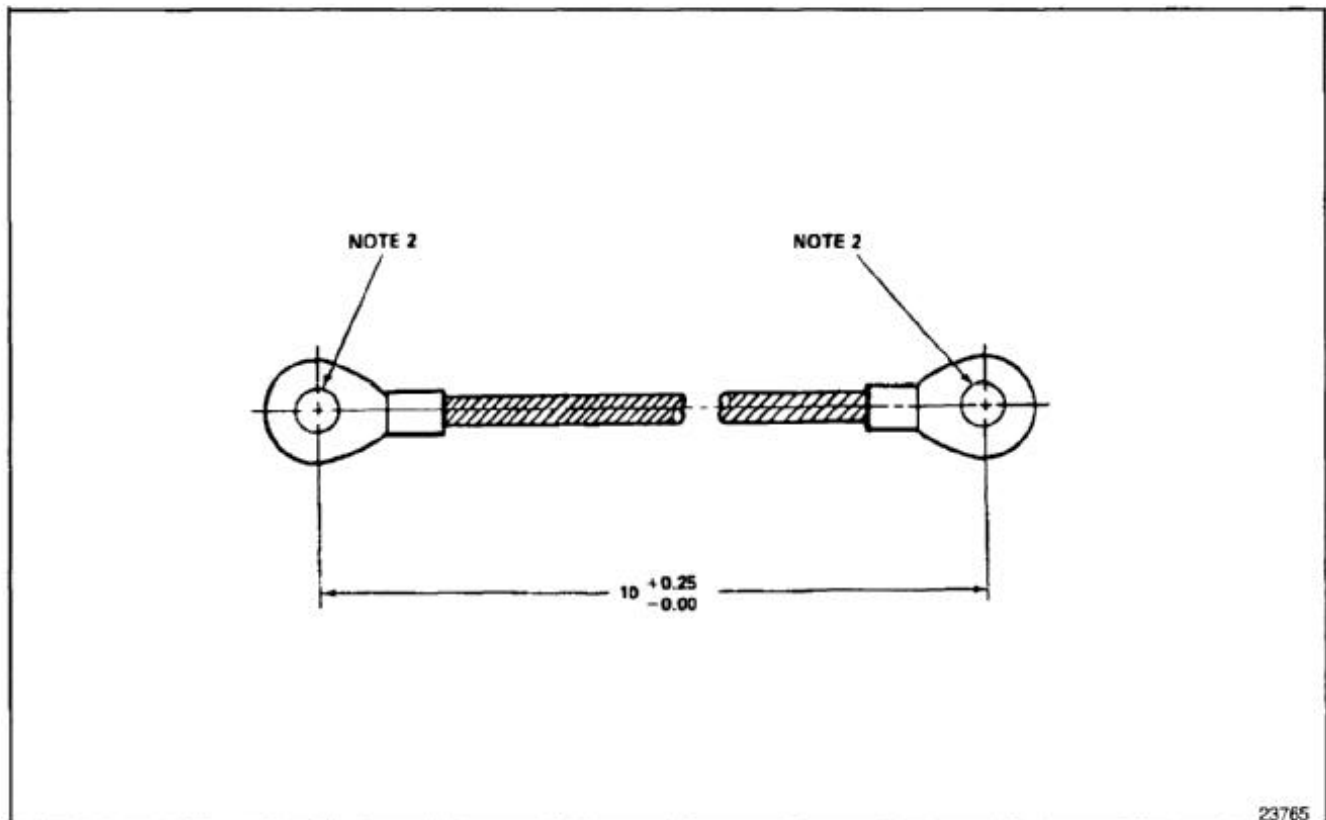

23765

END OF TASK

NOTES:

1. FABRICATE FROM ALUMINUM ALLOY CLAD SHEET 2024-T3 PER QQ-A-250/5.
2. ALL DIMENSIONS IN INCHES.
3. FINISH AS REQUIRED.
4. STOCK SIZE:
X = 2.9
Y = 1.7
5. USE ORIGINAL PART TO DETERMINE DIMENSIONS X AND Y.

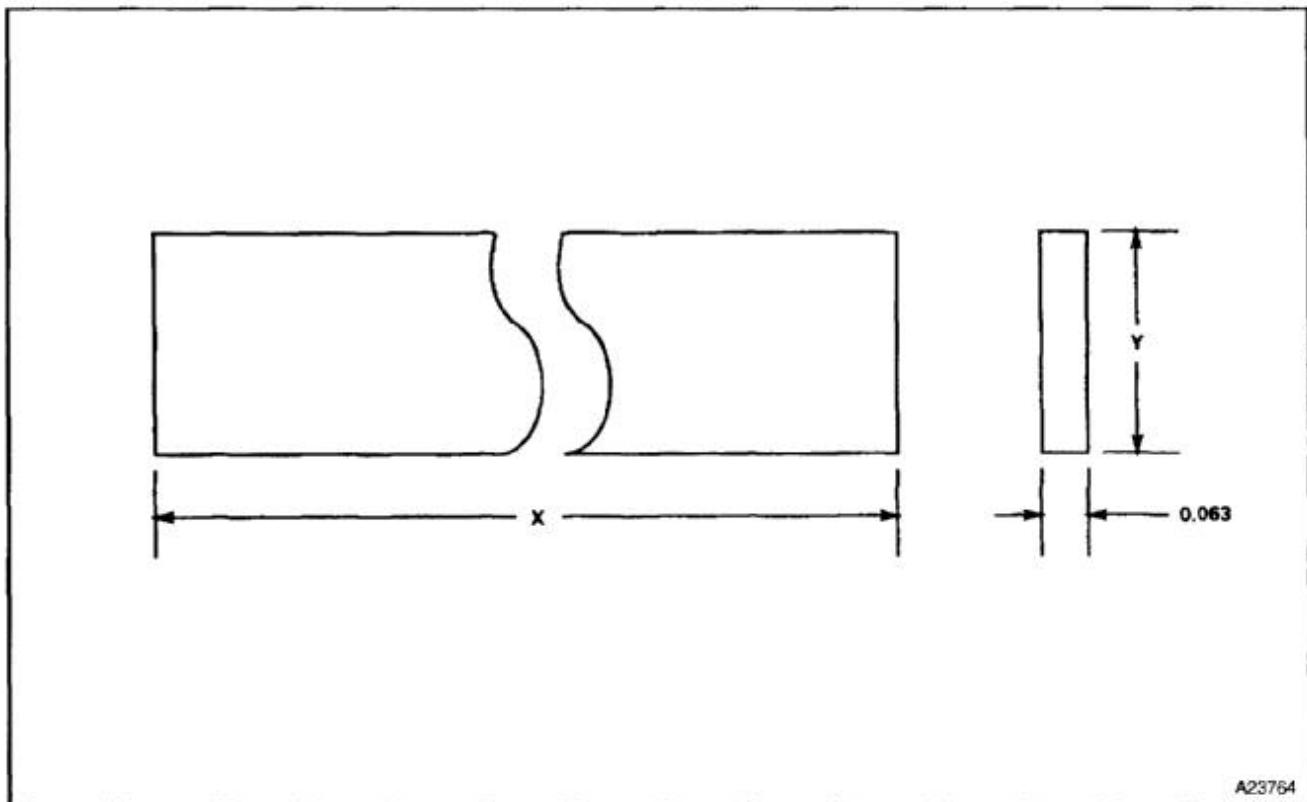

END OF TASK

E-354

NOTES:

1. FABRICATE FROM LAMINATED PHENOLIC TYPE FBM PER MIL-P-15035.
2. ALL DIMENSIONS IN INCHES.
3. FINISH AS REQUIRED.

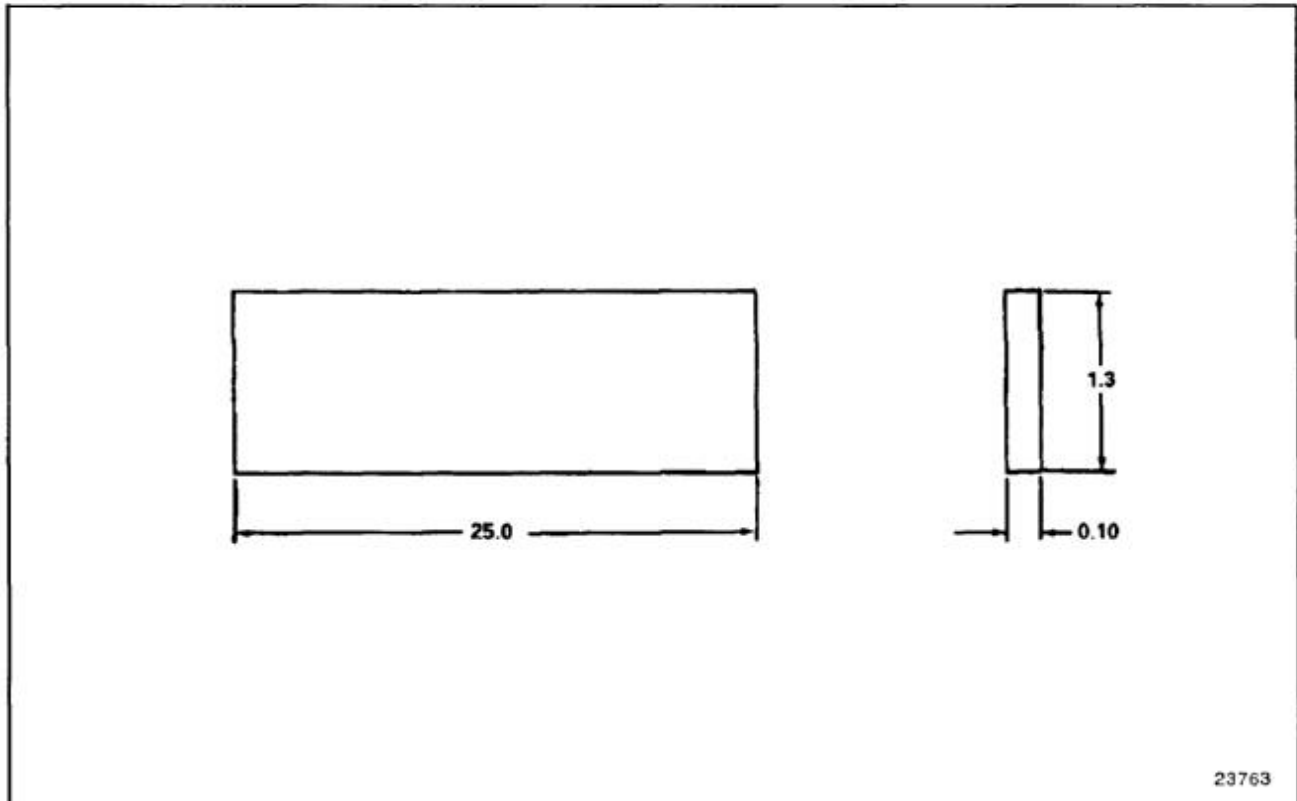

END OF TASK

NOTES:

1. FABRICATE FROM SILICONE SPONGE RUBBER CLOSED CELL SHEET, (MEDIUM) AMS 3195.
2. ALL DIMENSIONS IN INCHES.

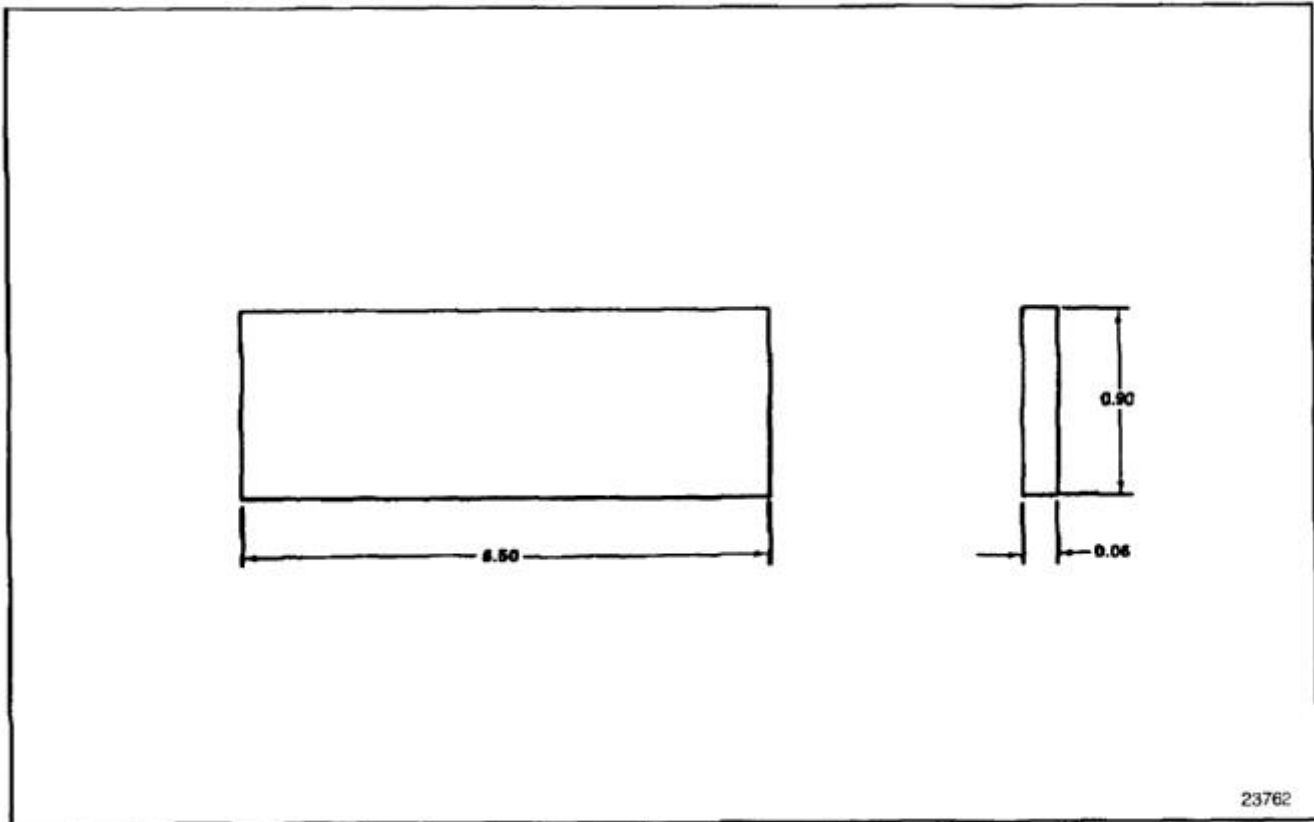

END OF TASK

E-356

NOTES:

1. FABRICATE FROM AMS 3326 SILICONE RUBBER BAC 1530-48, NSN 9390-00-945-4826.
2. ALL DIMENSIONS IN INCHES.
3. STOCK SIZE 80.000
4. LENGTH:
114S3607-181 = 14.100
114S3607-187 = 61.500

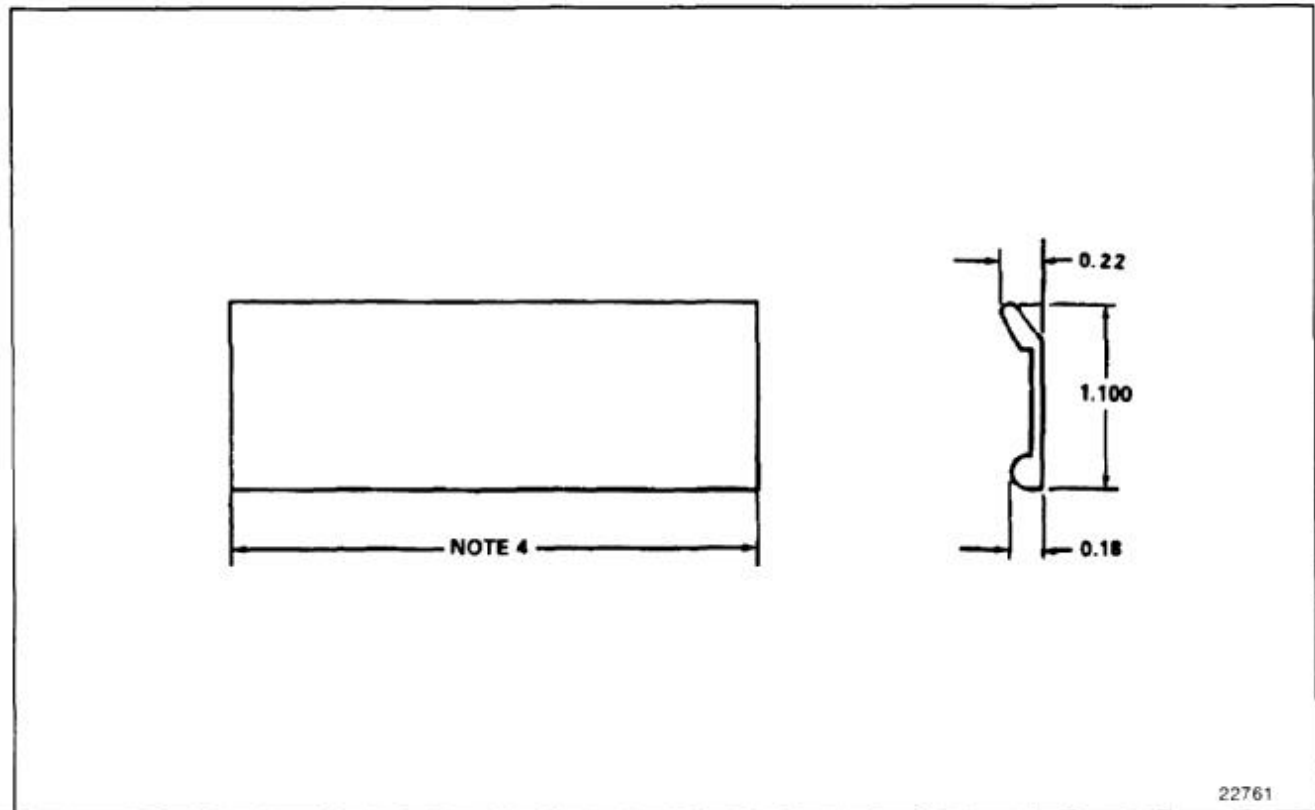

22761

END OF TASK

NOTES:

1. FABRICATE FROM VS80574 NYLATRON GS. THE POLYMER CORP. OF PA, READING, PA. 19603 (CAGE NO. 83616) OR NYLON PER MIL-P-46060 COLOR LIGHT TO DARK GREY.
2. ALL DIMENSIONS IN INCHES.
3. TOLERANCES: 0.02, 0.010 UNLESS OTHERWISE SPECIFIED.
4. LATERAL HOLE LOCATION USE OLD BEARING PAD OR TRANSFER DRILL FROM AIRFRAME TO PAD.
5. STOCK SIZE VS80574 X 7.10.
6. TRIM AS NECESSARY TO FIT.

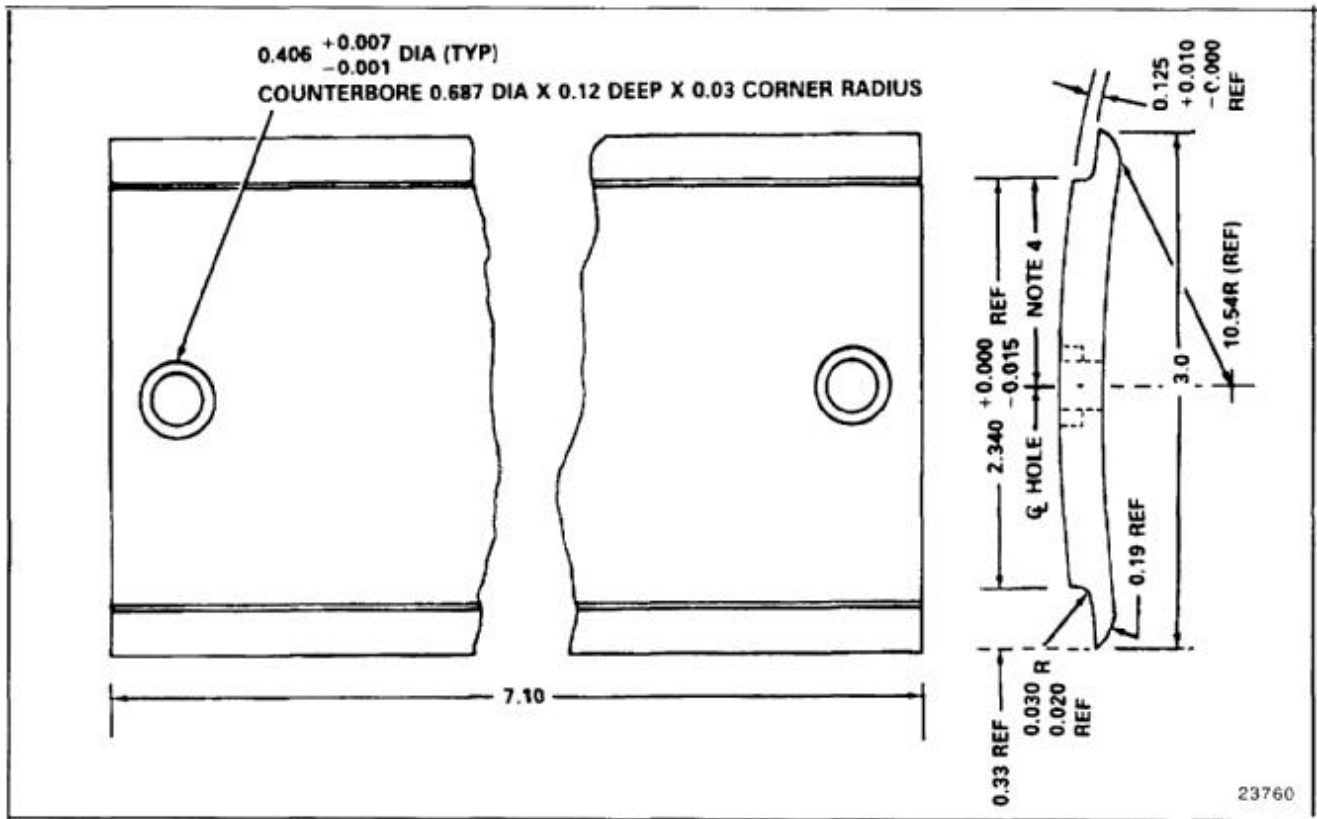

END OF TASK

NOTES:

1. FABRICATE FROM BAC 1530-43,
NSN 9390-00-791-7789.
2. ALL DIMENSIONS IN INCHES.
3. LENGTH:
114S6002-182 = 105.00
114S6002-183 = 53.00
114S6002-184 = 53.00

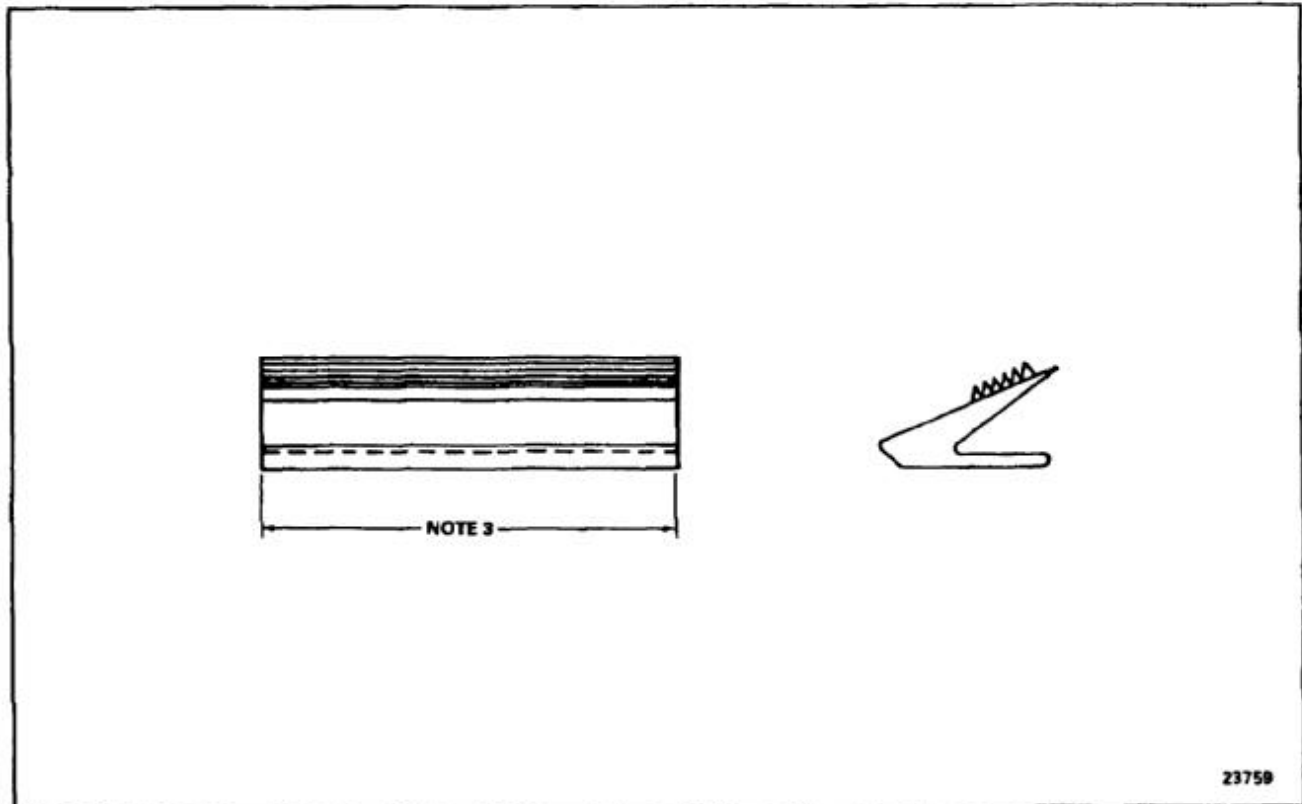

END OF TASK

NOTES:

1. FABRICATE FROM BAC 1530-7,
NSN 9390-00-792-1501.
2. ALL DIMENSIONS IN INCHES.

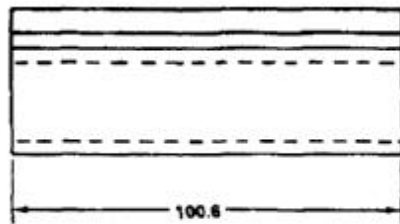

23758

END OF TASK

E-360

NOTES:

1. FABRICATE FROM MS20253P2-188,
NSN 5315-00-091-3429.
2. ALL DIMENSIONS IN INCHES.
3. CUT PINS TO LENGTH AND ROUND ENDS.
REMOVE ALL BURRS AND SHARP EDGES.
4. FINISH AS REQUIRED.

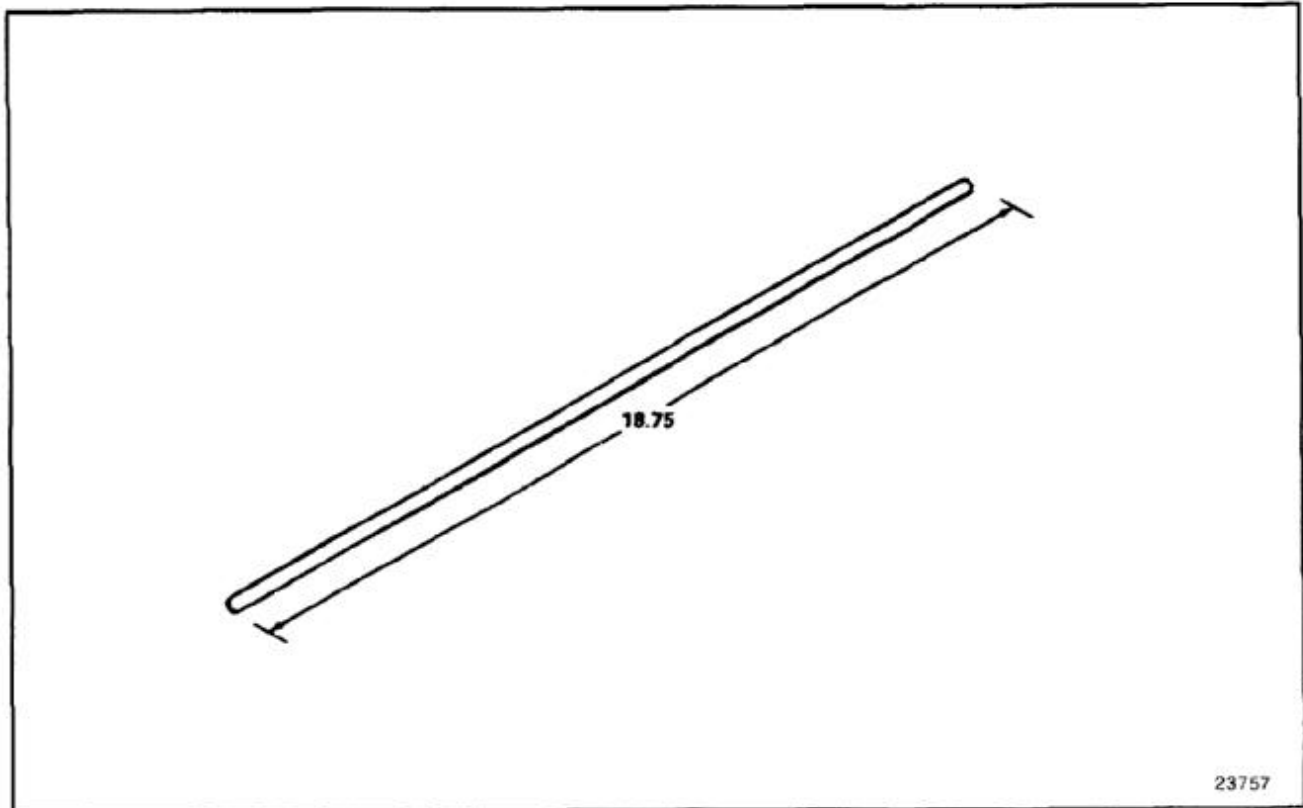

END OF TASK

NOTES:

1. FABRICATE FROM MS20001Y12-800.
2. ALL DIMENSIONS IN INCHES.
3. USE ORIGINAL PART TO DETERMINE PILOT HOLE LOCATIONS AND SHAPE.
4. FINISH AS REQUIRED.

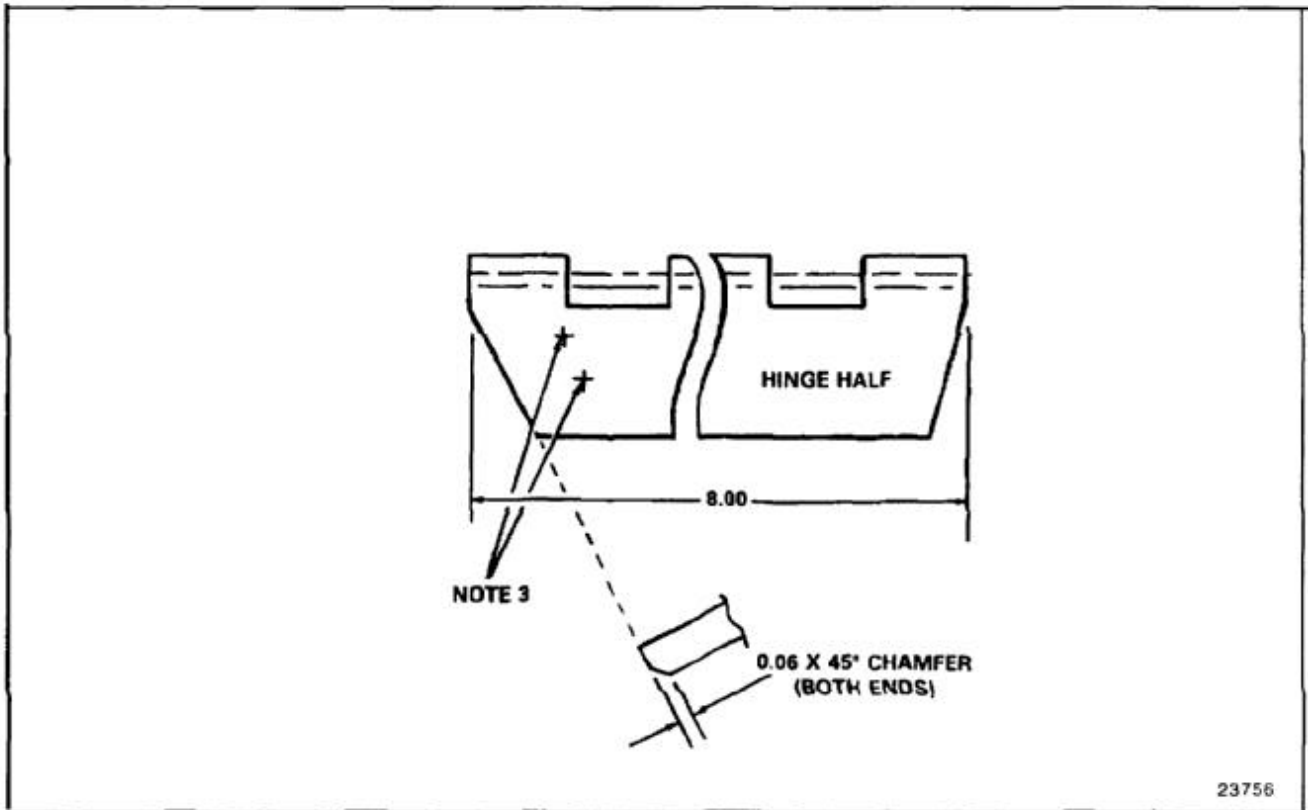

END OF TASK

E-362

NOTES:

1. FABRICATE FROM MS20001X12-190.
2. ALL DIMENSIONS IN INCHES.
3. USE ORIGINAL PART TO DETERMINE PILOT HOLE LOCATIONS AND SHAPE.
4. FINISH AS REQUIRED.

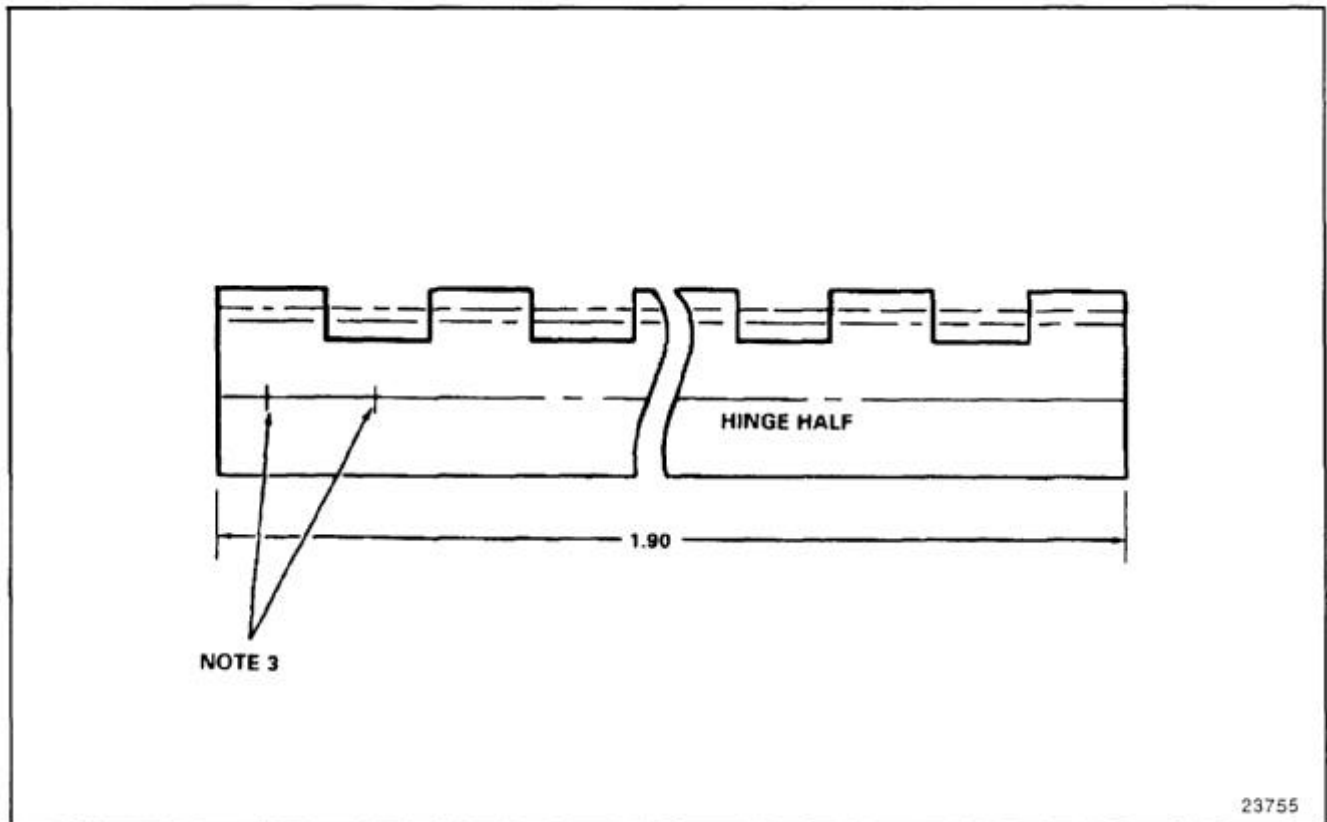

23755

END OF TASK

NOTES:

1. FABRICATE FROM MS20001X14-230.
2. ALL DIMENSIONS IN INCHES.
3. USE ORIGINAL PART TO DETERMINE PILOT HOLE LOCATIONS AND SHAPE.
4. FINISH AS REQUIRED.

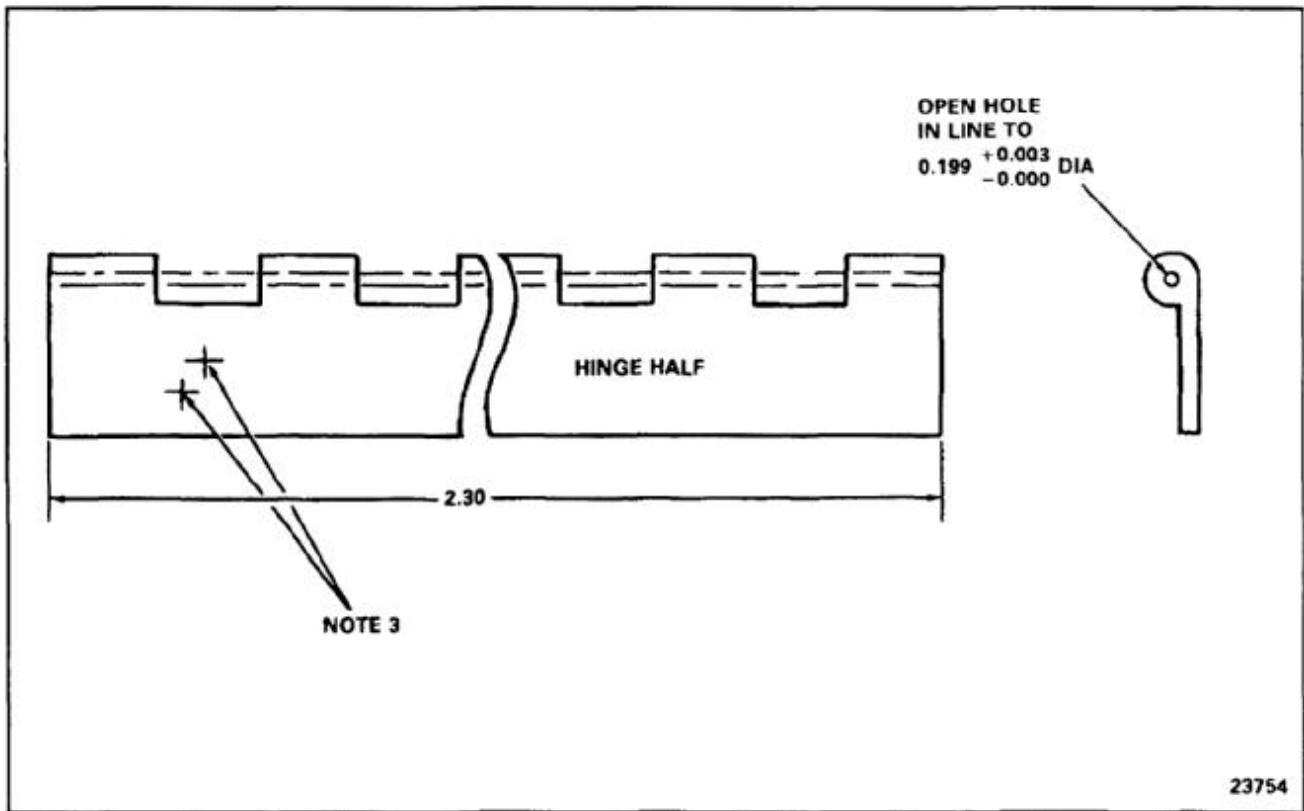

END OF TASK

NOTES:

1. FABRICATE FROM AND 10137-1405,
NSN 9540-00-234-0588.
2. ALL DIMENSIONS IN INCHES.
3. USE ORIGINAL PART TO DETERMINE PILOT
HOLE LOCATIONS AND SHAPE.
4. FINISH AS REQUIRED.

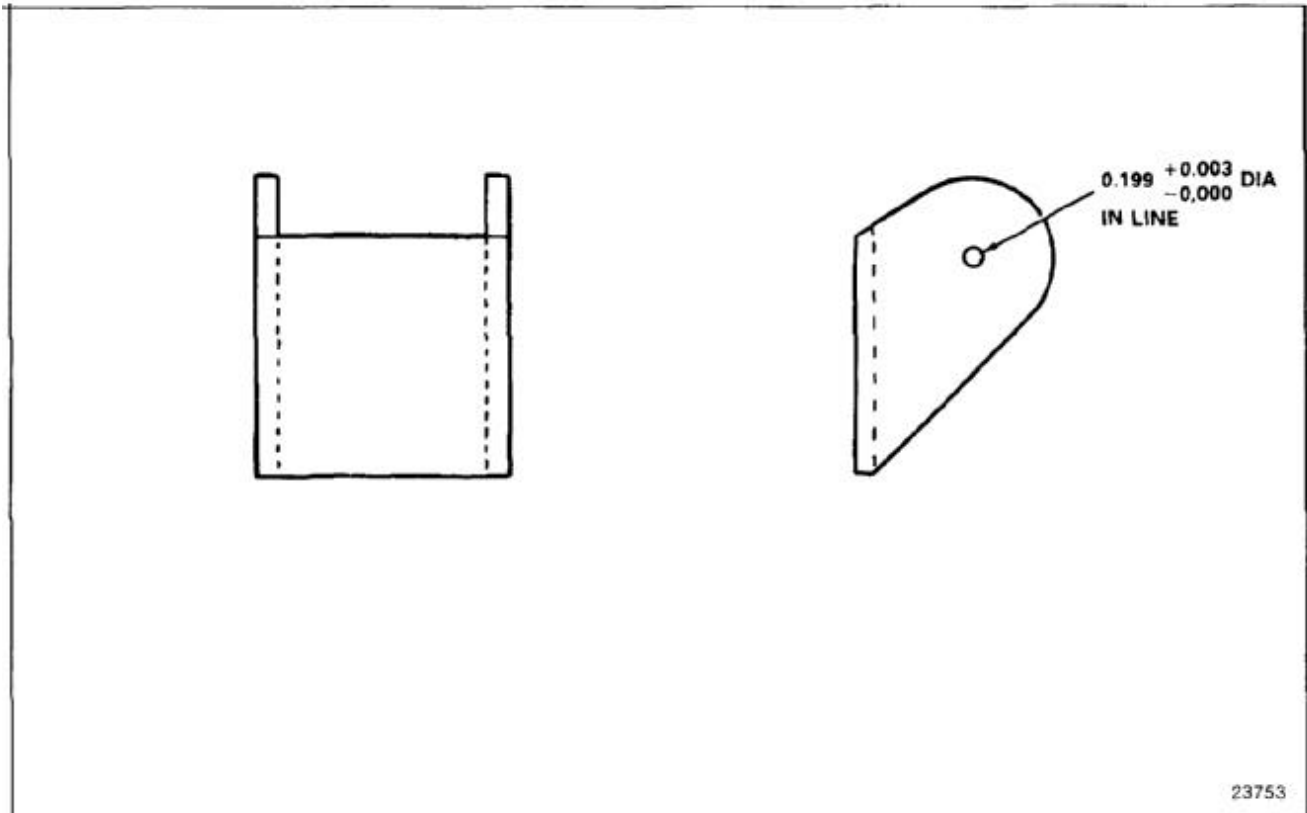

END OF TASK

NOTES:

1. FABRICATE ELECTRICAL LEAD, NSN 6150-00-661-0182, FROM PURE TINNED STRANDED SOFT COPPER WIRE SIZE AWG12 AND TERMINALS.
2. STOCK IS:
WIRE, AWG12, NSN 6145-00-819-0058
TERMINAL, MS25036-112,
(NSN 5940-00-204-8990). HOLE DIAMETER
IS 0.193 TO 0.203 AND ACCOMMODATES
NUMBER 10 OR 12 STUD.
3. ATTACH TERMINALS (MS25036-112) TO WIRE
WITH CRIMPING TOOL (MS25441).
4. ALL DIMENSIONS IN INCHES.

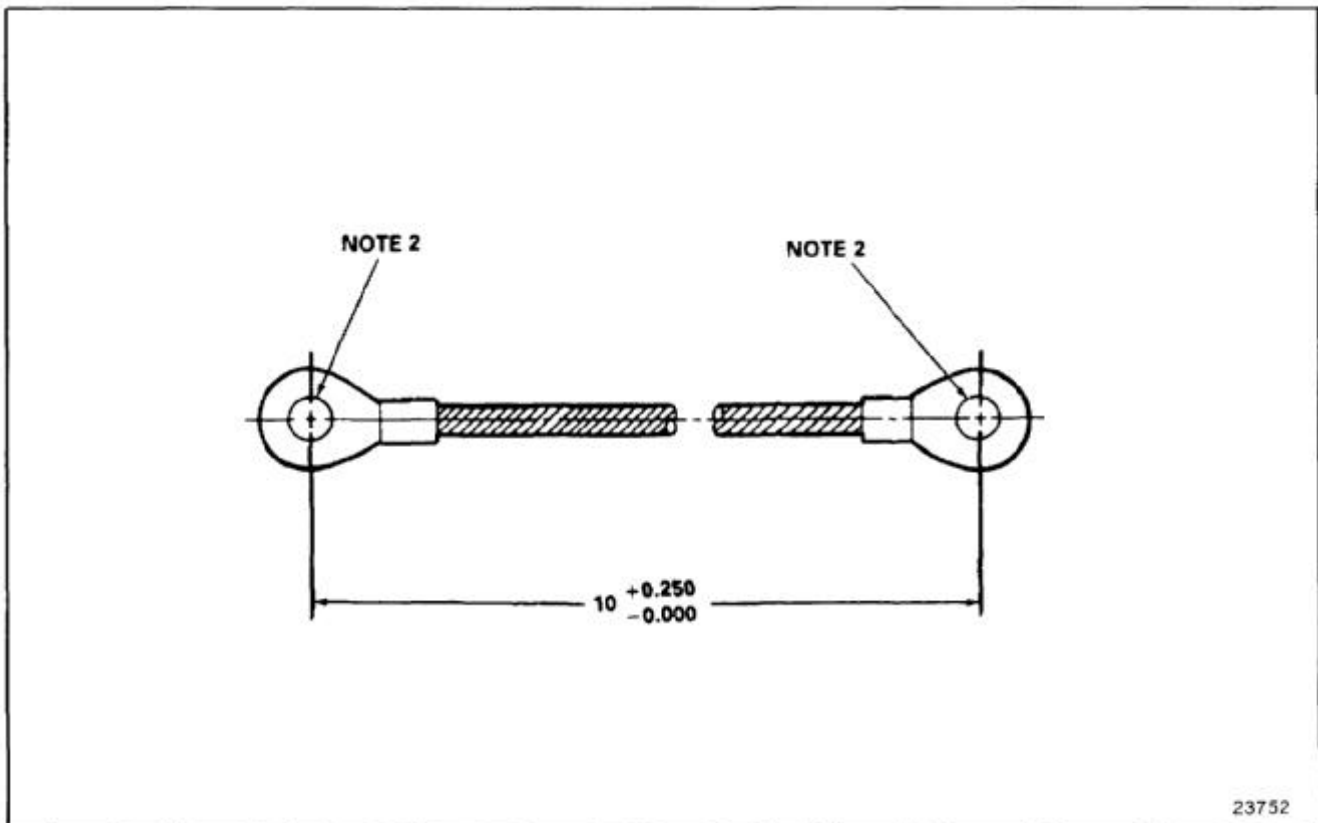

END OF TASK

E-366

NOTES:

1. FABRICATE FROM MS20001Y12-200.
2. ALL DIMENSIONS IN INCHES.
3. USE ORIGINAL PART TO DETERMINE PILOT HOLE LOCATIONS AND SHAPE.
4. FINISH AS REQUIRED.

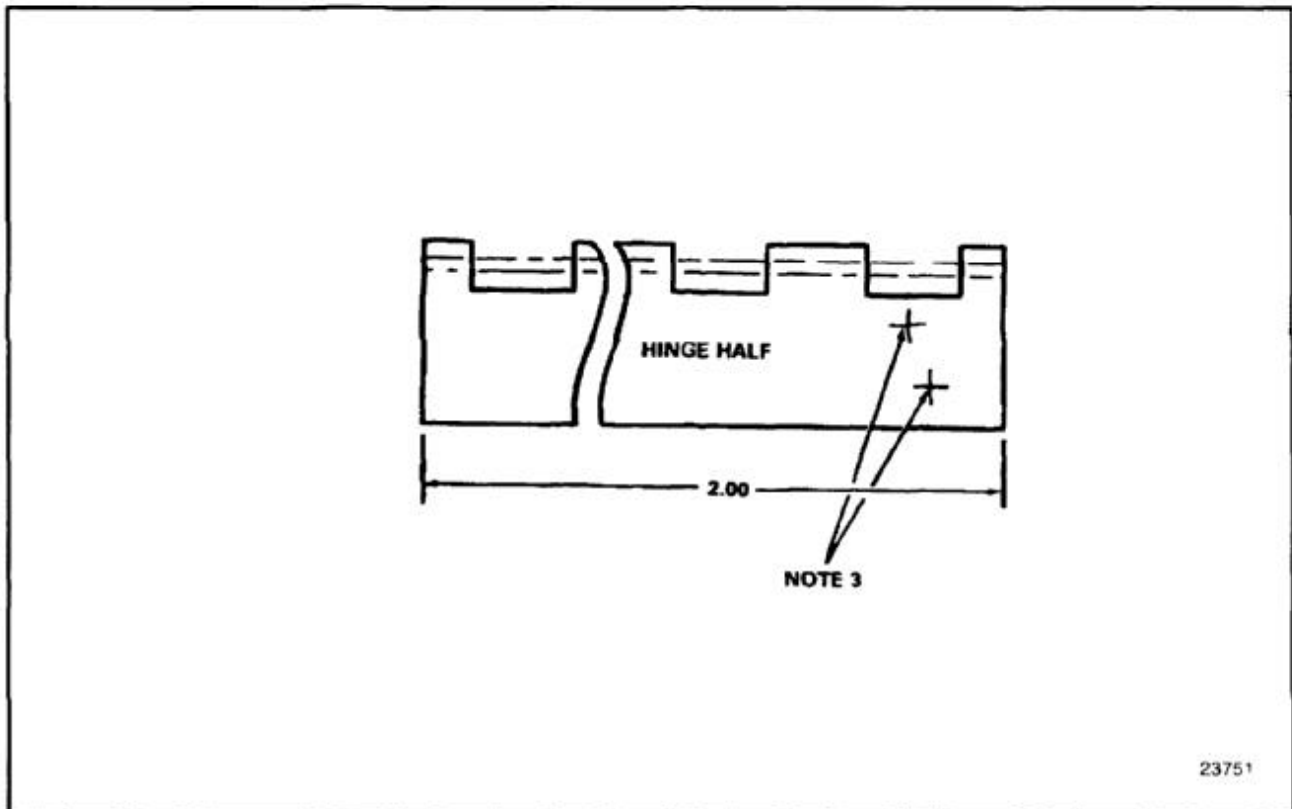

23751

END OF TASK

NOTES:

1. FABRICATE FROM MS20001X12-200.
2. ALL DIMENSIONS IN INCHES.
3. USE ORIGINAL PART TO DETERMINE PILOT HOLE LOCATIONS AND SHAPE.
4. LENGTH:
 114S5551-85 = 1.50
 114S5551-86 = 1.50 (OPP -85)
 114S5551-87 = 1.70 (OPP -88)
 114S5551-88 = 1.70
5. FINISH AS REQUIRED.

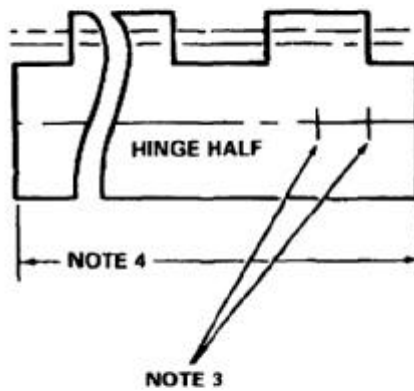

23750

END OF TASK

E-368

NOTES:

1. FABRICATE FROM MS20253P5-190(NSN 5340-00-133-1974).
2. ALL DIMENSIONS IN INCHES.
3. CUT PINS TO LENGTH AND ROUND ENDS. REMOVE ALL BURRS AND SHARP EDGES.
4. FINISH AS REQUIRED.

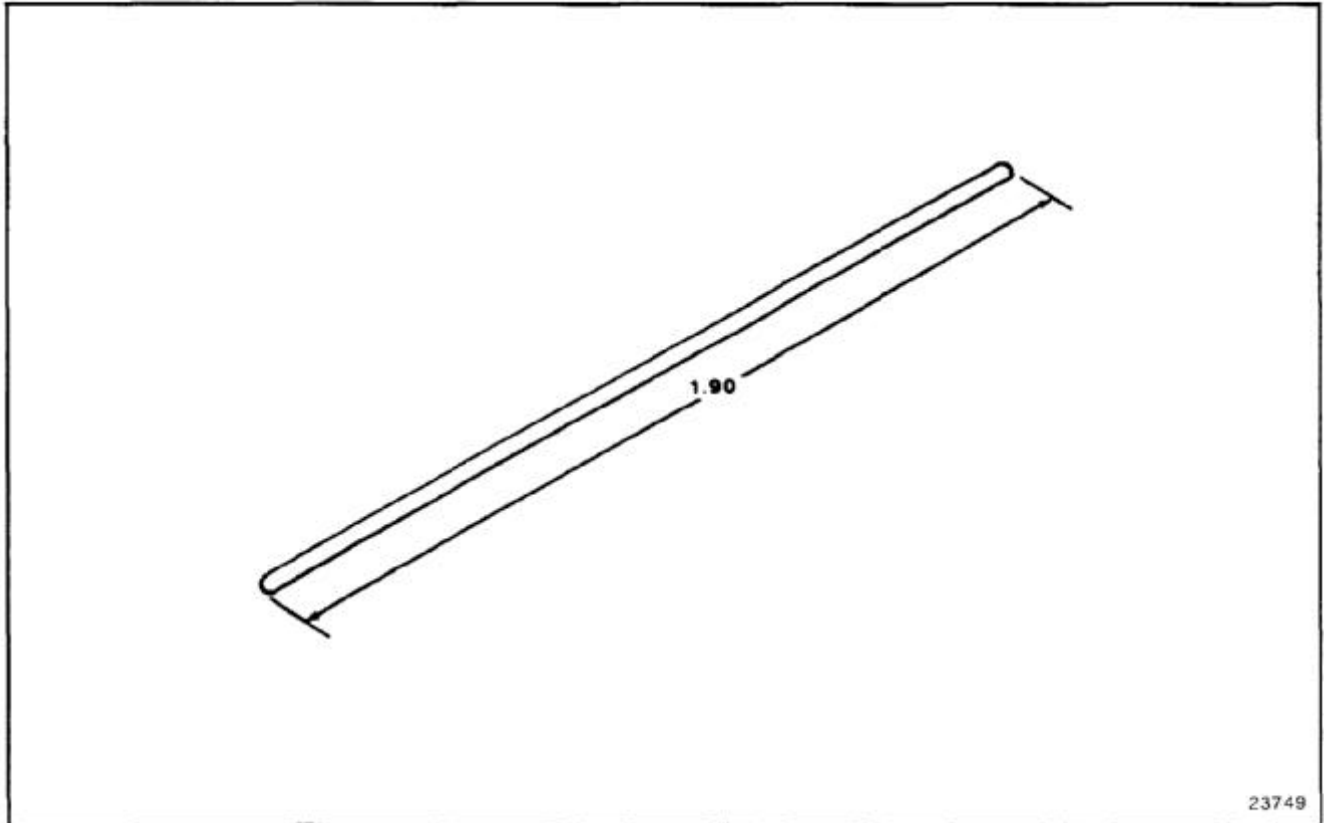

23749

END OF TASK

NOTES:

1. FABRICATE FROM ALCOA EXTRUSION NUMBER 32220, ALUMINUM ALLOY 7075-T6511 PER QQ-A-200/11.
2. ALL DIMENSIONS IN INCHES.
3. STOCK SIZE 1.9.
4. USE OLD TEE AS TEMPLATE WHEN MAKING NEW TEE.
5. MATCH DRILL ATTACH POINTS WITH MATCHING ASSEMBLY.
6. 145S3617-4 AND -5 ARE OPPOSITE.
7. FINISH AS REQUIRED.

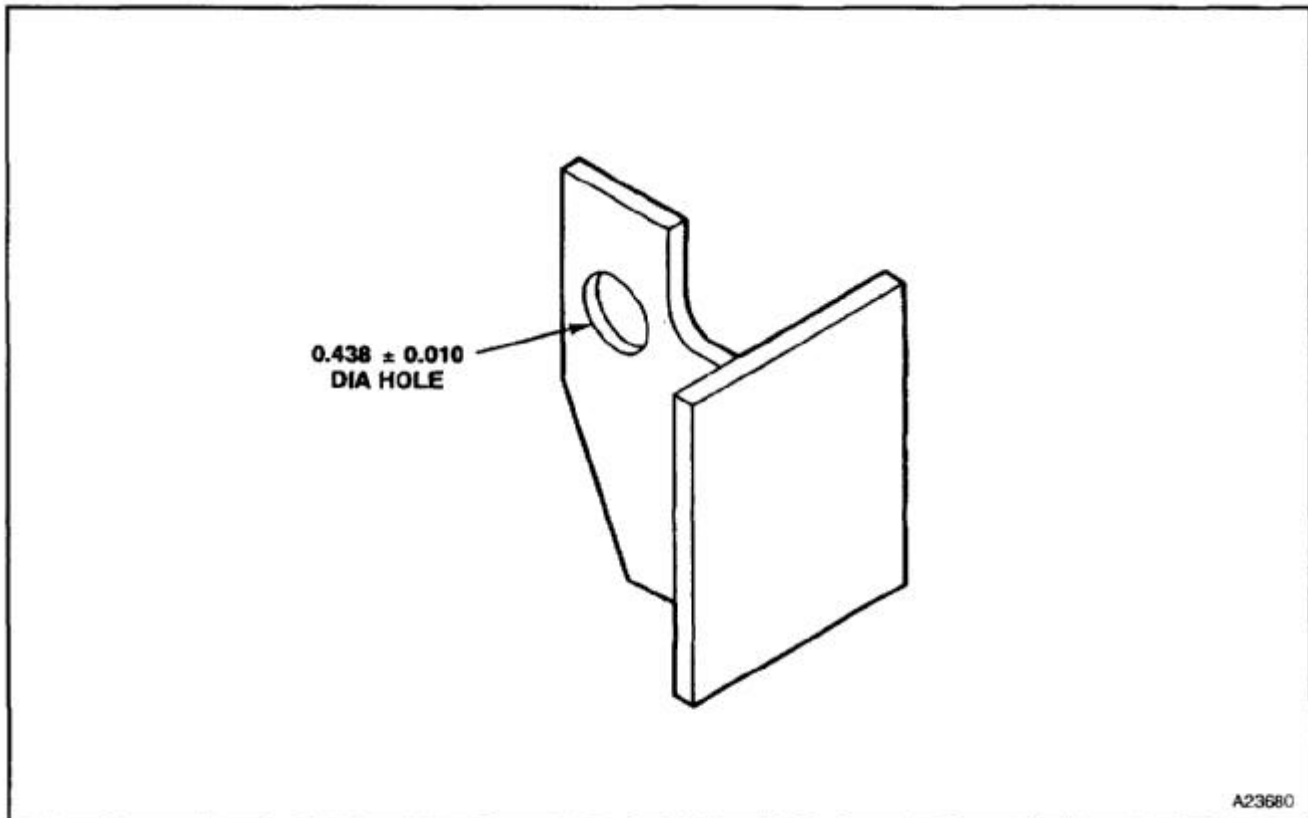

END OF TASK

E-370

NOTES:

1. FABRICATE FROM MS20001PX5-200.
2. ALL DIMENSIONS IN INCHES.
3. USE ORIGINAL PART TO DETERMINE PILOT HOLE LOCATIONS AND SHAPE.
4. FINISH AS REQUIRED.

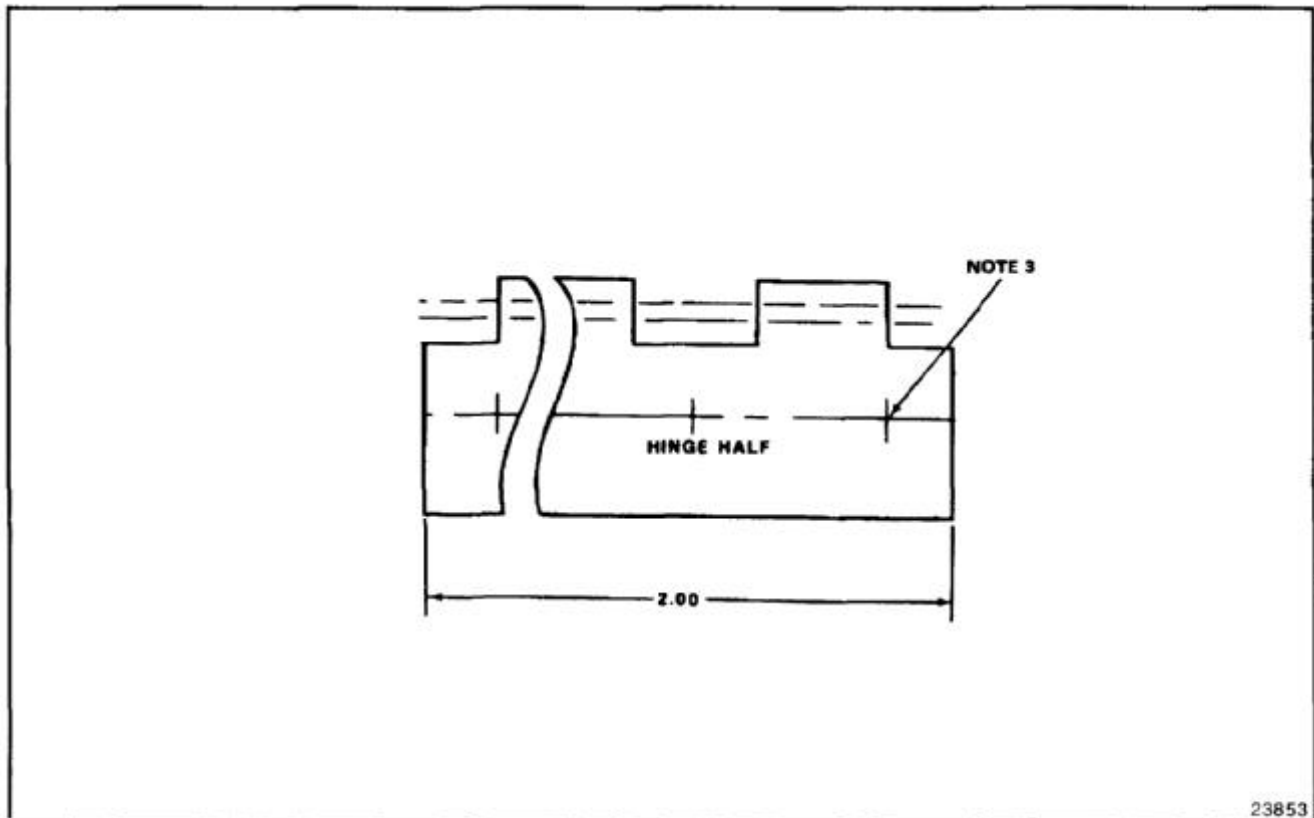

23853

END OF TASK

NOTES:

1. FABRICATE FROM MS20001PY5-200.
2. ALL DIMENSIONS IN INCHES.
3. USE ORIGINAL PART TO DETERMINE PILOT HOLE LOCATIONS AND SHAPE.
4. FINISH AS REQUIRED.

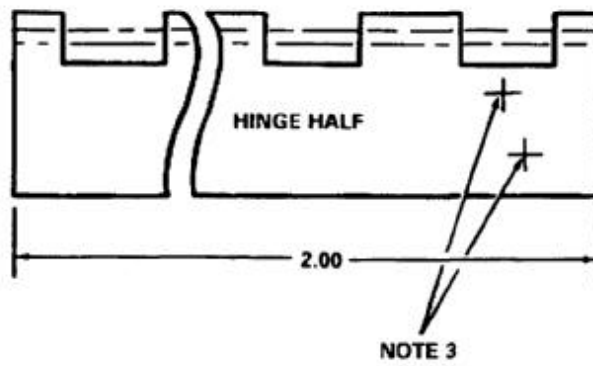

23751

END OF TASK

E-372

NOTES:

1. FABRICATE FROM MS20253P2-200,
NSN 5315-00-761-6876.
2. ALL DIMENSIONS IN INCHES.
3. CUT PINS TO LENGTH AND ROUND ENDS.
REMOVE ALL BURRS AND SHARP EDGES.
4. FINISH AS REQUIRED.

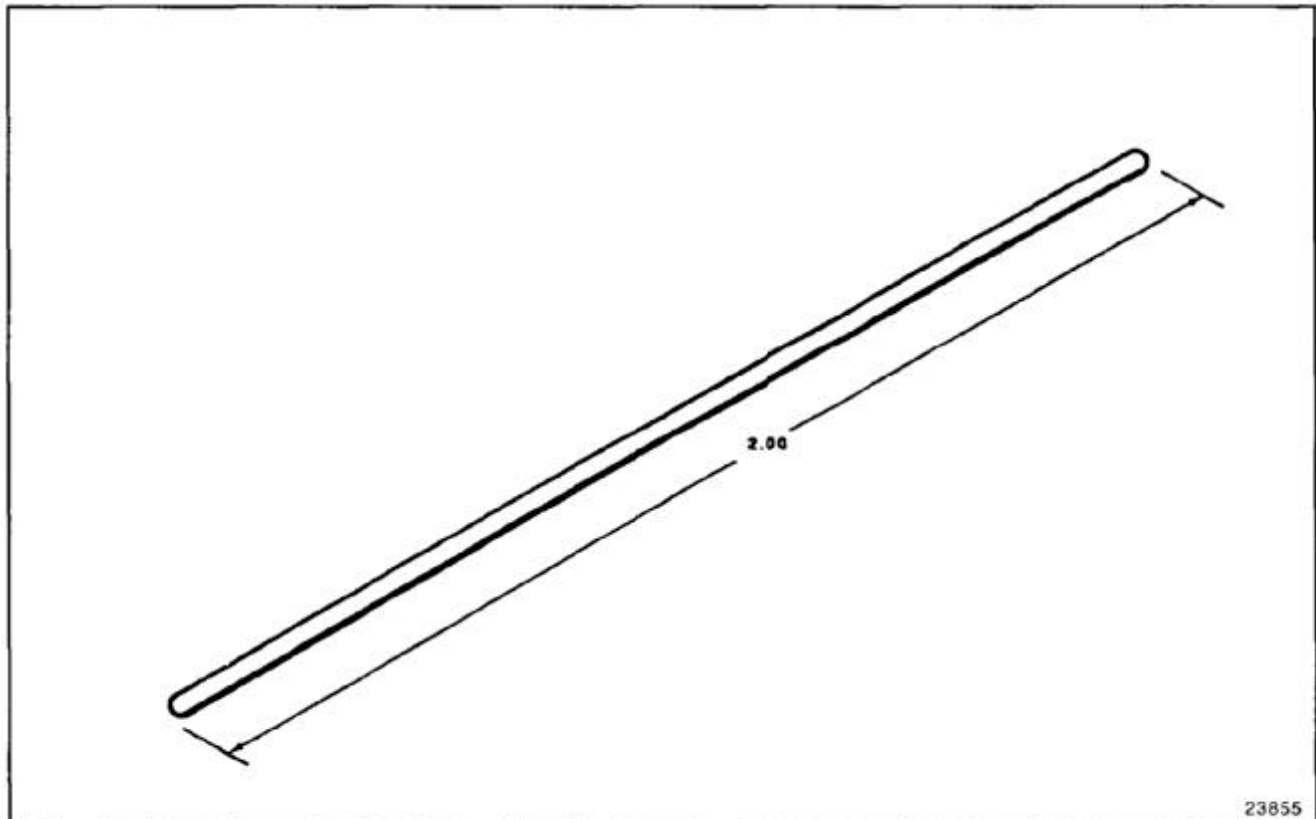

END OF TASK

NOTES:

1. FABRICATE FROM MS20001PH10-1700.
2. ALL DIMENSIONS IN INCHES.
3. USE ORIGINAL PART TO DETERMINE PILOT HOLE LOCATIONS AND SHAPE.
4. FINISH AS REQUIRED.

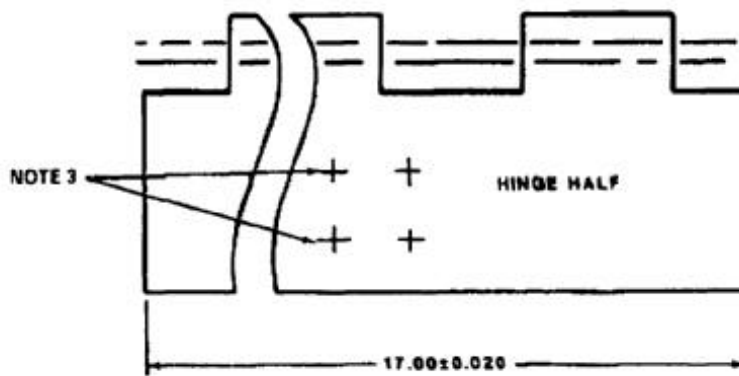

23844

END OF TASK

E-374

NOTES:

1. FABRICATE FROM VS80546-1,
NSN 9390-00-759-9765.
2. ALL DIMENSIONS IN INCHES.
3. 114S5910-27 LENGTH = 16.00
114S5910-28 LENGTH = 2.80

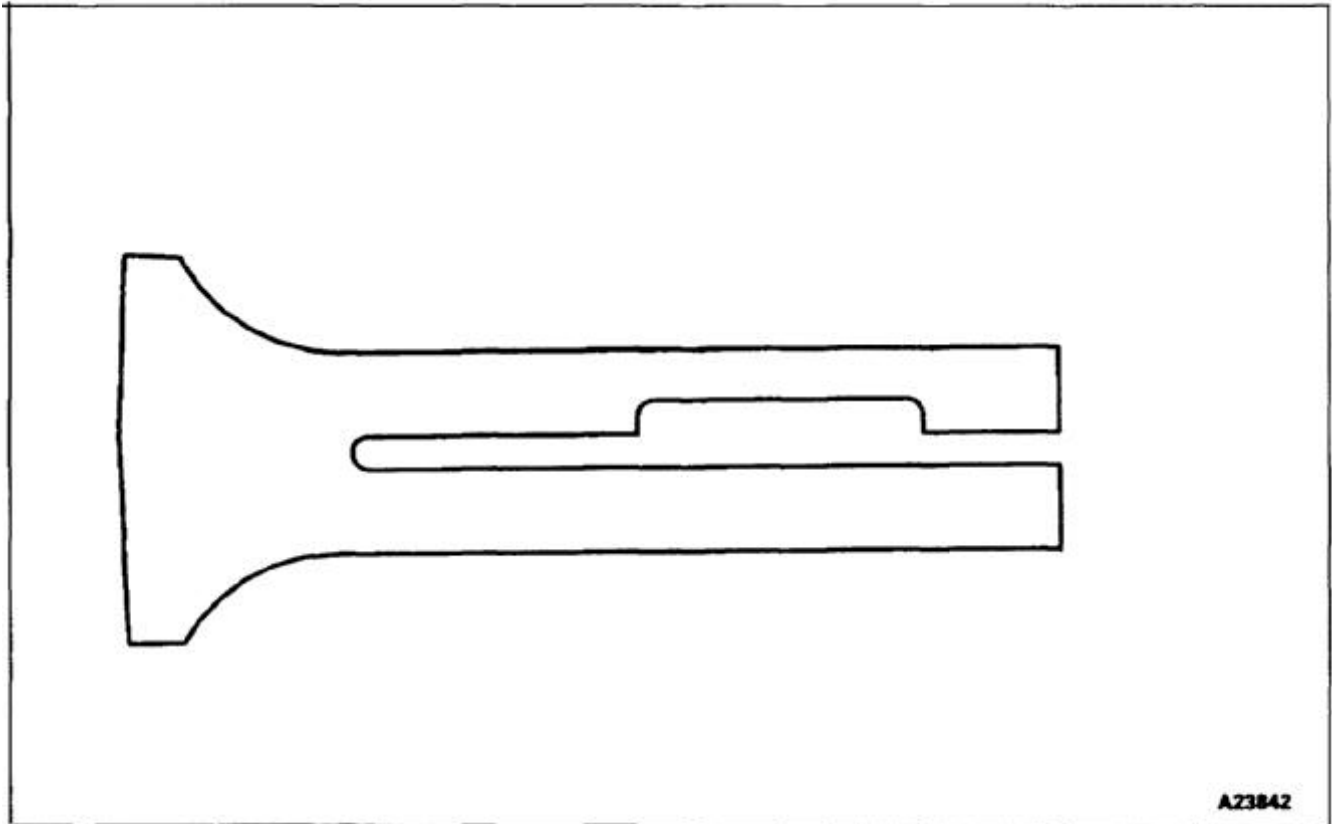

END OF TASK

NOTES:

1. FABRICATE FROM MS20001PH10-1700.
2. ALL DIMENSIONS IN INCHES.
3. USE ORIGINAL PART TO DETERMINE PILOT HOLE LOCATIONS AND SHAPE.
4. FINISH AS REQUIRED.

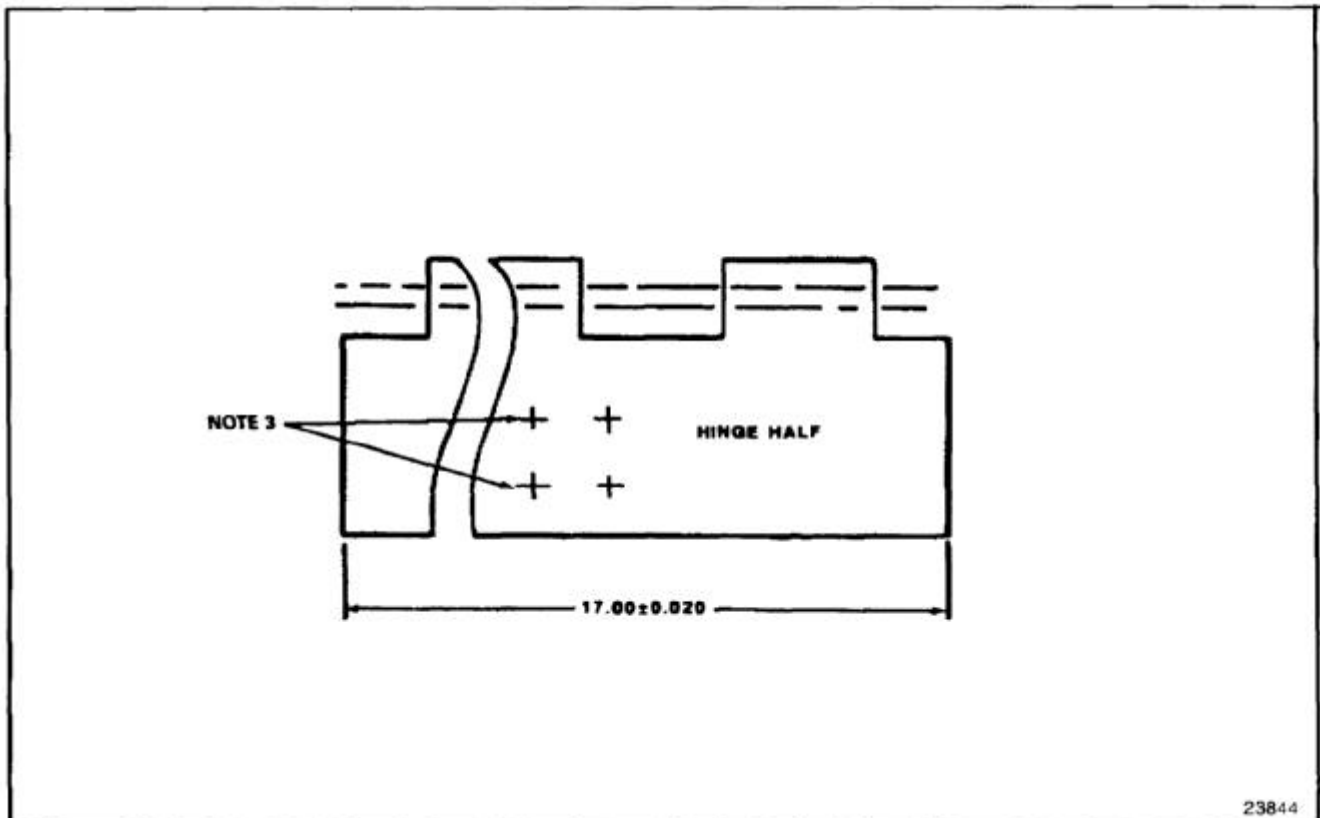

23844

END OF TASK

E-376

NOTES:

1. FABRICATE HINGE PIN FROM MS20253P2-1700NSN 5340-00-133-1974.
2. ALL DIMENSIONS IN INCHES.
3. CUT PINS TO LENGTH AND ROUND ENDS. REMOVE ALL BURRS AND SHARP EDGES.
4. FINISH AS REQUIRED.

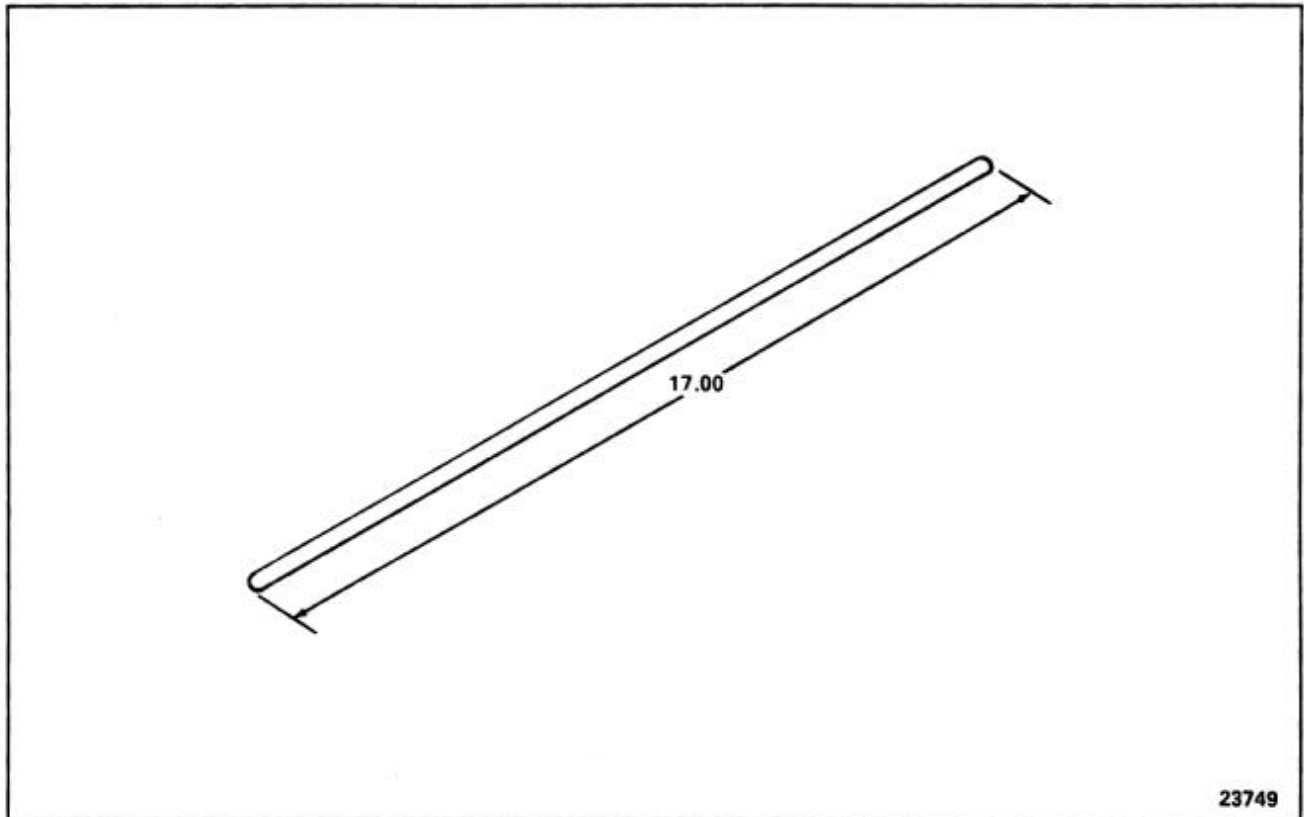

END OF TASK

NOTES:

1. FABRICATE ELECTRIC LEAD, NSN 6150-01-136-5909, FROM PURE TINNED STRANDED SOFT COPPER WIRE SIZE AWG12, TERMINALS, AND QUICK DISCONNECT SPLICE SET, NSN 5340-00-133-1974.
2. STOCK IS:
WIRE, AWG12, NSN 6145-00-819-0058
TERMINAL, MS250036-112(NSN 5940-00-143-4794), HOLE DIAMETER IS 0.193 TO 0.203 AND ACCOMMODATES NUMBER 8 OR 10 STUD. QUICK DISCONNECT SPLICE SET, NSN 5940-00-611-3945.
3. ATTACH TERMINALS (MS25036-112) TO WIRE WITH CRIMPING TOOL (MS25441).
4. ALL DIMENSIONS IN INCHES.

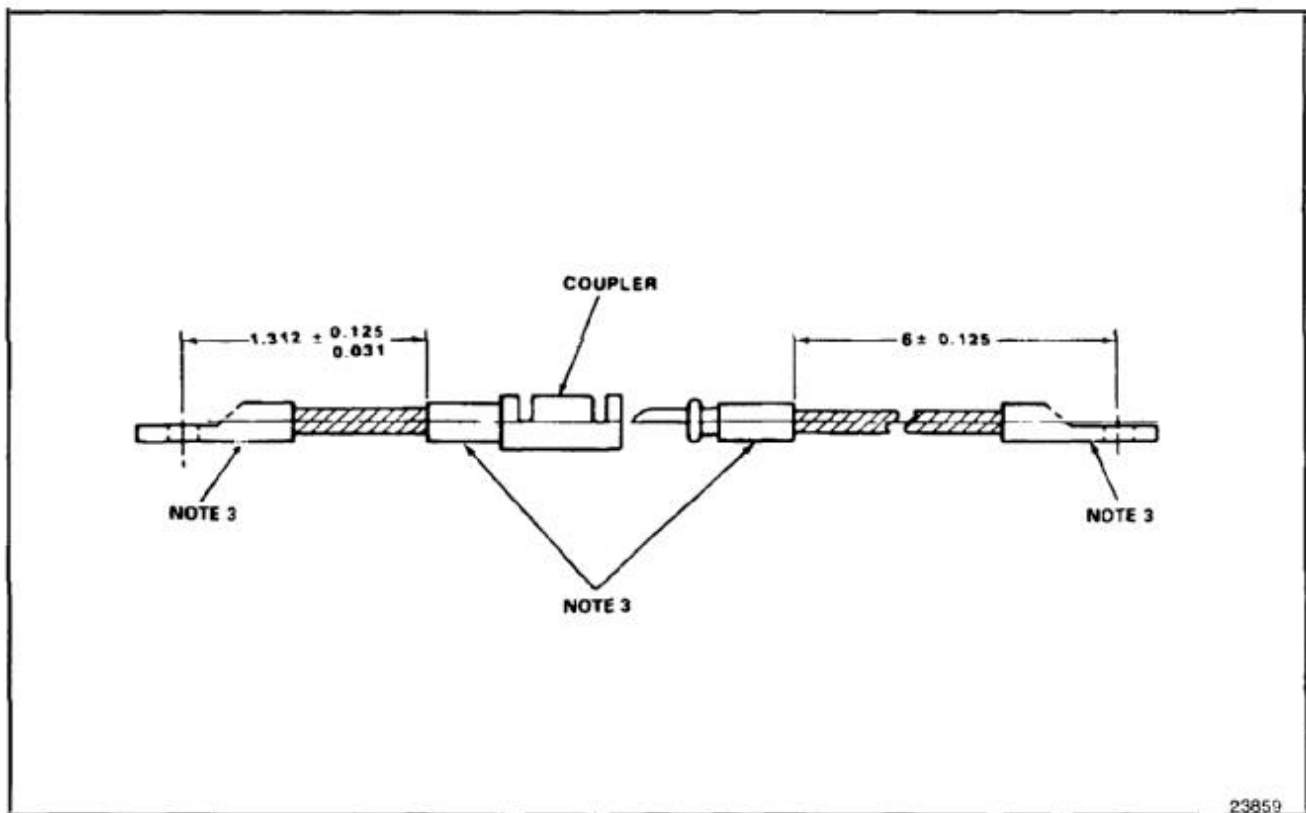

END OF TASK

E-378

NOTES:

1. FABRICATE ELECTRIC LEAD, NSN 6150-01-136-5909, FROM PURE TINNED STRANDED SOFT COPPER WIRE SIZE AWG12, TERMINALS, AND QUICK DISCONNECT SPLICE SET.
2. STOCK IS: WIRE, AWG12, NSN 6145-00-819-0058 TERMINAL, MS25036-112, NSN 5940-00-143-4794, HOLE DIAMETER IS 0.193 TO 0.203 AND ACCOMMODATES NUMBER 8 OR 10 STUD. QUICK DISCONNECT SPLICE SET, NSN 5940-00-611-3945.
3. ATTACH TERMINALS (MS25036-112) TO WIRE WITH CRIMPING TOOL (MS25441).
4. ALL DIMENSIONS IN INCHES.

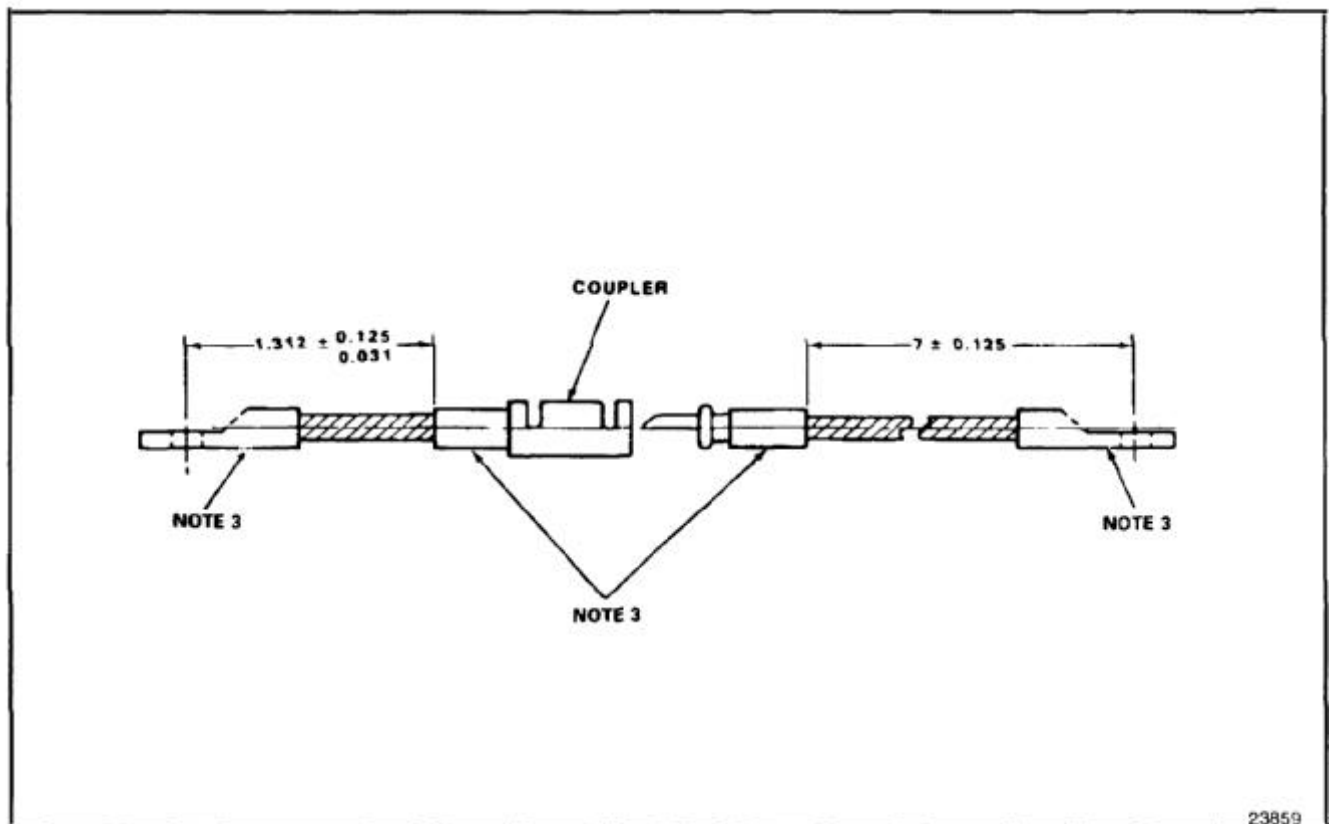

END OF TASK

NOTES:

1. FABRICATE ELECTRICAL LEAD, NSN 6150-00-642-1310, FROM PURE TINNED STRANDED SOFT COPPER WIRE SIZE AWG12 AND TERMINALS.
2. STOCK IS: WIRE, AWG12, NSN 6145-00-819-0058, TERMINAL, MS25036-111(NSN 5940-00-204-8990), HOLE DIAMETER IS 0.142 TO 0.152 AND ACCOMMODATES NUMBER 4 OR 6 STUD. TERMINAL, MS25036-157(NSN 5940-00-143-4777), HOLE DIAMETER 0.250 TO 0.285 ACCOMMODATES 0.250 STUD.
3. ATTACH TERMINALS (MS25036-111 AND -157) TO WIRE WITH CRIMPING TOOL (MS25441).
4. ALL DIMENSIONS IN INCHES.

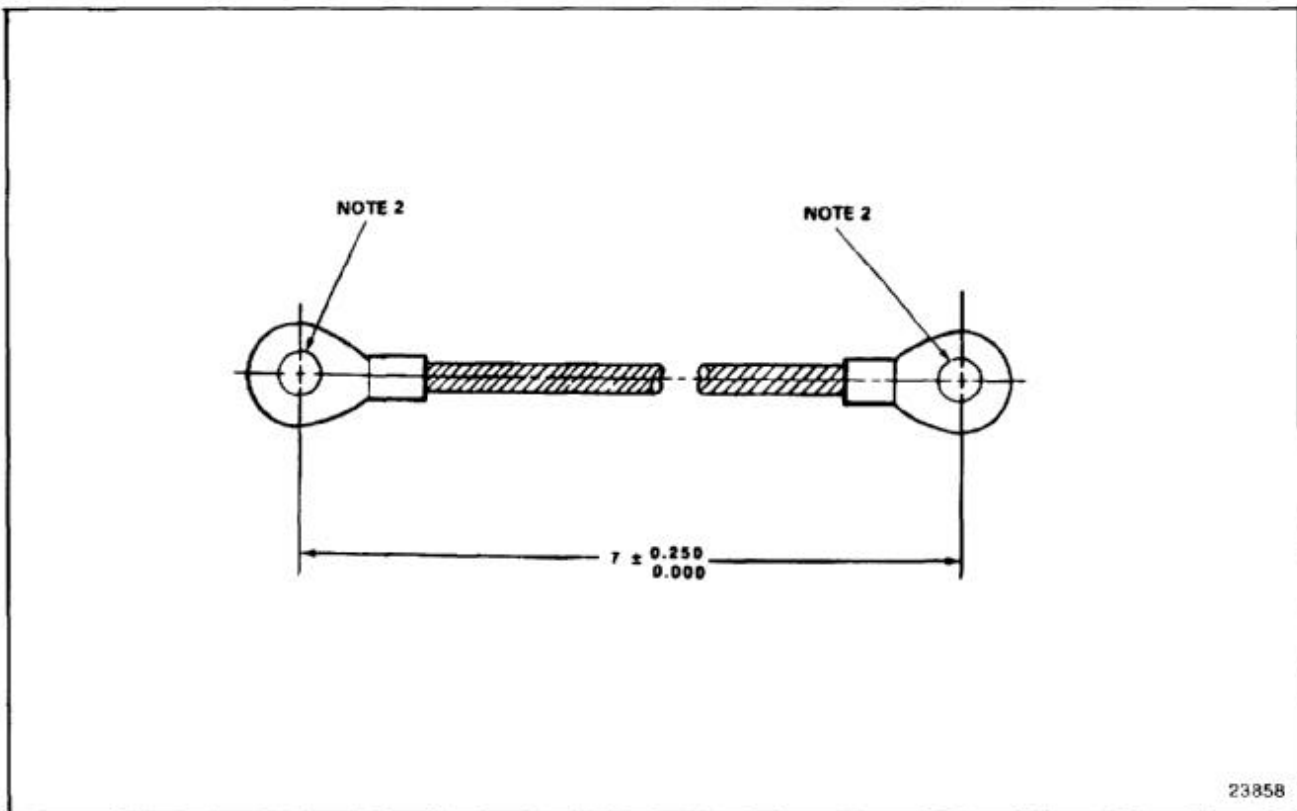

END OF TASK

E-380

**E-303 ENGINE PYLON FAIRING INSTALLATION SEALS 114S3902-241, -247, -365, -366,478,
AND -380****E-303****NOTES:**

1. FABRICATE FROM SYNTHETIC RUBBER,
NSN 5330-00-261-5471 SHEET PER
ML-R-6855, CLASS 1, GRADE 40.
2. ALL DIMENSIONS IN INCHES.
3. DIMENSIONS FOR SEALS:
114S3902-241 - 0.062 x 0.5 x 2.7
114S3902-247 - 0.032 x 0.5 x 38
114S3902-365 - 0.032 x 0.5 x 3.5
114S3902-366 - 0.032 x 0.5 x 14
114S3902-379 - 0.032 x 0.5 x 6.1
114S3902-380 - 0.032 x 0.5 x 7.5
4. USE ORIGINAL PART TO DETERMINE SHAPE.

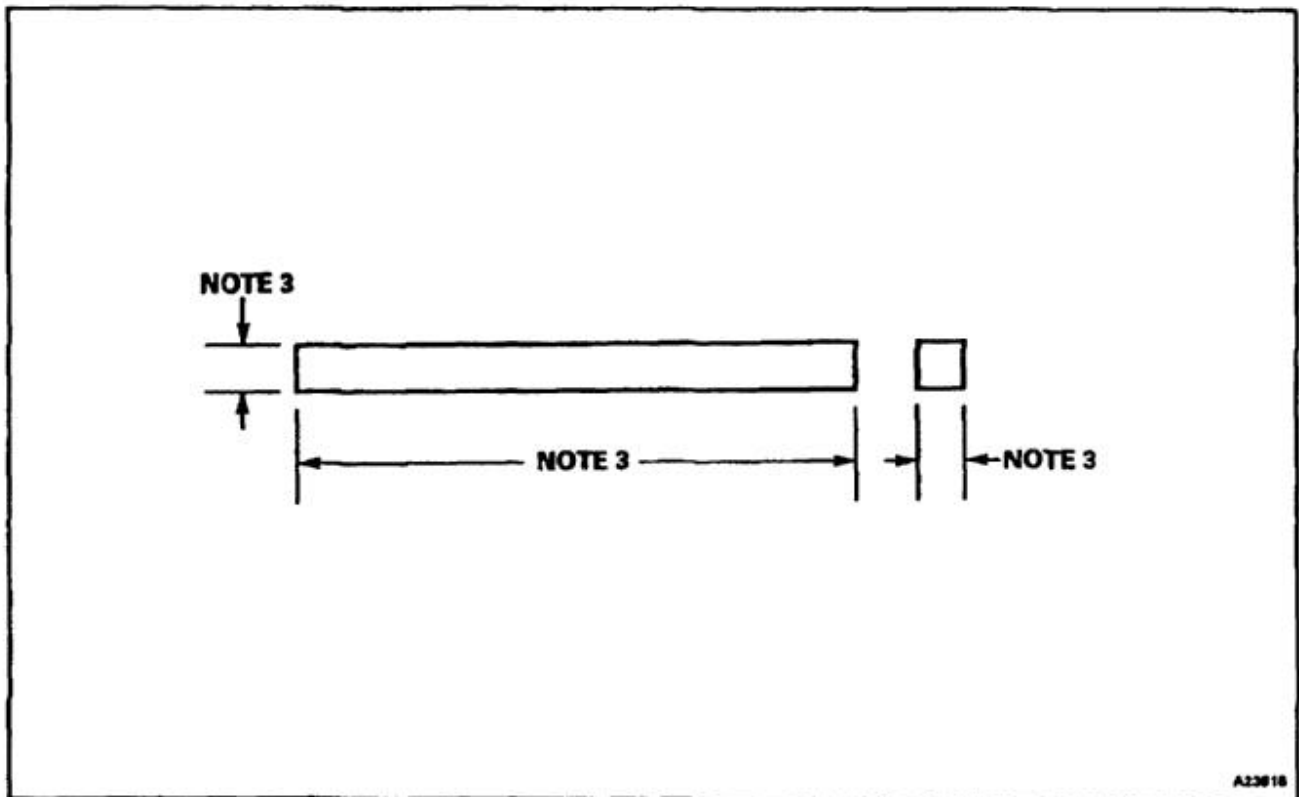

END OF TASK

NOTES:

1. FABRICATE FROM SYNTHETIC RUBBER (NSN 5330-00-261-5471) SHEET PER MIL-R-6855, CLASS 1, GRADE 40.
2. ALL DIMENSIONS IN INCHES.
3. DIMENSIONS FOR SEALS:
234S3902-19 = 0.032 X 1.1 X 20.4
23483902-20 = 0.032 X 1.0 X 19.3
4. USE ORIGINAL PART TO DETERMINE SHAPE.

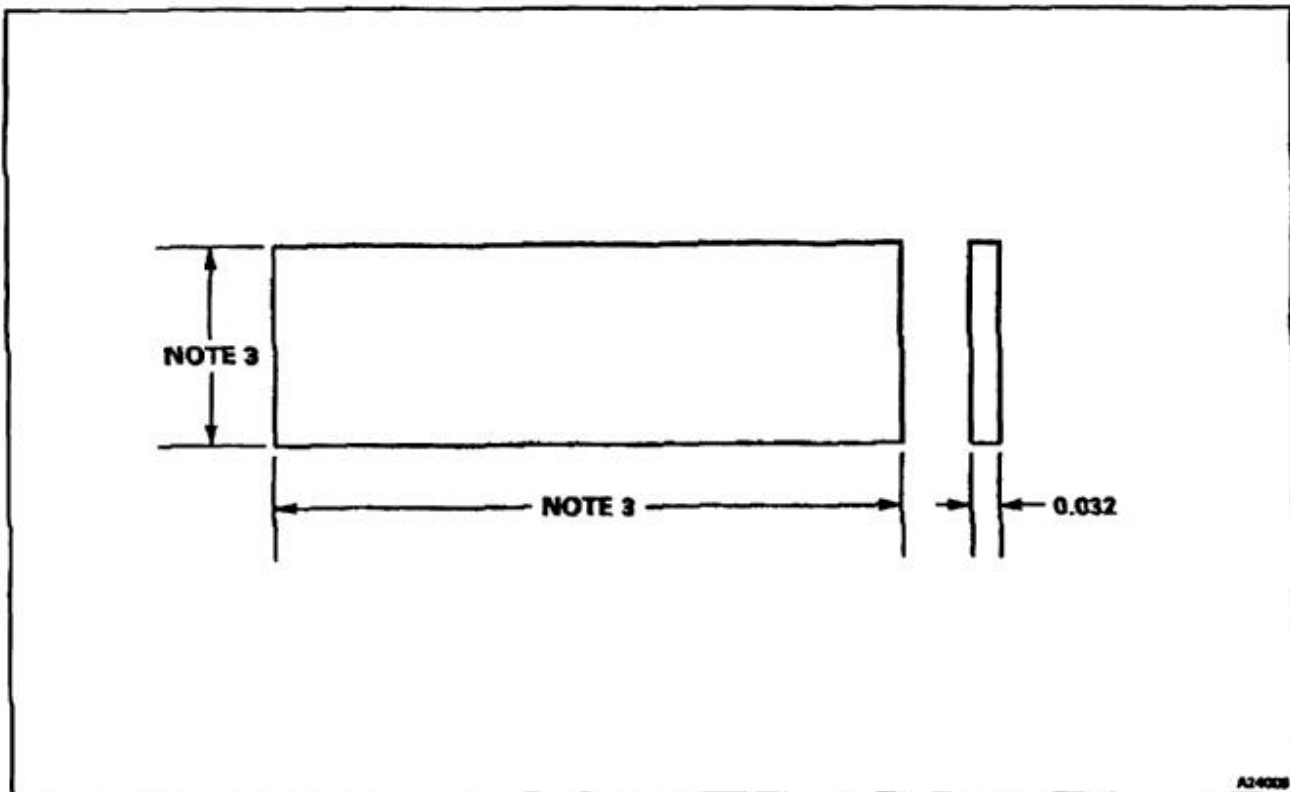

END OF TASK

E-382

NOTES:

1. FABRICATE FROM AN253-2 OR MS20253-2(NSN 5340-00-804-9880).
2. ALL DIMENSIONS IN INCHES.
3. CUT PINS TO LENGTH AND ROUND ENDS. REMOVE ALL BURRS AND SHARP EDGES.
4. FINISH AS REQUIRED.

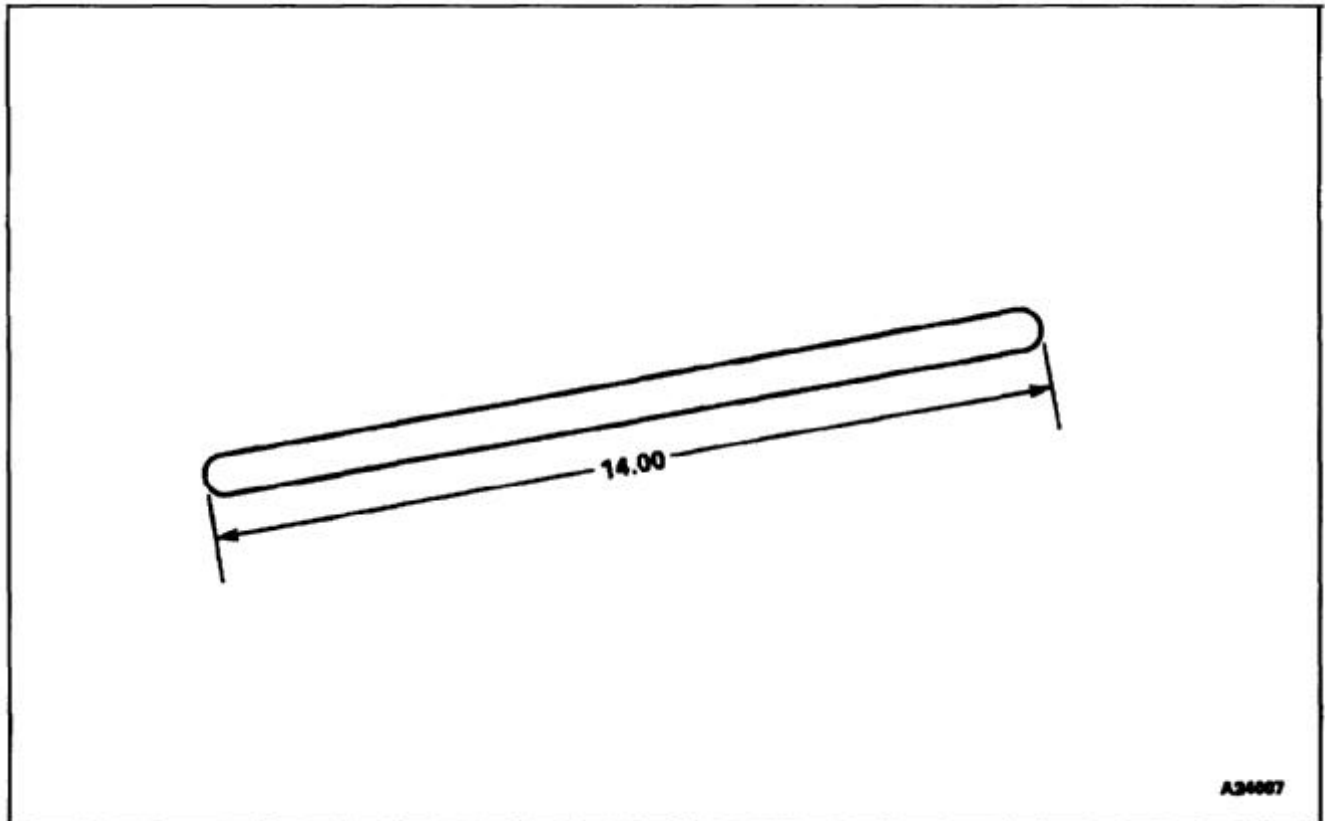

END OF TASK

NOTES:

1. FABRICATE FROM MS20001PH3-7200 (NSN 5340-00-899-4454).
2. THE -94 HALF HINGE IS OPPOSITE OF THE -93 HALF HINGE.
3. USE ORIGINAL PART TO DETERMINE PILOT HOLE LOCATIONS AND SHAPE. LENGTH IS 14.00.
4. FINISH AS REQUIRED.

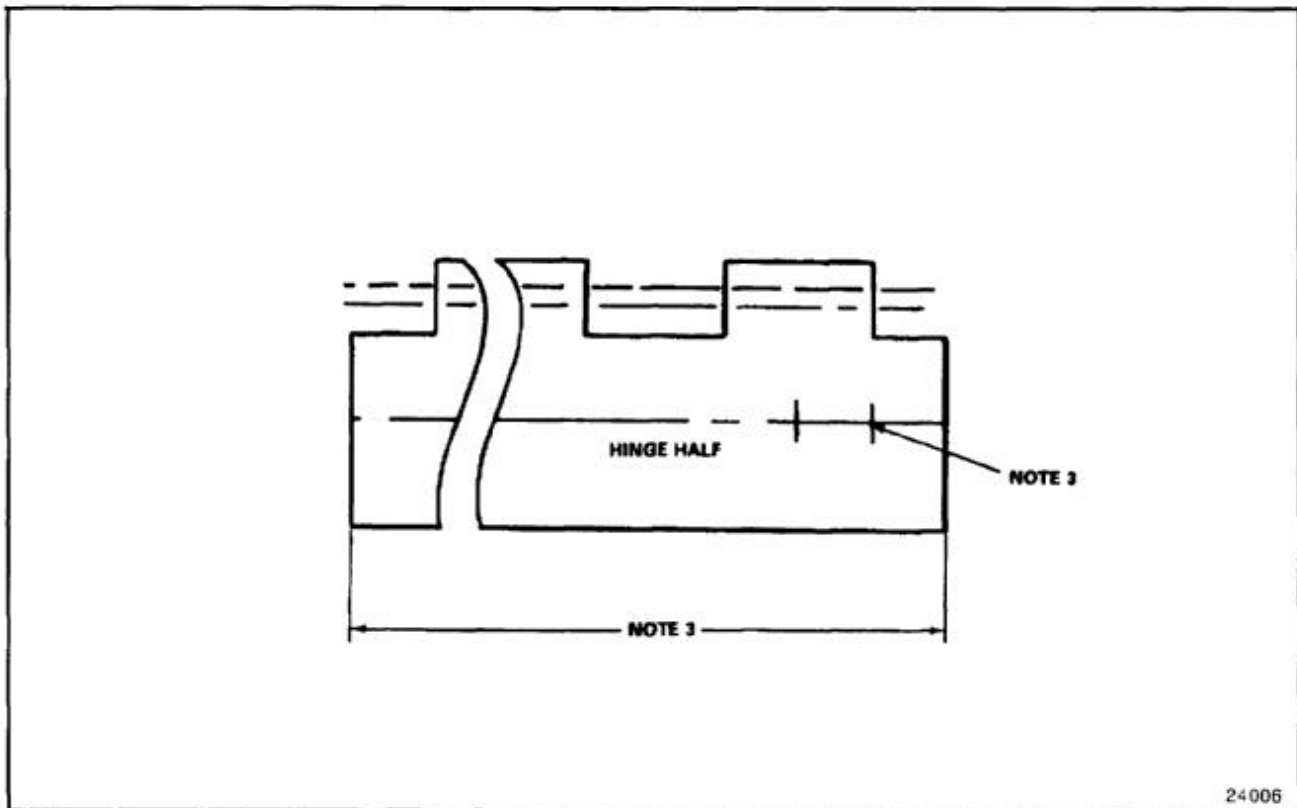

END OF TASK

E-384

NOTES:

1. FABRICATE FROM SYNTHETIC RUBBER (NSN 5530-00-261-5471) SHEET PER MIL-R-6855, CLASS 1, GRADE 40.
2. ALL DIMENSIONS IN INCHES.

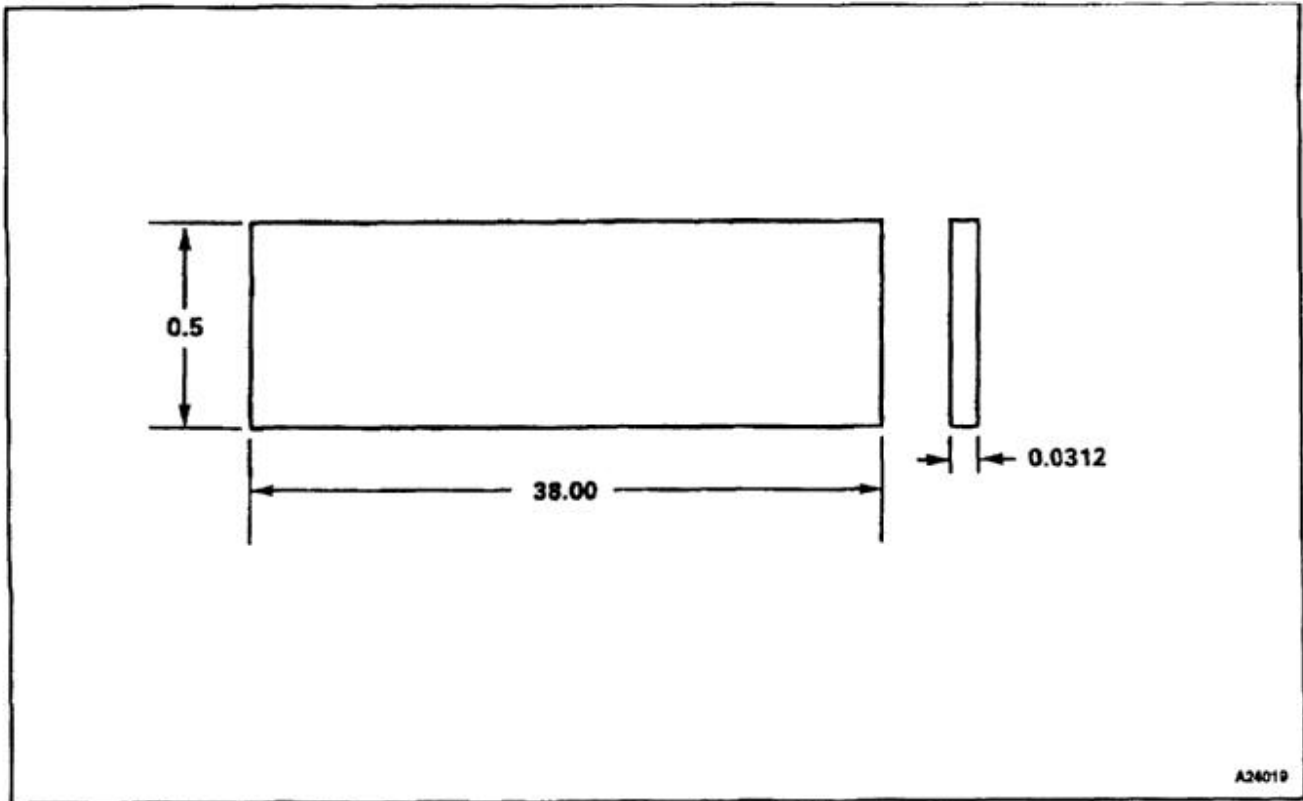

END OF TASK

NOTES:

1. FABRICATE FROM MS20001PH5
 (NSN 5340-00-582-3721).
2. ALL DIMENSIONS IN INCHES. THE -63 HALF
 HINGE IS OPPOSITE OF THE -64 HALF
 HINGE.
3. USE ORIGINAL PART TO DETERMINE PILOT
 HOLE LOCATIONS AND SHAPE. LENGTH IS
 14.20
4. FINISH AS REQUIRED.

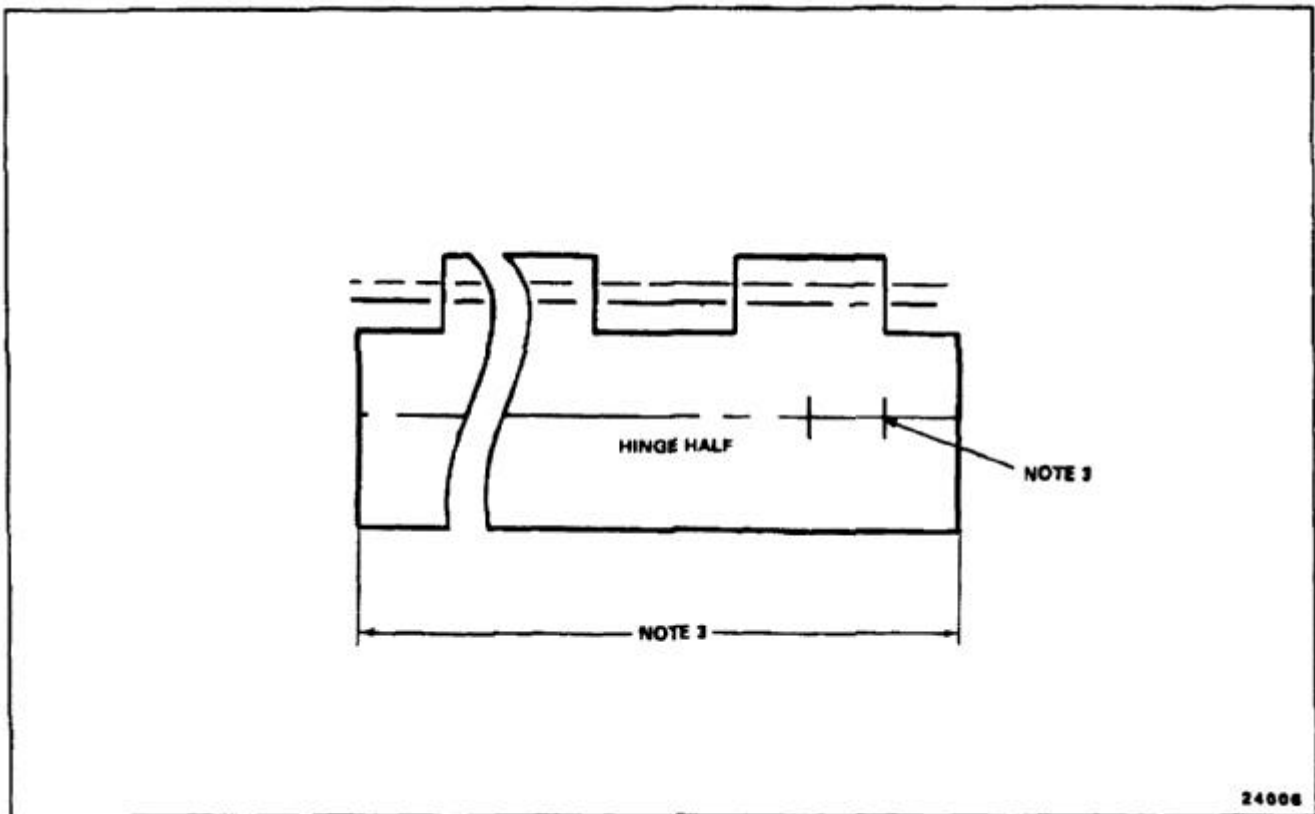

END OF TASK

E-386

NOTES:

1. FABRICATE FROM RUBBER GASKET VS80567-1, NSN 5330-00-759-0786.
2. USE ORIGINAL PART TO DETERMINE LENGTH AND SHAPE.
3. IDENTIFY THE NEW PART WITH A SUITABLE MARKING INK.

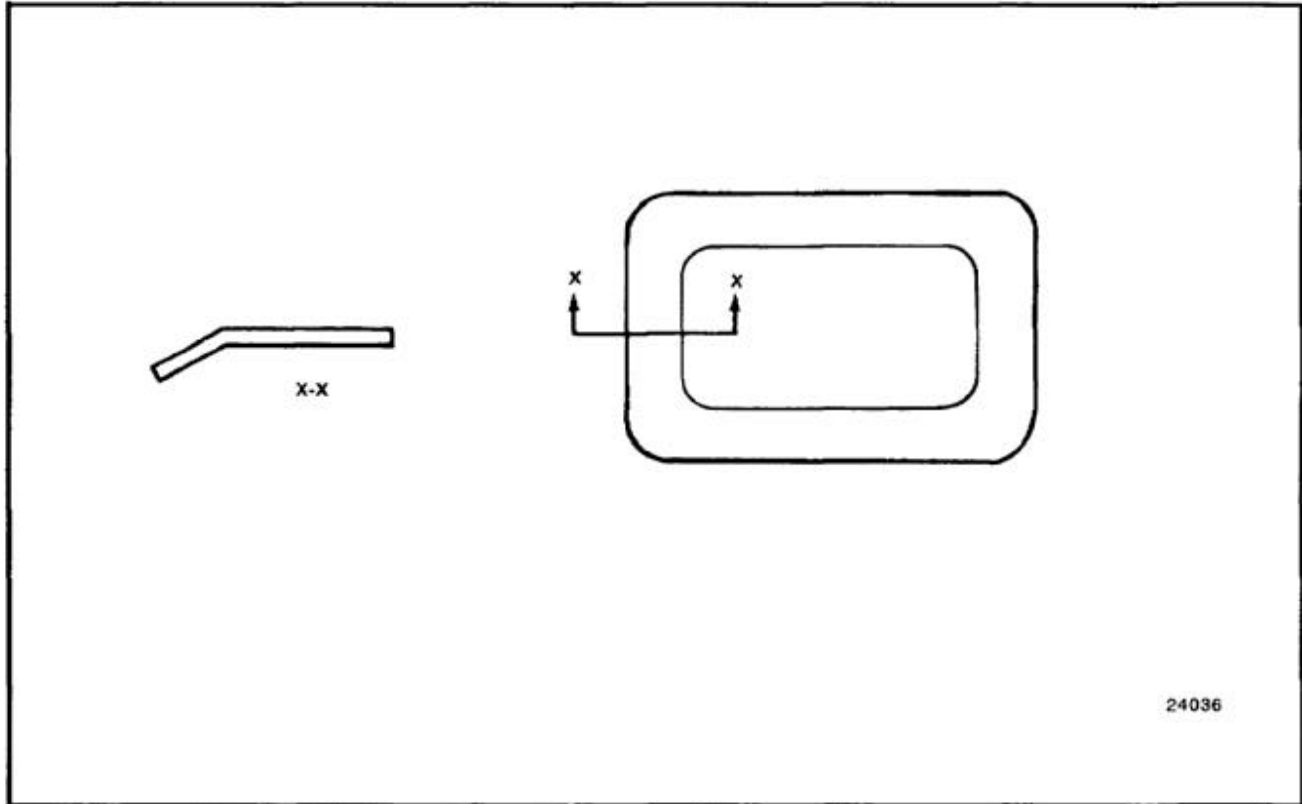

END OF TASK

NOTES:

1. FABRICATE FROM ALUMINUM LAMINATED SHIM PER MIL-S-22499 COMPOSITION 1, TYPE 1.
2. ALL DIMENSIONS IN INCHES.
3. STOCK SIZE 0.092 X 1.4 X 3.3
4. FINISH AS REQUIRED.

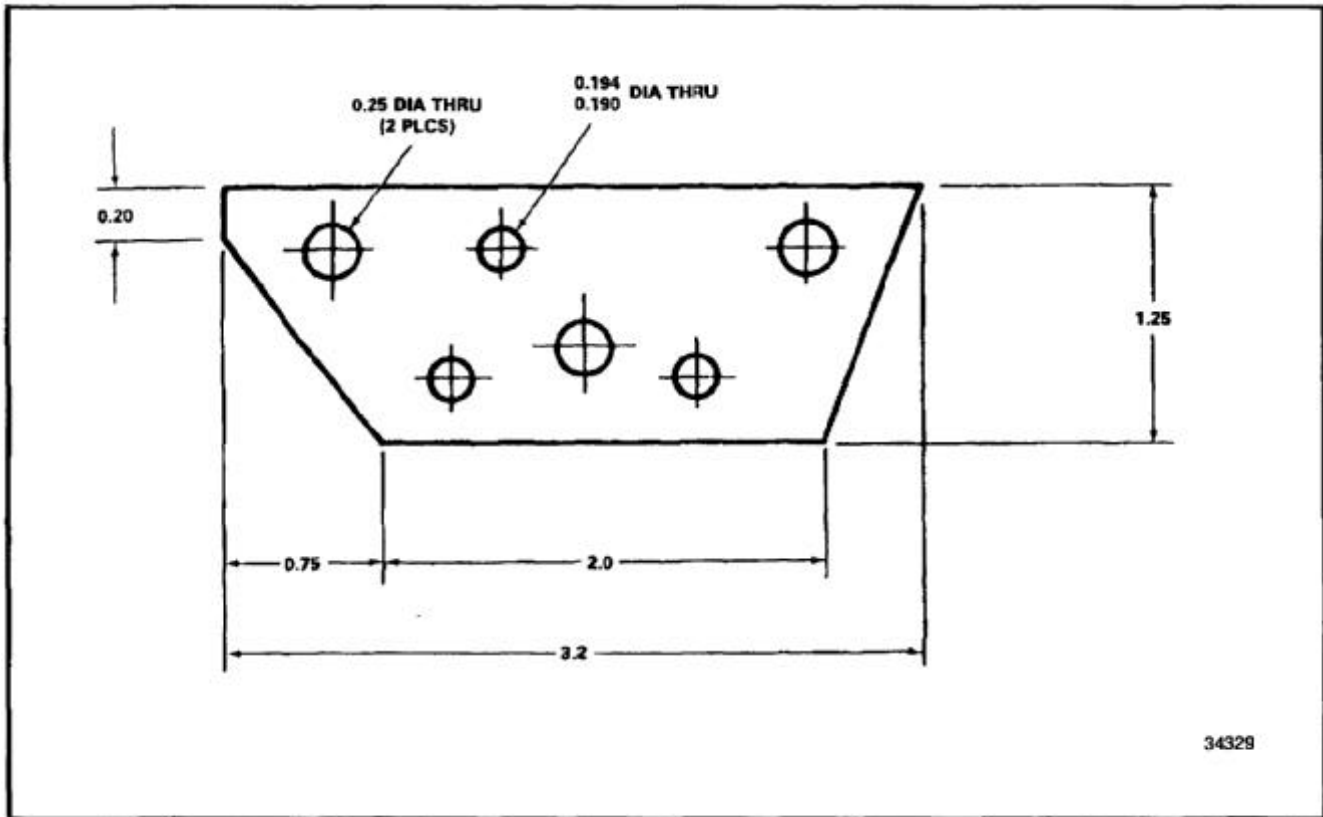

END OF TASK

E-388

NOTES:

1. FABRICATE FROM CLEAR MODIFIED ACRYLIC SHEET 0.25 THICKNESS.
2. ALL DIMENSIONS IN INCHES.
3. BREAK ALL SHARP EDGES NOT SPECIFIED, TO A RADIUS OR CHAMFER OF 0.010 TO 0.020.
4. ±TOLERANCES 0.005; HOLES± 0.002

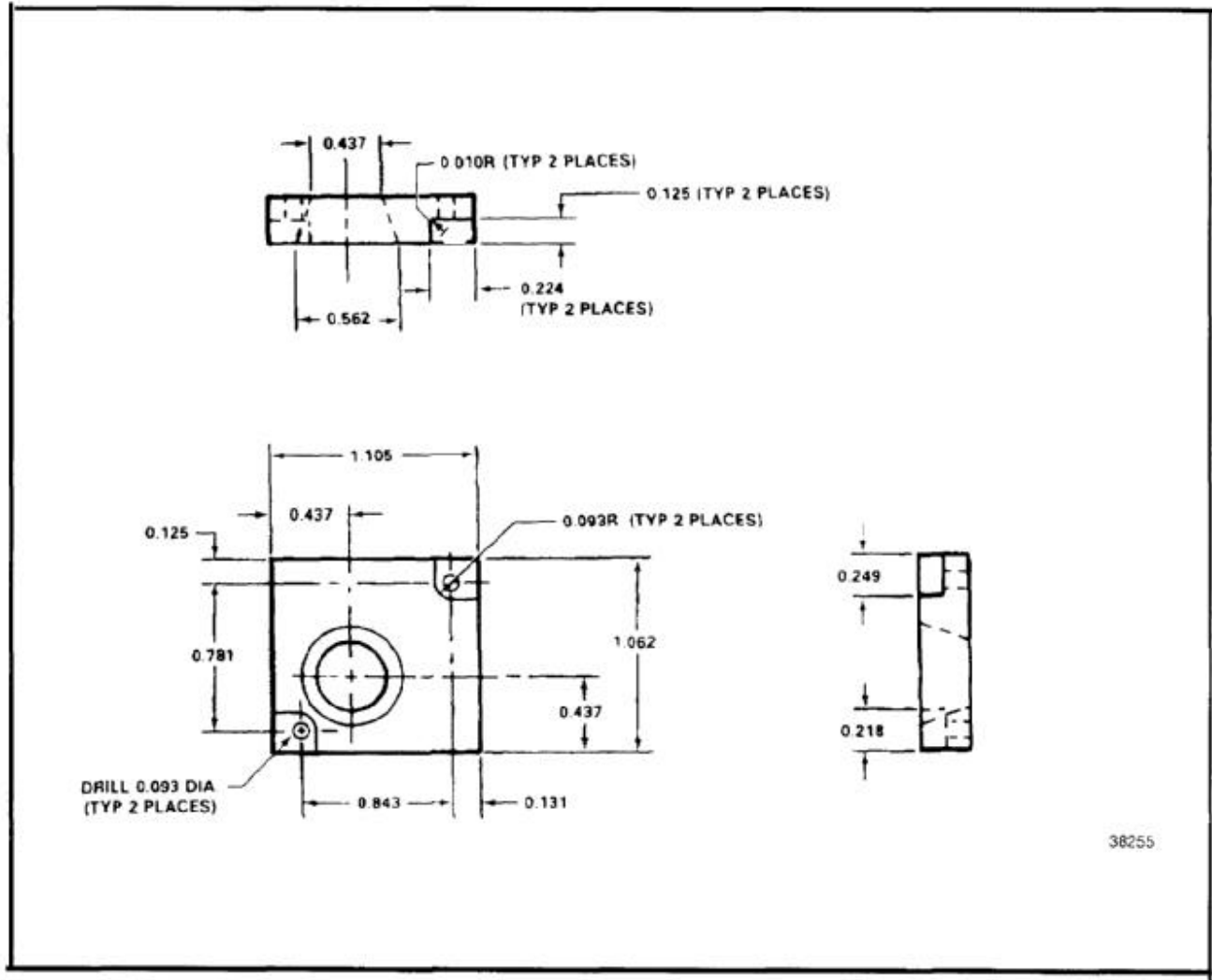

END OF TASK

NOTES:

1. FABRICATE FROM SUITABLE SIZE DRIFT.
2. DIMENSIONS IN INCHES.

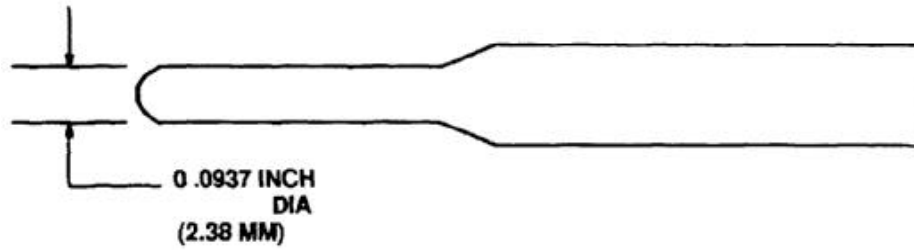

END OF TASK

E-390

NOTES:

1. FABRICATE FROM ALUMINUM ALLOY CLAD SHEET 2024-T3 PER QQ-A-250/5.
2. STOCK SIZE 0.032 X 3.625 X 4.0.
3. ALL DIMENSIONS IN INCHES.
4. FINISH AS REQUIRED.

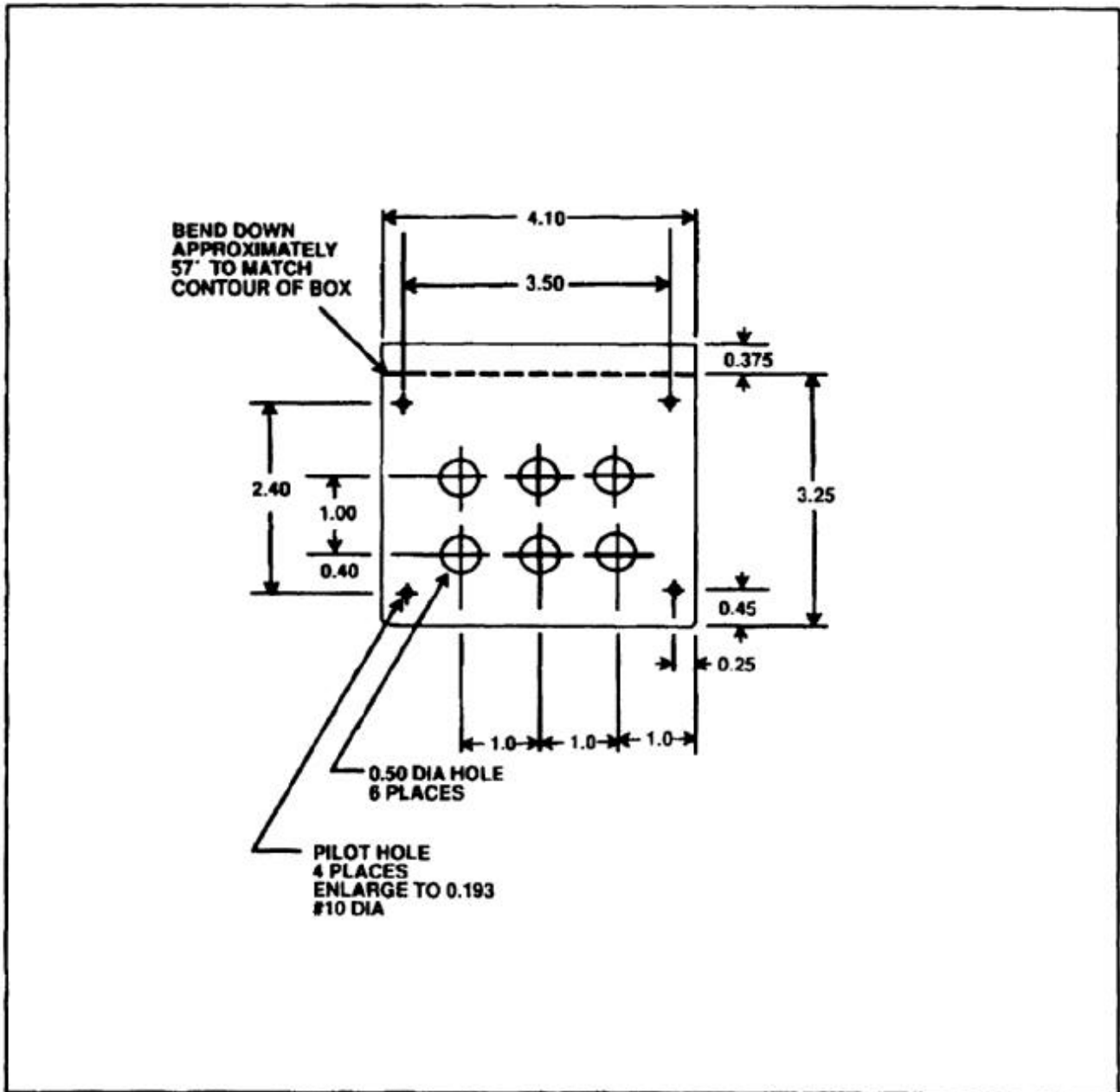

NOTES:

1. FABRICATE FROM ALUMINUM ALLOY CLAD SHEET 2024-T3 PER QQ-A-250/5.
2. STOCK SIZE 0.032 X 3.625 X 4.0.
3. ALL DIMENSIONS IN INCHES.
4. FINISH AS REQUIRED.

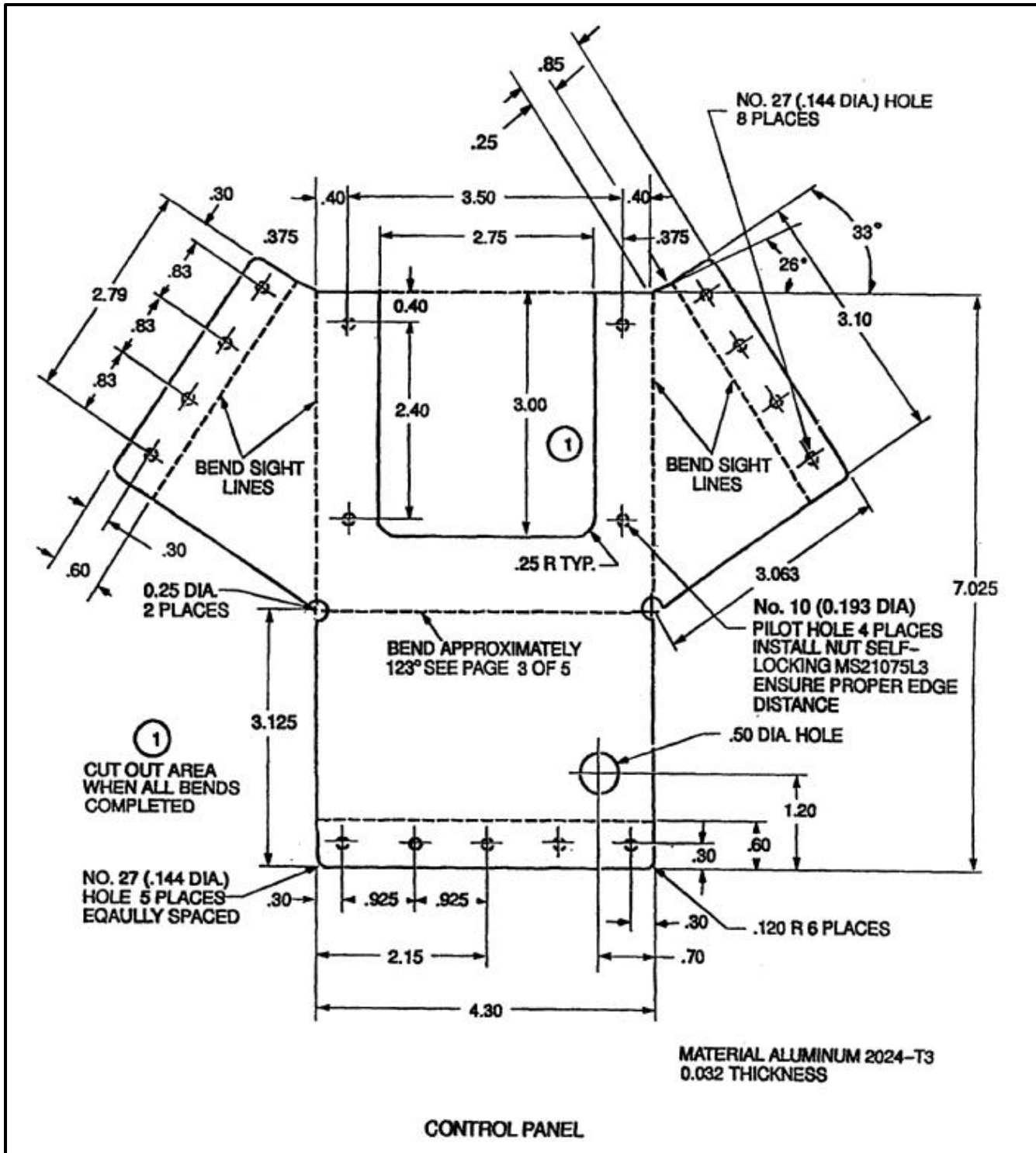

NOTES:

1. FABRICATE FROM ALUMINUM ALLOY CLAD SHEET 2024-T3 PER QQ-A-250/5.
2. STOCK SIZE 0.032 X 3.625 X 4.0.
3. ALL DIMENSIONS IN INCHES.
4. FINISH AS REQUIRED.

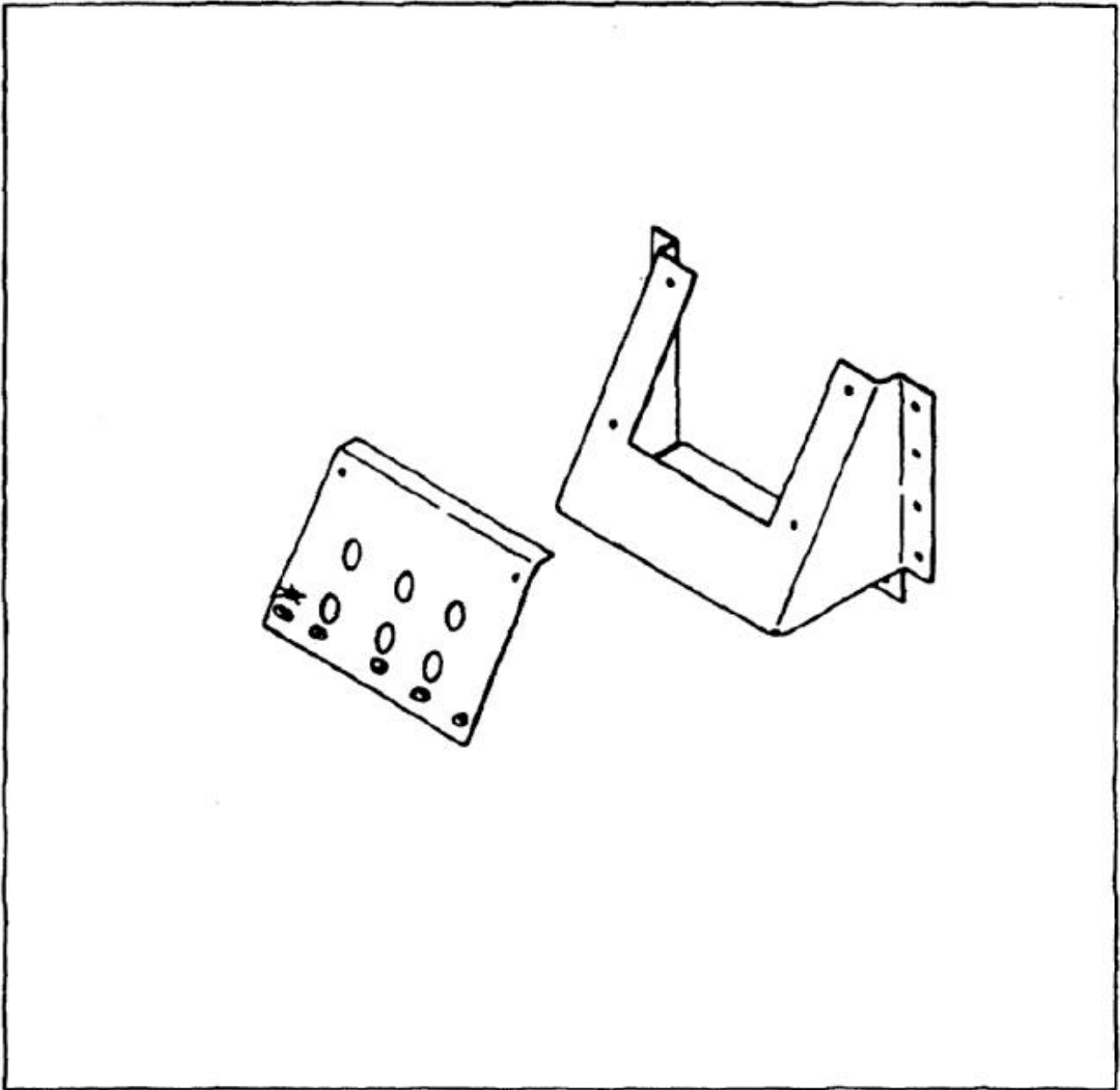

END OF TASK

NOTES:

1. FABRICATE FROM ALUMINUM ALLOY CLAD SHEET 2024-T3 PER QQ-A-250/5.
2. STOCK SIZE 0.50.
3. ALL DIMENSIONS IN INCHES.
4. FINISH AS REQUIRED.

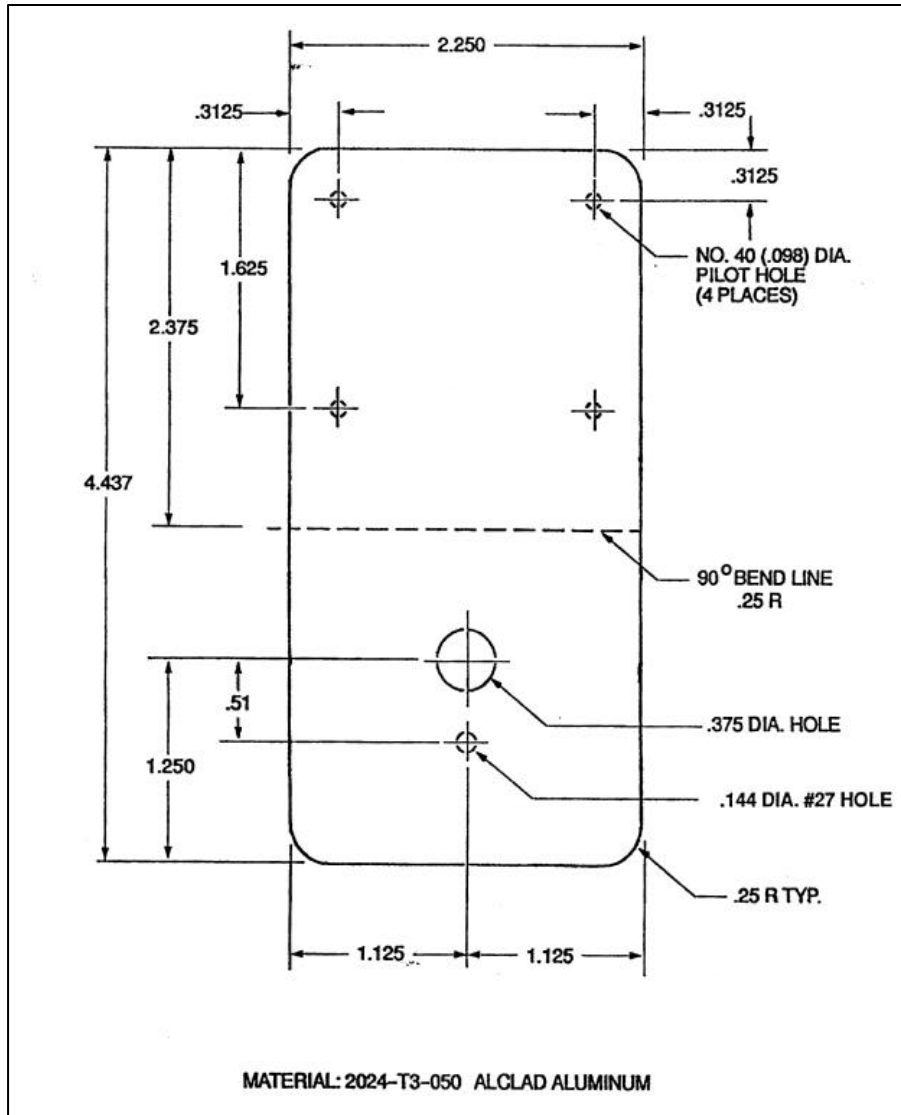

END OF TASK

E-315 DOUBLER, CARGO HOOK LIGHT

E-315

NOTES:

1. FABRICATE FROM ALUMINUM ALLOY CLAD SHEET 2024-T3 PER QQ-A-250/5.
2. STOCK SIZE 0.50.
3. ALL DIMENSIONS IN INCHES.
4. FINISH AS REQUIRED.

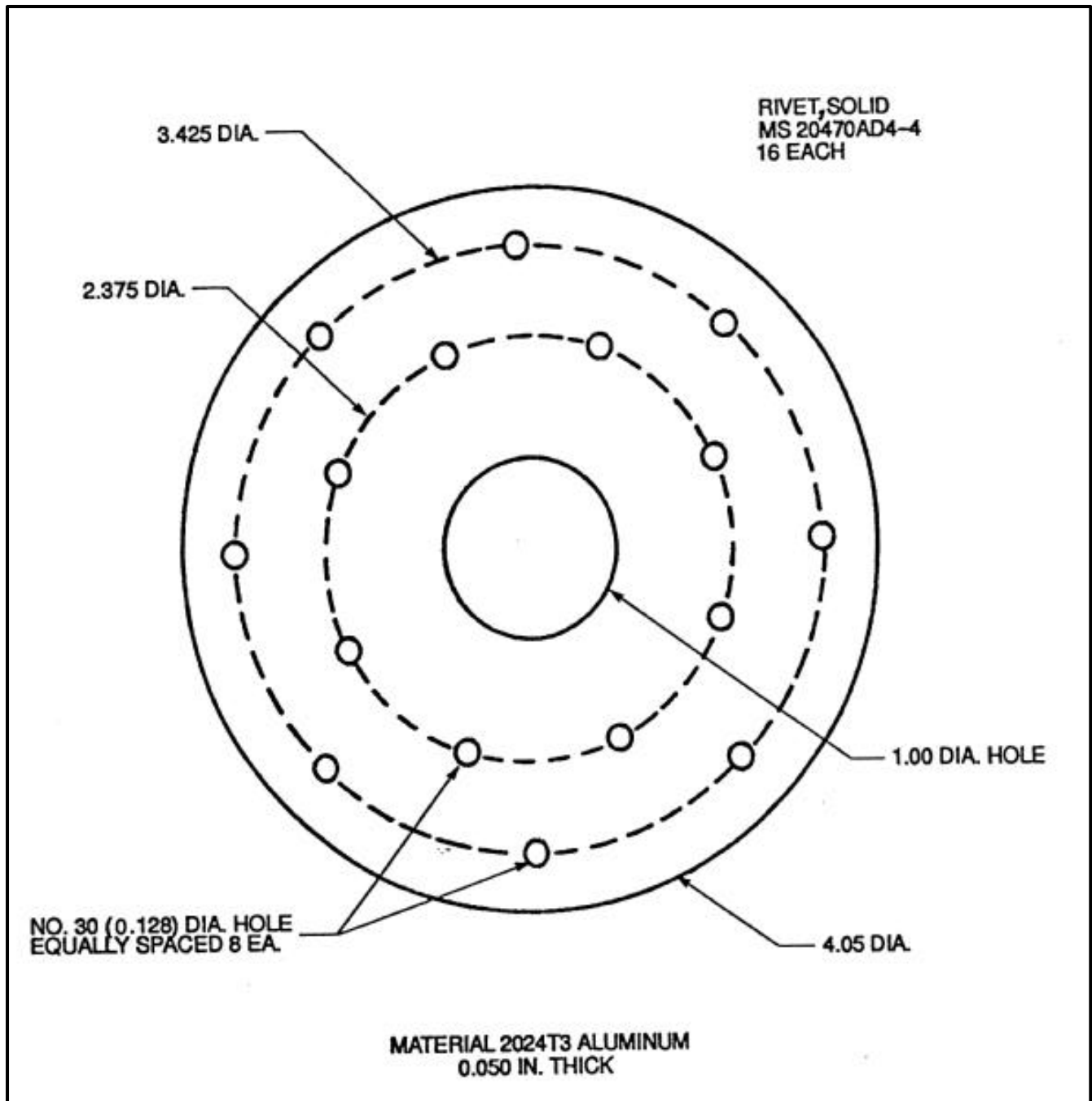

END OF TASK

E-395

NOTES:

1. FABRICATE ITEMS 1 AND 2 FROM .040-INCH THICK, TYPE 301, 1/4 HARD STAINLESS STEEL.
2. FABRICATE ITEM 3 FROM .063-IN TYPE 301, 1/4 HARD STAINLESS STEEL.
3. ALL DIMENSIONS IN INCHES.
4. USE NSN 5340-01-244-4124 OR NSN 5240-01-028-0086 FOR LATCH ASSY.
5. FINISH AS REQUIRED.

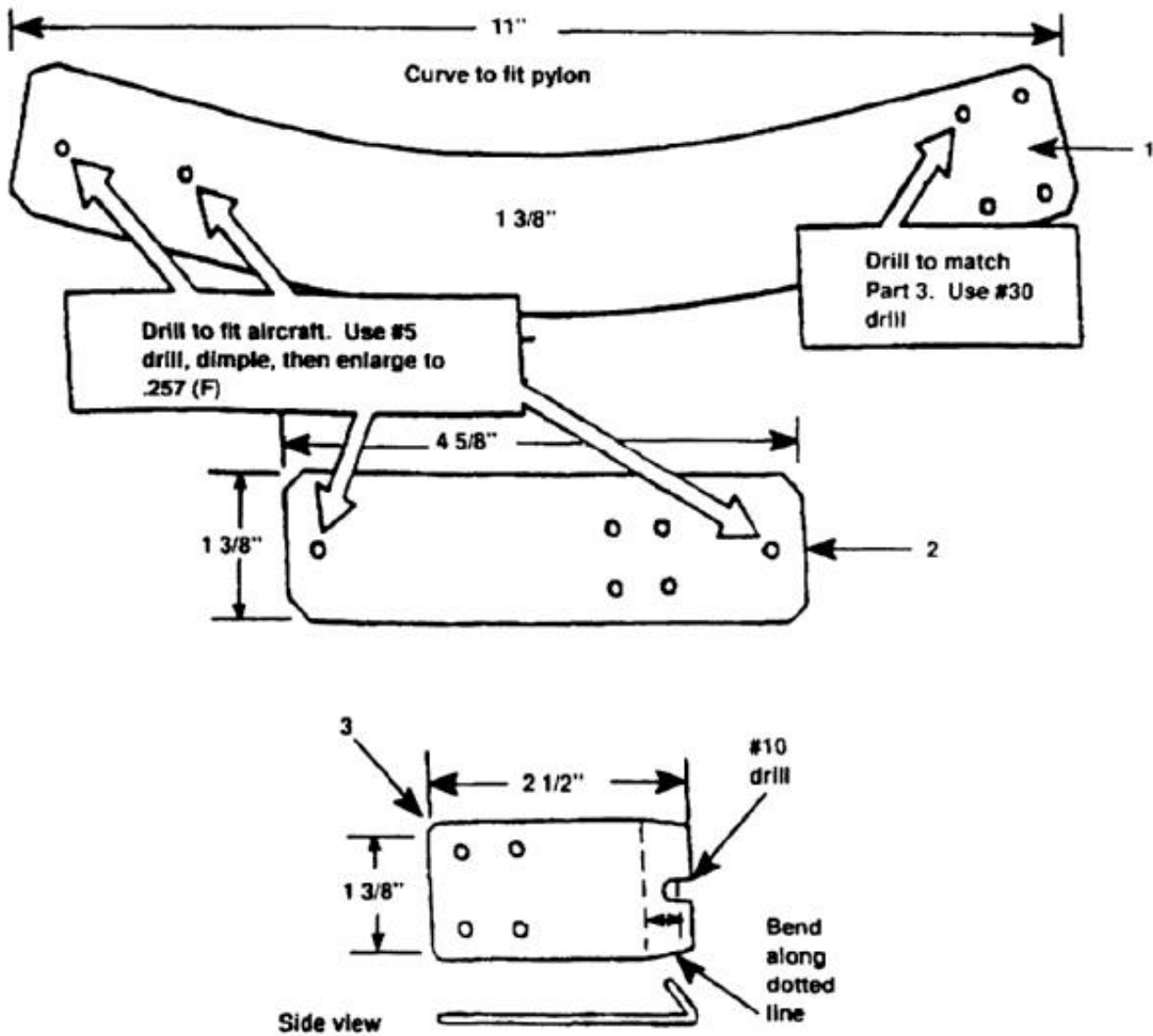

END OF TASK

1.

NOTES:

FABRICATE FROM:

SWITCH BOX (SIZE OPTIONAL)	0.032, 2024-T3 CLAD AL	A/R
SWITCH (SPDT) (S1)	MS24523-21	QTY 1
SWITCH (DPTT) (S2)	MS27407-4	QTY 1
CONNECTOR	MS3476W10-6S	QTY 1
BACKSHELL	BACC10JP10A	QTY 1
WIRE	20 AWG (STRANDED)	A/R
TERMINALS (POWER SUPPLY)	TYPE MATEABLE WITH AVAILABLE POWER SUPPLY	QTY 2
LAMP HOLDER	25F1291	QTY 2
PANEL LIGHT	SHORT CYL. 28VDC 25F1434 (RED)	QTY 2

2. HOLES FOR SWITCHES AND THEIR ORIENTATION TAB OR KEY MUST BE PROPERLY INSTALLED IN FACE OF BOX TO ASSURE PROPER ORIENTATION OF SWITCHES TO MARKINGS AS SHOWN.

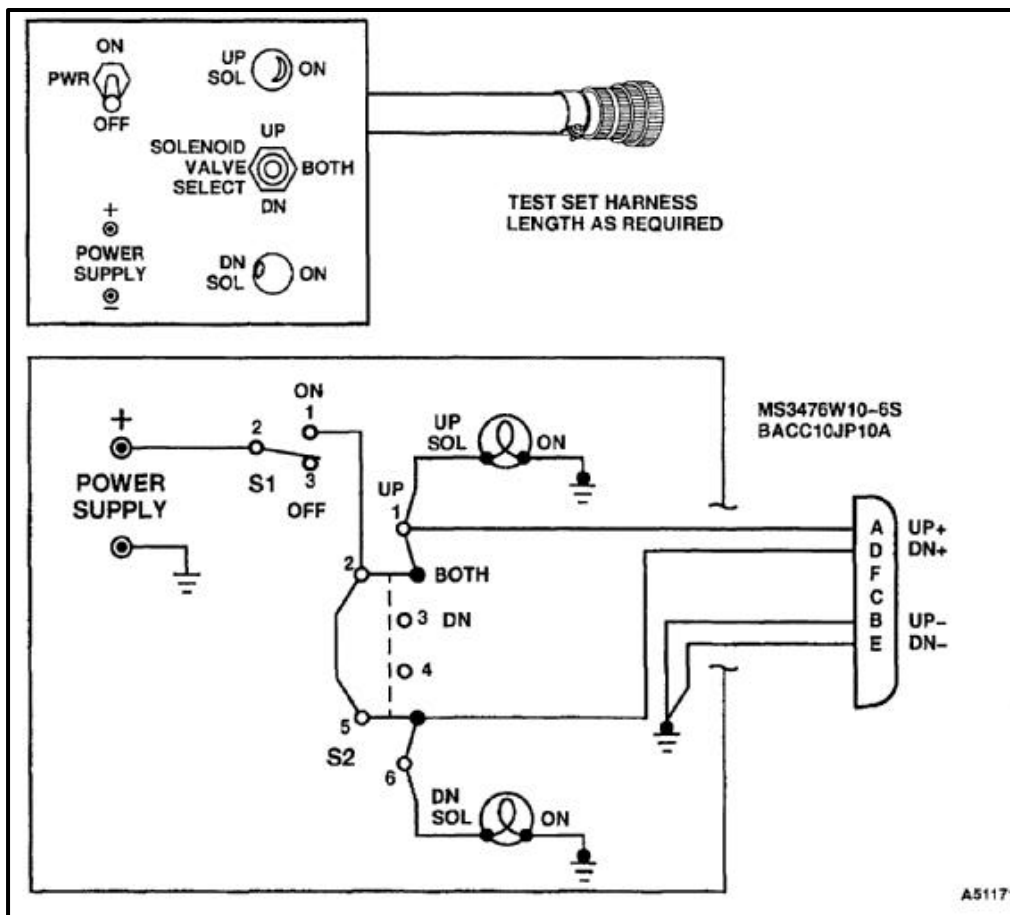

END OF TASK

NOTES:

1. FABRICATE FROM 72.0 INCH LENGTH OF AEROQUIP AE701-6 HOSE.
2. INSTALL AEROQUIP 816-6 FITTING ON EACH END OF HOSE.

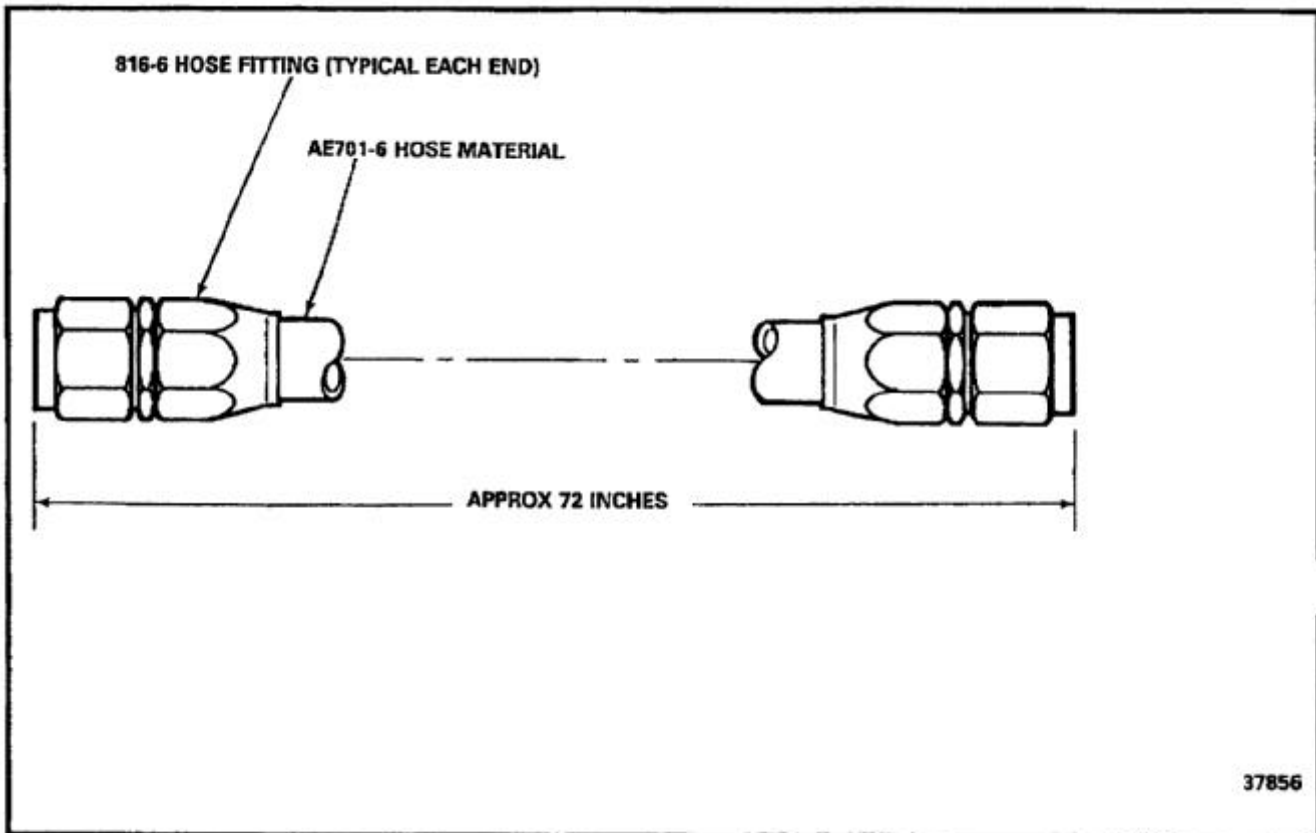

END OF TASK

NOTES:

1. MOUNT A SUITABLE TERMINAL BOARD IN AN ENCLOSURE.
2. USE 3 OR 4 FEET OF SHIELDED DUAL TWISTED PAIR WIRE BETWEEN CONNECTOR (D38999/24WA35SN) PINS AND TERMINAL BOARD.
3. INSTALL A 10K OHM RESISTOR BETWEEN STUDS 3 AND 4 OF THE TERMINAL BOARD (LVDT LOAD).
4. CONNECT A 10 FOOT LENGTH OF 20 GAUGE (OR LARGER) WIRE TO STUD 1 OF THE TERMINAL BOARD AND CRIMP A SPADE LUG TO THE FREE END OF THE WIRE.
5. CONNECT A 10 FOOT LENGTH OF 20 GAUGE (OR LARGER) WIRE TO STUD 2 OF THE TERMINAL BOARD AND CRIMP A GROUND (ALLIGATOR) CLIP TO THE FREE END OF THE WIRE.
6. ATTACH JUMPER BETWEEN STUDS 2 AND 6 OF THE TERMINAL BOARD.
7. MOUNT FOUR INPUT TEST JACKS ON THE FRONT OF THE ENCLOSURE. CONNECT THE JACKS TO THE TERMINAL BOARD PER THE ILLUSTRATION.
8. LABEL THE JACKS INPUT AND OUTPUT PER THE ILLUSTRATION.

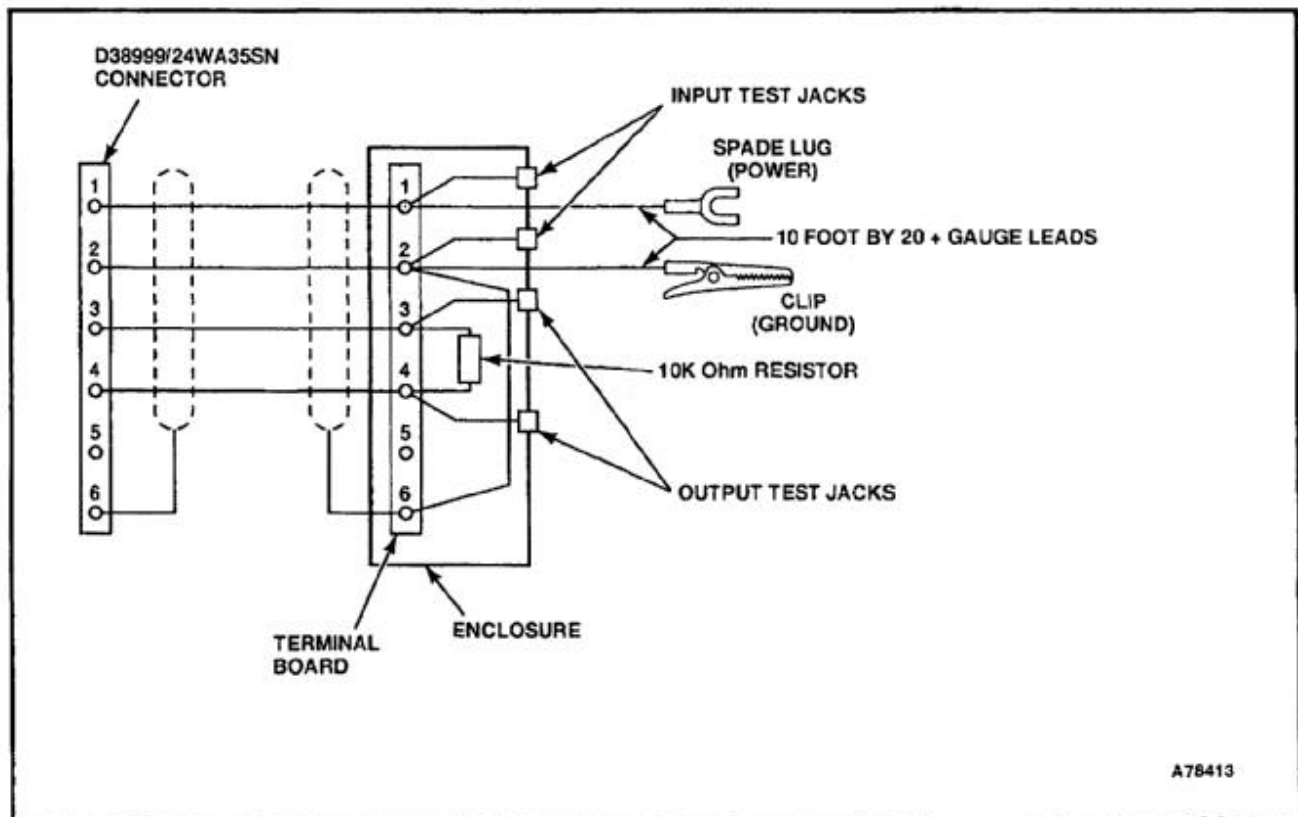

END OF TASK

NOTES:

1. DIAPHRAGM REPLACEMENT TOOL CONSISTS OF SK33086-1 HANDLE AND SK 33086-2 DIAPHRAGM COMPRESSOR.
2. BREAK ALL SHARP EDGES AND DEBURR.
3. TOLERANCES:
 $\pm .X .1$
 $.X \pm .03$
 $\pm .XXX .005$
4. ALL DIMENSIONS IN INCHES.
5. DIAPHRAGM COMPRESSOR TOOL SK33086-2 IS FABRICATED FROM STL 1040 RD BAR.
6. HANDLE SK33086-1 IS FABRICATED FROM ALUM 6061 TUBE OF 2.00 OD X 1.00 ID.

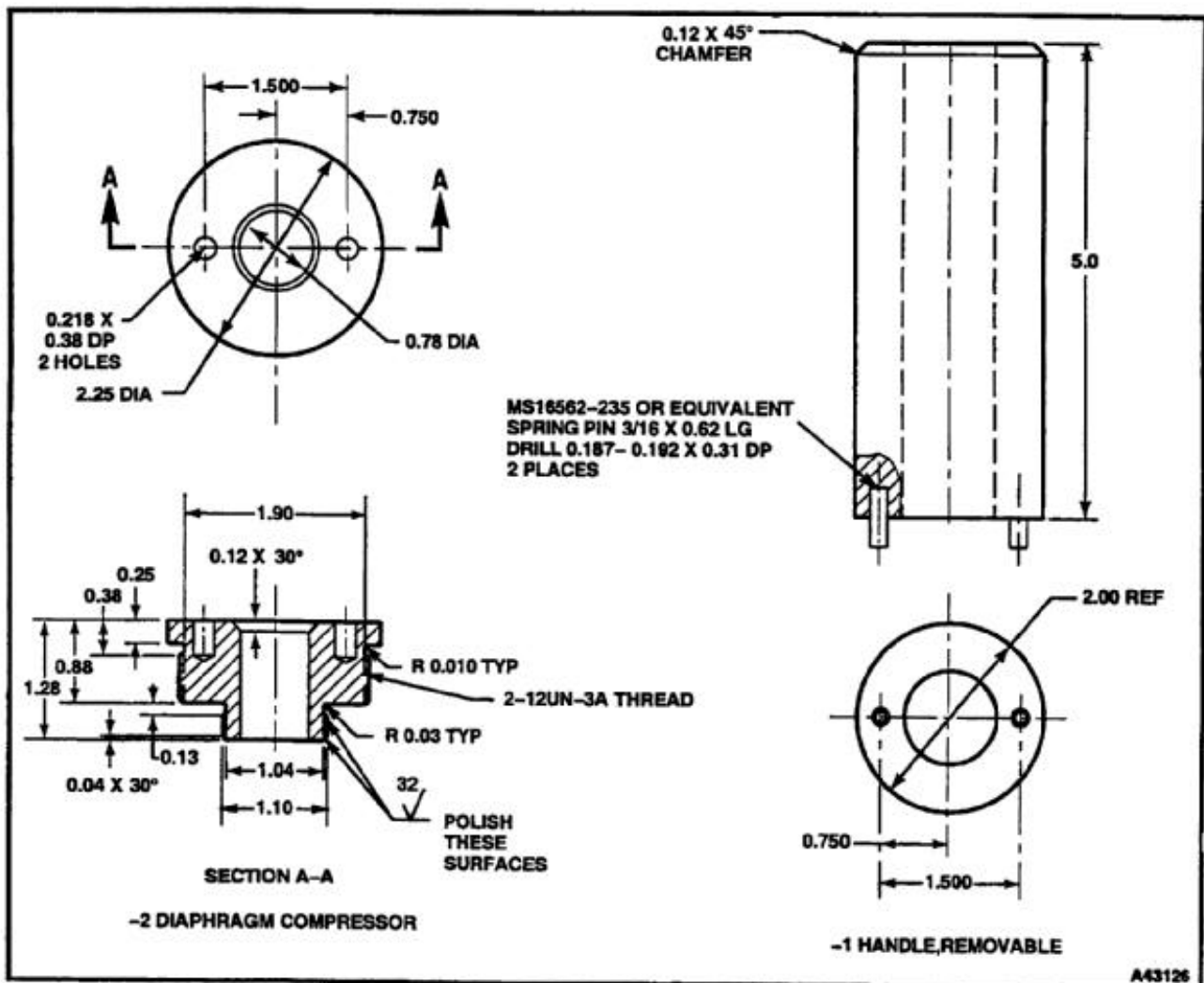

END OF TASK

NOTES:

1. FABRICATE FROM MS20001P12,
NSN 5340-00-664-8138.
2. THE -09 (LH) IS THE OPPOSITE OF THE -10
(RH).
3. USE ORIGINAL PART TO DETERMINE HOLE
LOCATIONS AND SHAPE OF HINGE.
4. FINISH AS REQUIRED.

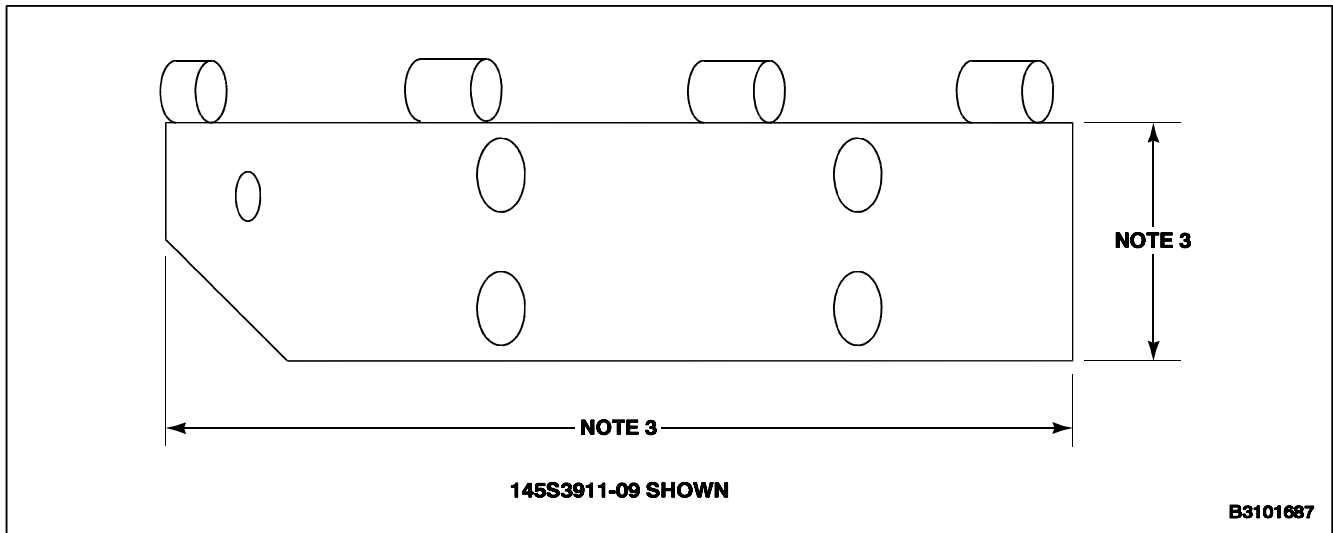

END OF TASK

NOTES:

1. FABRICATE FROM ALUMINUM ALLOY 2024-T3 BARE.
2. ALL DIMENSIONS ARE IN INCHES.
3. STOCK SIZE 0.032 X 1.3 X 3.6.
4. FINISH AS REQUIRED.

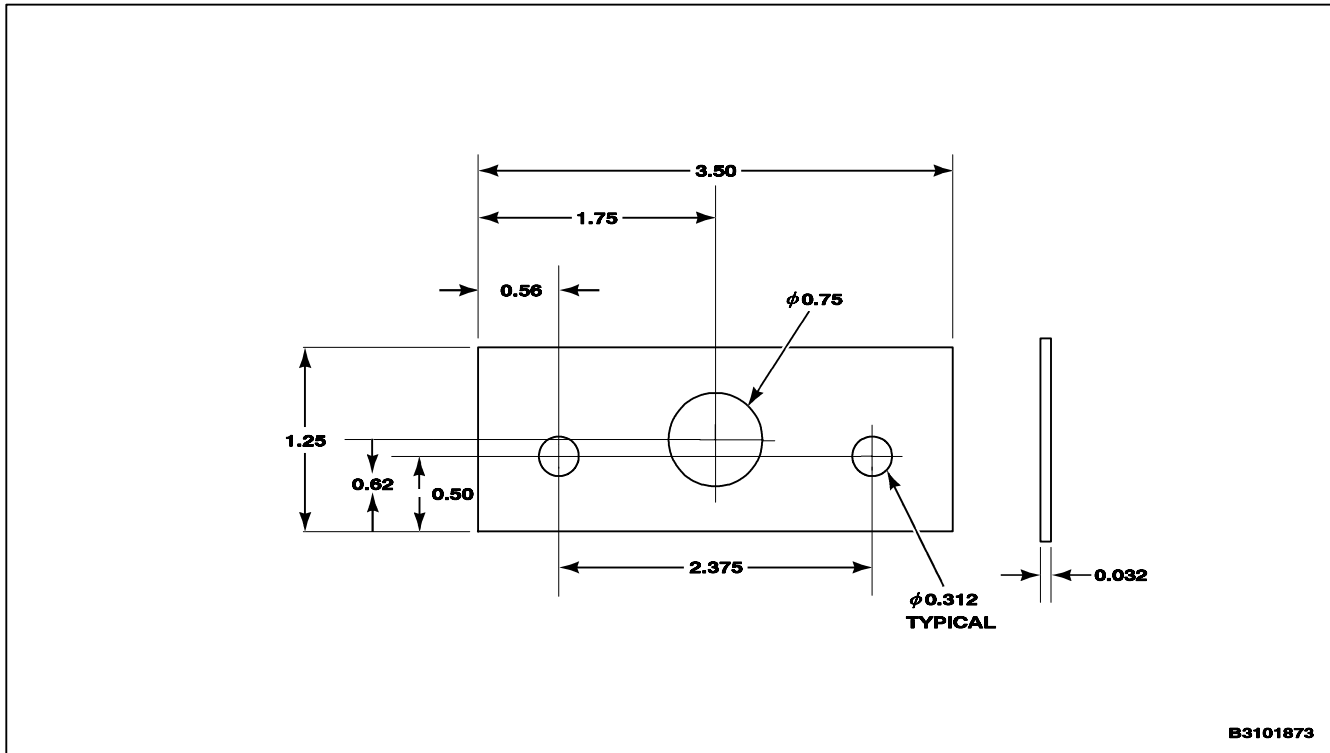

B3101873

END OF TASK

E-402 Change 1

APPENDIX F WIRING DIAGRAMS

(See TM 55-1520-240-T)

APPENDIX G
WEIGHT AND BALANCE

SECTION I

GENERAL INFORMATION

G-1. WEIGHT AND BALANCE.

- a. This appendix contains procedures required for intermediate maintenance personnel to perform their phase of the weight and balance control. The procedures are specifically applicable to the CH-47D and include the use of certain forms in the DD 365 series. For general weight and balance information, refer to TM 55-1500-342-23. It is not the intent of this appendix to duplicate information contained in TM 55-1500-342-23.
- b. The weight and balance data provides the service activities with a standard system of intermediate maintenance weight and balance control. It contains brief instructive information to be used with the forms and charts which provide for continuous control of weight and balance of the aircraft. The data to be inserted on the charts and forms are applicable only to the individual aircraft, the serial number of which appears on the various forms and charts. These data are to remain with the aircraft in accordance with existing directives. The charts and forms referred to herein may differ in nomenclature and arrangement from those shown in previously published copies, since these charts are revised from time to time; however, the general principle of use will not change.

G-2. Responsibility. The aircraft manufacturer inserts all aircraft identifying data on the various charts, including one sample weight and balance clearance DD Form 365F, if applicable, at time of delivery. This record constitutes the basic weight and balance data of the aircraft at delivery. It is the maintenance officer's responsibility to monitor the technician who maintains the weight and balance data records. These data shall be maintained in a permanent binder for each aircraft. The binder shall reflect the model designation and the aircraft serial number. All DD Form 365 series forms, charts, and any other pertinent weight and balance data shall be maintained therein. All subsequent changes in weight and balance are compiled by the weight and balance technician in accordance with instructions contained herein.

G-3. Weight definition. Tare is the weight of equipment necessary for weighing the aircraft (chocks, blocks, slings, jacks, etc.) which is included in the scale reading (or reactions) but is not a part of the aircraft weight. Reference is made to TM 55-1500-342-23 for weight and balance definitions.

SECTION II

USE OF FORMS AND CHARTS

G-4. Instructions for use of the forms and charts. There are two parts to the weight and balance problem. First, one must have correct information as to the basic weight and moment. Second, gross weight and balance must be maintained within weight and center of gravity limits with the addition of load. The first part is controlled by basic weight check list and basic weight and balance record after the basic weight and balance have been determined by weighing the aircraft. The second part is carried out on form F with the aid of a balance computer or loading data charts or graphs.

NOTE

The DD Form 365-series forms shall have no security classification until filled in. The forms, when filled in, shall take on the security classification of the aircraft for which they are used.

G-5. Forms. The standard system of intermediate maintenance weight and balance control requires the use of several different forms and shall be presented as samples in this appendix. They are identified as follows:

- a. Record of Weight and Balance Personnel, DD Form 365 (Figure G-1).
- b. Basic Weight Check List, DD Form 365-1 (Figure G-2).
- c. Airplane Weighing Record, DD Form 365-2 (Figure G-3).
- d. Basic Weight and Balance Record, DD Form 365-3 (Figure G-4).
- e. Loading Data, Charts and Graphs. Chart E (Figure G-5).
- f. Weight and Balance Clearance Form F, DD Form 365-4 (Figure G-6).

G-6. Record of Weight and Balance Personnel, DD Form 365 (Figure G-1). Listed at the top of this form are the aircraft designation and serial numbers. The form provides a continuous record of the name and grade (civilian or military) of weight and balance personnel responsible for the records, the station, the date assigned, and the date relieved. All entries shall be complete and legible.

G-7. Basic Weight Checklist, DD Form 365-1 (Figure G-2). The basic weight checklist is a tabulation of all operating equipment that is or may be installed and for which provision for fixed stowage has been made in a definite location in the aircraft. It gives the weight, arm, and moment/constant of the individual items for use in correcting the basic weight and moment on DD Form 365-3 as changes are made in this equipment. When check marks are entered in the IN AIRCRAFT column, it serves as the inventory of equipment included in the basic weight and moment/constant.

- a. Inventories shall be made periodically, and when:
 - (1) The aircraft undergoes modification, major overhaul, or repair.
 - (2) The aircraft is received at a new base.
 - (3) Changes in equipment are made for a different type of operation or mission.
 - (4) The aircraft is reweighed.
 - (5) The pilot reports unsatisfactory flight characteristics (tail or nose heaviness).
- b. The manufacturer of the aircraft placed check marks in the IN AIRCRAFT column to identify the items of equipment in the aircraft for the delivery condition. This delivery inventory shows equipment included in the initial basic weight entry on DD Form 365-3.
- c. Subsequent checklist inventories shall be carried as follows:

- (1) Inspect aircraft for equipment actually installed, placing check marks in the next unused IN AIRCRAFT column. A check in the column headed IN AIRCRAFT indicates the presence of the item in the aircraft on the date at the head of the column, and a zero (0) indicates its absence. Items should not be checked unless they are installed, and items marked zero are not to be included in the basic weight and balance tabulated on DD Form 365-3 for the corresponding date. During this inventory, note whether any new items of equipment have been installed, and if so, enter item number and name or description, together with other data required through column moment/constant, including date in parentheses following description.

- (2) Compare this inventory with that under last CHECK heading, noting any changes in items of equipment installed in aircraft. Refer to DD Form 365-3 to ascertain whether necessary weight and moment corrections have been made. If so, place check marks opposite such items in CHART C ENTRY column on the DD Form 365-1. If not, correct basic weight and moment/constant data on DD Form 365-3 and then enter CHART C ENTRY column check marks.
- (3) Check marks are made only at the time of a complete inventory. Never change check marks or add new ones under a previously accomplished check heading. Use next CHECK column. When an inventory is included as part of a weighing, the procedures outlined in the preceding paragraph should not be omitted since this correction makes possible the comparison of calculated and actual weight figures. Check marks in CHART C ENTRY column indicate only a calculated change in the basic chart C figures.
- (4) Ensure the same date is entered over CHECK heading on DD Form 365-1 and in date column on DD Form 365-3 for corresponding corrected basic weight and moment/constant.

G-8. Airplane Weighing Record, DD Form 365-2 (Figure G-3). Fill out DD Form 365-2 as follows:

- a. Fill in identifying data and enter actual scale readings in first columns.

NOTE

The example weighing forms, provided in Figure G-3 have been modified specifically for use with CH-47D helicopters. A reproducible modified DD Form 365-2 is also provided in Figure G-3. This form is usable for 3 or 4 point weighing.

- b. Subtract tare, if any, from scale readings to obtain net weight.



If the helicopter is to be weighed using the 3-point method, the gross weight must be determined by using the chart in task 1-30. If the 4-point method is used, the helicopter is restricted to a maximum gross weight of **33,000 pounds**.

NOTE

Actual measurements are not necessary when the helicopter is weighed using either the forward fuselage jack point or the forward landing gear scissor jack pads and the aft fuselage jack points.

- c. When weighing on 3 points, the forward fuselage jack pad is used in lieu of the 2 jack pads located on the forward landing gear. The forward fuselage jack pad is a jig point located at fuselage sta. 96.0 designated as I on weighing form (Figure G-3, sample DD Form 365-2). The 2 aft fuselage jack points as described in the 4 point weighing procedure are used in conjunction with the forward jack pad. They are also jig points and are located at fuselage sta. 484.5. They are designated as J on weighing form Figure G-3. When weighing on 4 points, the jack pads on the landing gear scissors LH and RH are used for the forward reactions. They are located at fuselage sta. 251.6 and designated as F on weighing form. The two aft fuselage jack points are jig points and are located at fuselage sta. 484.5 and designated as J on the weighing form. Moments are taken about the reference datum.
- d. Add net weights and moments of forward and aft reaction.
- e. Divide total moment by total net weight to obtain as weighed CG position in inches from reference datum (H).
- f. Transfer TOTAL (As Weighed) weight, arm, and moment to back of weighing form.

ROTORCRAFT WEIGHING RECORD					
DATE WEIGHED		MODEL		SERIAL NUMBER	
PLACE WEIGHED			WEIGHING PERSONNEL		
REACTION (WHEELS, JACKPOINTS, ETC.)	SCALE READING	TARE	NET WEIGHT	ARM	MOMENT
LEFT FWD.	8630	— 0 —	8630		
RIGHT FWD.	—	—	—		
SUBTOTAL (BOTH FWD.) OR FWD. ONLY	8630		8630	$\frac{F}{OR}$ 96.0	828480
LEFT AFT	6290	— 0 —	6290		
RIGHT AFT	8490	— 0 —	8490		
SUBTOTAL (BOTH AFT)	14780	— 0 —	14780	$\frac{J}{OR}$ J 484.5	7160910
TOTAL (AS WEIGHED)	23410	— 0 —	23410	341.3	7989390

MEASUREMENTS

B = — THE DISTANCE FROM THE JIG POINT TO THE CENTER LINE OF THE AFT REACTIONS. OBTAINED BY MEASUREMENT.

I = 96.0 THE DISTANCE FROM THE REFERENCE DATUM TO THE JIG POINT ALSO THE FORWARD FUSELAGE JACKPOINT (1). FROM WHICH A PLUMB BOB CAN BE DROPPED TO THE GROUND. OBTAIN FROM THE ROTORCRAFT DIAGRAM IN CHART E.

E = — 1/2 THE DISTANCE FROM THE REFERENCE DATUM TO THE CENTER LINE OF THE AFT REACTIONS. $E = I + B$

D = — THE WHEEL BASE (OR THE DISTANCE BETWEEN FORE AND AFT REACTIONS.) OBTAINED BY MEASUREMENT.

F = — 1/2 THE DISTANCE FROM THE REFERENCE DATUM TO THE CENTER LINE OF THE FWD. REACTIONS. $F = E - D$

J = 484.5 THE DISTANCE FROM THE REFERENCE DATUM TO THE AFT FUSELAGE JACKPOINTS (2) OBTAIN FROM THE ROTORCRAFT DIAGRAM IN CHART E.

EXAMPLE
Three point weighing

DIAGRAM FOR MEASURING ROTORCRAFT TO DETERMINE ARM OF SUPPORT POINTS

1/CHECK DIMENSIONS E AND F AGAINST DIMENSIONS LISTED ON CHART E.

DD FORM 365-2 (MODIFIED)

14190

Figure G-3. DD Form 365-2 (Sheet 1 of 6)

DESCRIPTION		NET WEIGHT		ARM	MOMENT	INDEX OR MOM/1000	
TOTAL (AS WEIGHED) (FROM FRONT SIDE)		23410		(341.3)	7989390		
OIL IN AIRPLANE		—		—	—		
TOTAL OF ITEMS WEIGHED BUT NOT PART OF BASIC WEIGHT (FROM COLUMN I BELOW)		10		(251.6)	2516		
TOTAL OF BASIC WEIGHT ITEMS NOT IN AIRCRAFT WHEN WEIGHED (FROM COLUMN II BELOW)							
BASIC AIRCRAFT (POST TO CHART C)		23400		(341.3)	7986874	7986.9	
COLUMN I				COLUMN II			
ITEMS WEIGHED BUT NOT PART OF BASIC WEIGHT	WEIGHT	ARM	MOMENT	BASIC WEIGHT ITEMS NOT IN AIRCRAFT WHEN WEIGHED	WEIGHT	ARM	MOMENT
CHAINS, FWD STRUTS	10	251.6	2516				
TOTAL	10	251.6	2516	TOTAL			
REACTIONS USED				TYPE SCALE COX & STEVENS (REVERE CORP) SERIAL NUMBER S/N 4391 CALIBRATION DATE 11/17/87 CALIBRATED ACCURACY 11/18/88			
FORWARD REACTION - FWD FUSELAGE JACKING PAD							
AFT REACTION - AFT LANDING GEAR JACKING PAD (2)							
REMARKS							
1. AIRCRAFT WEIGHED IN A LEVEL ATTITUDE IN A CLOSED HANGAR.							
2. BASIC WEIGHT INCLUDES FULL ENGINE OIL, TRAPPED AND UNUSABLE FUEL.							
<p>EXAMPLE</p> <p>Three point weighing</p>							
ENTER CONSTANT HERE							

14191

Figure G-3. DD Form 365-2 (Reverse) (Sheet 2 of 6)

ROTORCRAFT WEIGHING RECORD					
DATE WEIGHED		MODEL		SERIAL NUMBER	
PLACE WEIGHED			WEIGHING PERSONNEL		
REACTION (WHEELS, JACKPOINTS, ETC.)	SCALE READING	TARE	NET WEIGHT	ARM	MOMENT
LEFT FWD.	9582	-0-	9577		
RIGHT FWD.	9692	-0-	9687		
SUBTOTAL (BOTH FWD.) OR FWD. ONLY	19274	-0-	19274	F OR J 251.6	4849338
LEFT AFT	5411	-0-	5411		
RIGHT AFT	5456	-0-	5456		
SUBTOTAL (BOTH AFT)	10867	-0-	10867	E OR J 484.5	5265062
TOTAL (AS WEIGHED)	30,141		30,141	(335.6)	10114400

MEASUREMENTS

B - THE DISTANCE FROM THE JIG POINT, TO THE CENTER LINE OF THE AFT REACTIONS. OBTAINED BY MEASUREMENT.

I - THE DISTANCE FROM THE REFERENCE DATUM TO THE JIG POINT ALSO THE FORWARD FUSELAGE JACKPOINT (I). FROM WHICH A PLUMB BOB CAN BE DROPPED TO THE GROUND. OBTAIN FROM THE ROTORCRAFT DIAGRAM IN CHART E.

E - 1/2 THE DISTANCE FROM THE REFERENCE DATUM TO THE CENTER LINE OF THE AFT REACTIONS. $E = I + B$

D - THE WHEEL BASE (OR THE DISTANCE BETWEEN FORE AND AFT REACTIONS.) OBTAINED BY MEASUREMENT.

F - 251.6 1/2 THE DISTANCE FROM THE REFERENCE DATUM TO THE CENTER LINE OF THE FWD. REACTIONS. $F = E \cdot D$

J - 484.5 THE DISTANCE FROM THE REFERENCE DATUM TO THE AFT FUSELAGE JACKPOINTS (2) OBTAIN FROM THE ROTORCRAFT DIAGRAM IN CHART E.

EXAMPLE
Four point weighing

DIAGRAM FOR MEASURING ROTORCRAFT TO DETERMINE ARM OF SUPPORT POINTS

1/CHECK DIMENSIONS E AND F AGAINST DIMENSIONS LISTED ON CHART E

DD FORM 385-2 (MODIFIED)

14188

Figure G-3. DD Form 365-2 (Sheet 3 of 6)

ROTORCRAFT WEIGHING RECORD					
DATE WEIGHED		MODEL		SERIAL NUMBER	
PLACE WEIGHED			WEIGHING PERSONNEL		
REACTION (WHEELS, JACKPOINTS, ETC.)	SCALE READING	TARE	NET WEIGHT	ARM	MOMENT
LEFT FWD					
RIGHT FWD					
SUBTOTAL (BOTH FWD) OR FWD ONLY					
LEFT AFT					
RIGHT AFT					
SUBTOTAL (BOTH AFT)					
TOTAL (AS WEIGHED)					

MEASUREMENTS

B — THE DISTANCE FROM THE JIG POINT TO THE CENTER LINE OF THE AFT REACTIONS OBTAINED BY MEASUREMENT

I — THE DISTANCE FROM THE REFERENCE DATUM TO THE JIG POINT ALSO THE FORWARD FUSELAGE JACKPOINT (I) FROM WHICH A PLUMB BOB CAN BE DROPPED TO THE GROUND. OBTAIN FROM THE ROTORCRAFT DIAGRAM IN CHART E

E — 1/2 THE DISTANCE FROM THE REFERENCE DATUM TO THE CENTER LINE OF THE AFT REACTIONS $E = I + B$

D — THE WHEEL BASE (OR THE DISTANCE BETWEEN FORE AND AFT REACTIONS) OBTAINED BY MEASUREMENT

F — 1/2 THE DISTANCE FROM THE REFERENCE DATUM TO THE CENTER LINE OF THE FWD REACTIONS $F = E - D$

J — THE DISTANCE FROM THE REFERENCE DATUM TO THE AFT FUSELAGE JACKPOINTS (J) OBTAIN FROM THE ROTORCRAFT DIAGRAM IN CHART E

DIAGRAM FOR MEASURING ROTORCRAFT TO DETERMINE ARM OF SUPPORT POINTS

1) CHECK DIMENSIONS E AND F AGAINST DIMENSIONS LISTED ON CHART E

DD FORM 365-2 (MODIFIED)

14186

Figure G-3. DD Form 365-2 Weighing Record (Sheet 5 of 6)

- g. Subtract total weight and moment of items entered in column I. These items should not be checked on chart A as IN AIRCRAFT.
- h. Add total weight and total moment of items in column II. These items must be checked in chart A as IN AIRCRAFT to indicate their inclusion in the basic weight. If aircraft is weighed after overhaul with a completely dry fuel or oil system, include trapped fuel or oil in column II.
- i. Enter new basic weight and moment/constant on DD Form 365-3. All subsequent aircraft loadings will be based on the latest figures entered on DD Form 365-3.
- j. Fill in reactions and type scales used.
- k. Include under REMARKS, information as to attitude of aircraft when weighed, method of support, etc.

G-9. Basic Weight and Balance Record, DD Form 365-3 (Figure G-4). DD Form 365-3 is a continuous history of the basic weight, moment, and balance computer index resulting from structural and equipment changes in service. At all times the last weight, moment/constant, and index entry is considered the current weight and balance status of the basic aircraft. The basic index for the balance computer can be determined by means of the index scale or index formula on the computer.

- a. At time of delivery of a new aircraft, the manufacturer entered on this chart the basic weight, moment/constant, and index of the aircraft. The itemized list of the equipment included herein is shown and checked on chart A in the IN AIRCRAFT column.
- b. Make additions to or subtractions from basic weight and moment on DD Form 365-3 when:
 - (1) Equipment is added to or removed from the aircraft. If item is listed on DD Form 365-1, enter identical item number, description and applicable weight, arm, and moment data on DD Form 365-3. If item is not listed on DD Form 365-1, determine its actual weight and arm, and record this information on both DD Form 365-1 and DD Form 365-3.

NOTE

Do not enter check marks on DD Form 365-1 for these items until a complete inventory is made, but enter the date in parentheses following the description.

- (2) A complete inventory reveals equipment changes not previously recorded. Post equipment changes as noted above. Date newly calculated basic weight and moment to correspond with date entered at head of CHECK column on DD Form 365-1 identifying equipment content of new figures. It is also helpful to record the check column number which substantiates this new basic weight and moment.
 - (3) Structural changes are made in the aircraft. If structural changes are provisions for equipment, list them separately from equipment to be installed thereon.
 - (4) The aircraft is reweighed. Before weighing make a complete inventory and bring calculated DD Form 365-3 figures up to date. Enter new as weighed basic weight and moment from aircraft weighing record.
- c. Any changes or modifications which are caused by a specific order should carry a reference to the order number and date which authorizes the change.

NOTE

The date entered on DD Form 365-3 must be consistent with the delivery date or the date entered on the top of the CHECK column on DD Form 365-1 and with the date on the aircraft weighing record if used.

G-10. Loading data (Figure G-5). The loading data illustrations provide information necessary to work a loading problem for the aircraft. The balance computer, if furnished, accomplishes the same purpose and requires less computation. From the loading graphs or tables, weight and moment/constant are obtained for all variable load items and are added arithmetically to the current basic weight and moment/constant (from DD Form 365-3) to obtain the gross weight and moment. The center of gravity of the loaded aircraft is represented by the intersection of the gross weight and moment lines on the center of gravity graph or by a moment figure if tables are used. If the aircraft is loaded within the forward and aft center of gravity limits, the intersection will fall between the limiting center of gravity lines on the center of gravity graph, or if a table is used, the moment figure will fall numerically between the limiting moments. The effect of the center of gravity on the expenditures in flight of such items as fuel and expendable stores may be checked by subtracting the weights and moments of such items from the takeoff gross weight and moment and replotting on the center of gravity graph or by checking the new moment with the center of gravity table. This check should be made to determine whether or not the center of gravity will remain within limits during the entire flight.

NOTE

U.S. Army Special Mission Aircraft shall use DD Form 365-4 titled TRANSPORT.

G-11. Weight and Balance Clearance Form F, DD Form 365-4 (Figure G-6). Form F is the summary of the actual disposition of load in the aircraft. It records the balance status of the aircraft step by step. It serves as a work sheet on which the weight and balance technical records and calculations, and any corrections, must be made to insure that the aircraft will be within weight and center of gravity limits. It is necessary to accomplish Form F prior to flight whenever an aircraft is loaded in a manner for which no previous valid Form F is available. Form F is furnished in expendable pads, or as separate sheets, which can be replaced when exhausted. An original and a carbon copy are prepared for each loading. The original sheets, carrying the signature of responsibility, can be removed to serve as certificates of proper weight and balance as required by existing clearance directives. The carbon copy must remain in the aircraft for the duration of the flight. On a cross-country flight, this form aids the weight and balance technician at refueling bases and stopover stations. There are two versions of this form: TRANSPORT and TACTICAL. They were designed to provide for the respective loading arrangements of these two types of aircraft. It will be noted that the general use and fulfillment of either version is the same, although specific instructions for filling out each version are given in the -10 manual. The choice of which version to use in case of a tactical aircraft which is used to transport cargo items, or of a cargo ship which is armed for protection, is the responsibility of the weight and balance technicians at the takeoff base.

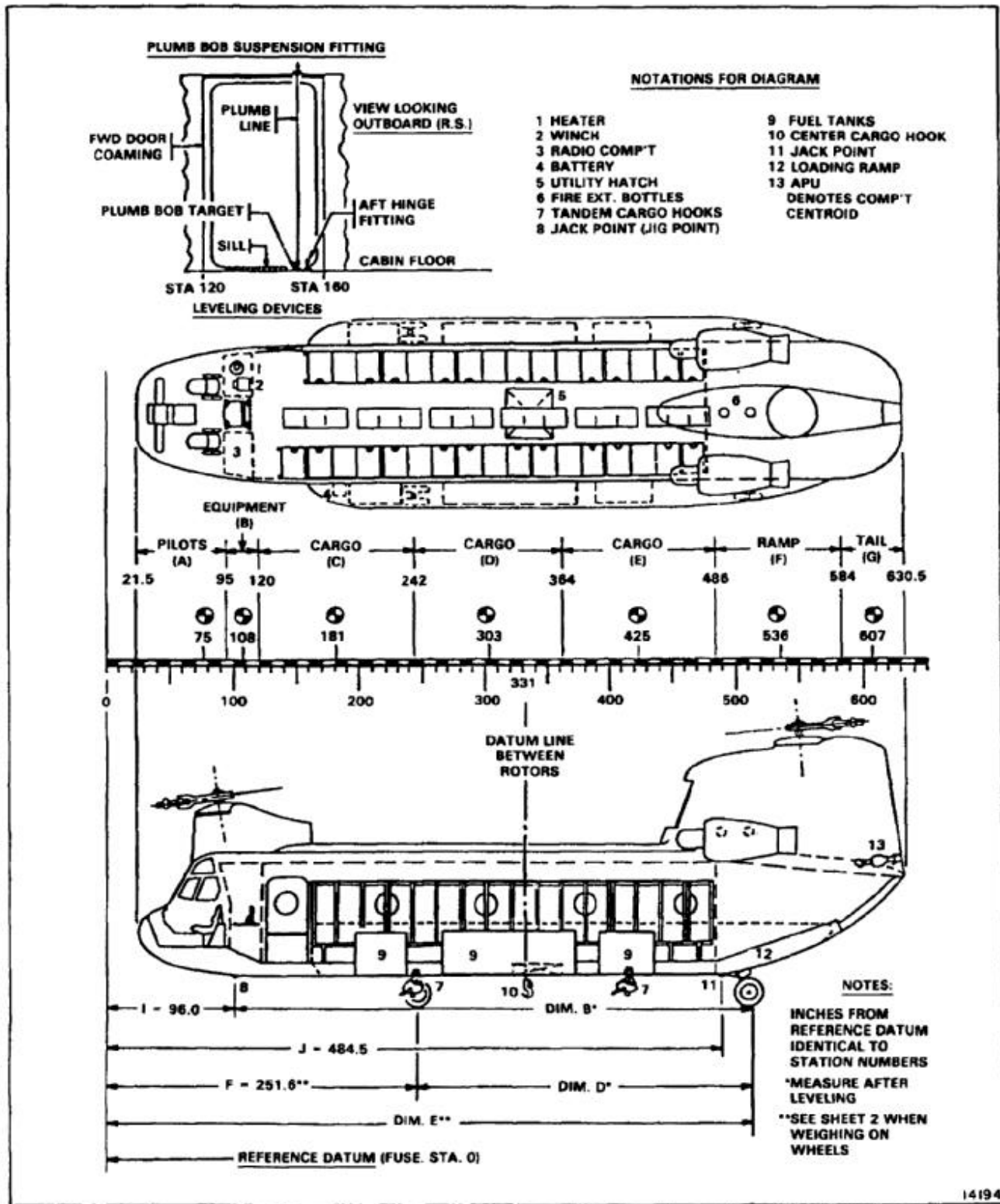
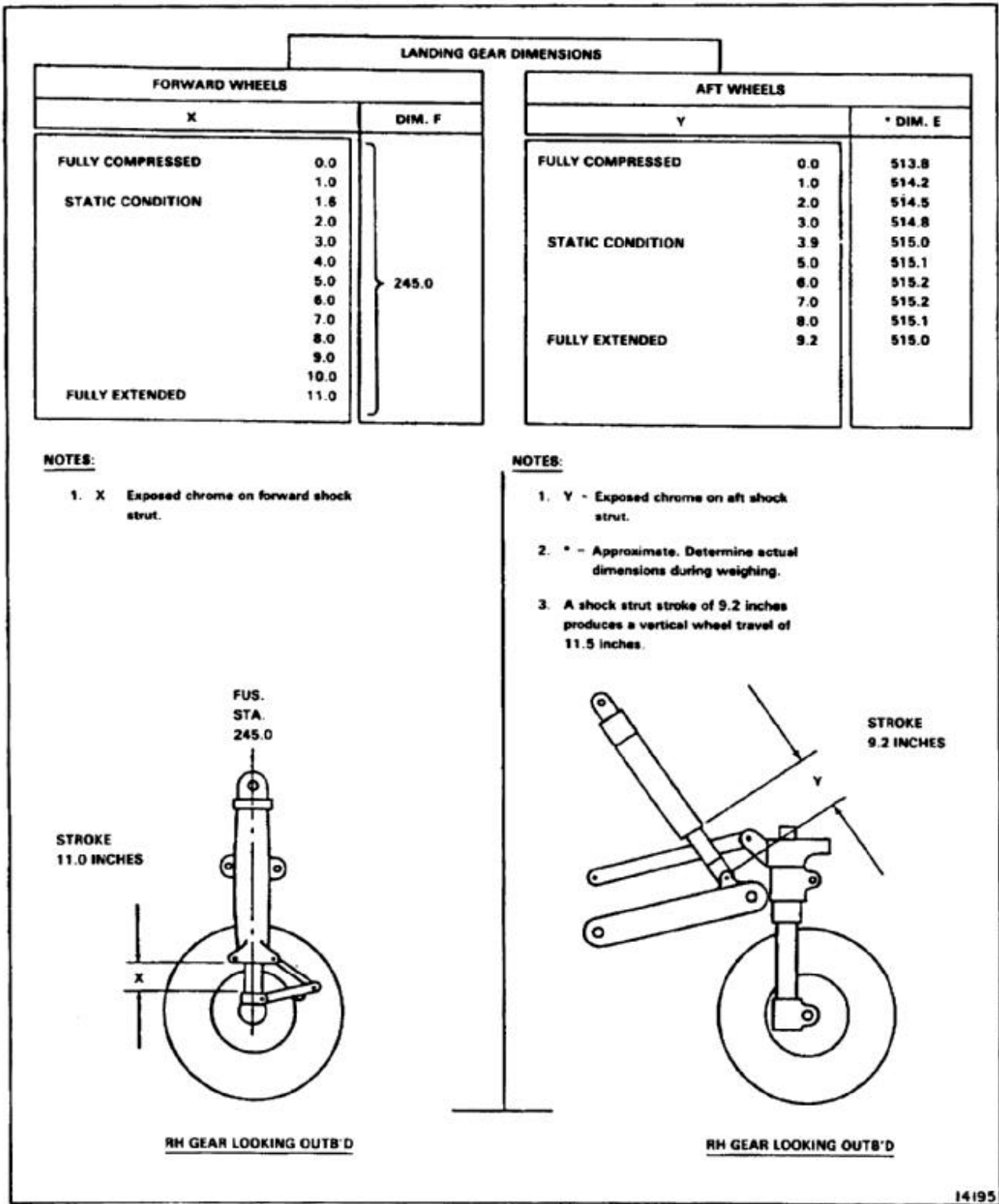

Figure G-5. Chart E (Sheet 1 of 23)



14195

Figure G-5. Chart E (Sheet 2 of 23)

FUEL LOADING CHART
MID TANKS

WEIGHT (LB)	ARM - 317.3 MOM/1000	WEIGHT (LB)	ARM - 317.3 MOM/1000	WEIGHT (LB)	ARM - 317.3 MOM/1000
50	15.9	1400	444.2	2750	872.6
100	31.7	1450	460.1	2800	888.4
150	47.6	1500	476.0	2850	904.3
200	63.5	1550	491.8	2900	920.2
250	79.3	1600	507.7	2950	936.0
300	95.2	1650	523.5	3000	951.9
350	111.1	1700	539.4	3050	967.8
400	126.9	1750	555.3	3100	983.6
450	142.8	1800	571.1	3150	999.5
500	158.7	1850	587.0	3200	1015.4
550	174.5	1900	602.9	3250	1031.2
600	190.4	1950	618.7	3300	1047.1
650	206.2	2000	634.6	3350	1063.0
700	222.1	2050	650.5	3400	1078.8
750	238.0	2100	666.3	3450	1094.7
800	253.8	2150	682.2	3500	1110.6
850	269.7	2200	698.1	3550	1126.4
900	285.6	2250	713.9	3600	1142.3
950	301.4	2300	729.8	*3627	1158.1
1000	317.3	2350	745.7	3650	1174.0
1050	333.2	2400	761.5	3700	1189.9
1100	349.0	2450	777.4	3750	1205.8
1150	364.9	2500	793.3	**3794	1221.6
1200	380.8	2550	809.1	3850	1237.5
1250	396.6	2600	825.0	3900	1253.3
1300	412.5	2650	840.8	3950	1269.2
1350	428.4	2700	856.7	4000	

NOTES:

1. Two Mid tanks. Fuel consumed simultaneously, 558 gallons, total.
2. Asterisk (*) indicates approximate weight and moment for full Mid tanks (100% self-sealing) based on JP-4 fuel (MIL-F-5624B) at 6.5 pounds per gallon.
3. Double asterisk (**) indicates approximate weight and moment for full Mid tanks (100% self-sealing) based on JP-5 fuel (MIL-F-5624B) at 6.8 pounds per gallon.
4. Total weight of fuel is dependent upon the specific gravity and temperature. Therefore, the notation "FULL" does not appear on the fuel quantity gages. Variation should be anticipated in gage readings when tanks are full.
5. See sheet 1 of 23 for tank arrangement.

14196

Figure G-5. Chart E (Sheet 3 of 23)

**FUEL LOADING CHART
FWD. & AFT TANKS**

NORMAL OPERATION		EMERGENCY OPERATION ONLY		
WEIGHT (LB)	COMMON ARM - 314.0 MOM/1000	WEIGHT (LB)	FORWARD ARM - 214.0 MOM/1000	AFT ARM - 414.0 MOM/1000
100	31.4	50	10.7	20.7
200	62.8	100	21.74	41.4
300	94.2	150	32.1	62.1
400	125.6	200	42.8	82.8
500	157.0	250	53.5	103.6
600	188.4	300	64.2	124.2
700	219.8	350	74.9	144.9
800	251.2	400	85.6	165.6
900	282.6	450	96.3	186.3
1000	314.0	500	107.0	207.0
1100	345.4	550	117.7	227.7
1200	376.8	600	128.4	248.4
1300	408.2	650	139.1	269.1
1400	439.6	700	149.8	289.8
1500	471.0	750	160.5	310.5
1600	502.4	800	171.2	331.2
1700	533.8	850	181.9	351.9
1800	565.2	900	192.6	372.6
1900	596.6	950	203.3	393.3
2000	628.0	1000	214.0	414.0
2100	659.4	1050	224.7	434.7
2200	690.8	1100	235.4	455.4
2300	722.2	1150	246.1	476.1
2400	753.6	1200	256.8	496.8
2500	785.0	1250	267.5	517.5
2600	816.4	1300	278.2	538.2
2700	847.8	1350	288.9	558.9
2800	879.2	1400	299.6	579.6
2900	910.6	1450	310.3	600.3
3000	942.0	1500	321.0	621.0
*3094	971.5	**1547	331.1	640.4
3200	1004.8	1600	342.4	662.4
**3236	1016.1	**1618	346.2	669.9
3300	1036.2	1650	353.1	683.1
3400	1067.6	1700	363.8	703.8
3500	1099	1750	374.5	724.5

Two fwd. and two aft tanks. Fuel consumed simultaneously, 476 gallons total.

Two fwd. and two aft tanks. Fuel consumed individually, 238 gallons fwd. and 238 gallons aft.

NOTES:

1. Asterisk (*) indicates approximate weight and moment for full fwd. and aft tanks (100% self-sealing) based on JP-4 fuel (MIL-F-5624B) at 6.5 pounds per gallon.
2. Double asterisk (**) indicates approximate weight and moment for full fwd. and aft tanks (100% self-sealing) based on JP-5 fuel (MIL-F-5624B) at 6.8 pounds per gallon.
3. Total weight of fuel is dependent upon the specific gravity and temperature. Therefore, the notation "FULL" does not appear on the fuel quantity gages. Variation should be anticipated in gage readings when tanks are full.
4. See sheet 1 of 23 for tank arrangement.

Figure G-5. Chart E (Sheet 4 of 23)

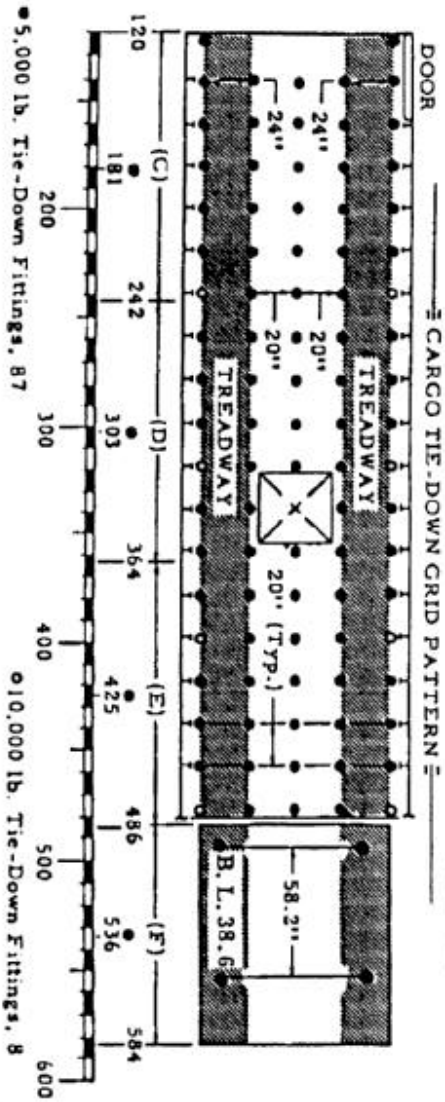

COMPARTMENT DATA							
COMPARTMENT DESIGNATION	PILOTS' (A)	EQUIP. (B)	CARGO			RAMP (F)	TAIL (G)
			(C)	(D)	(E)		
CENTROID Inches from Ref Datum	75	108	181	303	425	*536	607
FORWARD LIMIT Inches from Ref Datum	21.5	95	120	242	364	486	584
AFT LIMIT Inches from Ref Datum	95	120	242	364	486	584	630.5
MAXIMUM CAPACITY Pounds			** 22875	** 22875	** 22875	3000	
FLOOR AREA Square Feet			76.3	76.3	76.3	*61.8	
VOLUME Cubic Feet			491.3	491.3	491.3	*373.8	
MAXIMUM CAPACITY Pounds per Square Foot			300	300	300	300	
TREADWAY Max uniformly distributed load over limited area of 1 square foot or max load per wheel.			2500	2500	2500	2500	
CENTER SECTION Between treadway-max uniformly distributed load over limited area of 1 square foot or max load per wheel.			1000	1000	1000	1000	

NOTES: 1. RAMP (F) * based upon ramp open, level with floor plane.
 2. Centroids for Compartments C, D, E & F are based upon floor area.
 3. All volumes based upon projection of floor area to ceiling.
 4. **Do not exceed Gross Weight Limitations, see page 18 OF 23

Figure G-5. Chart E (Sheet 5 of 23)

14198

CARGO COMPARTMENT TABLE											
COMPARTMENT					COMPARTMENT						
C	D	E	F	C	D	E	F	C	F		
181	303	425	536	181	303	425	536	181	536		
WEIGHT (LB)		MOM/1000 for Arms Listed Above				WEIGHT (LB)		MOM/1000 for Arms Listed Above			
5	1	2	2	3	2400	434	727	1020	1286		
10	2	3	4	5	2600	471	788	1105	1394		
20	4	6	9	11	2800	507	848	1190	1501		
30	5	9	13	16	3000	543	909	1275	1608		
40	7	12	17	21	3500	634	1061	1488			
50	9	15	21	27	4000	724	1212	1700			
60	11	18	26	32	4500	815	1364	1913			
70	13	21	30	38	5000	905	1515	2125			
80	14	24	34	43	5500	996	1667	2338			
90	16	27	38	48	6000	1086	1818	2550			
100	18	30	43	54	6500	1177	1970	2763			
200	36	61	85	107	7000	1267	2121	2975			
300	54	91	128	161	7500	1358	2273	3188			
400	72	121	170	214	8000	1448	2424	3400			
500	91	152	213	268	8500	1539	2576	3613			
600	109	182	255	322	9000	1629	2727	3825			
700	127	212	298	375	9500	1720	2879	4038			
800	145	242	340	429	10000	1810	3030	4250			
900	163	273	383	482	11000	1991	3333	4675			
1000	181	303	425	536	12000	2172	3636	5100			
1100	199	333	468	590	13000	2353	3939	5525			
1200	217	364	510	643	14000	2534	4242	5950			
1300	235	394	553	697	15000	2715	4545	6375			
1400	253	424	595	750	16000	2896	4848	6800			
1500	272	455	638	804	17000	3077	5151	7225			
1600	290	485	680	858	18000	3258	5454	7650			
1700	308	515	723	911	19000	3439	5757	8075			
1800	326	545	765	965	20000	3620	6060	8500			
1900	344	576	808	1018	21000	3801	6363	8925			
2000	362	606	850	1072	22000	3982	6666	9350			
2200	398	667	935	1179	23000	4163	6969	9775			

Figure G-5. Chart E (Sheet 6 of 23)

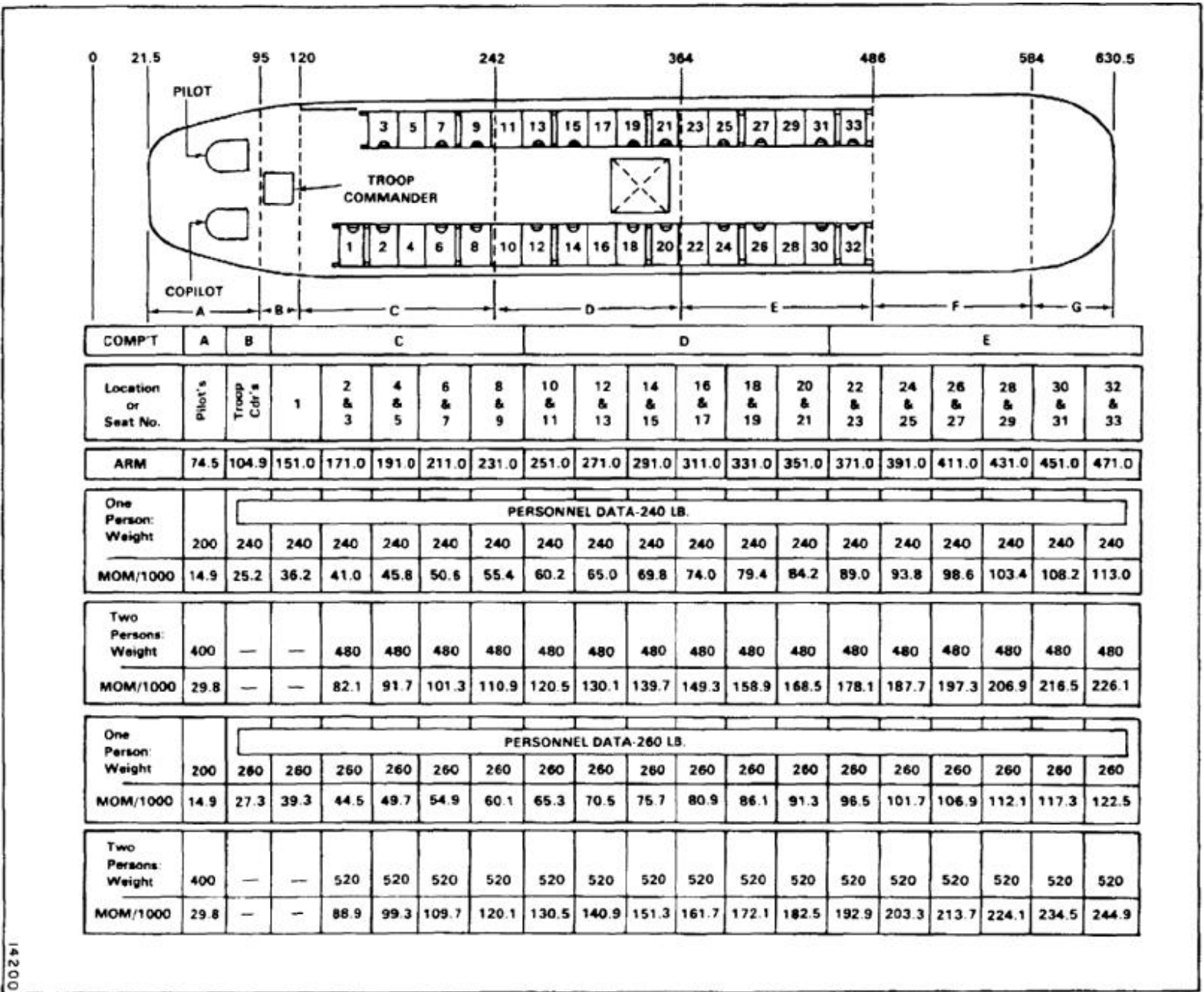

14200

Figure G-5. Chart E (Sheet 8 of 23)

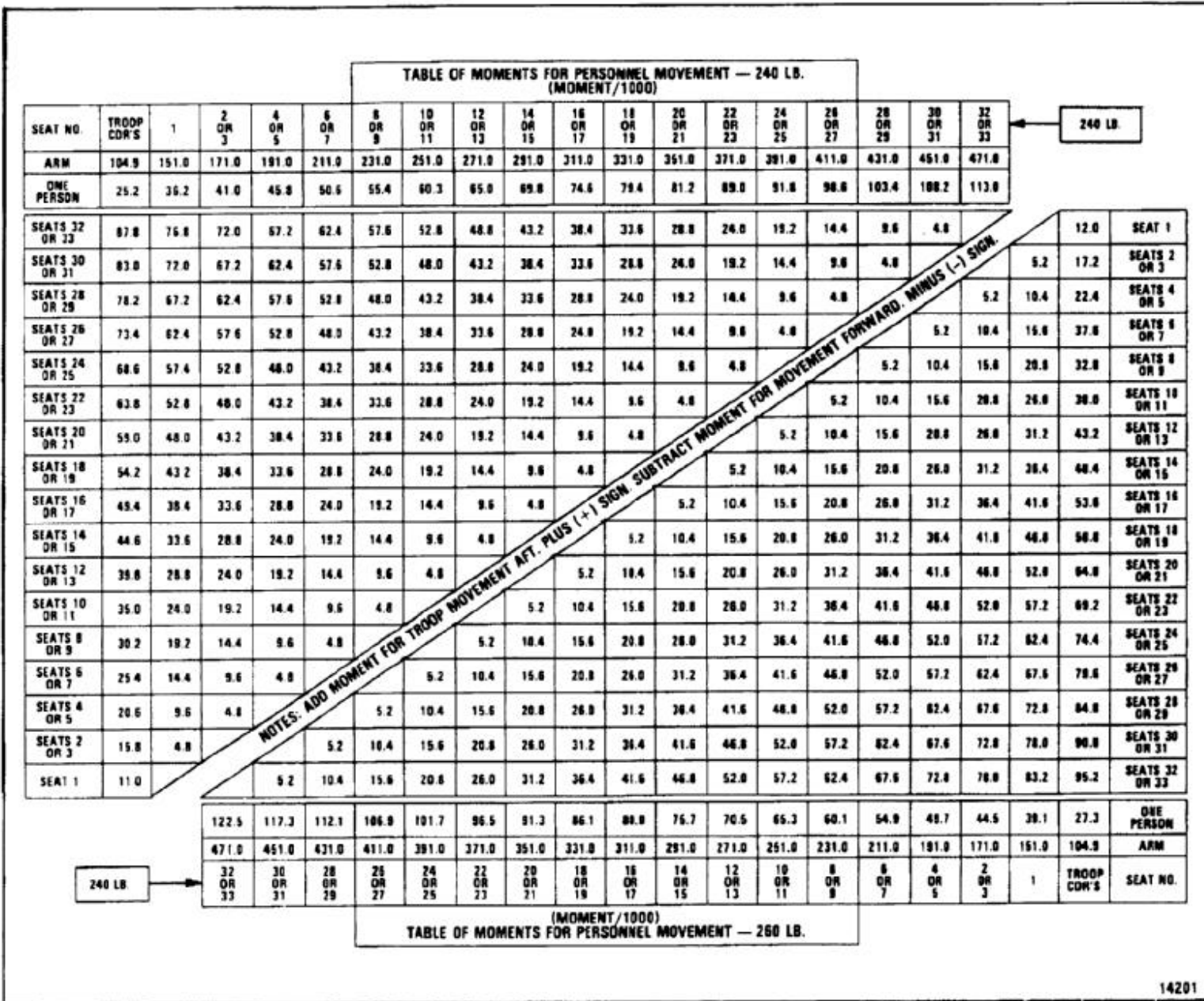

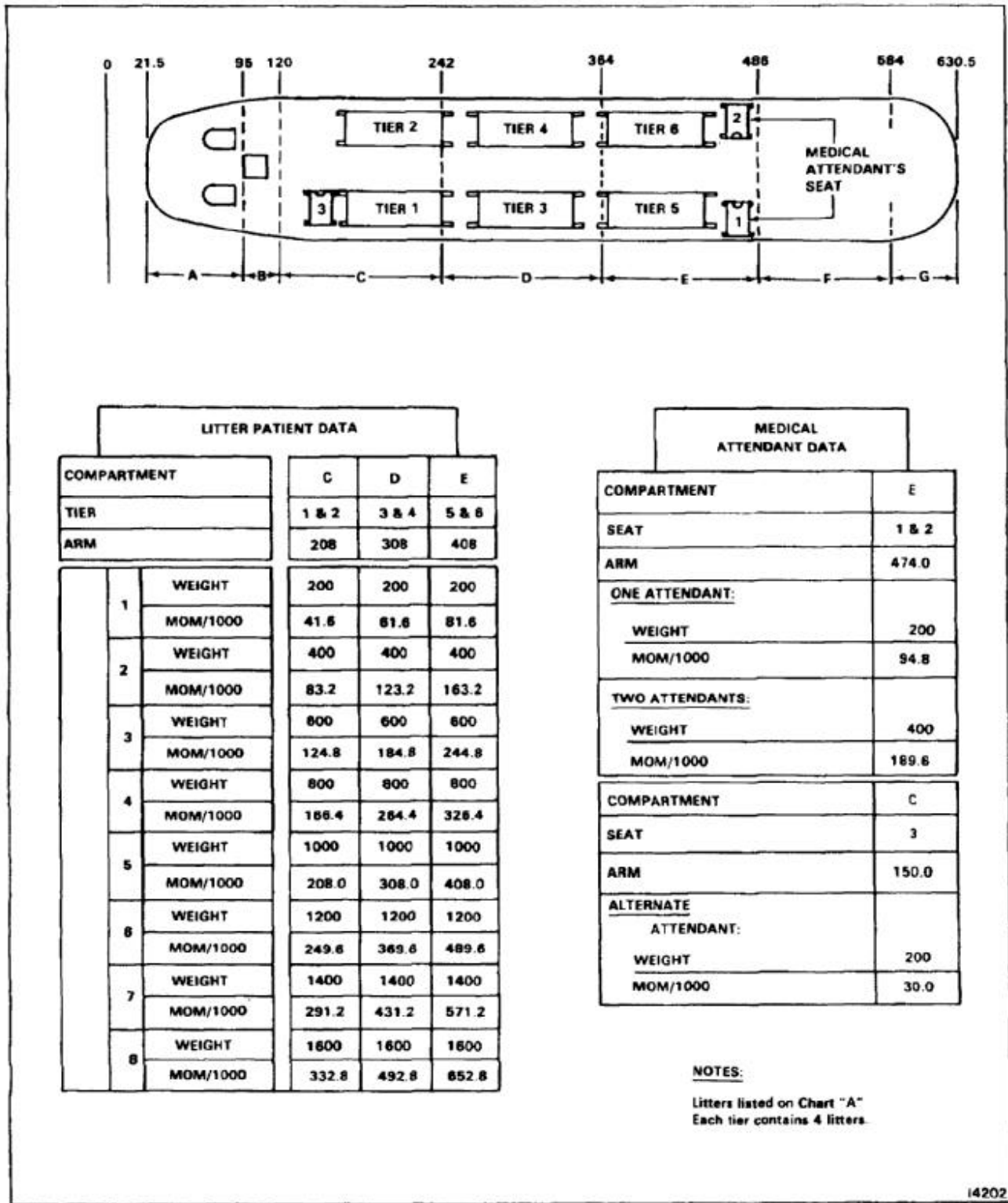

Figure G-5. Chart E (Sheet 9 of 23)

EXTERNAL CARGO HOOK LOADING CHART -CENTER			
ARM = 331.0		ARM = 331.0	
WEIGHT (LB)	MOM/1000	WEIGHT (LB)	MOM/1000
5	2	9000	2979
10	3	9500	3145
20	7	10000	3310
50	17	10500	3476
100	33	11000	3641
200	66	11500	3807
300	99	12000	3972
400	132	12500	4138
500	166	13000	4303
600	199	13500	4469
700	232	14000	4634
800	265	14500	4800
900	298	15000	4965
1000	331	15500	5131
1100	364	16000	5296
1200	397	16500	5462
1300	430	17000	5627
1400	463	17500	5793
1500	497	18000	5958
1600	530	18500	6124
1700	563	19000	6289
1800	596	19500	6455
1900	629	20000	6620
2000	662	20500	6786
2200	728	21000	6951
2400	794	21500	7117
2600	861	22000	7282
2800	927	22500	7443
3000	993	23000	7613
3500	1159	23500	7779
4000	1324	24000	7944
4500	1490	24500	8110
5000	1655	25000	8275
5500	1821	25500	8441
6000	1986	26000	8606
6500	2152	26500	8772
7000	2317	27000	8937
7500	2483	27500	9103
8000	2648	28000	9268
8500	2814		

14203

Figure G-5. Chart E (Sheet 10 of 23)

EXTERNAL - CARGO HOOK LOADING CHART - TANDEM			
COMMON ARM = 329.0		COMMON ARM = 329.0	
WEIGHT (LB)	MOM/1000	WEIGHT (LB)	MOM/1000
3	2	9000	2961
10	3	9500	3126
20	7	10000	3290
50	16	10500	3455
100	33	11000	3619
200	66	11500	3784
300	99	12000	3948
400	132	12500	4113
500	165	13000	4277
600	197	13500	4442
700	230	14000	4606
800	263	14500	4771
900	296	15000	4935
1000	329	15500	5100
1100	362	16000	5264
1200	395	16500	5429
1300	428	17000	5593
1400	461	17500	5758
1500	494	18000	5922
1600	526	18500	6087
1700	559	19000	6251
1800	592	19500	6416
1900	625	20000	6580
2000	658	20500	6745
2200	724	21000	6909
2400	790	21500	7074
2600	855	22000	7238
2800	921	22500	7403
3000	987	23000	7567
3500	1152	23500	7732
4000	1316	24000	7896
4500	1481	24500	8061
5000	1645	25000	8225
5500	1810		
6000	1974		
6500	2139		
7000	2303		
7500	2468		
8000	2632		
8500	2797		

14204

Figure G-5. Chart E (Sheet 11 of 23)

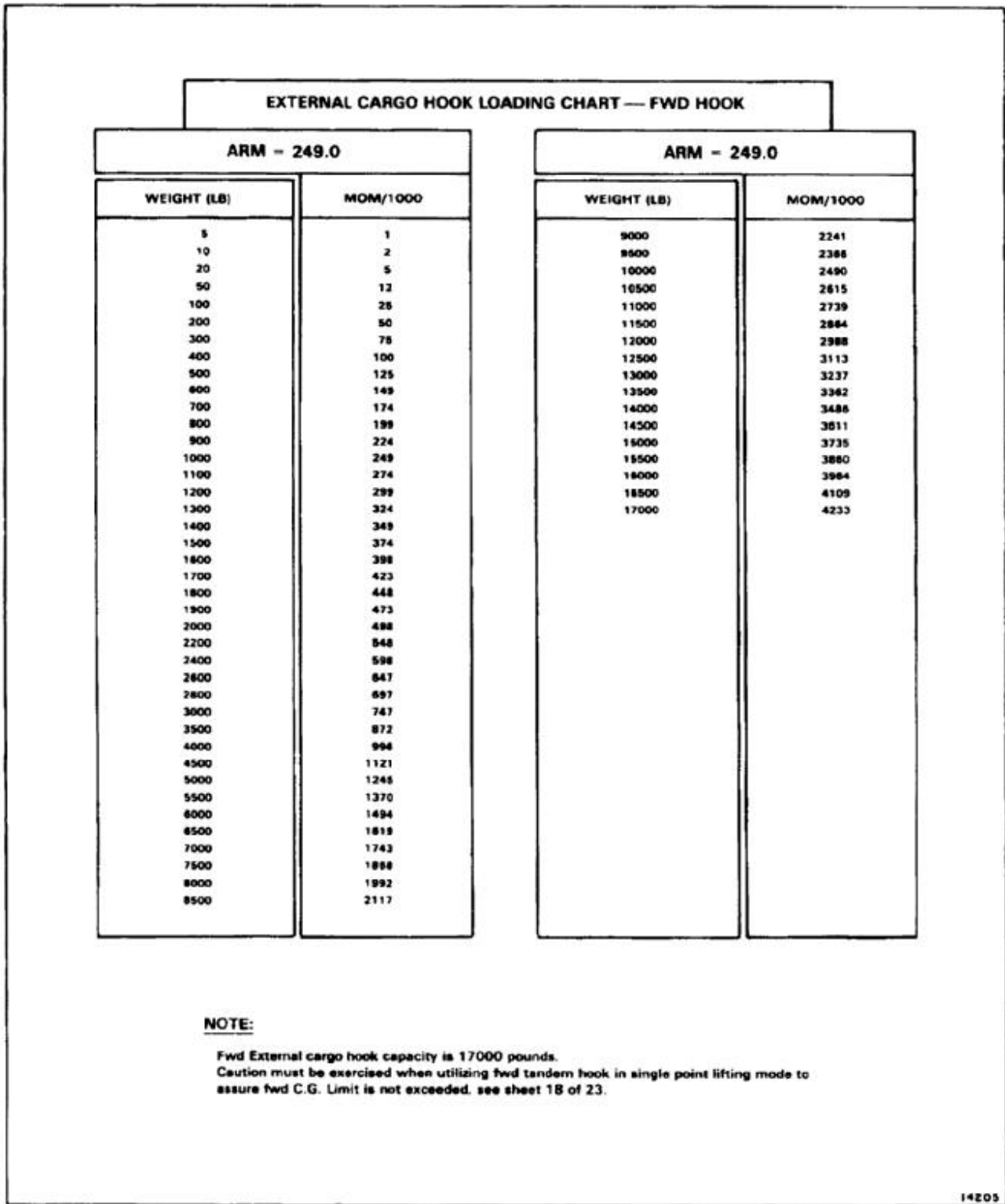

Figure G-5. Chart E (Sheet 12 of 23)

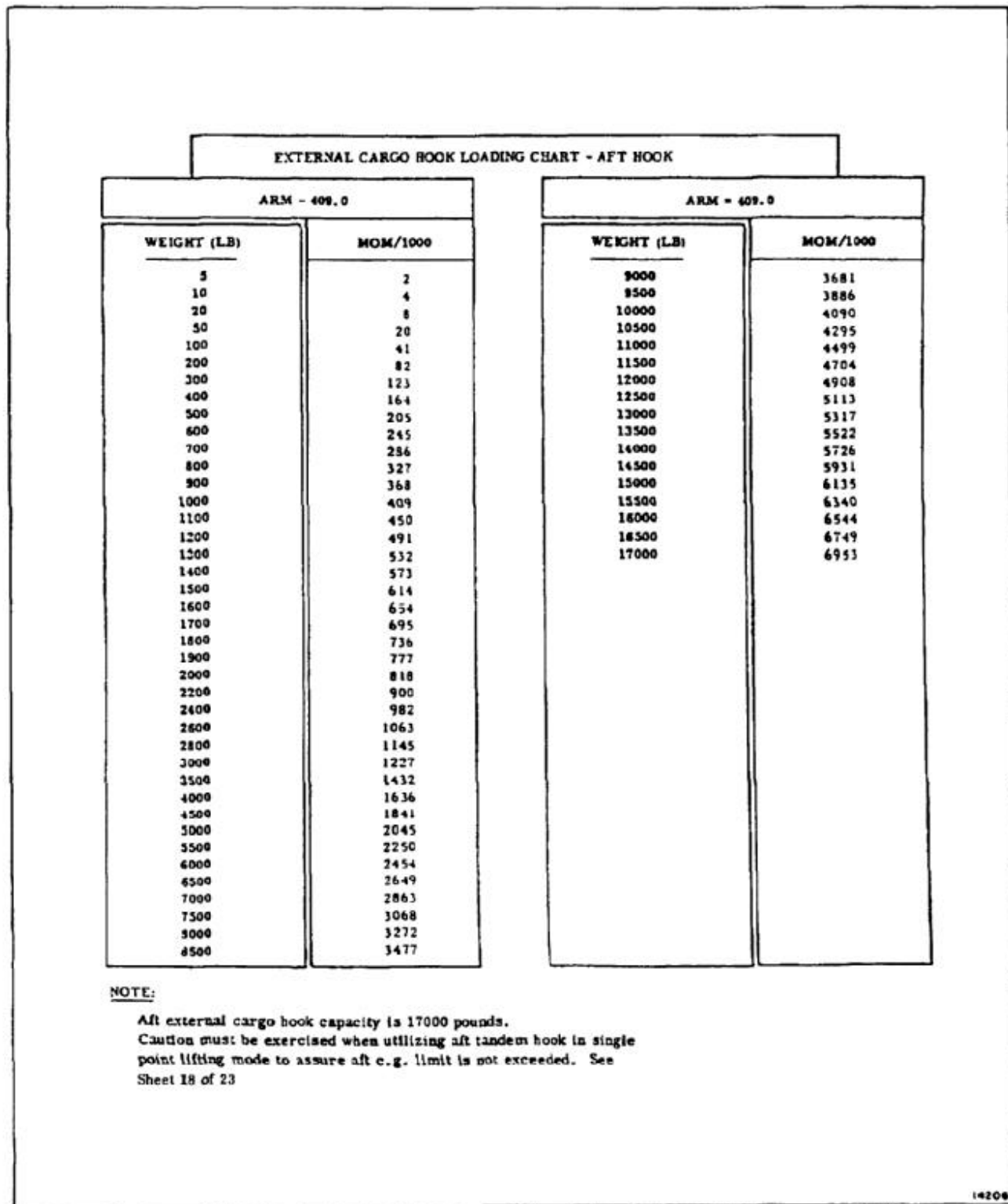

Figure G-5. Chart E (Sheet 13 of 23)

FERRY FUEL LOADING CHART				
WEIGHT (LB) (EACH TANK)	ARM - 194.5 MOM/1000	ARM - 253.5 MOM/1000	ARM - 312.5 MOM/1000	ARM - 371.5 MOM/1000
50	9.7	12.7	15.6	18.6
100	19.3	25.4	31.3	37.2
150	29.2	38.0	46.9	53.7
200	38.9	50.7	62.3	74.3
250	48.6	63.4	78.1	92.9
300	58.4	76.1	93.8	111.3
350	68.1	88.7	109.4	130.0
400	77.9	101.4	125.0	148.8
450	87.3	114.1	140.6	167.2
500	97.3	126.8	156.3	185.8
550	107.0	139.4	171.9	204.3
600	116.7	152.1	187.5	222.9
650	126.4	164.8	203.1	241.5
700	136.2	177.5	218.8	260.1
750	145.9	190.1	234.4	278.6
800	155.6	202.8	250.0	297.2
850	165.3	215.5	265.6	315.8
900	175.1	228.2	281.3	334.4
950	184.8	240.8	296.9	352.9
1000	194.5	253.5	312.5	371.5
1100	214.0	278.9	343.8	408.7
1200	233.4	304.2	375.0	446.8
1300	252.9	329.6	406.3	483.0
1400	272.3	354.9	437.5	520.1
1500	291.8	380.3	468.8	557.3
1600	311.2	405.6	500.0	594.4
1700	330.7	431.0	531.3	631.6
1800	350.1	456.3	562.5	668.7
1900	369.6	481.7	593.8	705.9
2000	389.0	507.0	625.0	743.0
2200	427.9	557.7	687.5	817.3
2400	466.8	608.4	750.0	891.6
2600	505.7	659.1	812.5	965.9
2800	544.6	709.8	875.0	1040.2
3000	583.5	760.5	937.5	1114.5
3200	622.4	811.2	1000.0	1188.8
3400	661.3	861.9	1062.5	1263.1
3600	700.2	912.6	1125.0	1337.4
3800	739.1	963.3	1187.5	1411.7
3900	758.6	988.7	1218.8	1448.9
4000	778.0	1014.0	1250.0	1486.0

NOTES

- Each moment column represents one ferry fuel tank (800 gallons each).
- Fuel can be consumed from any individual tank, any combination of tanks or simultaneously. The sequence can be alternated and is completely optional.
- Either one, two, three, or four tanks can be used.
- Asterisk (*) indicates approximate weight and moment for a full ferry fuel tank based on JP-4 fuel (MIL-E-5624B) at 6.5 pounds per gallon.

14207

Figure G-5. Chart E (Sheet 14 of 23)

FERRY OIL LOADING CHART		
4.20 GALLONS		ARM - 492.0
GALLONS	WEIGHT (LB.)	MOM/1000
1	8	3.9
2	15	7.4
3	23	11.3
4.2	32	15.7

14208

Figure G-5. Chart E (Sheet 15 of 23)

GROSS WT POUNDS	CENTER OF GRAVITY TABLE																	GROSS WT POUNDS			
	C G LIMITS																				
	← FWD C G LIMIT								→ AFT C G LIMIT												
	309 7	311	313	315	317	319	321	322	325	328	331	333	334	336	337	339	341	343	346	349	
	MOMENT / 1000																				
20000	06194	06220	06250	06300	06340	06380	06420	06440	06500	06560	06620	06680	06720	06740	06780	06820	06860	06920	06980	07000	20000
20400	06318	06344	06385	06426	06467	06508	06548	06569	06630	06691	06752	06793	06814	06854	06875	06916	06956	07058	07120	07120	20400
20800	06442	06469	06510	06552	06594	06635	06677	06698	06760	06822	06885	06926	06947	06988	07010	07051	07093	07134	07197	07259	20800
21200	06566	06593	06636	06678	06720	06763	06805	06826	06889	06954	07017	07060	07081	07123	07144	07187	07229	07272	07336	07399	21200
21600	06690	06718	06761	06804	06847	06890	06934	06955	07020	07085	07150	07193	07214	07258	07279	07322	07366	07409	07474	07538	21600
22000	06813	06842	06886	06930	06974	07018	07062	07084	07150	07216	07282	07326	07348	07392	07414	07458	07502	07546	07612	07678	22000
22400	06937	06966	07011	07055	07101	07146	07190	07213	07280	07347	07414	07459	07482	07526	07549	07594	07638	07683	07750	07818	22400
22800	07061	07091	07136	07182	07228	07273	07319	07342	07410	07478	07547	07592	07615	07661	07684	07729	07775	07820	07889	07957	22800
23200	07185	07215	07262	07308	07354	07401	07447	07470	07540	07610	07679	07725	07749	07795	07818	07865	07911	07958	08027	08097	23200
23600	07309	07340	07387	07434	07481	07528	07576	07599	07670	07741	07812	07859	07882	07930	07953	08000	08048	08095	08166	08236	23600
24000	07433	07464	07512	07560	07608	07656	07704	07728	07800	07872	07944	07992	08016	08064	08088	08136	08184	08232	08304	08376	24000
24400	07557	07588	07637	07686	07735	07784	07832	07857	07930	08003	08076	08125	08150	08198	08223	08272	08320	08369	08442	08516	24400
24800	07681	07713	07762	07812	07862	07911	07961	07986	08060	08134	08209	08258	08283	08333	08358	08407	08457	08506	08581	08655	24800
25200	07804	07837	07888	07938	07988	08039	08089	08114	08190	08266	08341	08392	08417	08467	08492	08543	08593	08644	08719	08795	25200
25600	07928	07962	08013	08064	08115	08166	08218	08243	08320	08397	08474	08525	08550	08602	08627	08678	08730	08781	08858	08934	25600
26000	08052	08086	08138	08190	08242	08294	08346	08372	08450	08528	08606	08658	08684	08736	08762	08814	08866	08918	08996	09074	26000
26400	08176	08210	08263	08316	08369	08422	08474	08501	08580	08659	08738	08791	08818	08870	08897	08950	09002	09055	09134	09214	26400
26800	08300	08335	08388	08442	08496	08549	08603	08630	08710	08790	08871	08924	08951	09005	09032	09085	09139	09192	09273	09353	26800
27200	08424	08459	08514	08568	08622	08677	08731	08758	08840	08922	09003	09058	09085	09139	09166	09221	09275	09330	09411	09493	27200
27600	08548	08584	08639	08694	08749	08804	08860	08887	08970	09053	09136	09191	09218	09274	09301	09356	09412	09467	09550	09632	27600
28000	08672	08708	08764	08820	08876	08932	08988	09016	09100	09184	09268	09324	09352	09408	09436	09492	09548	09604	09688	09772	28000
28500	08842	08879	08936	08993	09050	09107	09165	09193	09279	09364	09450	09507	09536	09593	09621	09678	09736	09793	09878	09964	28500
28800	08919	08957	09014	09072	09130	09187	09245	09274	09360	09446	09533	09590	09619	09677	09706	09763	09821	09878	09965	10051	28800
29200	09043	09081	09140	09198	09256	09315	09373	09402	09490	09578	09665	09724	09753	09811	09840	09898	09957	10016	10103	10189	29200
29600	09167	09206	09265	09324	09383	09442	09502	09531	09620	09709	09798	09857	09886	09946	09975	10034	10094	10153	10242	10329	29600
30000	09291	09330	09390	09450	09510	09570	09630	09660	09750	09840	09930	09990	10020	10080	10110	10170	10230	10290	10380	10468	30000
30400	09415	09454	09515	09576	09637	09698	09759	09789	09880	09971	10062	10123	10154	10214	10245	10306	10366	10427	10518	10607	30400
30800	09539	09579	09640	09702	09764	09825	09887	09918	10010	10102	10195	10256	10287	10349	10380	10441	10503	10564	10657	10745	30800
31200	09663	09703	09766	09828	09890	09953	10015	10046	10140	10234	10327	10390	10421	10483	10514	10577	10639	10702	10795	10883	31200
31600	09787	09828	09891	09954	10017	10080	10144	10175	10270	10365	10460	10523	10554	10618	10649	10712	10776	10839	10933	11021	31600
32000	09910	09952	10016	10080	10144	10208	10272	10304	10400	10496	10592	10656	10688	10752	10784	10848	10912	10976	11069	11157	32000
32400	10034	10076	10141	10206	10271	10336	10400	10433	10530	10627	10724	10789	10822	10886	10919	10984	11048	11113	11206	11294	32400
32800	10158	10201	10266	10332	10398	10463	10529	10562	10660	10758	10855	10920	10955	11021	11054	11119	11185	11250	11343	11431	32800
33000	10220	10263	10329	10395	10461	10527	10593	10626	10725	10824	10921	10986	11022	11088	11121	11187	11253	11319	11412	11500	33000
33500		10419	10486	10553	10620	10687	10754	10787	10888	10988	11089	11156	11189	11256	11290	11357	11424				33500
34000		10574	10642	10710	10778	10846	10914	10948	11050	11152	11254	11322	11356	11424	11458	11526	11594				34000
34400		10698	10767	10836	10905	10974	11042	11077	11180	11283	11386	11455	11490	11558	11593	11662	11730				34400
34800		10823	10892	10962	11032	11101	11171	11206	11310	11414	11519	11588	11623	11693	11728	11797	11867				34800
35200			11018	11088	11158	11229	11299	11334	11440	11546	11651	11722	11757	11827	11862	11933	12003				35200
35600			11143	11214	11285	11356	11428	11463	11570	11677	11784	11855	11890	11962	11997	12068	12140				35600
36000			11268	11340	11412	11484	11556	11592	11700	11808	11916	11988	12024	12096	12132	12204	12276				36000
36400			11393	11466	11539	11612	11684	11721	11830	11939	12048	12121	12158	12230	12267	12340	12412				36400
36800			11518	11592	11666	11739	11813	11850	11960	12070	12181	12254	12291	12365	12402	12475					36800
37200			11644	11718	11792	11867	11941	11978	12090	12202	12313	12388	12425	12499	12536	12611					37200
37600				11769	11844	11919	11994	12070	12182	12294	12406	12481	12518	12594	12631	12706					37600

Figure G-5. Chart E (Sheet 16 of 23)

SEE NOTES ON SHEET 18 OF 23

GROSS WT POUNDS		CENTER OF GRAVITY TABLE																GROSS WT POUNDS			
		← FWD C G LIMIT				C G LIMITS								AFT C G LIMIT →							
		309.7	311	313	315	317	319	321	322	325	328	331	333	334	336	337	339			341	343
MOMENT / 1000																					
38000		11970	12046	12122	12198	12236	12350	12464	12578	12654	12692	12768	12806	12882							38000
38400		12096	12173	12250	12326	12365	12480	12595	12710	12787	12826	12902	12941	13018							38400
38800		12222	12308	12377	12455	12494	12610	12726	12843	12920	12959	13037	13076	13153							38800
39200		12348	12426	12505	12583	12622	12740	12858	12975	13054	13093	13171	13210	13289							39200
39600		12474	12553	12632	12712	12751	12870	12989	13108	13187	13226	13306	13345	13424							39600
40000			12680	12760	12840	12890	13000	13120	13240	13320	13360	13440	13480								40000
40400			12807	12888	12968	13009	13130	13251	13372	13453	13494	13574	13615								40400
40800			12934	13015	13097	13138	13260	13382	13505	13586	13627	13708	13750								40800
41200			13060	13143	13225	13266	13390	13514	13637	13720	13761	13843	13884								41200
41600			13187	13270	13354	13395	13520	13645	13770	13853	13894	13978	14019								41600
42000			13314	13398	13482	13524	13650	13776	13902	13986	14028	14112	14154								42000
42400			13526	13610	13693	13736	13862	13987	14113	14197	14239	14324	14366								42400
42800			13653	13739	13822	13865	13991	14116	14242	14326	14368	14453	14495								42800
43200			13781	13867	13950	13993	14119	14244	14370	14454	14496	14581	14623								43200
43600			13908	13994	14077	14120	14246	14371	14497	14581	14623	14708	14750								43600
44000			14036	14122	14205	14248	14374	14499	14625	14709	14751	14836	14878								44000
44400			14164	14250	14333	14376	14502	14627	14753	14837	14879	14964	14996								44400
44800			14291	14377	14460	14503	14629	14754	14880	14964	14996	15081	15113								44800
45200				14509	14592	14635	14761	14886	14999	15083	15115	15200	15232								45200
45600				14638	14721	14764	14890	15015	15128	15212	15244	15329	15361								45600
46000				14766	14849	14892	15018	15143	15256	15340	15372	15457	15489								46000
46200				14894	14977	15020	15146	15271	15384	15468	15500	15585	15617								46200
46400				14894	14977	15020	15146	15271	15384	15468	15500	15585	15617								46400
46600				14959	15042	15085	15211	15336	15449	15533	15565	15650	15682								46600
46800				15023	15106	15149	15275	15400	15513	15597	15629	15714	15746								46800
47000				15087	15170	15213	15339	15464	15577	15661	15693	15778	15810								47000
47200				15151	15234	15277	15403	15528	15641	15725	15757	15842	15874								47200
47400				15215	15298	15341	15467	15592	15705	15789	15821	15906	15938								47400
47600				15280	15363	15406	15532	15657	15770	15854	15886	15971	16003								47600
47800				15344	15427	15470	15596	15721	15834	15918	15950	16035	16067								47800
48000				15408	15491	15534	15660	15785	15898	15982	16014	16100	16132								48000
48200				15528	15611	15654	15780	15905	16018	16102	16134	16220	16252								48200
48400				15585	15668	15711	15837	15962	16075	16159	16191	16276	16308								48400
48600				15643	15726	15769	15895	16020	16133	16217	16249	16334	16366								48600
48800				15714	15797	15840	15966	16091	16204	16288	16320	16405	16437								48800
49000					15778	15821	15947	16072	16185	16269	16301	16386	16418								49000
49200					15842	15885	16011	16136	16249	16333	16365	16450	16482								49200
49400					15907	15950	16076	16201	16314	16398	16430	16515	16547								49400
49600					15971	16014	16140	16265	16378	16462	16494	16579	16611								49600
49800					16036	16079	16205	16330	16443	16527	16559	16644	16676								49800
50000					16100	16143	16269	16394	16507	16591	16623	16708	16740								50000

SEE NOTES ON SHEET 18 OF 25



Figure G-5. Chart E (Sheet 17 of 23)

NOTES FOR CENTER OF GRAVITY TABLE

1. Explanation of center of gravity limits:

Fwd - The forward CG limit is 21.3 inches forward of the datum line between rotors, up to the gross weight of 33000 pounds. This limit varies in a linear manner from 21.3 inches forward at the gross weight of 33000 pounds to 12 inches forward of the datum line between rotors, at the gross weight of 44800 pounds and to 9.0 inches forward of the datum line between rotors, at the gross weight of 50000 pounds. (See illustration below.)

Aft - The aft CG limit is 18 inches aft of the datum line between rotors, up to the gross weight of 28550 pounds. This limit varies in a linear manner from 18 inches aft at the gross weight of 28550 pounds to 12 inches aft of the datum line between rotors, at the gross weight of 33000 pounds and to 5 inches aft of the datum line between rotors, at the gross weight of 44800 pounds and to 0.0 inches (datum line between rotors) at the gross weight of 50000 pounds. (See illustration below.)

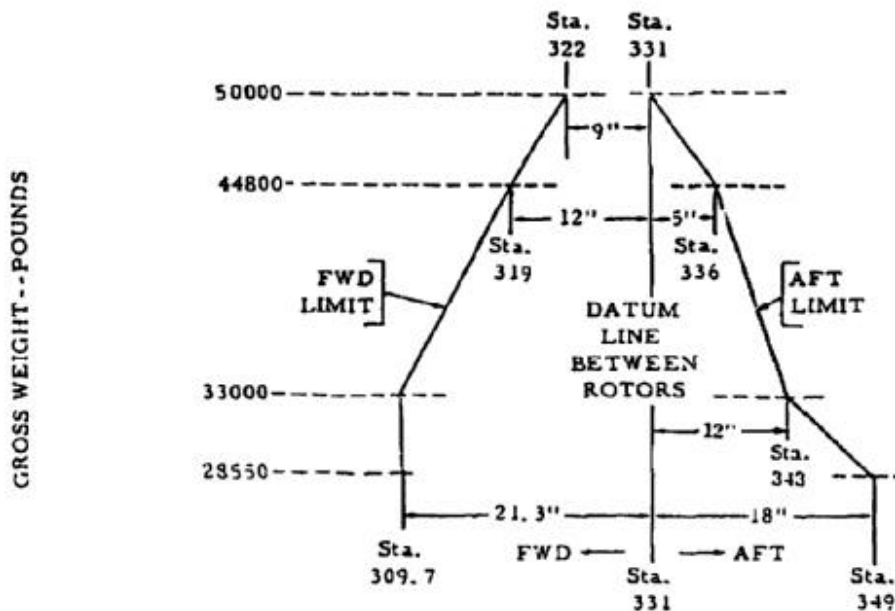

2. Gross weight limitations:

Takeoff _____ Pounds*
 Landing _____ Pounds*

*NOTE: Service activities shall insert, or substitute, current figures from latest applicable technical manual covering operating restrictions.

14211

Figure G-5. Chart E (Sheet 18 of 23)

**MAXIMUM PACKAGE SIZE TABLE
FORWARD DOOR--RIGHT SIDE**

WIDTH (Inches)	HEIGHT--INCHES									
	53 & Under	54	55	56	57	58	59	60	61	62
	MAXIMUM LENGTH--INCHES									
12	249	246	242	238	234	223	170	170	170	165
13	233	230	227	224	221	211	162	162	162	157
14	217	215	213	210	208	199	154	154	154	150
15	205	204	203	199	197	187	147	147	147	144
16	195	194	193	189	187	176	141	141	141	138
17	186	185	183	180	178	166	136	136	136	133
18	177	176	174	172	170	157	131	131	131	128
19	169	168	166	164	162	149	126	126	126	124
20	161	160	159	157	155	142	122	122	122	120
21	155	154	153	151	148	135	118	118	118	116
22	149	148	147	145	141	129	114	114	114	112
23	143	143	142	140	135	124	111	111	111	109
24	138	138	137	135	129	119	108	108	108	106
25	133	133	132	130	124	114	105	105	105	103
26	128	128	127	125	119	110	103	103	103	101
27	125	124	123	121	115	106	101	101	101	99

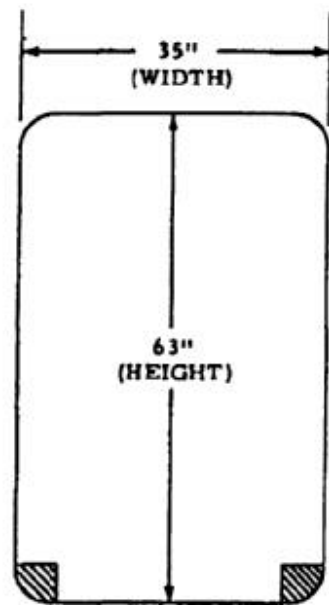

NOTE:
Shaded part shows approximate area obstructed due to door opening linkage.

Figure G-5. Chart E (Sheet 19 of 23)

14212

MAXIMUM PACKAGE SIZE TABLE RAMP DOOR																
WIDTH (INCHES)	HEIGHT - INCHES															
	62 & Under	63	64	65	66	67	68	69	70	71	72	73	74	75	76	77
	MAXIMUM LENGTH-- INCHES															
62 & Under	362	362	362	362	362	362	362	362	330	282	230	180	135	100	67	30
63	362	362	362	362	362	362	362	362	328	280	228	178	133	98	66	
64	362	362	362	362	362	362	362	362	326	278	226	176	130	96	64	
65	362	362	362	362	362	362	362	362	322	274	222	173	127	93		
66	362	362	362	362	362	362	362	362	318	270	218	169	123	90		
67	362	362	362	362	362	362	362	362	313	266	214	165	119	86		
68	362	362	362	362	362	362	362	357	307	260	208	160	114	81		
69	362	362	362	362	362	362	362	348	299	252	201	154	107	75		
70	362	362	362	362	362	362	362	339	290	243	193	146	99			
71	362	362	362	362	362	362	362	330	281	234	185	139	91			
72	362	362	362	362	362	362	362	321	272	226	177	131	83			
73	362	362	362	362	362	362	352	312	263	216	167	122	75			
74	362	362	362	362	362	362	339	298	250	203	156	112				
75	362	362	362	362	362	362	325	284	237	190	144	101				
76	362	362	362	362	362	348	311	270	223	177	132	90				
77	362	362	362	362	362	334	297	256	209	164	119					
78	362	362	362	362	346	316	278	237	191	147	104					
79	362	362	362	362	329	298	258	218	173	129	85					
80	362	362	362	362	310	276	236	195	151	108						
81	362	362	362	362	289	253	213	172	128	85						
82	362	362	362	362	267	230	188	148	105							
83	362	362	362	362	241	202	161	121								
84	362	362	362	362	213	174	133	93								
85	362	362	362	362	182	142	100									
86	362	362	362	362	146	105										
87	362	362	362	362	105											
88	362	362	362	362												
89	362	362	362	362												
90	362															

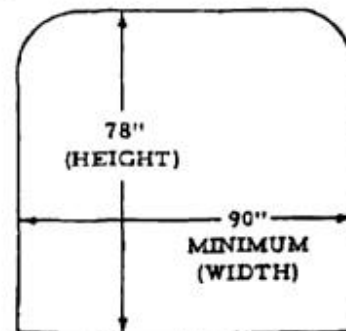

14214

Figure G-5. Chart E (Sheet 21 of 23)

MISCELLANEOUS DATA

<u>GENERAL HELICOPTER DIMENSIONS</u>	(Inches)
ROTOR BLADE DIAMETER	720.0
DISTANCE BETWEEN CENTER LINE OF ROTORS.....	470.0
SPAN--MINIMUM; BLADES UNFOLDED, STATIC, DEPHASED	540.0
(One Blade Each Rotor, At Right Angles to Center Line of Aircraft, Both Rotors Same Attitude)	
SPAN--MINIMUM; BLADES UNFOLDED, STATIC, IN PHASE	624.0
(One Blade, Either Rotor on \bar{C}_L Aircraft)	
SPAN--BLADES FOLDED	149.0
LENGTH--MINIMUM; BLADES UNFOLDED, STATIC, DEPHASED.....	827.0
(One Blade of Forward Rotor on \bar{C}_L Aft, One Blade of Aft Rotor on \bar{C}_L Forward)	
LENGTH--MINIMUM; BLADES UNFOLDED, STATIC, IN PHASE	1007.0
(One Blade, Either Rotor, On Center Line of Aircraft and In Forward Position)	
LENGTH--BLADES FOLDED--FUSELAGE	609.0
HEIGHT--FORWARD AND AFT LANDING GEAR STRUTS FULLY COMPRESSED ...	221.0
HEIGHT--STATIC	225.0
HEIGHT--FORWARD AND AFT LANDING GEAR STRUTS FULLY EXTENDED.....	232.0
WHEEL BASE	270.0
TREAD--FORWARD.....	126.0
TREAD--AFT.....	134.0

14215

Figure G-5. Chart E (Sheet 22 of 23)

TYPICAL SERVICE LOAD EXAMPLES

The basic weights and moments/1000 are normally obtained from Chart C, where they are the last figures shown in the weight and moment columns. For the purpose of these examples, it is assumed that the basic weights and moments are as shown. The following calculations are normally accomplished by utilizing weight and balance clearance Form F.

ITEM	ARM	CARGO		TROOP		LITTER		FERRY	
		WT	MOM 1000	WT	MOM 1000	WT	MOM 1000	WT	MOM 1000
BASIC WEIGHT		23363	7908.8	23472	7957.9	23863	8089.7	28253	8818.7
Cargo									
Internal-Compt C	181.0	4775	865.0						
Internal-Compt D	303.0	4774	1447.2						
Internal-Compt E	425.0	4775	2030.0						
External-Fwd Hook	249.0	1000	249.0						
External-Ctr Hook	331.0	2000	882.0						
External-Aft Hook	408.0	2000	818.0						
Pilot & Copilot	74.5	400	29.3	400	29.8	400	29.8	400	29.8
Flight Engineer (At Troop Cdr Loc)	104.9	200	21.0					200	21.0
Troop Commander	104.9			240	25.2				
Troops									
Compt C Seat 1 thru 9	195.4			2180	422.2				
Compt D Seat 10 thru 21	301.0			2880	867.0				
Compt E Seat 22 thru 33	421.0			2880	1212.7				
Litter Patients									
Tier 1 & 2 (8)	208.0					1600	332.8		
Tier 3 & 4 (7)	308.0					1400	431.2		
Tier 5 & 6 (6)	408.0					1200	489.6		
Medical Attendant (2)	471.0					400	189.4		
MINIMUM LANDING GROSS WEIGHT & MOMENT		43277	14030.8	32032	10514.8	28865	9541.5	28853	8867.5

The total weight and moment, as located on the center of gravity limit table, fall within the recommended CG limits. Therefore, the loading is satisfactory for landing.

LANDING WEIGHT & MOMENT		43277	14030.8	32032	10514.8	28865	9541.5	28853	8867.5
Fuel-Mid Tanks	317.3	3662	1162.0	3662	1162.0	3662	1162.0	3662	1162.0
Fuel-Fwd & Aft Tanks	314.0	1811	505.9			3103	974.3	3103	974.3
Fuel-Ferry	312.5							18350	5117.8
Oil-Ferry	492.0							32	15.7
TAKEOFF WEIGHT & MOMENT		48550	15698.7	35694	11676.8	35630	11677.3	50000	16137.1

The total weight and moment, as located on the center of gravity limit table, fall within the recommended CG limits. Therefore, the loading is satisfactory for takeoff.

Figure G-5. Chart E (Sheet 23 of 23)

SECTION III

G-12. Aircraft Weighings.

- Aircraft must be weighed.
- Periodically as required by pertinent directives. (Refer to AR 95-16.)
 - When major modifications or repairs are made.
 - When the pilot reports unsatisfactory flight characteristics (nose or tail heaviness).
 - When the basic weight data is suspected to be in error. The basic weight and CG location obtained from a weighing can be only as accurate as the scale equipment employed. Scales must be calibrated as required by existing directives.

G-13. Preliminary weighing instructions.

- Preliminary weighing instructions are as follows:
- Assemble necessary equipment, including scales, hoisting equipment, jacks, cribbing, leveling bars, level, measuring tape, plumb bob, and string.
 - Remove dirt, grease, moisture, etc., from aircraft.
 - Drain fuel from all tanks, using tank drains, with aircraft in its normal attitude on ground. If impracticable to drain due to fire hazard or local regulations, fill to capacity. Since weight of fuel varies with temperature, determine actual weight per gallon by use of a hydrometer. Multiply by gallons capacity, obtained from loading data sheets, for total fuel weight. Never weigh with partially filled tanks.



If the helicopter is to be weighed with full fuel tanks, the helicopter must be weighed using the 4 point method.

- Fill oil tanks to operating capacity.
- Fill hydraulic systems and reservoirs to normal levels.
- Inflate or deflate main landing gear oleo struts to normal extension or to anticipated desired height. It may be helpful for leveling and in jacking to lash a rope around the torque arm of the forward landing gear and apply the aft shock strut static lock so that the strut will not extend when the aircraft is lifted.
- Conduct an inventory of fixed operating equipment actually installed in aircraft. This shall be accomplished on the Basic Weight Check List, DD Form 365-1.

NOTE

A basic weight without the equivalent inventory is of no value to the activity receiving the aircraft.

- Release brakes before aircraft is placed on scales to reduce possibility of side loads and thrusts on scales which may give erroneous weighing results.
- Jacking the aircraft shall be accomplished in accordance with requirements of Chapter 1 of the -23 maintenance manual. Refer to Figure G-6 for location of jack pads and weight restrictions.

NOTE

The aircraft must be weighed in a closed hangar.

G-14. Weighing equipment. Weighing aircraft with accurately calibrated scales is the only sure method of obtaining an accurate basic weight and CG location. Reference is made to TM 55-1500-342-23 for use of the electronic weighing kit. Additional instruction for aircraft weighing that is not contained in TM 55-1500-342-23 for the individual aircraft shall be covered in this section.

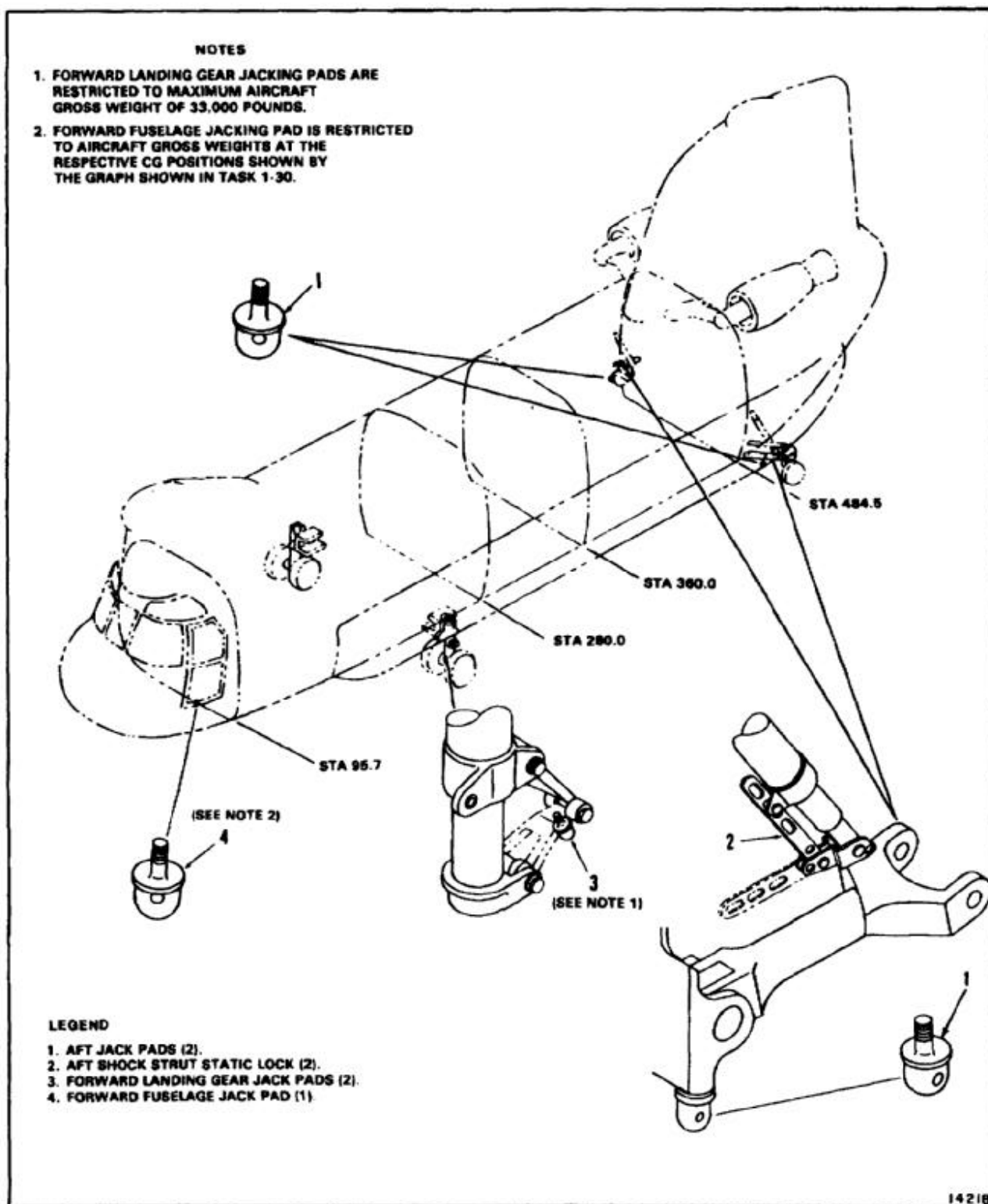

Figure G-7. Jack Pad Locations

APPENDIX H STORAGE OF AIRCRAFT

(See Chapter 1, Section IX)

APPENDIX J TORQUE LIMITS

(See Chapter 1, Task 1-13)

APPENDIX K MARKING INFORMATION

(See Chapter 2, Section VI)

GLOSSARY

Section I ABBREVIATIONS

TERM	DEFINITION
ac	alternating current
acft	aircraft
actr	actuator
adf	automatic direction finder
AFCS	automatic flight control system
agb	accessory gearbox
agl	above ground level
AIMS	Altitude Information Monitoring System
al	aluminum
ALE	automatic link establishment
alct	aft longitudinal cyclic trim
altm	altimeter
ang	angle
ANVIS	aviation night vision imaging system
appx	appendix
approx	approximately
APU	auxiliary power unit
assy	assembly
attn	attention
aux	auxiliary
bat	battery
bc	bolt circle
bite	built-in test equipment
bk	brake
bkr	breaker
bl	butt line
brkr	breaker
bst	boost
btry	battery
byp	bypass
C	Celsius (C)
cap	capacity
cb	circuit breaker
cbore	counterbore
cc	cubic centimeter
CCDA	cockpit control driver actuator
ccu	converter control unit
ccw	counterclockwise
CDTS	Countermeasure Dispenser Test Set
CF, BR	monobromotrifluoromethane
cg	center of gravity
CGI	Cruise Guide Indicator
ch	chapter
ckpt	cockpit
ckt	circuit
cmds	countermeasures dispenser system
cmps	compass
co	cutout

TERM

DEFINITION

CO ₂	carbon dioxide
col.....	column
condition.....	condition
cont.....	control
conv.....	converter
cpit.....	copilot
cpo.....	complete provisions only
cps.....	cycles per second
cpt.....	cockpit position transducer
cres.....	corrosion resistant steel
crks.....	crash resistant fuel system
csk.....	countersink
ctr.....	center
cw.....	clockwise
dash.....	differential airspeed hold actuator
dc.....	direct current
DCDU.....	digital control display unit
dcp.....	differential collective pitch
DE.....	dial empty
dec.....	decrease
deg.....	degree
det.....	detector
dia.....	diameter
dim.....	dimension
disc.....	disconnect
distr.....	distribution
dmwr.....	depot maintenance work requirement
dn.....	down
du.....	display unit
dwg.....	drawing
dx.....	direct exchange
ea.....	each
egt.....	exhaust gas temperature
emer.....	emergency
emf.....	electromotive force
eng.....	engine
equrv.....	equivalent
ESU.....	electronic sequencing unit
ext.....	external
ext.....	extinguisher
F.....	Fahrenheit
FAT.....	free air temperature
fed.....	federal
fig.....	figure
flt.....	flight
flct.....	foward longitudinal cyclic trim
fod.....	foreign object damage
ftlb.....	foot pound
FSN.....	federal stock number
fwd.....	forward
gal.....	gallon
gen.....	generator

TERM	DEFINITION
gpm.....	gallons per minute
gnd.....	ground
gse.....	ground support equipment
hex.....	hexagon
hf.....	high frequency
Hg.....	mercury
HIT.....	Health Indicator Test
HUD.....	head up display
hydr.....	hydraulic
Hz.....	Hertz (cyclespersecond)
ias.....	indicated air speed
id.....	inside diameter
iff.....	identification friend or foe
ign.....	ignition
ILCA.....	integrated lower control actuator
imp.....	imperial (measurement)
in.....	inch
in. lb.....	inch-pound
incr.....	incremental
ind.....	indicator
inst.....	instrument
instpn.....	instrument panel
instr.....	instrument
JMR.....	jammer
kn.....	knot
knts.....	knots
kva.....	kilovolt-ampere
l.....	left
lb.....	pound
lbft.....	poundfoot
lb in.....	pound-inch
LCT.....	longitudinal cyclic trim
le.....	leading edge
lf.....	low frequency
lg.....	length
lh.....	lefthand
long.....	longitudinal
los.....	line of sight
lt.....	sight
LVDT.....	linear variable differential transducer
mac.....	maintenance allocation chart
mag.....	magnetic
manf.....	manifold
max.....	maximum
mdf.....	mission data file
mfg.....	manufacturing
mil.....	military
min.....	minimum
misc.....	miscellaneous
mot.....	motor
mph.....	miles per hour
mpi.....	magnetic particle inspection

TERM

DEFINITION

MWO	Modification Work Order
MWS	missile warning system
na	not applicable
nac	nacelle
neg	negative
NC	normally closed
NO	normally open
No	number
norm	normal
N1	gas producer (speed)
N2	power turbine (speed)
NR	Rotor Speed (in rpm)
nrp	normal rated power
od	outside diameter
ofp	operational flight program
ohco	over haul change order
oper	operating
ou	optical unit
ovhd	overhead
P ₃	compress discharge pressure
para	paragraph
pf	picofarad
ph	phase
phr	pounds per hour
ph	pilot
PMG	permanent magnetic generator
pmp	pump
pms	Preventive Maintenance Services
pot	panel
P/O	part of
pos	positive
posn	position
press	pressure
pn	primary
prim	primary
PRG or PROG	program
psas	pitch stability augmentation system
pscu	power supply calibration unit
pst	pounds per square inch
psta	pounds per square inch absolute
psid	pounds per square inch differential
psig	pounds per square inch gauge
pt	point
PTIT	power turbine inlet temperature
pwr	power
pws	proximity warning system
qt	quart
qty	quantity
r	right
rad	radius
rcco	reverse current cutout
recp	receptacle
rect	rectifier

TERM	DEFINITION
ref	reference
reg	regulator
rel	release
rev cur	reverse current
rh	right hand
rhr	roughness height rating
rise	release
rly	relay
rmi	radio magnetic indicator
rms	root mean square
rmte	remote
rpm	revolutions per minute
rpstl	repair parts and special tools list
RWR	radar warning receiver
seem	standard cubic centimeters per minute
scfm	standard cubic feet per minute
sdc	signal data converter
scr	silicon controlled rectifier
set	second
set	secondary
sect	second
seq	sequence
sh	sheet
shp	shaft horsepower
sie	standard inspection equipment
sig	signal
sol	solenoid
spec	specification
sply	supply
STA	station
std	standard
strg	steering
subq	subsequent
SW	switch
sync	synchronizing
sys	system
tach	tachometer
tas	true airspeed
tbo	time between overhaul
tc	thermocouple
te	trailing edge
teat	turbine engine analysis check
temp	temperature
thd	thread
tir	total indicator reading
trq	torque
typ	typical
uhf	ultra high frequency
umlv	universal memory loader verifier
unk	unknown

TERM	DEFINITION
US	United States
util	utility
uuf	micromicrofarad
u/w	used with
v	volt
va	volt-ampere
vat	volts alternating current
var	volt-ampere reactive
vdc	volts direct current
vgl	vertical gyro indicator
vhf	very high frequency
vl	varies with load
vne	velocity never exceed
vs	versus
wl	waterline
wshld	windshield
wt	weight
xmitr	transmitter
xmsn	transmission
3 pdt	triple pole double throw

Section II DEFINITION OF UNUSUAL TERMS

TERM	DEFINITION
aerodynamic	Pertaining to motion of air acting on aircraft.
anodizing	Treatment of exterior aluminum alloy parts to prevent corrosion.
ballastd	Added weight to gain stability.
bowing	Curving or gradual change from original line or plane. Usually caused by lateral force or heat.
brinelling	Circular indentations on surface of bearing races. Usually caused by shock loading of balls or rollers.
burnishing	Smoothing minor damage using a hand tool.
burr	Rough edge or sharp protrusion on edge or surface.
chafing	Damage caused by two parts rubbing together.
chamfer	Beveled edge.
chromidize	Treatment for aluminum alloys to receive organic finish.
coaling	Raised frame around door.
delamination	Separation of material layers.
excluder	Screen that will prevent passage of particles larger than allowable size.
extruded	Formed by forcing through a shaped hole in a die.
ferrules	Metal band or socket.
frayed	Worn into shreds by rubbing action.
fusion	Joining together of two materials. Usually caused by heat, friction, or electrical current.
galling	Fretting or wearing away by friction.
gouged	Scooping out of material.
graduate	Mark with measurements.
impregnated	Saturated or soaked.
inclinometer	A device used to measure the angle from the horizontal.
insulate	Restrict passage of heat or sound.
integral	Formed as a unit with another part.
lee side	Downwind side.
limited measures	Measures used only if preferred equipment or materials are not available.
manometer	An instrument for measuring pressure.
nicked	A sharp surface indentation. Parent material is displaced, seldom separated.
oilcanning	Skin that springs back when pressed in like an oil can.
pawl	A pivoted lever that allows another part to move only in one direction.
pitting	Small irregular shaped cavities, usually caused by corrosion, chipping, or heavy electrical discharge.
radius	Distance from center to edge of circle. Half the diameter.
scored	Deep scratch or scratches. Material is removed.
scratched	Light, narrow, shallow, mark or marks on surface. Material is displaced, not removed.
sheet	A broad, thin surface of material.
spalling	Rough area resulting from progressive chipping away of material.
tacky	Sticky to the touch.
transverse	In a side-to-side direction

INDEX

ALPHABETICAL INDEX

	Task	Page
A		
Absorber, Dynamic, Cockpit		
Install	2-146	2-492
Remove	2-145	2-489
Absorber, Dynamic, Nose		
Install	2-143	2-481
Remove	2-139	2-472
Absorber, Dynamic, Test Box		
Install	2-148	2-498
Remove	2-147	2-497
Absorber Adapter, Dynamic		
Installation on Trailer	2-140	2-475
Removal from Trailer	2-142	2-479
AC Power Distribution System		
	9-30	9-84
AC Power Receptacle		
Install	9-48	9-144
Remove	9-47	9-142
Access Cover, Cockpit Floor		
Install	2-80	2-323
Remove	2-79	2-324
Access Doors, Lower, Engine		
Repair		
General Information	4-60	4-268
Major	4-62	4-273
Minor	4-61	4-271
Replacement	4-60.1	4-269
Access Door, Nose - See Nose Access Door		
Access Doors, Cabin Crown		
Install	2-170	2-559
Remove	2-169	2-553
Install GPS Antenna Mount Provision No. 2 Cabin Crown (With 71)	2-170.2	2-563
Fabrication of Fairing Template for GPS Antenna	2-170.3	2-568
Tunnel Cover, Struts and Clevis		
Adjust	2-169.2	2-557
Install	2-169.3	2-558
Remove	2-169.1	2-556

	Task	Page
Access Panel, Forward Landing Gear		
Install (Left Side) (Without 82)	2-179	2-591
Install (Left Side) (With 82)	2-179.1	2-593
Install (Right Side)	2-181	2-598
Prepare for Installation	2-178.2	2-588
Remove (Left Side) (Without 82)	2-178	2-582
Remove (Left Side) (With 82)	2-178.1	2-585
Remove (Right Side)	2-180	2-595
Access Panels		
Close	2-2	2-8
Inspect for Chafing	2-2.1	2-11
Open	2-2	2-8
Accumulator, Brake, Emergency - See Brake Accumulator, Emergency		
Accumulator, APU Start		
Install	7-149	7-664
Remove	7-148	7-657
Service	1-64	1-245
Accumulator Components, APU Start		
Air Charging Valve		
Install	7-147.2	7-655
Remove	7-147.1	7-652
Mounting Plate		
Replace	7-148.2	7-662
Pressure Gauge		
Install	7-147.2	7-655
Remove	7-147.1	7-652
Transfer Tubes		
Replace	7-148.1	7-659
Accumulator 08-8421-020		
Assembly	7-242.1	7-908
Disassembly	7-241.1	7-901
Inspect	7-241.1	7-901
Accumulator HP1323100, APU Start Module		
Assemble (AVIM)	7-175	7-726
Disassemble (AVIM)	7-173	7-719
Inspect (AVIM)	7-173	7-719
Install	7-178	7-740
Remove	7-172	7-717
Test (AVIM)	7-177	7-734

	Task	Page
Service	1-65	1-249
Accumulator 60910, APU Start Module		
Assemble (AVIM)	7-176	7-732
Disassemble and Inspect (AVIM)	7-174	7-724
Install	7-178	7-740
Remove	7-172	7-717
Test (AVIM)	7-177	7-734
Service	1-65	1-249
Accumulator, Flight Control - See Power Control Module Hydraulic Flight Control (Components)		
Accumulator, Power Control Module - See Power Control Module Accumulator		
Accumulator, Power Steering/Swivel Lock - See Power Steering/Swivel Lock Module Accumulator		
Accumulator, Utility		
Install	7-218.2	7-833
Remove	7-218.1	7-831
Accumulator, Wheel Brake - See Brake Accumulator, Emergency		
Accumulator Relief Valve, Utility		
Install	7-218.4	7-837
Remove	7-218.3	7-835
Acoustic Blankets, Cabin		
Install	2-210	2-751
Remove	2-208	2-744
Acoustic Blankets		
Clean	2-106	2-384
Repair	2-209	2-750
Acoustic Blankets, Cockpit		
Install	2-108	2-391
Remove	2-107	2-385
Actuator, Bleed Band		
Install	4-87	4-339
Remove	4-86	4-337
Actuator, Gas Producer (Without 74)		
Install	4-109	4-394
Remove	4-108	4-392
Actuator, LCT		
Check Shaft Rotation	11-205	11-815
Install (Forward)	11-206	11-821
Install (Aft)	11-221	11-865
Remove (Forward)	11-202	11-807
Remove (Aft)	11-218	11-860

	Task	Page
Replace Motor	11-205.2	11-819
Replace Variable Resistor (AVIM)	11-205.1	11-816
Rig	11-40	11-155
Rod End Bearing - See Actuator Rod End Bearing, LCT		
Actuator, Lower Control, Integrated (ILCA) - See Integrated Lower Control Actuator		
Actuator, Power Turbine (Without 74)		
Install	4-139	4-452
Remove	4-138	4-450
Actuator (Converter), Windshield Wiper		
Install	12-49	12-109
Remove	12-48	12-107
Actuator Cylinder, Extensible Link - See Extensible Link Actuator Cylinder		
Actuator Cylinder, Swivel Lock - See Swivel Lock Actuator Cylinder		
Actuator Motor, Cargo Door - See Cargo Door Actuator Motor		
Actuator Rod End Bearing, LCT		
Clean	11-2	11-8
Check	11-15	11-60
Inspect (Installed)	11-9	11-42
Inspect (Removed)	11-8	11-40
Install	11-220	11-863
Remove	11-219	11-862
Rig	11-40	11-155
Adapter Assembly, Aft Transmission		
Install	6-25	6-71
Remove	6-23	6-68
Adapter Assembly, Combining Transmission		
Aft Output Shaft		
Install	6-24	6-69
Remove	6-22	6-67
Forward Output Shaft		
Install	6-9	6-27
Remove	6-6	6-22
Adapter Assembly, Forward Transmission		
Inspect	6-7	6-23
Install	6-8	6-25
Remove	6-5	6-21
Adapter, Dynamic Absorber		
Installation on Trailer	2-140	2-475
Removal from Trailer	2-142	2-479

	Task	Page
Adapter, Pressure Refueling		
Install	10-88	10-411
Remove	10-87	10-403
Adapter, Static Port		
Install	8-34	8-113
Remove	8-33	8-111
Adapter, Tiedown, 5,000 Pound, Cabin Floor - See Tiedown Adapter, 5,000 Pound, Cabin Floor		
Adapter, Tiedown, 10,000 Pound, Cabin Floor - See Tiedown Adapter, 10,000 Pound, Cabin Floor		
Adapters, Tiedown, Ramp - See Tiedown Adapters, Ramp		
Adhesive Application Criteria	2-312	2-1114
System No. 1	2-314	2-1116
System No. 2	2-315	2-1117
System No. 4	2-316	2-1118
System No. 5	2-317	2-1120
System No. 6	2-318	2-1121
System No. 10	2-319	2-1122
System No. 11	2-320	2-1123
System No. 12	2-321	2-1124
System No. 13	2-322	2-1125
System No. 14	2-323	2-1127
Adhesive Bonding (General)	2-310	2-1108
Adhesive Bonding (Selection Data)	2-311	2-1109
Adhesive Preparation	5-81.6	5-488
Adjust Stops, First and Second Stage Bellcrank Cumulative	11-52	11-222
Adjust Stops, First and Second Stage Bellcrank Thrust Up Inboard And Yaw Right Outboard	11-52.1	11-229
Advanced Flight Control System (AFCS)	11-268	11-1012
Computer		
Adjust Pressure Transducer	11-276.1	11-1065
Assemble	11-276	11-1058
Disassemble	11-275	11-1052
Install	11-278	11-1148
Remove	11-274	11-1050
Test	11-277	11-1071
Control Panel		
Assemble (AVIM)	11-271	11-1027
Disassemble (AVIM)	11-270	11-1021
Install	11-273	11-1049
Remove	11-269	11-1020
Test, Bench (AVIM)	11-272	11-1033

	Task	Page
Interface Test	11-280	11-1168
Aft Connecting Link, Fuselage - See Connecting Links, Aft Fuselage		
Aft Connecting Link, Left Fuselage - See Connecting Link, Left Aft Fuselage		
Aft Connecting Link, Right Fuselage - See Connecting Link, Aft Right Fuselage		
Aft Connecting Links, Tunnel - See Connecting Links, Aft Tunnel		
Aft Crown Fairing, Pylon - See Pylon Aft Crown Fairing		
Aft Cyclic Trim Indicator - See Cyclic Trim Indicator		
Aft Fairing, Forward Transmission - See Forward Transmission Aft Fairing		
Aft Auxiliary Fuel Tank		
Install	10-31	10-146
Remove	10-28	10-132
Test After Installation	10-32	10-150
Aft Auxiliary Fuel Tank (Components)		
Boost Pump		
Remove	10-79	10-373
Install	10-80	10-377
Cell		
Install	10-30	10-141
Remove	10-29	10-136
Fuel Lines And Wiring		
Install	10-78	10-368
Remove	10-77	10-364
Shutoff Valve, Fuel Level		
Install	10-82	10-386
Remove	10-81	10-381
Vent Assembly		
Install	10-66	10-326
Remove	10-65	10-321
Vent Valve		
Install	10-84	10-395
Remove	10-83	10-392
Aft Fuselage Bellcrank (STA 482.00, Aft Side) - See Bellcrank, Aft Fuselage (STA 482.00, Aft Side)		
Aft Fuselage Bellcrank (STA 482.00, Forward Side) - See Bellcrank, Aft Fuselage (STA 482.00, Forward Side)		
Aft Fuselage Idler Bellcrank - See Idler Bellcrank, Aft Fuselage		
Aft Landing Gear		
Assemble	3-31	3-78
Bearing Inspection	3-33	3-85
Convert	3-28	3-71

	Task	Page
Description	3-1	3-2
Disassemble	3-30	3-75
Install	3-32	3-81
Lubricate	1-88	1-318
Remove	3-27	3-67
Service		
Air	1-72	1-272
Hydraulic Fluid	1-70	1-265
Aft Landing Gear Components		
Axle - See Axle, Aft Lubrication Fitting		
Install	3-38.2	3-95
Remove	3-38.1	3-93
Proximity Switch Assembly - See Proximity Switch Assembly, Aft Landing Gear		
Swivel Housing - See Swivel Housing, Aft Landing Gear		
Swivel Lock		
Install	3-68	3-181
Remove	3-67	3-180
Swivel Lock Actuator Cylinder - See Swivel Lock Actuator Cylinder, Aft Landing Gear		
Wheel and Tire Assembly		
Install	3-12.1	3-39
Remove	3-7.1	3-25
Aft LCT Actuator Rigging - See Rigging of Forward and Aft LCT Actuator		
Aft LCT Link - See Link Aft LCT		
Aft LCT Yoke - See Yoke Aft LCT		
Aft Engine Mounts - See Mounts, Engine Aft		
Aft Pylon - See Pylon, Aft		
Aft Rotary-Wing Blades Rigging - See Rotary-Wing Aft Blades		
Aft Rotor Shaft - See Drive Shaft, Aft Rotary-Wing		
Aft Swashplate - See Swashplates		
Aft Swashplate and Servocylinders Rigging - See Rig Procedures - Swashplate and Servocylinders		
Aft Transamission - See Transmission Aft		
Agent Switch, Fire Extinguisher		
Install	12-20	12-54
Remove	12-19	12-52
Air Diffusers, Nose Enclosure		
Install	13-33	13-107
Remove	13-32	13-105

	Task	Page
Air Outlet Duct, Cockpit		
Install	13-31	13-103
Remove	13-30	13-101
Air Pressure Switch, Heater		
Install	13-53	13-159
Remove	13-52	13-158
Air Valve, Forward Landing Gear		
Install	3-22	3-62
Remove	3-21	3-61
Air Valve Support Bracket, Forward Landing Gear		
Install	3-20	3-60
Remove	3-19	3-59
Aircraft Inventory Master Guide Task		
	1-109	1-391
Airframe Description		
	2-1	2-2
Airspeed Indicator		
Install	8-91	8-288
Remove	8-90	8-286
Airspeed Indicator Restrictor		
Adjust	8-37	8-119
Replace	8-36	8-118
Test	8-35	8-116
Airspeed Transducer Adjustment		
	11-276.1	11-1069
Alkaline Exposure, Special Finish Surfaces		
	2-354	2-1237
Altimeter, AIMS		
Install	8-91	8-288
Remove	8-90	8-286
Altimeter, Barometric		
Install	8-91	8-288
Remove	8-90	8-286
Test	8-38	8-122
Altimeter (ID-1917/APN-209), Radar, Copilot		
Install	8-91	8-288
Remove	8-90	8-286
Repair	8-53	8-150
Test	8-54	8-151
Altimeter (RT-1115()/APN-209), Radar, Pilot		
Install	8-91	8-288
Remove	8-90	8-286
Repair	8-51	8-148
Test	8-52	8-149

	Task	Page
Altitude Pressure Transducer Adjustment, Barometric	11-276.1	11-1069
Aluminum Alloy Parts, Finish (Inorganic Surface Treatment) - See Finish Aluminum Alloy Parts (Inorganic Surface Treatment)		
Aluminum Tubing Repair	2-366	2-1254
Anchor Line, Paratroop - See Paratroop and Cargo Drop Equipment		
Anti-Chafing Tape Application	2-337	2-1184
Anticollision Light		
Assemble (AVIM)	9-89	9-290
Disassemble (AVIM)	9-88	9-285
Inspect	9-86	9-283
Install	9-91	9-298
Remove	9-87	9-284
Test (AVIM)	9-90	9-297
ANTI-ICE Overhead Panel		
Install (With 17)	9-98.2	9-329
Install (Without 17)	9-100	9-388
Remove (With 17)	9-98.1	9-314
Remove (Without 17)	9-99	9-353
Anti-Icing, Windshield	12-1	12-2
Test Element	12-2	12-6
Appendix		
A - References		A-1
B - MAC		B-1
C - Aircraft Inventory - See Inventory, Aircraft		
D - Expendable Supplies and Materials - See Expendable Materials		
E - Field Manufactured Items		E-1
F - Wiring Diagrams - See TM 55-1520-240-T		
G - Weight and Balance		G-1
H - Storage of Aircraft - See Storage		
J - Torque Limits - See Torque Limits		
K - Making Information - See Finishing Instructions		K-1
Application Criteria, Adhesive - See Adhesive Application Criteria		
Application of Adhesive - See Adhesive, Application of		
Application of Polyurethane - See Polyurethane Topcoatings		
APU		
Install	15-4	15-17
Preserve	15-2	15-6
Remove	15-3	15-8
Service	1-53	1-207

	Task	Page
APU Components		
Electronic Control Unit		
Install	9-164	9-650
Remove	9-163	9-649
Exhaust Duct Closure		
Install	15-9	15-42
Remove	15-8	15-41
Fuel Boost Pump		
Install	10-98	10-458
Remove	10-97	10-455
Fuel Shutoff Manual Valve		
Install	10-102	10-466
Remove	10-101	10-465
Fuel Solenoid Valve		
Install	10-100	10-463
Remove	10-99	10-461
Generator		
Install	9-34	9-108
Remove	9-33	9-105
Generator Contactor		
Install	9-52	9-152
Remove	9-51	9-150
Generator Current Transformer, Aft		
Install	9-42	9-130
Remove	9-41	9-127
Generator Current Transformer, Forward		
Install	9-44	9-134
Remove	9-43	9-132
Links, Connecting, Aft Mount		
Inspect	15-5	15-26
Install	15-7	15-32
Remove	15-6	15-28
Motor Pump - See Motor Pump, APU		
Mounts - See Mounts, APU		
Power Application	1-36	1-128
Start Accumulator - See Accumulator, APU Start		
Start Module - See Module, APU Start		
Start Module Accumulator - See Accumulator, APU Start Module		
Supports		

	Task	Page
Repair Lateral (AVIM)	2-278	2-952
Repair Upper Mont (AVIM)	2-277	2-951
Arm And Bellcrank Finish Repair, Control	11-13	11-50
Arms And Bellcrank Controls Repair	11-12	11-48
Arm, Control, Tunnel - See Tunnel Control Arms		
Arm, Pitch - See Pitch Arm		
Arm, Roll - See Roll Arm		
Arm, Thrust - See Thrust Arm		
Arm, Yaw - See Yaw Arm		
Arm, Windshield Wiper - See Windshield Wiper System		
Armor, Seat, Pilot and Copilot	16-67	16-264
Back Armor Panel		
Install	16-73	16-278
Remove	16-72	16-274
Back Armor Top Bracket		
Install	16-71	16-272
Remove	16-70	16-270
Bottom Panel, Aft		
Install	16-77	16-291
Remove	16-76	16-289
Bottom Panel, Forward		
Install	16-75	16-286
Remove	16-74	16-283
Check Clearance	16-83	16-303
Inspect	16-82	16-301
Panel Assembly		
Install	16-68	16-266
Remove	16-69	16-268
Shoulder Panel		
Install	16-81	16-299
Remove	16-80	16-297
Arms, Drive, Lower - See Drive Arms, Lower		
Arms, Drive, Upper - See Drive Arms, Upper		
Artificial Feel Forces Check	11-34	11-121
Attitude Indicator - See Indicator, Attitude		
Authority of Substitution	1-7	1-2
Auxiliary Fuel Pump Pressure Switch		
Install	10-86	10-401

Remove	10-85	10-399
Auxiliary Fuel Tank - See Aft or Forward Fuel Tank		
Auxiliary Power Unit - See APU		
Avionics Cooling Fan		
Install	9-59	9-163
Remove	9-55	9-161
Axle, Aft Landing Gear		
Inspect	3-13	3-49
Install	3-35	3-88
Remove	3-34	3-86
Axle, Forward Landing Gear		
Inspect	3-13	3-49
Install	3-15	3-52
Remove	3-14	3-50
B		
Backing Boards, End		
Install	2-190.2	2-690
Remove	2-190.1	2-689
Backing Boards, Inboard		
Install	2-190	2-687
Remove	2-189	2-686
Backing Boards, Outboard		
Install	2-190.2	2-690
Remove	2-190.1	2-689
Balance Spring, Pitch, Roll, and Yaw		
Adjust (Pitch and Roll)	11-137	11-599
Adjust (Yaw)	11-136	11-597
Install	11-135	11-596
Remove	11-134	11-593
Balance Spring, Thrust		
Adjust	11-133	11-591
Install	11-132	11-590
Remove	11-131	11-587
Balance Spring Bracket, Pitch		
Install	11-134.2	11-595
Remove	11-134.1	11-594
Balance Spring Bracket, Thrust		
Install	11-131.2	11-589
Remove	11-131.1	11-588

	Task	Page
Balancing, Rotary-Wing Blades - See Tracking and Balancing, Rotary-Wing Blades		
Ball and Slider Swashplate Travel Check	11-41	11-157
Ball Spherical Bearing Friction Check, Swashplate	5-114	5-641
Barometric Altimeter		
Install	8-91	8-288
Remove	8-90	8-286
Test	8-38	8-122
Barometric Altitude Pressure Transducer Adjustment	11-276.1	11-1065
Batteries, Emergency Exit Lights		
Charge	17-7	17-19
Install	17-6	17-15
Remove	17-5	17-12
Battery		
Connect	1-39	1-136
Disconnect	1-39	1-136
Inspect	9-24	9-68
Install	9-27	9-79
Remove	9-25	9-69
Repair (AVIM)	9-26	9-78
Battery Cable		
Install	9-25.3	9-76
Remove	9-25.1	9-70
Repair and Test	9-25.2	9-72
Battery Charger		
Install	9-29	9-82
Remove	9-28	9-81
Battery Relay		
Install	9-21	9-63
Remove	9-20	9-61
Beam and Bearings, Support, Center Hook		
Install	16-10	16-93
Remove	16-9	16-90
Beams, Repair		
Minor Damage	2-25	2-173
Reparable Damage	2-26	2-174
Bearing Check, Flight Control System Linkage		
Removed	11-8	11-40
Installed	11-9	11-42
Bearing, LCT Actuator, Rod End - See Actuator Rod End Bearing, LCT		

Bearing, LCT Link Lower Fitting - See Link, LCT Lower Fitting Bearing

Bearing, LCT Link Rod End

Check, Looseness	11-6.2	11-22
Clean	11-2	11-8
Inspection, Bearing (Installed)	11-9	11-42
Inspection, Bearing (Removed)	11-8	11-40
Install	11-209	11-829
Remove	11-208	11-827
Repair	11-14	11-53

Bearing, Linear Transducer End Fitting - See Transducer Linear End Fitting Bearing

Bearing, Linear Transducer Rod End - See Transducer Linear Rod End Bearing

Bearing, Pivoting and Swiveling Servocylinders - See Pivoting and Swiveling Servocylinders

Bearings, Horizontal Hinge Pin

Inspect	5-45	5-193
Install	5-46	5-197
Remove	5-44	5-187

Bearings, Shock Absorber Rod End

Install	5-88.2	5-535
Remove	5-88.1	5-534

Bearings, Vertical Hinge Pin

Inspect	5-37	5-166
Install	5-39	5-170
Remove	5-36	5-163
Rotate	5-38	5-168

Bearings, Wheel, Forward Landing Gear - See Wheel Bearings, Forward Landing Gear

Bearings, Yoke Aft LCT - See Yoke Bearing Aft LCT

Bearings, Yoke Forward LCT - See Yoke Bearing Forward LCT

Bellcrank, Aft Fuselage (STA 482.00)

Clean	11-2	11-8
Inspect (Corrosion)	11-11	11-47
Repair of Finish	11-13	11-50
Repair (General)	11-12	11-48
Rig	11-57	11-259

Bellcrank, Aft Fuselage (STA 482.00)

Install (Aft Side)	11-251	11-972
Install (Forward Side)	11-249	11-965
Remove (Aft Side)	11-250	11-969
Remove (Forward Side)	11-248	11-963

Bellcrank, Forward Upper Left - See Forward Left Upper Bellcrank

	Task	Page
Bellcrank, Idler Aft Fuselage - See Idler Bellcrank, Aft Fuselage		
Bellcrank Idler, Pallet Pitch and Roll Rigged - See Rig Procedures, Pallet Pitch and Roll Idler Bellcranks		
Bellcrank Idler, Pallet Thrust and Yaw Rigged - See Rig Procedures, Pallet Thrust and Yaw Idler Bellcranks		
Bellcrank, Intermediate, Pitch - See Pitch Intermediate Bellcranks		
Bellcrank, Intermediate, Roll - See Roll Intermediate Bellcrank		
Bellcrank, Intermediate, Thrust - See Thrust Intermediate Bellcrank		
Bellcrank, Intermediate, Yaw - See Yaw Intermediate Bellcrank		
Bellcrank, Manual Release, Forward and Aft Cargo Hook		
Install	16-40	16-205
Remove	16-37	16-197
Bellcrank, Pitch Idler Control Pallet STA 120.00 - See Control Pallet STA 120.00 Pitch Idler Bellcrank		
Bellcrank, Pylon - See Pylon Bellcranks		
Bellcrank And Arm Finish Repair	11-13	11-50
Bellcrank And Control Arms Repair	11-12	11-48
Bellcrank, Roll Idler Control Pallet STA 120.00 - See Control Pallet STA 120.00 Roll Idler Bellcrank		
Bellcrank Support Fittings, STA 482.00		
Install	11-251.2	11-977
Remove	11-251.1	11-976
Belt, Safety, Pilot or Copilot - See Safety Belt Pilot or Copilot		
Blackout Curtain, NVG		
Install	2-108.2	2-401
Remove	2-108.1	2-399
Blade, Windshield Wiper		
Inspect Parts	12-40	12-93
Install	12-36	12-85
Remove	12-35	12-84
Blades, Aft Rotary-Wing, Rigging	11-58	11-269
Blades, Rotary-Wing Balancing - Refer To TM 1-6625-724-13&P		
Blades, Rotary-Wing		
Clean	5-63	5-274
Description	5-62	5-270
Inspection After Extreme Flapping	5-63.3	5-282
Inspection After Lightning Strike	5-63.2	5-280
Inspection, Serviceability	5-63.1	5-276
Install	5-84	5-510
Place In Service	5-83	5-509
Prepare For Storage	5-65	5-292
Remove	5-64	5-284

	Task	Page
Delamination	5-67.3	5-350
Erosion Cap, Replace (AVIM)	5-66	5-294
Erosion Cap, Unbonding	5-66.1	5-305
Fairing, Double Skin	5-70	5-387
Fairing, Foam Filler	5-69.1	5-378
Fairing, Single Skin, Full Depth	5-68	5-356
Fairing, Single Skin, Partial Depth	5-69	5-368
Insert, Lightning Protection Jumper Wire		
Install	5-79	5-449
Remove	5-78	5-447
Lighting Protection Jumper Strip Replacement	5-81.3.1	5-478
Lighting Protection Jumper Wire Replacement	5-77.1	5-444
Lighting Protection Strip Unbonding	5-81.3	5-474
Nose Cap Crack	5-66.2	5-310
Nose Cap Unbonding	5-66.1	5-305
Refinish	5-82	5-489
Rib Closure, Inboard, Minor Repair	5-76	5-432
Rib Closure, Outboard, Major Repair	5-77	5-441
Root End Slot Seal	5-66.4	5-324
Shock Absorber Bracket	5-81.1	5-458
Shock Absorber Bracket Windings	5-81.2	5-466
Skin Damage	5-67.2	5-342
Spar, Minor Damage	5-67	5-329
Spar, Major Damage	5-67.1	5-332
Tip Seal, Minor	5-76	5-432
Tip Weight Adjustment	5-82.1	5-492
Titanium Nose Cap	5-66.3	5-320
Trailing Edge, Minor Damage	5-71	5-400
Trailing Edge, Major Damage (AVIM)	5-72	5-404
Trim Tab	5-75	5-423
Wire Mesh Corrosion	5-81.4	5-484
Tracking - See Tracking and Balancing, Rotary-Wing Blades		
Blades, Rotary-Wing (Components)		
Tiedown Receiver		
Install	5-81	5-455
Remove	5-80	5-453
Tip Cover		
Install	5-74	5-421
Remove	5-73	5-419

	Task	Page
Tip End Cap Replacement	5-76.1	5-439
Trim Tab		
Adjust Angle	5-75.1	5-429
Check Angle	5-75.1	5-429
Blankets, Acoustic - See Acoustic Blankets		
Bleed Band		
Install	4-85	4-335
Remove	4-84	4-334
Bleed Band Actuator		
Install	4-87	4-339
Remove	4-86	4-337
Bleed/Relief Valve, Flight Control Reservoir/Cooler - See Flight Control Reservoir/Cooler Bleed/Relief Valve		
Bleed/Relief Valve, Utility Reservoir/Cooler		
Install	7-216	7-819
Remove	7-213	7-810
Bleeding, Engine Fuel Control (Without 74)	10-122	10-561
Bleeding, Flight Control Hydraulic System	7-16	7-97
Bleeding, Flight Control Hydraulic System (Without External Power)	7-16.2	7-125
Bleeding, Fuel System	10-121	10-550
Bleeding, Utility Hydraulic System (Using External Power)		
APU Pump/Motor	7-336	7-1233
Cargo Hook, Center	7-337	7-1241
Cargo Ramp and Door	7-339	7-1252
Engine Start (Without 74)	7-338	7-1244
Engine Start (With 74)	7-338.1	7-1248
Power Steering Actuator	7-332	7-1224
PTU Motor and Pump	7-334	7-1229
Pump	7-336	7-1233
Reservoir/Cooler	7-335	7-1231
Swivel Lock System	7-331	7-1220
Wheel Brakes	7-330	7-1214
Winch	7-333	7-1226
Bleeding, Utility Hydraulic System (Without External Power)		
APU Pump/Motor	7-345	7-1275
Cargo Hook, Center	7-346	7-1283
Cargo Ramp and Door	7-348	7-1292
Engine Start (Without 74)	7-347	7-1286
Engine Start (With 74)	7-347.1	7-1289

	Task	Page
Power Steering Actuator	7-342	7-1266
PTU Motor and Pump	7-344	7-1271
Pump	7-345	7-1275
Reservoir/Cooler	7-345	7-1275
Swivel Lock System	7-341	7-1262
Wheel Brakes	7-340	7-1255
Winch	7-343	7-1268
Blocks, Safety Servocylinder		
Install	11-28	11-95
Remove	11-29	11-97
Blocks, Winch Tackle/Cable		
Install	14-22	14-58
Remove	14-21	14-57
Boards, Backing, Inboard - See Backing Boards, Inboard		
Bolt Hole Standards	2-333	2-1163
Bolts, AN, Installation for AN Rivets	2-328	2-1158
Bolts, AN, Substitute for AN Rivets	2-327	2-1157
Bolts, Self-Retaining/Positive Retention	1-14	1-17
Bolts, Substitution of		
Huck, Hi-Lok, or NAS	2-329	2-1159
Jo-Bolts or V-Bolts	2-330	2-1160
Standard Bolts for Huck Bolts	2-331	2-1161
Bolts, Substitute or Replacement for Screws	2-332	2-1162
Bonding, Adhesive - See Adhesive Bonding		
Bonding Surfaces, Preparation of	2-313	2-1115
Boost Pump and Check Valve, Fuel		
APU		
Install	10-98	10-458
Remove	10-97	10-455
Aft Tank		
Install	10-80	10-377
Remove	10-79	10-373
Forward Tank		
Install Boost Pump	10-70	10-344
Remove Boost Pump	10-69	10-342
Main Tank		
Install Aft	10-54	10-263
Install Forward	10-52	10-254
Remove Aft	10-53	10-259

	Task	Page
Remove Forward	10-51	10-249
Boost Pump, Engine Fuel		
Install (Without 74)	4-18	4-136
Install (With 74)	4-18.1	4-138
Remove (Without 74)	4-17	4-133
Remove (With 74)	4-17.1	4-134
Boost, Pitch Link		
Install	5-135	5-736
Remove	5-134	5-734
Boots, Servocylinder Control Valve - See Servocylinder Control Valve Boots		
Bracket, Air Valve Support - See Air Valve Support Bracket, Forward Landing Gear		
Bracket, Engine Actuator Support (Without 74)		
Install	4-111	4-396
Remove	4-110	4-395
Bracket, Fuel Control Valve Mounting		
Install	10-60	10-301
Remove	10-59	10-298
Bracket, Litter Support		
Install	16-64	16-259
Remove	16-63	16-258
Brackets, Support, Suppressive Fire System - See Support Brackets, Suppressive Fire System		
Brake Accumulator, Emergency		
Assemble (AVIM)	7-242	7-904
Disassemble and Inspect (AVIM)	7-241	7-898
Install	7-244	7-913
Remove	7-240	7-895
Test (AVIM)	7-243	7-910
Service	1-67	1-256
Brake, Magnetic Roll - See Roll Magnetic Brake		
Brake, Magnetic Yaw - See Yaw Magnetic Brake		
Brake Master Cylinder		
Assemble (AVIM)	7-227	7-852
Disassemble (AVIM)	7-226	7-847
Inspect (AVIM)	7-226	7-847
Install (Outboard)	7-229	7-867
Install (Inboard)	7-230	7-869
Remove (Outboard)	7-224	7-843
Remove (Inboard)	7-225	7-845
Test (AVIM)	7-228	7-856

	Task	Page
Brake Transfer Valve		
Assemble (AVIM)	7-234	7-878
Disassemble (AVIM)	7-232	7-874
Inspect (AVIM)	7-233	7-876
Install	7-236	7-885
Remove	7-231	7-871
Test (AVIM)	7-235	7-880
Brake Valve, Parking		
Adjust	7-239	7-892
Install	7-238	7-890
Remove	7-237	7-887
Brake Valve, Pressure Reducing		
Install	7-246	7-917
Remove	7-245	7-915
Brake Transfer Valve		
Assemble (AVIM)	7-234	7-878
Disassemble (AVIM)	7-232	7-874
Inspect (AVIM)	7-233	7-876
Install	7-236	7-885
Remove	7-231	7-871
Test (AVIM)	7-235	7-880
Brakes, Landing Gear		
Assemble	3-81	3-211
Clean Parts	3-79	3-209
Disassemble	3-78	3-207
Disks		
Install	3-74	3-197
Remove	3-73	3-196
Inspect	3-72	3-194
Inspect Parts	3-80	3-210
Install (Aft)	3-85	3-219
Install (Forward)	3-83	3-214
Linings		
Inspect	3-72	3-194
Install	3-76	3-200
Remove	3-75	3-198
Test, Functional	3-82	3-213
Brushes, Windshield Wiper Motor		

	Task	Page
Replace	12-43	12-97
Buffer Boards, Cabin - See Cabin Buffer Boards		
Bulkhead, STA 95.00, Repair	2-33	2-192
Minor Damage	2-34	2-197
Reparable Damage (AVIM)	2-35	2-200
Bumper, Load Beam, Forward and Aft Cargo Hook		
Install	16-14	16-102
Remove	16-13	16-101
Bumpers, Trunnion, Forward and Aft Cargo Hook		
Install	16-18	16-109
Remove	16-17	16-108
Bulb, Temperature, Utility Reservoir/Cooler		
Install	7-209	7-801
Remove	7-208	7-799
Bushing, Replace (General Information) (AVIM)	11-16	11-61
Bushing, Shock Absorber Bracket		
Replace	5-81.1	5-458
Bushings, Jettisonable Door Sliding Window - See Jettisonable Door Sliding Window Bushings		
Bushings, Standard Use of	2-335	2-1166
Bushings Support Structure, Forward Transmission - See Support Structure, Bushings, Forward Transmission		
Bushing, Yoke Aft LCT - See Yoke Bushings, Aft LCT		
Bushing, Yoke Forward LCT - See Yoke Bushings, Forward LCT		
Bus Tie Relay		
Install	9-15	9-52
Remove	9-14	9-50
Bypass Panels, Engine Air Inlet		
Clean	4-66	4-284
Fastener Replacement	4-68.4	4-296
Install	4-77	4-333
Remove	4-64	4-281
Repair (General Information)	4-67	4-285
Repair (Major Damage) (AVIM)	4-69	4-300
Repair (Minor Damage)	4-68	4-286
C		
Cabin Air Control		
Install	13-45	13-143
Remove	13-44	13-140
Cabin and Ramp Lighting Relays (Without 17)		

	Task	Page
Install	9-117	9-445
Remove	9-116	9-444
Cabin Buffer Boards		
Install	2-218	2-780
Remove	2-217	2-779
Cabin Crown Walkway - See Walkway, Cabin Crown		
Cabin Door		
Minor Repair	2-151	2-503
Repair (AVIM)	2-152	2-506
Cabin Door Coaming		
Minor Repair	2-75	2-315
Repair (AVIM)	2-76	2-317
Repair Lower Forward Corner	2-77	2-319
Cabin Door, Lower		
Install	2-157	2-513
Hinge		
Install	2-154	2-509
Remove	2-153	2-508
Remove	2-149	2-499
Cabin Door, Upper		
Adjust	2-159	2-518
Install	2-158	2-515
Remove	2-150	2-501
Track		
Install	2-156	2-512
Remove	2-155	2-511
Cabin Ducting		
Install	13-39	13-125
Remove	13-38	13-120
Cabin Equipment Support Structure		
Major Damage (AVIM), Repair	2-168	2-552
Repair	2-166	2-537
Cabin Escape Hatch, Forward - See Escape Hatch, Forward Cabin		
Cabin Floor Panel		
Install	2-207	2-741
Remove	2-204	2-733
Cabin Floor Tiedown, 10,000 Pound (With 19)		
Install	2-237.2	2-817
Remove	2-237.1	2-815

	Task	Page
Cabin Floor Tiedown, 10,000 Pound (Without 19)		
Install	2-237	2-813
Remove	2-236	2-812
Cabin/Ramp Dome Light		
Install	9-115	9-441
Lamp Replacement	9-113	9-438
Remove	9-114	9-439
Cabin Temperature Selector		
Install	13-47	13-148
Remove	13-46	13-146
Cabin Thermostat		
Install	13-61	13-172
Remove	13-60	13-171
Cabin Utility Receptacle, DC - See DC Cabin Utility Receptacle		
Cabin Window 114S2721-5 Seal Replacement	2-165.2	2-529
Cabin Window 173S2904-3 and 1560-CH47-944 Seal Replacement	2-165.3	2-532
Cabin Windows		
Install	2-165.4	2-535
Remove	2-165.1	2-528
Cable Assembly, Engine Electrical (Without 74)		
Install	4-48	4-243
Remove	4-47	4-242
Repair	4-11.3	4-82
Test	4-11.2	4-79
Cable, Battery - See Battery Cable		
Cable Cutter, Winch		
Clean	14-16	14-49
Inspect	14-16	14-49
Install	14-17	14-51
Remove	14-15	14-47
Service	1-75	1-280
Cable, External Manual Release, Forward and Aft Cargo Hook		
Install	16-33	16-180
Remove	16-32	16-178
Cable, Interior Manual Release, Forward and Aft Cargo Hook		
Install	16-35	16-186
Remove	16-34	16-183
Cable, Winch		

	Task	Page
Clean and Inspect	14-2	14-8
Install (AVIM)	14-11	14-39
Remove (AVIM)	14-10	14-35
Canvas and Webbing Repair	2-365	2-1262
Cap, Horizontal Hinge Pin Bearing		
Install	5-41	5-179
Remove	5-40	5-174
Carbon and Low Alloy Steels, Finish		
(Inorganic Surface Treatment) - See Finish Carbon		
And Low Alloy Steels (Inorganic Surface Treatment)		
Cargo Door		
Adjust	2-272	2-931
Body and Receiver Set		
Install	2-264	2-918
Remove	2-263	2-916
Install	2-271	2-930
Ramp Panel (Escape Hatch)		
Install	2-257	2-898
Remove	2-256	2-897
Release Assembly		
Adjust	2-273	2-938
Functional Test	2-274	2-939
Install	2-270	2-929
Remove	2-269	2-928
Remove	2-260	2-906
Track Support		
Install	2-262	2-909
Remove	2-261	2-907
Cargo Door Actuator Motor		
Assemble (AVIM)	7-287	7-1070
Disassemble and Inspect (AVIM)	7-286	7-1068
Install	7-289	7-1075
Remove	7-285	7-1066
Test (AVIM)	7-288	7-1073
Cargo Door Chain and Wire Rope		
Assemble	2-267	2-924
Disassemble	2-266	2-923
Install	2-268	2-925
Remove	2-265	2-920

	Task	Page
Cargo Door Pressure Actuating Valve		
Install	7-284	7-1064
Remove	7-283	7-1049
Cargo Door Sequence Valve		
Adjust	7-282	7-1046
Assemble (AVIM)	7-279	7-1036
Disassemble (AVIM)	7-276	7-1028
Inspect (AVIM)	7-277	7-1031
Install	7-281	7-1044
Remove	7-275	7-1026
Repair	7-278	7-1034
Test	7-280	7-1039
Cargo Handling System	14-1	14-2
Cargo Hook, Center		
Assemble	16-7	16-51
Disassemble	16-5	16-36
Inspection of Parts	16-6	16-47
Install	16-8	16-75
Release Mechanism		
Inspect and Relatch	16-3	16-12
Remove	16-4	16-32
Switches		
Adjust (AVIM)	16-72	16-274
Test (AVIM)	16-71	16-272
Cargo Hook, Fwd and Aft		
Assemble (AVIM)	16-27	16-140
Bumper, Load Beam		
Install	16-14	16-102
Remove	16-13	16-101
Bumpers, Trunnion		
Install	16-18	16-109
Remove	16-17	16-108
Cover and Wire Harness, Solenoid		
Install	16-16	16-105
Remove	16-15	16-103
Disassemble and Inspect (AVIM)	16-24	16-120
Inserts, Threaded		
Install (AVIM)	16-26	16-134
Remove (AVIM)	16-25	16-132

	Task	Page
Inspect	16-11	16-95
Install	16-31	16-170
Keeper		
Install	16-22	16-113
Remove	16-21	16-112
Remove	16-23	16-114
Switches		
Adjust (AVIM)	16-28	16-153
Test		
Functional (AVIM)	16-29	16-160
Watertightness	16-12	16-98
Watertightness	16-30	16-167
Window, Inspection		
Install	16-20	16-111
Remove	16-19	16-110
Cargo Ramp - See Ramp, Cargo		
Cargo Ramp Extension		
Assemble	2-243	2-831
Disassemble	2-241	2-826
Hinge		
Install	2-240	2-823
Remove	2-239	2-821
Install	2-244	2-833
Remove	2-238	2-819
Repair	2-242	2-827
Cartridge (Squib), Fire Extinguisher 892868-02		
Install	12-31	12-73
Remove	12-29	12-69
Cartridge (Squib), Fire Extinguisher 30402103		
Install	12-30	12-71
Remove	12-28	12-67
Caution Lights Switch Panel		
Install	9-133	9-534
Remove	9-132	9-533
Cell, Fuel		
Aft Tank		
Install	10-30	10-141
Remove	10-29	10-136
Cleaning	10-8	10-47

	Task	Page
Damage Classification and		
Repair Limits	10-10	10-49
Forward Tank		
Install	10-25	10-113
Remove	10-24	10-106
Inspect Before installation	10-19	10-72
Main Tank		
Install	10-20	10-78
Remove	10-7	10-43
Precautionary Criteria	10-9	10-48
Preservicing	10-18	10-71
Repair (Inner Liner)	10-15	10-57
Repair (Exterior Plies)	10-12	10-53
Repair (Outer Coating)	10-11	10-51
Test		
Chemical	10-16	10-65
Soap Suds	10-17	10-68
Center Cargo Hook - See Cargo Hook, Center		
Center Windshield, Mixed Installation		
Install	2-53	2-248
Remove	2-52	2-246
Centrifugal Droop Stops - See Droop Stops, Centrifugal		
Chain and Wire Rope, Cargo Door - See Cargo Door Chain and Wire Rope		
Chains, Winch Clutch and Roller		
Clean and Inspect (AVIM)	14-6	14-27
Install (AVIM)	14-8	14-30
Remove (AVIM)	14-5	14-25
Charger, Battery - See Battery Charger		
Check and Depressurizing Valve, APU Start Module		
Install	7-184	7-751
Remove	7-183	7-749
Check for Leaks, Windshield or Window	2-61	2-267
Check Valve, Engine Fuel Line		
Install	10-104	10-469
Remove	10-103	10-467
Check Valve Fitting, Fuel Dual		
Install	10-96	10-453
Remove	10-95	10-451

	Task	Page
Check Valve, Fuel Suction Feed		
Install	10-62	10-314
Remove	10-61	10-312
Check Valve, Integrated Lower Control Actuator		
(ILCA) - See Integrated Lower Control Actuator		
(ILCA) Check Valve		
Check Valve, Jet Pump Motive Flow		
Install	10-50	10-247
Remove	10-49	10-245
Check Valve, Power Transfer Unit Module - See Power Transfer Unit Module Check Valve		
Check Valves, Filter, Utility Return Control Module		
Install	7-201	7-785
Remove	7-200	7-783
Check Valves, Utility Pressure Control Module		
Install	7-167	7-701
Remove	7-166	7-699
Check Valve, Swivel Lock Power Steering		
Install	7-296	7-1090
Remove	7-295	7-1088
Check Valve, Transfer Cylinder, Utility Return		
Control Module		
Install	7-203	7-789
Remove	7-202	7-787
Chip Detector		
Aft Rotary-Wing Drive Shaft		
Inspect Plug	6-160	6-554
Install	6-162	6-557
Remove	6-161	6-556
Combining Transmission		
Inspect Plug	6-178	6-584
Install	6-179	6-586
Remove	6-177	6-583
Chip Detector, Engine Accessory Gearbox		
Install	4-22	4-142
Remove	4-21	4-141
Clamp Mounted Instruments - See Instruments		
Clean and Treat Parts, Salt Corroded - See Clean and Treat Salt Corroded Parts		

	Task	Page
Clean Flight Control System	11-2	11-8
Cleaning		
Aluminum (AVIM)	1-83	1-308
Dusty Enviroment	1-85	1-311
Fuselage Exterior	1-76	1-284
Materials, Cleaning	1-80	1-302
Hydraulic Pistons	1-78	1-294
Magnesium Alloy (AVIM)	1-82	1-305
Metal Parts (AVIM)	1-81	1-304
Plastic - Impregnated Glass Cloth	1-77	1-289
Saltwater Landing or Immersion	1-79	1-298
Clearance Check Controls - See Controls Clearance Check		
Clearance Check Procedure Flight Controls - See Control Clearance Procedure		
Clock		
Install	8-93	8-295
Remove	8-92	8-293
Cockpit Aft Floor Panel		
Install	2-84	2-328
Remove	2-83	2-327
Cockpit Air Control		
Install	13-43	13-138
Remove	13-42	13-136
Cockpit Control Assembly (Copilot's)		
Assemble (AVIM)	11-78	11-383
Disassemble	11-76	11-347
Install	11-82	11-429
Remove	11-74	11-328
Rig	11-79	11-408
Cockpit Control Assembly (Pilot's)		
Assemble	11-77	11-359
Disassemble	11-75	11-336
Install	11-81	11-420
Remove	11-73	11-320
Rig	11-80	11-414
Cockpit Control Assembly, Pilot's and Copilot's		
Rig Installed	11-42	11-161
Cockpit Control Assy Rigging - See Cockpit Control Assembly Pilot's or Copilot's		

	Task	Page
Cockpit Control Stick Position Indicator		
Install	11-84	11-442
Remove	11-83	11-438
Rig	11-45	11-192
Cockpit Control Transfer Bellcranks		
Install	11-88	11-467
Remove	11-87	11-462
Rig	11-46	11-193
Cockpit Control Transfer Connecting Links		
Install	11-86	11-451
Remove	11-85	11-447
Cockpit Crown Window Panel		
Install	2-57	2-258
Prepare for installation	2-56	2-256
Remove	2-55	2-254
Cockpit Defrost Control		
Install	13-37	13-116
Remove	13-36	13-113
Cockpit Dome Light		
Install	9-110	9-430
Lamp		
Replace	9-109	9-429
Remove	9-108	9-427
Cockpit Ducting		
Install	13-29	13-98
Remove	13-28	13-94
Cockpit Enclosure, Repair		
Minor Repair	2-36	2-202
Repairable Damage	2-37	2-208
Repairable Damage	2-38	2-209
Cockpit Floor		
Minor Repair	2-74	2-311
Repair	2-78	2-321
Cockpit Forward Floor Covers		
Install	2-82	2-326
Remove	2-81	2-324
Cockpit Rigging Tools		
Install	11-22	11-82
Remove	11-23	11-85

	Task	Page
Cockpit Transfer Bellcranks Rigged - See Cockpit Control Transfer Connecting Links		
Cockpit Travel Quadrant, Pitch, Roll, or Yaw		
Install	11-24	11-88
Remove	11-25	11-91
Cockpit Window Inspection	2-54	2-252
Coin Patch Skin Repair - See Skin Repair, Coin Patch		
Cold Weather Maintenance	1-86	1-313
Collar, Drive - See Drive Collar		
Combined Yaw and Roll Travel Check	11-37	11-139
Combining Transmission - See Transmission Combining		
Compound, Palmer 611, Application of (AVIM) - See Palmer 611 Compound, Application of (AVIM)		
Compass, Overhead Panel		
Install	9-100	9-388
Remove	9-99	9-353
Compass, Magnetic		
Install	8-47	8-143
Install Bracket	8-46.2	8-142
Remove	8-46	8-140
Remove Bracket	8-46.1	8-141
Components, Hydraulic Maintenance Panel		
Install	8-101	8-319
Remove	8-100	8-309
Computer, AFCS No. 1 or No. 2 - See AFCS No. 1 or No. 2 Computer		
Computer, Blade Track and Balance - Refer to TM 1-6625-724-13&P		
Conditioner, Cruise Guide Signal		
Install	8-40	8-126
Remove	8-39	8-125
Cone, Engine Exhaust		
Install	4-90	4-345
Remove	4-88	4-342
Repair	4-89	4-343
Connecting Link, Drag Strut, Engine Mount Fitting		
Inspect (Without 74)	4-41	4-214
Inspect (With 74)	4-41.1	4-217
Install (All)	4-43	4-234
Remove (Without 74)	4-40	4-210
Remove (With 74)	4-40.1	4-212
Repair (All)	4-42	4-220
Connecting Link, Forward, Left, or Right - See Forward Left or Right Connecting Links		

	Task	Page
Connecting Link, Pitch Viscous Damper - See Pitch Viscous Damper Connecting Link		
Connecting Link Rod End Bearings Inspection (Installed)	11-9	11-42
Connecting Link Rod End Bearings Inspection (Removed)	11-8	11-40
Connecting Link, Roll Viscous Damper - See Roll Viscous Damper Connecting Link		
Connecting Link, Servocylinder, Forward or Aft - See Servocylinder Connecting Link, Forward or Aft		
Connecting Link, Thrust Viscous Damper - See Thrust Viscous Damper Connecting Link		
Connecting Link, Yaw Viscous Damper - See Yaw Viscous Damper Connecting Link		
Connecting Links, Aft Fuselage		
Bearing Check		
Bearing Inspection (Installed)	11-9	11-42
Bearing Inspection (Removed)	11-8	11-40
Clean	11-2	11-8
Inspect	11-7	11-36
Install (Left)	11-253	11-980
Install (Right)	11-255	11-983
Install (Tunnel)	11-245	11-953
Looseness Check	11-6.2	11-22
Remove (Left)	11-252	11-979
Remove (Right)	11-254	11-982
Remove (Tunnel)	11-244	11-950
Repair	11-14	11-53
Rig	11-57	11-259
Connecting Links, APU Aft Mount		
Inspect	15-5	15-26
Install	15-7	15-32
Remove	15-6	15-28
Connecting Links, Flight Control System		
Bearing Check	11-15	11-60
Inspect (Installed)	11-9	11-42
Removed	11-8	11-40
Clean	11-2	11-8
Finish Repair	11-14.1	11-55
Inspect	11-7	11-36
Inspect (Stainless Steel)	11-7.1	11-39
Install	11-106	11-530
Friction Check	11-6	11-18
Remove	11-105	11-528
Repair (Aluminum)	11-14	11-53

	Task	Page
Repair (Stainless Steel)	11-14.2	11-58
Connecting Links, ILCA Intermediate - See ILCA Intermediate Connecting Links		
Connecting Links, Intermediate (Pitch, Roll, Yaw or Thrust)		
Bearing Inspection (Installed)	11-9	11-42
Bearing Inspection (Removed)	11-8	11-40
Clean	11-2	11-8
Inspect	11-7	11-36
Install	11-185	11-726
Looseness Check	11-6.2	11-22
Remove	11-184	11-725
Repair	11-14	11-53
Repair (AVIM)	11-178.1	11-708
Connecting Links, LCT		
Bearing Check	11-15	11-60
Installed	11-9	11-42
Removed	11-8	11-40
Clean	11-2	11-8
Inspect	11-7	11-36
Install (Aft)	11-225	11-876
Install (Forward)	11-210	11-832
Looseness Check	11-6.2	11-22
Remove (Aft)	11-222	11-868
Remove (Forward)	11-207	11-824
Repair	11-14	11-53
Connecting Links, Mixing - See Mixing Linkage Connecting Links		
Connecting Links, Pylon, Upper		
Bearing Inspection (Installed)	11-9	11-42
Bearing Inspection (Removed)	11-8	11-40
Install (Left)	11-261	11-995
Install (Right)	11-263	11-999
Looseness Check	11-6	11-18
Remove (Left)	11-260	11-994
Remove (Right)	11-262	11-998
Repair (Aluminum)	11-14	11-53
Rig	11-57	11-259
Connecting Links, Transfer - See Cockpit Control Transfer Connecting Links		
Connecting Links Tunnel		

	Task	Page
Bearing Inspection (Installed)	11-9	11-42
Bearing Inspection (Removed)	11-8	11-40
Binding Check	11-6.1	11-20
Clean	11-2	11-8
Inspect	11-7	11-36
Install (Aft)	11-239	11-929
Install (Center)	11-237	11-922
Install (Forward)	11-235	11-914
Remove (Aft)	11-238	11-927
Remove (Center)	11-236	11-920
Remove (Forward)	11-234	11-912
Repair	11-14	11-53
Rig	11-56	11-255
Connector Contacts, Coaxial, Fuel Quantity System		
Replace	8-82.1	8-263
Console Components		
Install	9-104	9-417
Remove	9-103	9-414
Consumable (Expendable) Materials	1-18	1-38
Contactor, APU Generator		
Install	9-52	9-152
Remove	9-51	9-150
Contactor, Generator		
Install	9-50	9-148
Remove	9-49	9-146
Container, Stowage Cargo Handling		
Install	14-20	14-56
Remove	14-19	14-55
Contamination, Hydraulic System - See Hydraulic System Contamination		
Contamination, Isolating Fuel	10-33	10-160
Control Arm and Bellcrank Finish Repair	11-13	11-50
Control Arm and Bellcrank, Repair	11-12	11-48
Control Box, Gas Producer (Without 74)		
Install	4-107	4-391
Remove	4-106	4-390
Control Box, Power Steering - See Power Steering Control Box		
Control Box, Remote Positioning		
Install	4-128	4-432
Remove	4-127	4-431

	Task	Page
Control Boxes, Windshield Anti-Icing		
Install	12-4	12-4
Remove	12-3	12-10
Control, Engine Condition		
Inspect	4-103	4-387
Install	4-105	4-389
Remove	4-104	4-388
Control, Engine Fuel (Without 74)		
Install	4-16	4-130
Remove	4-15	4-127
Control, Fire Detection		
Install	12-9	12-28
Remove	12-8	12-26
Control, Fire Pull		
Install	12-18	12-49
Lamp Replace	12-14	12-43
Remove	12-15	12-45
Switch and Adapter		
Install	12-17	12-48
Remove	12-16	12-47
Control, Heater Fuel		
Install	13-63	13-175
Remove	13-62	13-173
Control, Inertia Reel, Pilot or Copilot Shoulder Harness - See Inertia Reel, Pilot or Copilot Shoulder Harness, Control		
Control Linkage, Power Turbine - See Linkage, Power Turbine		
Control Looseness Procedure Check	11-6.2	11-22
Control Pallet, STA 95.00		
Insert Inspection	11-88.1	11-478
Insert Replacement	11-90.1	11-483
Install	11-91	11-488
Remove	11-89	11-479
Control, Pallet, STA 95.00 Thrust Idler Bellcrank		
Install	11-96	11-503
Remove	11-95	11-499
Rig	11-48	11-200
Control, Pallet, STA 95.00 Yaw and Thrust Idler Bellcrank Support		
Install	11-102	11-523
Remove	11-101	11-522

	Task	Page
Control Pallet, STA 95.00 Yaw Idler Bellcrank		
Install	11-94	11-495
Remove	11-93	11-493
Rig	11-48	11-200
Control Pallet, STA 120.00		
Install	11-92	11-491
Remove	11-90	11-481
Control Pallet, STA 120.00 Pitch and Roll Idler Bellcrank Support		
Install	11-104	11-526
Remove	11-103	11-525
Control Pallet, STA 120.00 Pitch Idler Bellcrank		
Install	11-100	11-519
Remove	11-99	11-516
Rig	11-49	11-205
Control Pallet, STA 120.00 Roll Idler Bellcrank		
Install	11-98	11-512
Remove	11-97	11-509
Rig	11-49	11-205
Control Panel, Generator - See Generator Control Panel		
Control Pitch Position Indicator Rigged - See Cockpit Control Stick Position Indicator		
Control Pitch Travel - See Pitch Control Travel Checks		
Control Position Transducer (CPT), Pitch - See Transducer, Pitch Control Position		
Control Position Transducer (CPT), Roll or Yaw - See Transducer, Roll or Yaw Control Position		
Control Position Transducer (CPT), Thrust - See Transducer, Thrust Control Position		
Control Relay Box, Heater - See Relay Box, Heater Control		
Control Rig Thrust - See Rig Thrust Control		
Control Roll Travel - See Roll Control Travel		
Control Shutoff Valve Hoist - See Hoist Control Shutoff Valve		
Control Stick Pitch and Roll (Copilot's)		
Install	11-72	11-317
Remove	11-70	11-313
Control Stick Pitch and Roll (Pilot's)		
Install	11-71	11-314
Remove	11-69	11-312
Control Stick Position Indicator - See Cockpit Control Stick Position Indicator		
Control Thrust - See Thrust Control		
Control Thrust (Copilot's) - See Thrust Control (Copilot's)		
Control Thrust Detent - See Thrust Control Detent		
Control Thrust (Pilot's) - See Thrust Control (Pilot's)		

	Task	Page
Control Thrust Travel - See Thrust Control Travel		
Control Unit, Electronic APU - See APU Electronic Control Unit		
Control Valve Boots Servocylinder		
Install	11-197	11-797
Remove	11-196	11-796
Control Valve Friction Check, Servocylinder	11-6	11-18
Control Valve Leakage Check, Servocylinder	7-123.2	7-546
Control Unit, Fuel Quantity Indicating		
Install	8-80	8-214
Remove	8-79	8-213
Control Valve and Mounting Bracket, Fuel		
Install	10-60	10-301
Remove	10-59	10-298
Control Valve, Cargo Ramp - See Ramp Components, Cargo		
Control Valve, Hoist - See Hoist Control Valve		
Control Valve, Power Steering Swivel Lock - See Power Steering/Swivel Lock Control Valve		
Controller, Temperature		
Install	13-59	13-169
Remove	13-58	13-168
Controls Clearance Check	11-5	11-12
Controls Linkage, Rigging Tunnel	11-56	11-255
Controls, Yaw Travel - See Yaw Control Travel		
Converter, Control Unit		
Install	16-91	16-339
Remove	16-90	16-338
Converter, Windshield Wiper		
Install	12-49	12-109
Remove	12-48	12-107
Cooling Fan, Flight Control - See Flight Control Cooling Fan		
Cooling Fan, Utility Hydraulic - See Utility Hydraulic Cooling Fan		
Corfil Filler, Application of	2-339	2-1186
Corrosion Bellcrank		
Inspect	11-11	11-47
Corrosion/Heat Resistant Steels (Inorganic Surface Treatment) - See Finish Corrosion/Heat Resistant Steels (Inorganic Surface Treatment)		
Corrosion Prevention and Treatment	2-343	2-1190
Cotter Pins, Use of	2-334	2-1165
Countermeasures Dispenser System (AN/ALE-47)		
Bonding Check of Electrical Components	16-59.28	16-250.48

	Task	Page
Crew Dispense Switch		
Install	16-59.27	16-250.42
Remove	16-59.26	16-250.46
Digital Control Display Unit (DCDU)		
Install	16-59.3	16-250.13
Remove	16-59.2	16-250.12
Dispenser Assembly		
Install	16-59.17	16-250.34
Remove	16-59.16	16-250.32
Dispenser Assembly Mount		
Install	16-59.19	16-250.38
Remove	16-59.18	16-250.36
Junction Box		
Install	16-59.21	16-250.41
Remove	16-59.20	16-250.40
Landing Gear Bypass Status Panel		
Assemble	16-59.24	16-250.44
Disassemble	16-59.23	16-250.43
Install	16-59.25	16-250.45
Remove	16-59.22	16-250.42
Miscellaneous Control Panel		
Install	16-59.5	16-250.15
Remove	16-59.4	16-250.14
OFP/MDF Uploading Procedures	16-59.29	16-250.49
Payload Module		
Install	16-59.13	16-250.24
Load	16-59.14	16-250.26
Remove	16-59.12	16-250.22
Unload	16-59.15	16-250.30
Programmer		
Install	16-59.7	16-250.17
Remove	16-59.6	16-250.16
Safety Switch		
Install	16-59.11	16-250.21
Remove	16-59.10	16-250.20
Sequencer		
Install	16-59.9	16-250.19
Remove	16-59.8	16-250.18
Stray Voltage Test Procedures	16-59.30	16-250.57

	Task	Page
Coupling and Seal, APU Motor Pump		
Install (AVIM)	7-145	7-645
Remove (AVIM)	7-144	7-643
Coupling and Seal, Flight Control Hydraulic Pumps - See Flight Control Hydraulic Pumps		
Coupling and Seal		
Cover, Access, Cockpit Floor - See Access Cover, Cockpit Floor		
Cover, Engine		
Adjust	4-51	4-253
Assemble	4-58	4-264
Close	4-50	4-250
Disassemble	4-53	4-258
Install	4-59	4-266
Open	4-49	4-246
Remove	4-52	4-256
Crew Dispense Switch - See Countermeasures Dispenser System		
Crew Dispense Switch		
Repair (Damage Requiring Replacement)	4-57	4-263
Repair (General Information)	4-54	4-260
Repair (Major Damage)	4-56	4-262
Repair (Minor Damage)	4-55	4-261
Support Strut - See Support Strut, Engine Cover		
Cover and Wire Harness, Solenoid, Forward and Aft Cargo Hook		
Install	16-16	16-105
Remove	16-15	16-103
Covers, Protective		
CPLT LTG Overhead Panel		
Install (With 17)	9-98.2	9-329
Install (Without 17 and 74)	9-100	9-388
Remove (With 17)	9-98.1	9-314
Remove (Without 17 and 74)	9-99	9-353
CPT - See Control Position Transducer		
Crossfeed Valve, Fuel		
Install	10-114	10-489
Remove	10-113	10-486
Cross Feedback Transducer, Integrated Lower Control Actuator (ILCA) - See Integrated Lower Control Actuator (ILCA) Cross Feedback Transducer		
Crown Fairing, Aft - See Pylon Aft Crown Fairing		
Crown Fairing, Forward - See Pylon Fwd Crown Fairing		
Crown Fairing, Mid - See Pylon Mid Crown Fairing		

	Task	Page
Cruise Guide Indicator		
Install	8-91	8-288
Remove	8-90	8-286
Cruise Guide Signal Conditioner		
Install	8-40	8-126

	Task	Page
Remove	8-39	8-125
Cruise Guide Signal Processor		
Install	8-42	8-128
Remove	8-41	8-127
Cummulative Stops, Adjust	11-52	11-222
Cups and Keys, Fwd and Aft Landing Gear Wheel		
Install	3-10	3-31
Remove	3-9	3-30
Curtain, Blackout, NVG - See Blackout Curtain, NVG		
Cushion, Seat, Pilot, or Copilot - See Seat Cushion, Pilot or Copilot		
Cutout Relay, Roll Erect - See Roll Erect Cutout Relay		
Cutter, Winch Cable - See Cable Cutter		
Cyclic Stick Grip - See Pitch and Roll Control Stick Grip		
Cyclic Trim Indicator		
Install	8-87	8-278
Remove	8-86	8-276
Test	8-43	8-129
Cylinder Actuating Cargo Ramp - See Ramp Cargo Actuating Cylinder		
Cylinder Brake Master - See Brake Master Cylinder		
Cylinder Actuator Swivel Lock - See Swivel Lock Actuator Cylinder		
Cylinder, Transfer, Utility Return Control Module		
Assemble (AVIM)	7-191	7-764
Disassemble and Inspect (AVIM)	7-190	7-762
Install	7-193	7-770
Remove	7-189	7-760
Test (AVIM)	7-192	7-766
D		
Damage Repair, Complete (AVIM)	2-10	2-33
Damage Repair, Composite	2-9	2-32
Damage Repair, Partial	2-8	2-31
Damper, Pitch Viscous - See Viscous Damper, Pitch		
Damper, Roll Viscous - See Viscous Damper, Roll		
Damper, Thrust Viscous - See Viscous Damper, Thrust		
Damper, Yaw Viscous - See Viscous Damper, Yaw		
Dash (Differential Airspeed Hold) Actuator		
Adjust	11-165	11-675
Adjust (AVIM)	11-163.2	11-665
Install	11-164	11-672

	Task	Page
Remove	11-163	11-662
Rig for Hover - See Rig Dash Actuator for Hover		
Dash Actuator Components		
Actuator, Upper/Lower		
Replace	11-163.1	11-663
Dummy Link		
Install	11-26	11-93
Remove	11-27	11-94
Rod End Bearing		
Install	11-163.4	11-670
Remove	11-163.3	11-669
Data Plate, Aft Landing Gear		
Replace (AVIM)	3-65	3-174
DC Cabin Utility Receptacle		
Install	9-7	9-31
Remove	9-6	9-29
DC Electrical System - See Electrical DC System		
DC Power Receptacle		
Install	9-5	9-27
Remove	9-4	9-25
Decals Overcoating, Special Finish	2-355	2-1241
Defrost Valve		
Install	13-27	13-92
Remove	13-26	13-90
Defroster Nozzle, Jettisonable Door Window		
Install	13-35	13-111
Remove	13-34	13-109
Defueling		
With AC Power	10-34	10-168
Without AC Power	10-35	10-176
Defueling Manual Valve		
Install	10-110	10-479
Remove	10-109	10-477
Diffusers, Air, Nose Enclosure		
Install	13-33	13-107
Remove	13-32	13-105
Digital Control Display Unit - See Countermeasures Dispenser System Digital Control Display Unit (DCDU)		
Dimming Resistor, Position Light - See Position Light Dimming Resistor		
Dimming Resistor, Troop Jump Signal - See Troop Jump Signal Dimming Resistor		
Dispenser System, Countermeasures - See Countermeasures Dispenser System		
Dispenser, Flare		
Install	16-50	16-232

	Task	Page
Remove	16-49	16-230
Distribution Panels, Power - See Power Distribution Panels		
Door, Cabin - See Cabin Door		
Door, Cabin, Lower - See Cabin Door, Lower		
Door, Cabin, Upper - See Cabin Door Upper		
Door, Cargo - See Cargo Door		
Door, Cargo Actuator Motor - See Cargo Door Actuator Motor		
Door, Cargo Pressure Actuating Valve - See Cargo Door Pressure Actuating Valve		
Door, Cargo Sequence Valve - See Cargo Door Sequence Valve		
Door, Jettisonable - See Jettisonable Door, Pilot or Copilot		
Door, Nose Access - See Nose Access Door		
Drag Link, Lower - See Lower Drag Link, Aft Landing Gear		
Drag Link, Upper - See Upper Drag Link, Aft Landing Gear		
Drag Strut - See Connecting Link (Drag Strut) Engine Mount Fittings		
Drain Plug, Fuselage - See Fuselage Drain Plug		
Drain Valve, Fuel		
Fuel System		
Install	10-94	10-449
Remove	10-93	10-444
Fuel Tank		
Install	10-40	10-205
Remove	10-39	10-204
Drip Pans, Remove and Install	2-3	2-12
Drive Arms		
Lower		
Assemble (AVIM)	5-110	5-628
Disassemble (AVIM)	5-108	5-625
Inspect (AVIM)	5-109	5-626
Install	5-112	5-635
Remove	5-101	5-613
Upper		
Bearing Replacement	5-107	5-623
Inspect (AVIM)	5-106	5-622
Install	5-112	5-635
Remove	5-101	5-613

	Task	Page
Drive Collar		
Assemble (AVIM)	5-104	5-620
Disassemble (AVIM)	5-102	5-617
Inspect (AVIM)	5-103	5-618
Install	5-111	5-631
Remove	5-100	5-610
Drive Shaft, Aft Rotary-Wing	6-1	6-2
Chip Detector		
Inspect Plug	6-160	6-554
Install	6-162	6-557
Remove	6-161	6-556
Inspect	6-58	6-225
Install Through Cabin	6-63	6-243
Install Through Top of Pylon	6-62	6-239
Oil Filter		
Clean	6-164	6-559
Inspect	6-164	6-559
Install	6-165	6-561
Remove	6-163	6-558
Prepare for Shipment or Storage	6-60	6-233
Remove from Storage	6-61	6-237
Remove Through Cabin	6-57	6-222
Remove Through Top of Pylon	6-56	6-219
Repair	6-59	6-227
Seal, Upper		
Install (AVIM)	6-54	6-211
Remove (AVIM)	6-53	6-209
Slider Shaft		
Install	6-55	6-217
Remove	6-52	6-204
Repair	6-52.1	6-205
Support		
Repair	6-59.1	6-230
■ Drive Shaft, Engine	6-1	6-3
Install	6-32	6-102
Repair	6-31	6-95
Remove	6-30	6-84
Drive Shaft Windshield Wiper		
Install	12-47	12-106

	Task	Page
Remove	12-46	12-105
Drive Shafting		
Adapter Assembly - See Adapter Assembly		
Aft Rotor Shaft - See Aft Rotary-Wing Drive Shaft		
Align Forward Drive Shafting	6-20	6-60
Assemble	6-16	6-48
Disassemble	6-12	6-39
Inspect	6-10	6-29
Mount, Aft		
Inspect	6-13	6-41
Install	6-27	6-74
Remove	6-26	6-73
Mount, Forward		
Inspect	6-13	6-41
Install	6-15	6-45
Remove	6-14	6-42
No. 1 Shaft		
Install	6-17	6-51
Remove	6-2	6-12
No. 2 thru No. 6 Shaft		
Install	6-18	6-54
Remove	6-3	6-15
No. 7 Shaft		
Install	6-19	6-58
Remove	6-4	6-19
No. 8 and No. 9 Shaft (Aft Shafting)		
Install	6-29	6-80
Remove	6-21	6-64
Repair	6-11	6-37
Droop Eliminator Potentiometer - See Engine Droop Eliminator Resistors		
Droop Stops, Centrifugal		
Balancing Arm		
Install	5-59	5-255
Remove	5-58	5-253
Blocks and Supports		
Inspect	5-51	5-231
Install	5-61	5-260
Remove	5-60	5-257
Bolts and Lugs		

	Task	Page
Inspect	5-53	5-238
Functional Check	5-52	5-233
Install	5-55	5-243
Interposer Support Spring Back		
Inspect and Adjust	5-49	5-224
Remove	5-54	5-242
Springs and Balancing Arms		
Inspect	5-50	5-228
Springs and Weights		
Install	5-57	5-250
Remove	5-56	5-247
Droop Stops, Fixed		
Inspect	5-47	5-203
Replace	5-48	5-205
Drum and Level Wind Mechanism, Winch Time (AVIM)	14-7	14-29
Dual Cargo Hook Release Relay Box		
Assemble (AVIM)	9-153	9-620
Disassemble (AVIM)	9-152	9-616
Install	9-154	9-627
Remove	9-151	9-614
Test (AVIM)	9-153.1	9-624
Dual Check Valve Fitting, Fuel		
Install	10-96	10-453
Remove	10-95	10-451
Dual Torquemeter Indicator		
Install	8-89	8-283
Remove	8-88	8-281
Test (AVIM) (Without 74)	8-19	8-61
Duct, Cockpit Air Outlet		
Install	13-31	3-103
Remove	13-30	3-101
Duct, Distributor Air		
Install	13-25	3-88
Remove	13-24	3-86
Duct, Heater Air Inlet		
Install	13-19	3-74
Remove	13-18	3-72
Duct, Heater Transition		
Install	13-23	13-84

	Task	Page
Remove	13-22	13-82
Ducting, Cabin		
Install	13-39	13-125
Remove	13-38	13-120
Ducting, Cockpit		
Install	13-29	13-98
Remove	13-28	13-94
Dummy Link, Dash Actuator - See Dash Actuator Dummy Link		
Dynamic Absorber, Cockpit - See Absorber, Dynamic, Cockpit		
Dynamic Absorber, Nose - See Absorber, Dynamic, Nose		
Dynamic Absorber, Test Box		
Install	2-148	2-502
Remove	2-147	2-497
E		
ELECT Overhead Panel		
Install (With 17)	9-98.2	9-329
Install (Without 17)	9-100	9-388
Remove (With 17)	9-98.1	9-314
Remove (Without 17)	9-99	9-353
Electrical AC System		
Description	9-30	9-84
Theory of Operation	9-30	9-84
Electrical Cable Assembly, Engine (Without 74)		
Inspect and Test	4-11.2	4-79
Install	4-48	4-243
Remove	4-47	4-242
Electrical DC System		
Description	9-1	9-2
Theory of Operation	9-1	9-2
Electrical Power, External, Application of	1-37	1-132
Electronic Control Unit, APU		
Install	9-164	9-650
Remove	9-163	9-649
Element Filter, Utility Return Control Module		
Install	7-195	7-774
Remove	7-194	7-772
Element, Sensing, Fire Detection		
Inspect	12-11	12-32

	Task	Page
Install	12-13	12-38
Remove	12-12	12-33
Test	12-10	12-30
Emergency Brake Accumulator - See Brake Accumulator Emerg		
Emergency Engine Trim Relays (Without 74)		
Install	4-126	4-430
Remove	4-125	4-429
Emergency Equipment	17-1	17-2
Emergency Exit Light - See Light, Emergency Exit		
Emergency Exit Light Batteries		
Charge	17-7	17-19
Install	17-6	17-15
Remove	17-5	17-12
Emergency Exit Light Panel and Pan		
Install	17-10	17-25
Remove	17-9	17-23
Emergency Hook Release Relay Box		
Assemble (AVIM)	9-149	9-602
Disassembly (AVIM)	9-148	9-598
Install	9-150	9-613
Remove	9-147	9-597
Test (AVIM)	9-149.1	9-607
EMERGENCY POWER Overhead Panel (Without 74)		
Install (With 17)	9-98.2	9-329
Install (Without 17)	9-100	9-388
Remove (With 17)	9-98.1	9-314
Remove (Without 17)	9-99	9-353
Emergency Power Light (Indicator) (Without 74)		
Install	8-4	8-22
Lamp Replacemnet	8-5	8-24
Remove	8-3	8-20
Emergency Power Panel (Without 74)		
Assemble (AVIM)	9-99.2	9-367
Disassemble (AVIM)	9-99.1	9-365
Test (AVIM)	9-99.3	9-369
Emergency Power Switches (Without 74)		
Install	8-7	8-26
Remove	8-6	8-25
Engine Air Particle Separator		

	Task	Page
Control Box		
Install	16-106	16-362
Remove	16-105	16-361
Control Panel Components		
Install	16-104	16-359
Remove	16-103	16-358
Install	16-110	16-368
Power Distribution Panel (PDP), Extension Box, and Circuit Breakers		
Install	16-102	16-357
Remove	16-101	16-356
Provisions	16-100	16-354
Remove	16-109	16-365
Remove And Install FOD Screens (EAPS)	16-115	16-376
Replace Bypass Door Actuator (EAPS)	16-123	16-384
Replace Differential Pressure Switch	16-122	16-383
Replace Diffuser Duct (EAPS)	16-118	16-379
Replace Electrical Cable (EAPS)	16-111	16-372
Replace Inlet Tubes	16-108	16-364
Replace Hook Latch	16-117	16-378
Replace Mounting Feet	16-112	16-373
Replace Pin Latch	16-116	16-377
Replace Scavenge Blower Assembly	16-119	16-380
Replace Scavenge Blower Duct	16-121	16-382
Scavenge Blower Impellar		
Inspect, For Wear	16-124	16-385
Replace	16-120	16-381
Shipping And Storage	16-107	16-363
Slide Bearings/Blocks		
Install	16-114	16-375
Remove	16-113	16-374
Troubleshooting	16-125	16-386
Enclosure, Cockpit - See Cockpit Enclosure		
Engine Components - Also See Powerplant		
Accessory Gearbox Chip Detector		
Install (Without 74)	4-22	4-142
Remove (Without 74)	4-21	4-141
Replace (With 74)	4-22.1	4-143
Air Inlet Bypass Panels - See Bypass Panels, Engine Air Inlet		
Air Inlet Screens		

	Task	Page
Adjust	4-63	4-276
Clean	4-66	4-284
Install	4-76	4-330
Remove	4-65	4-282
Repair (General Information)	4-67	4-285
Repair (Major Damage)	4-69	4-300
Repair (Minor Damage)	4-68	4-286
Air Inlet Fairing		
Install (Without 74)	4-75	4-320
Install (With 74)	4-75.1	4-325
Remove (Without 74)	4-74	4-312
Remove (With 74)	4-74.1	4-316
Compressor Cleaning and Preservation (With 74) - See Water Wash, Engine		
Condition Control		
Inspect	4-103	4-387
Install	4-105	4-389
Remove	4-104	4-388
Cover - See Cover, Engine		
Cover Former		
Adjust	4-44	4-237
Install	4-46	4-240
Remove	4-45	4-238
Cushion Replacement, Screen	4-68.3	4-294
Door - See Access Door, Lower, Engine		
Droop Eliminator Resistors (Without 74)		
Adjust	4-118	4-411
Assemble	4-121	4-422
Disassemble	4-120	4-420
Install and Rig	4-122	4-424
Remove	4-119	4-419
Electrical Harness (Without 74)		
Repair	4-11.3	4-82
Test	4-11.2	4-79
Firewall and Engine Cover Former		
Adjust	4-44	4-237
Install	4-46	4-240
Remove	4-45	4-238
Fuel Boost Pump		
Install (Without 74)	4-18	4-136

	Task	Page
Install (With 74)	4-18.1	4-138
Remove (Without 74)	4-17	4-133
Remove (With 74)	4-17.1	4-134
Fuel Control		
Install	4-16	4-130
Remove	4-15	4-127
Fuel Line Check Valve		
Install	10-104	10-469
Remove	10-103	10-467
Fuel Shutoff Valve		
Install	10-112	10-484
Remove	10-111	10-482
Inline Fuel Filter		
Replace	4-19	4-139
Latch Assembly Replacement, Screen	4-68.1	4-287
Latch Replacement, Screen Access Door	4-68.2	4-291
Mounts - See Mounts, Engine		
Oil Pressure Indicator		
Install	8-87	8-278
Remove	8-86	8-276
Test	8-14	8-42
Oil Pressure Transmitter		
Install	8-16	8-48
Remove	8-15	8-43
Oil Temperature Indicator		
Install	8-87	8-278
Remove	8-86	8-276
Test	8-17	8-54
Oil Temperature Transmitter (Bulb)		
Replace	8-18	8-56
Power Turbine Inlet Temperature (PTIT) Wire Harness		
Install	4-14.2	4-126
Remove	4-14.1	4-124
Screens - Air Inlet - See Engine Air Inlet Screens		
Starter		
Install	7-142	7-639

	Task	Page
Remove	7-141	7-636
Trim Relay (Without 74)		
Install	4-124	4-428
Remove	4-123	4-427
Trim Resistors (Without 74)		
Adjust	4-129	4-433
Install	4-131	4-438
Remove	4-130	4-436
Engine Trim Relay		
Install	4-124	4-428
Remove	4-123	4-427
Work Platform		
Install	2-220	2-783
Remove	2-219	2-781
ENG COND Overhead Panel		
Install (With 17 and 74)	9-98.2	9-329
Install (Without 17)	9-100	9-388
Remove (With 17)	9-98.1	9-314
Remove (Without 17 and 74)	9-99	9-353
Engine Emergency Power Indicator (Without 74)		
Install	8-4	8-22
Lamp Replacement	8-5	8-24
Remove	8-3	8-20
Engine Start System	7-135	7-608
Engine Transmission - See Transmission, Engine		
Engine Transmission Fairing		
Install	4-73	4-308
Remove	4-70	4-303
Environmental Maintenance		
Cold	1-86	1-313
Dust	1-85	1-311
Heat	1-84	1-310
Environmental System	13-1	13-2
Equipment Support Structure, Aft Pylon		

	Task	Page
Minor Repair	2-300	2-1023
Repair	2-301	2-1024
Repair (AVIM)	2-302	2-1027
Equipment Improvement Recommendations (EIR)	1-6	1-1
Equipment Support Structure, Cockpit		
Repair	2-71	2-298
Major Damage (AVIM)	2-73	2-304
Minor Damage	2-72	2-303
Erosion Cap, Rotary-Wing Blades	5-66	5-294
Replace (AVIM)	5-66	5-294
Unbonding Repair	5-66.1	5-305
Escape Hatch, Forward Cabin (With and Without 70)		
Install	2-165	2-526
Remove	2-160	2-520
Repair	2-161	2-522
Major Damage (AVIM)	2-163	2-525
Minor Damage	2-162	2-524
Essential DC Bus Relay		
Install	9-23	9-66
Remove	9-22	9-65
ESU (ECU - Electronic Control Unit), APU		
Install	9-164	9-650
Remove	9-163	9-649
Exhaust Cone, Powerplant		
Install	4-90	4-345
Remove	4-88	4-342
Exhaust Pipe, Heater		
Install	13-21	13-79
Remove	13-20	13-77
Expendable (Consumable) Materials	1-18	1-38
EXT LTG Overhead Panel - See Overhead Panel Components		
Extended Range Fuel System II (ERFS II) (With 82)		
ERFS II Cavity Drain		
Install	16-99	16-350
Remove	16-98	16-348

Refueling Hose (With 82)		
Install	10-55.3	10-279
Remove	10-55.2	10-277
Extensible Link, ILCA - See Integrated Lower Actuator Components, Extensible Link		
Extension, Cargo Ramp - See Cargo Ramp Extension		
External Power		
Electric	1-37	1-132
Hydraulic	1-38	1-134
External Power Monitor		
Install	9-38	9-120
Remove	9-37	9-119
External Power Contractor		
Replace	9-38.1	9-121
Extinguisher (Bottle) 30402103, Fire		
Install	12-32	12-75
Install Cartridge	12-30	12-71
Inspect	12-26	12-63
Remove	12-23	12-59
Remove Cartridge	12-28	12-67
Extinguisher (Bottle) 892868-02, Fire		
Install	12-33	12-78
Install Cartridge	12-31	12-73
Inspect	12-27	12-65
Remove	12-24	12-61
Remove Cartridge	12-29	12-69
Extinguisher, Fire, Portable		
Install	17-3	17-8
Remove	17-2	17-6
Extrusions, Minor Damage Removal	2-336	2-1167
F		
Fairing, Aft Crown - See Pylon Aft Crown Fairing		
Fairing, Engine Air Inlet		
Install (Without 74)	4-75	4-320
Install (With 74)	4-75.1	4-325
Remove (Without 74)	4-74	4-312
Remove (With 74)	4-74.1	4-316
Fairing, Engine Transmission		
Install	4-73	4-308
Remove	4-70	4-303

	Task	Page
Repair (Minor Damage)	4-71	4-306
Repair (Major Damage) (AVIM)	4-72	4-307
Fairing, Forward Crown, Pylon - See Pylon Forward Crown Fairing		
Fairing, Forward Transmission - See Forward Transmission Fairing		
Fairing, Mid Crown, Pylon - See Pylon Mid Crown Fairing		
Fairing, Pylon Lower, Hinged - Pylon Lower Hinged Fairing		
Fairing, Trailing Edge - See Trailing Edge Fairing		
Fairing Repair, Rotary-Wing Blade - See Blades, Rotary-Wing		
Fan, Avionics Cooling - See Avionics Cooling Fan		
Fan, Cooling - Flight Control - See Flight Control Cooling Fan		
Fan Cooling Utility Hydraulic - See Utility Hydraulic Cooling Fan		
Fan, Heater		
Assemble (AVIM)	13-15	13-64
Clean Parts (AVIM)	13-14	13-63
Disassemble and Inspect (AVIM)	13-13	13-59
Install	13-17	13-70
Remove	13-12	13-58
Test (AVIM)	13-16	13-68
Fan, Oil Cooler, Aft Transmission - See Oil Cooler Assembly, Aft Transmission		
Fan, Oil Cooler, Combining Transmission - See Oil Cooler Assembly, Combining Transmission		
Fan, Utility Hydraulic Cooling - See Cooling Fan Utility Hydraulic		
FAT (Free Air Temperature) Gauge		
Install	8-96	8-303
Remove	8-94	8-301
Test	8-95	8-302
Feel Forces, Artificial - See Artificial Feel Forces		
Ferry Fuel System Grounding Receptacles Replacement	2-210.1	2-757
Fiberglass Blades - See Blades, Rotary-Wing		
Field Manufacture Items		E-1
Fill Module, Hydraulic System		
Assemble (AVIM)	7-19	7-140
Disassemble and Inspect (AVIM)	7-18	7-135
Install	7-21	7-152
Remove	7-17	7-133
Test (AVIM)	7-20	7-146
Filler, Corfil, Application of	2-339	2-1186
Filler, Oil, Engine		
Install	4-99	4-363

	Task	Page
Remove	4-98	4-361
Filling and Bleeding Flight Control Hydraulic System	7-16	7-97
Filter Bypass Valve, Utility Return Control Module		
Install	7-197	7-778
Remove	7-196	7-776
Filter Check Valve, Power Control Module - See Power Control Module Filter Check Valve		
Filter Element, Power Control Module - See Power Control Module Filter Element		
Filter Element Replacement, Oil		
Aft Transmission		
Auxiliary	6-154	6-539
Main	6-148	6-525
Combining Transmission		
Auxiliary	6-173	6-578
Main	6-171	6-571
Engine Transmission	6-199	6-654
Forward Transmission		
Auxiliary	6-129	6-487
Main	6-123	6-472
Filter Element, Utility Return Control Module - See Element, Filter, Utility Return Control Module		
Filter, Fuel, Engine Inline		
Replace	4-19	4-139
Filter Indicator Switch, Power Control Module - See Power Control Module, Hydraulic Flight Control		
Filter, Oil, Aft Rotor Shaft		
Clean	6-164	6-559
Inspect	6-164	6-559
Install	6-165	6-561
Remove	6-163	6-558
Filter, Pressure Control Module		
Install	7-157	7-682
Remove	7-156	7-680
Filter Relief Valve, Power Control Module - See Power Control Module, Hydraulic Flight Control		
Finishing Instructions		
Aluminum Alloy Parts	2-346	2-1196
Carbon and Low Alloy Steels	2-348	2-1202
Connecting Links (With 26)	11-14.1	11-55
Corrosion/Heat Resistant Steels	2-349	2-1203
Decal Overcoating	2-355	2-1241
Finish Removal (AVIM)		
Interior Structures, Detail or Repair Parts		

	Task	Page
Marking Instructions (Final Finish)	2-352	2-1210
Mating, Dissimilar Metal	2-351	2-1209
Non-Mating, Similar Metal	2-350	2-1204
Magnesium Alloy Parts	2-347	2-1198
Metal Structures Final Finish	2-352	2-1210
Nonmetallic Parts, Organic	2-353	2-1236
Surfaces Exposed to Alkaline	2-354	2-1237
Walkways	2-356	2-1242
Fire Detection and Extinguishing System	12-12	12-33
Fire Detection Control		
Install	12-9	12-28
Remove	12-8	12-26
Fire Detection Sensing Element - See Element, Sensing, Fire Detection		
Fire Emergency Panel Light Plate (With 17)		
Install	8-114	8-368
Remove	8-113	8-367
Fire Extinguisher Agent Switch		
Install	12-20	12-54
Remove	12-19	12-52
Fire Extinguisher (Bottle) 30402103 - See Extinguisher		
Fire Extinguisher (Bottle) 892868-02 - See Extinguisher		
Fire Extinguisher Discharge Nozzle		
Install	12-22	12-57
Remove	12-21	12-56
Fire Pull Control - See Control, Fire Pull		
Fire Extinguisher, Portable - See Extinguisher Fire, Portable		
First Aid Kits	17-1	17-2
First and Second Stage Bellcranks Rigging	11-51	11-216
First Stage Control Rig Pin Damage Removal	11-19	11-76
First Stage Mixing Assembly		
Bushings		
Replace	11-16	11-61
Check - Bearings, Axial Looseness	11-5.1	11-16
Clean - See Clean Flight Control System Remove		
Inspect - Bearings (Installed)	11-9	11-42
Inspect - Bearings (Removed)	11-8	11-40
Inspect - General (Without 38)	11-7	11-36

	Task	Page
Install	11-189	11-752
Remove	11-188	11-747
Repair (Without 38)	11-14	11-53
Rig	11-51	11-216
Fitting, Lubrication - See Lubrication Fitting		
Fixed Droop Stops		
Inspect	5-47	5-203
Replace	5-48	5-205
Flange Mounted Instruments - See Instruments		
Flap, Air Outlet, Butterfly Valve and		
Install	13-41	13-133
Remove	13-40	13-131
Flapping Inspection, Blade	5-63.3	5-282
Flare Dispenser		
Install	16-50	16-232
Remove	16-49	16-230
Flare Dispenser System		
Description	16-48	16-226
Test	16-55	16-240
Theory of Operation	16-48	16-226
Flare Dispenser Relay		
Install	16-59	16-249
Remove	16-58	16-248
Flare Dispenser Timer		
Install	16-57	16-247
Remove	16-56	16-246
Flight Control Bellcrank Support Fittings, STA 482.00 - See Bellcrank Support Fittings, STA 482.00		
Flight Control Cooling Fan		
Install	7-122	7-537
Remove	7-118	7-535
Flight Control and Utility Hydraulic Pump Test	7-26	7-164
Flight Control Hydraulic Pumps		
Coupling and Seal		
Install (AVIM)	7-25	7-162
Remove and Inspect (AVIM)	7-24	7-160
Install Pump No. 1	7-27	7-166
Install Pump No. 2	7-28	7-170
Remove Pump No. 1	7-22	7-154
Remove Pump No. 2	7-23	7-157

	Task	Page
Flight Control Hydraulic System		
Bleeding	7-16	7-97
Description	7-1	7-2
Filling	7-16	7-97
Flushing - See Flushing Procedures - Flight Control Hydraulic System		
Theory of Operation	7-1	7-8
Flight Control Hydraulic System Reservoir Cooler		
Assemble (AVIM)	7-115	7-523
Disassemble (AVIM)	7-114	7-519
Inspect	7-114	7-519
Install	7-117	7-533
Fluid Sampling	7-8.1	7-56
Remove	7-113	7-516
Test	7-116	7-526
Flight Control Hydraulic System Reservoir Cooler Components		
Bleed/Relief Valve		
Install	7-106	7-502
Remove	7-105	7-500
Relief Valve		
Install	7-108	7-506
Remove	7-107	7-504
Remove	7-113	7-516
Temperature Bulb		
Install	7-110	7-510
Remove	7-109	7-508
Temperature Switch		
Install	7-112	7-514
Remove	7-111	7-512
Flight Controls	11-1	11-1
Adjust Stops, First and Second Stage	11-52.1	11-222
Bushing Replacement	11-16	11-61
Clean	11-2	11-8
Clearance Check	11-5	11-12
Description	11-1	11-2
Inspection		
After Removing Damaged Rigging Pin	11-18	11-75
Bearings	11-15	11-60

	Task	Page
Bearings, Bellcrank (Installed)	11-9	11-42
Bearings, Bellcrank (Removed)	11-8	11-40
Bearings, Connectings Link (Installed)	11-9	11-42
Bearings, Connecting Link (Removed)	11-8	11-40
Bellcranks	11-10	11-45
Connecting Links (Losseness Check)	11-7	11-36
Corrosion (Bellcranks)	11-11	11-47
Idler Arms	11-10	11-45
Rod End Bearings (Installed)	11-9	11-42
Rod End Bearings (Removed)	11-8	11-40
Looseness Check, Axial, First and Second Stage Bellcranks	11-5.1	11-16
Looseness Check - Isolation	11-6.3	11-27
Looseness Check - Overall	11-6.2	11-22
Repair		
Bellcranks	11-12	11-48
Connecting Links	11-14	11-53
Control Arms	11-12	11-48
Finish	11-13	11-50
Rig (General Information)	11-4	11-11
Floodlight		
Install	9-106	9-423
Lamp		
Replace	9-107	9-425
Remove	9-105	9-421
Floor, Cockpit - See Cockpit Floor		
Floor Covers, Cockpit Forward - See Cockpit Forward Floor Covers		
Floor Panel, Cockpit Aft - See Cockpit Aft Floor Panel		
Floor Panels, Cabin		
Install	2-207	2-741
Remove	2-204	2-733
Floor Panels, Ramp		
Install	2-249	2-846
Remove	2-247	2-841
Repair	2-248	2-842
Flow Divider, Powerplant Fuel		
Replace	4-20	4-140
Flow Limiter, Power Transfer Unit Module - See Power Transfer Unit Module Flow Limiter		

	Task	Page
Flow Test, Vent System	10-118	10-504
Flushing Procedures		
APU Return Tubing	7-329	7-1206
Cargo Door Motor Tubing	7-326	7-1194
Cargo Hook Pressure Tubing	7-317	7-1135
Cargo Hook Return Tubing	7-318	7-1141
Engine Start Tubing, Pressure	7-315	7-1129
Engine Start Tubing, Return	7-316	7-1132
Flight Control Hydraulic System		
External Supply Lines	7-15	7-92
Prepare for Flushing Pressure Lines	7-9	7-58
Prepare for Flushing Return Lines	7-12	7-75
Prepare System After Flushing Pressure Lines	7-11	7-68
Prepare System After Flushing Return Lines	7-14	7-86
Pressure Lines	7-10	7-64
Return Lines	7-13	7-81
Serious Contamination	7-16.1	7-106
Fuel System, Airframe	7-36	7-190
Fuel System, Engine	10-37	10-193
Ground Service Return Tubing	7-327	7-1187
Ground Test Pump Tubing	7-321	7-1153
Hand Pump Tubing	7-321	7-1153
Hoist Control Pressure Tubing	7-319	7-1146
Hoist Control Return Tubing	7-320	7-1149
Hydraulic Pump Case Drains	7-328	7-1202
Power Steering Pressure Tubing	7-323	7-1174
Power Steering Return Tubing	7-324	7-1181
PTU Pressure Tubing	7-317	7-1135
PTU Return Tubing	7-318	7-1141
Utility Hydraulic System Serious Contamination	7-16.1	7-106
Wheel Brake Pressure Tubing	7-322	7-1164
Wheel Brake Return Tubing	7-324	7-1181
Flyaway Equipment	1-109	1-391
Foldout Step		
Install	2-175	2-576
Remove	2-174	2-575
Forces Check, Artificial Feel	11-34	11-121

	Task	Page
Formation Lights		
Aft		
Install	9-85	9-278
Remove	9-83	9-275
Forward		
Install	9-84	9-276
Remove	9-82	9-274
Formation Lights, NVG		
Install	9-85.2	9-28
Remove	9-85.1	9-280
Former, Engine Cover		
Adjust	4-44	4-237
Install	4-46	4-240
Remove	4-45	4-238
Formers, Repair	2-18	2-75
Minor Damage	2-19	2-141
Reparable Damage (AVIM)	2-20	2-143
Forms Maintenance	1-2	1-1
Forward Crown Fairing, Pylon - See Pylon Forward Crown Fairing		
Forward Cyclic Trim Indicator - See Cyclic Trim Indicator		
Forward Engine Mounts - See Mounts, Forward Engine		
Forward Fairing, Forward Transmission - See Forward Transmission Forward Fairing		
Forward Auxiliary Fuel Tank		
Install	10-26	10-118
Remove	10-23	10-101
Test After Installtion	10-27	10-124
Forward Auxiliary Fuel Tank Components		
Boost Pump		
Install	10-70	10-344
Remove	10-89	10-342
Cell		
Install	10-25	10-113
Remove	10-24	10-106
Fuel Lines and Wiring		
Install	10-68	10-237
Remove	10-67	10-331
Install	10-26	10-118
Remove	10-23	10-101

	Task	Page
Shutoff Valve		
Install	10-72	10-350
Remove	10-71	10-347
Vent Assembly		
Install	10-66	10-326
Remove	10-65	10-321
Vent Valve		
Install	10-74	10-360
Remove	10-73	10-358
Forward Landing Gear		
Assemble	3-5	3-16
Convert	3-3	3-12
Description	3-1	3-2
Disassemble	3-4	3-14
Inspect	3-16	3-54
Install	3-6	3-21
Lubrication	1-88	1-318
Lubrication Fitting Installation	3-24	3-64
Lubrication Fitting Removal	3-23	3-63
Remove	3-2	3-8
Servicing, Air	1-71	1-268
Servicing, Hydraulic Fluid	1-69	1-261
Forward Landing Gear Access Panel - See Access Panel, Forward Landing Gear		
Forward LCT Actuator Rigged - See Rigging of Forward and Aft LCT Actuator		
Forward LCT Connecting Link - See Connecting Link LCT Forward		
Forward Left or Right Connecting Links		
Clean - See Clean Flight Control System		
Check - Looseness	11-6.2	11-22
Inspect - Bearings (Installed)	11-9	11-42
Inspect - Bearings (Removed)	11-8	11-40
Inspect - General (Without 38)	11-7	11-36
Install	11-195	11-793
Remove	11-194	11-791
Repair	11-14	11-53
Forward Left Upper Bellcrank		
Clean - See Clean Flight Control System		
Inspect - Corrosion - See Corrosion Bellcrank, Inspect		
Inspect - General	11-10	11-45

Task Page

Install	11-199	11-800
Remove	11-198	11-799
Repair - Finish - See Bellcrank and Arm Finish Repair		
Repair - General - See Bellcrank and Control Arms Repair		
Forward Right Upper Bellcrank		
Clean - See Clean Flight Control System		
Inspect - Corrosion - See Corrosion Bellcrank, Inspect		
Inspect - General	11-10	11-45
Install	11-201	11-805
Remove	11-200	11-806
Repair - Finish - See Bellcrank and Arm Finish Repair		
Repair - General - See Bellcrank and Control Arms Repair		
Forward Swashplate - See Swashplates		

	Task	Page
Forward Swashplate and Servocylinder Rigging - See Rig Forward or Aft Swashplate and Servocylinders		
Forward Transmission - See Transmission, Forward		
Forward Transmission Aft Fairing		
Install	2-68	2-289
Prepare for Installation	2-67.1	2-287
Remove	2-63	2-271
Forward Transmission Fairing, Repair		
Damage Requiring Replacement (AVIM)	2-64	2-274
Minor Damage	2-66	2-284
Minor Damage	2-65	2-283
Forward Transmission Forward Fairing		
Install	2-67	2-285
Prepare for Installation	2-67.1	2-287
Remove	2-62	2-269
Forward Upper Bellcranks Rigging - See Rig Forward Upper Bellcrank		
Fuel Boost Pump, APU		
Install	10-98	10-458
Remove	10-97	10-455
Fuel Cell - See Cell, Fuel		
Fuel Contamination	10-33	10-160
FUEL CONTR Overhead Panel		
Install (With 17)	9.98.2	9-329
Install (Without 17) and (Without 74)	9.100	9-388
Remove (With 17)	9-98.1	9-314
Remove (Without 17) and (Without 74)	9-99	9-353
Fuel Control Bleeding, Engine (Without 74)	10-122	10-561
Fuel Control, Engine (Without 74)		
Install	4-16	4-130
Remove	4-15	4-127
Rig - See Linkage, Gas Producer Control		
Fuel Control, Heater		
Install	13-63	13-175
Remove	13-62	13-173
Fuel Control, Overhead Panel		
Install	9-100	9-388
Remove	9-99	9-353
Fuel Drain Valve - See Drain Valve, Fuel		
Fuel Feed System	10-120	10-521
Fuel Filter, Engine Inline	4-19	4-139

	Task	Page
■ Replace	4-19	4-139
Fuel Flow Divider, Engine		
■ Replace	4-20	4-140
Fuel Flow Indicator		
Install	8-87	8-278
Remove	8-86	8-276
Fuel Flow Power Supply		
Install	8-80.4	8-220
Remove	8-80.3	8-219
Fuel Flow Transmitter		
Install	8-80.2	8-217
Remove	8-80.1	8-215
Fuel Level Control Valve and Mounting Bracket, Auxiliary Fuel Tanks		
■ Install	10-60.2	10-308
Remove	10-60.1	10-305
Fuel Level Control and Mounting Bracket, Main Fuel Tanks		
Install	10-60	10-301
Remove	10-59	10-298
Fuel Level Sensor, Low		
Install	10-72.2	10-355
Remove	10-72.1	10-353
Fuel Pod Panels - See Panels, Fuel Pod		
Fuel Pump Relay		
Install	10-116	10-493
Remove	10-115	10-491
Fuel Quantity Indicating Control Unit		
Install	8-80	8-214
Remove	8-79	8-213
Fuel Quantity Indicating Tank Unit		
Install	8-82	8-261
Remove	8-81	8-259
Fuel Quantity Indicator		
Adjust	8-80.5	8-221
Install	8-87	8-278
Remove	8-86	8-276
Test	8-80.5	8-221
Fuel Quantity Inverter		
Install	9-164.2	9-652
Remove	9-164.1	9-651

	Task	Page
Fuel Quantity Switch Box		
Assemble	8-80.8	8-256
Disassemble	8-80.7	8-255
Install	8-80.9	8-258
Remove	8-80.6	8-254
Fuel Quantity System Coaxial Connector Contacts		
Replace	8-82.1	8-263
Fuel System		
Bleeding	10-121	10-550
Description	10-1	10-2
Flushing (Airframe)	10-36	10-178
Flushing (Engine)	10-37	10-193
Theory of Operation	10-1	10-2
Fuel System Drain Valve		
Install	10-94	10-449
Remove	10-93	10-444
Fuel System Dual Check Valve Fitting		
Install	10-96	10-453
Remove	10-95	10-451
Fuel System Wiring - See Fuel Lines and Wiring		
Fuel Tank, Aft Auxiliary - See Aft Auxiliary Fuel Tank		
Fuel Tank, Forward Auxiliary - See Forward Auxiliary Fuel Tank		
Fuel Tank, Main - See Main Fuel Tank		
Fuel Tank Breakway Fittings		
Install	10-48.2	10-241
Install (Captive)	10-48.4	10-244
Remove	10-48.1	10-239
Remove (Captive)	10-48.3	10-243
Fuel Tank Drain Valve		
Install	10-40	10-205
Remove	10-39	10-204
Fuel Tank Isolation Panel		
Install	2-192	2-694
Remove	2-191	2-692
Fuel Tank Inspection, Hard Landings	10-5	10-34
Fuel Tank Vent Fairing		

	Task	Page
Install	10-64	10-319
Remove	10-63	10-317
Fuel Tank Vent Replacement	2-210.2	2-759
Fuel Vent System		
Flow Test	10-118	10-504
Pressure Test	10-117	10-499
Full Authority Digital Engine Control (FADEC) System (With 74)		
Depreserve the Powerplant	4-158	4-514
Digital Electronic Control Unit (DECU)		
Historical Files Upload and Download	4-149	4-492
Replace No. 1	4-147	4-486
Replace No. 2	4-148	4-489
FADEC Control Panel		
Install	4-151	4-494
Remove	4-150	4-493
FADEC Relay Panel		
Install	4-155	4-511
Remove	4-154	4-510
Leak Test FADEC P3 Signal Line	4-159	4-517
Power Assurance Panel and Test Switch		
Install	4-157	4-513
Remove	4-156	4-512
Thrust Control Position Transducer (CPT) Assembly		
Install and Rig	4-153	4-498
Remove	4-152	4-495
Fuse Replacement, Heater Ignition Unit	13-64	13-177
Fuselage Drain Plug		
Install	2-215	2-775
Remove	2-214	2-773
Fuselage Equipment Support Structure	2-4	2-22
Repair	2-166	2-537
Fuselage and Pylon Damage Inspection	2-4	2-22
Fuselage Sealing	2-324	2-1129
G		
Gas Producer Actuator (Without 74)		
Install	4-109	4-394
Remove	4-108	4-392
Gas Producer Control Box (Without 74)		
Install	4-107	4-391

	Task	Page
Remove	4-106	4-390
Gas Producer Control Linkage - See Linkage, Gas Producer		
Gas Producer Control System (Without 74)		
Adjust	4-102	4-372
Gas Producer Tachometer		
Install	8-87	8-278
Remove	8-86	8-276
Test (Without 74)	8-8	8-28
Gate, Cargo Ramp		
Install	2-257.2	2-902
Remove	2-257.1	2-900
Gearbox, Rescue Hatch Lower Door - See Rescue Hatch Lower Door Gearbox		
Generator, APU - See APU Components		
Generator Contactor		
Install	9-50	9-148
Remove	9-49	9-146
Generator Control Panel		
Install	9-36	9-116
Remove	9-35	9-114
Generator, Main AC - See Main AC Generators		
Generator, Tachometer, No. 1 Gas Producer (Without 74)		
Install	8-12	8-37
Remove	8-9	8-30
Test	8-11	8-34
Generator, Tachometer, No. 2 Gas Producer (Without 74)		
Install	8-13	8-39
Remove	8-10	8-32
Test	8-11	8-34
Glass Cloth Parts, Impregnated, Repair	2-357	2-1243
Glass Windshield, Center - See Windshield, Glass, Center		
Glass Windshield, Pilot or Copilot - See Windshield, Glass, Pilot or Copilot		
Glossary		
GPS Antenna Mount Provision 71		
Install	2-170.2	2-563
GPS Antenna Mount Template Fabrication: 71	2-170.3	2-568
Gravity Refueling	1-51.1	1-201
Grip, Pitch and Roll Control Stick - See Pitch and Roll Control Stick Grip		
Grip, Thrust Control - See Thrust Control		
Grip, Winch Control - See Winch Control Grip		

Ground Device Module

Install	9-168	9-674
Remove	9-167	9-672

Ground (External) Power

Electrical	1-37	1-132
Hydraulic	1-38	1-134

Grounding	1-29	1-94
-----------------	------	------

Grounding Receptacle Replacement, Ferry Fuel System	2-210.1	2-757
---	---------	-------

H

Handgrip

Install	2-177	2-580
Remove	2-176	2-578

Handpump, Handle

Remove	7-140.1	7-630
Disassemble	7-140.2	7-631
Assemble	7-140.3	7-633
Install	7-140.4	7-635

Handpump, Hydraulic

Install	7-140	7-628
Remove	7-136	7-626

Hard Landings, Inspect Fuel Tanks	10-5	10-34
---	------	-------

Harness, Engine Electrical (Without 74)	4-11.2	4-79
---	--------	------

Harness, Hoist Operator's

Inspect	14-18	14-54
---------------	-------	-------

Harness, Shoulder - See Shoulder Harness

Hatch, Escape, Forward Cabin - See Escape Hatch, Forward Cabin

Hatch, Rescue, Lower Door - See Rescue Hatch Lower Door

Head, Rotary-Wing - See Rotary-Wing Head

Health Indicator Test (HIT) (Without 74)	4-2	4-12
--	-----	------

Heater

Assemble (AVIM) (With 16)	13-6.1	13-36
Assemble (AVIM) (Without 16)	13-6	13-28
Clean Parts (AVIM)	13-4	13-21
Disassemble (AVIM)	13-3	13-16
Drain Cleaning	13-9	13-52
Igniter (Spark Plug)		
Install	13-11	13-57
Remove	13-10	13-56
Inspect Parts (AVIM)	13-5	13-25

	Task	Page
Install	13-8	13-46
Remove	13-2	13-10
Test for Air Leaks (AVIM)	13-7	13-45
Heater Control Relay Box		
Install	13-57	13-167
Remove	13-54	13-160
Heater Fan - See Fan, Heater		
Heater Fan Relay		
Install	9-54	9-159
Remove	9-53	9-157
Heater Fuel Solenoid Valve		
Install	13-49	13-152
Remove	13-48	13-150
Heater Ignition Lead		
Install	13-68	13-183
Remove	13-67	13-182
Heater Ignition Unit		
Remove	13-65	13-178
Install	13-66	13-180
HEATING Overhead Panel		
Install (With 17)	9.98.2	9-329
Install (Without 17)	9.100	9-388
Remove (With 17)	9-98.1	9-314
Remove (Without 17)	9-99	9-353
Hinge Repair		
Hinge, Lower Cabin Door - See Cabin Door, Lower, Hinge		
Hinged Fairing, Pylon - See Work Platform, Pylon		
Hinged Fairing, Pylon Leading Edge (Clamshell Doors)		
Install	2-281	2-958
Latch		
Assemble (AVIM)	2-282.2	2-962
Disassemble (AVIM)	2-282.1	2-961
Install	2-283	2-963
Remove	2-282	2-960
Remove Hinged Fairing	2-279	2-954
Repair	2-280	2-956
Hoist - See Winch		
HOIST/CARGO HOOK Panel		
Assemble (AVIM) (With 17)	9-99.5.1	9-381

	Task	Page
Assemble (AVIM) (Without 17)	9-99.5	9-377
Disassemble (AVIM) (With 17)	9-99.4.1	9-374
Disassemble (AVIM) (Without 17)	9-99.4	9-371
Install	9-100	9-388
Remove	9-99	9-353
Test (AVIM)	9-99.6	9-385
Hoist Control Shutoff Valve		
Install	7-252	7-929
Remove	7-251	7-927
Hoist Control Valve		
Install	7-250	7-925
Remove	7-249	7-923
Hoist Operator's Harness		
Inspect	14-18	14-54
Hoist Operator's Panel		
Install	9-157	9-632
Remove	9-155	9-628
Repair	9-156	9-630
Hoist Pressure Reducing Valve		
Assemble (AVIM)	7-257	7-940
Disassemble and Inspect (AVIM)	7-256	7-937
Install	7-259	7-950
Remove	7-255	7-935
Test (AVIM)	7-258	7-943
Hoist Pressure Relief Valve		
Install	7-254	7-933
Remove	7-253	7-931
Hoisting	1-35	1-122
Hoisting Unit		
Azimuth Control		
Assemble	1-43	1-162
Disassemble	1-42	1-159
Boom		
Assemble	1-47	1-174
Disassemble	1-46	1-168
Install	1-40	1-138
Jib Boom		
Assemble	1-45	1-166

	Task	Page
Disassemble	1-44	1-165
Mast		
Assemble	1-49	1-183
Disassemble	1-48	1-180
Remove	1-41	1-149
Hook and Cable Assembly, Winch		
Inspect	14-12	14-43
Install	14-14	14-46
Remove	14-13	14-45
Hook Release Valve		
Assemble (AVIM)	7-263	7-959
Hook System, External	16-1	16-2
Hook System Release Valve, External	16-2	16-10
Disassemble (AVIM)	7-261	7-954
Inspect (AVIM)	7-262	7-956
Install	7-265	7-965
Remove	7-260	7-952
Test (AVIM)	7-264	7-961
Honeycomb Structures Repair	2-358	2-1244
Horizontal Hinge Pin - See Pin, Horizontal Hinge		
Horizontal Hinge Pin Bearings - See Bearings, Horizontal Hinge Pin		
Horizontal Hinge Pin Bearing Cap - See Cap, Horizontal Hinge Pin Bearing		
Horizontal Hinge Pin Oil Seals - See Seals, Oil, Horizontal Hinge Pin		
Horizontal Situation Indicator (HSI)		
Install	8-91	8-288
Remove	8-90	8-286
Repair	8-48	8-145
Hot Weather Maintenance	1-84	1-310
Housing, Pitch Varying		
Install	5-23	5-114
Remove	5-22	5-111
How To Use This Manual		v
HSI - See Horizontal Situation Indicator		
HSI Mode Select Panel - See Mode Select Panel, HSI		
Hub Oil Tank Sight Indicator - See Sight Indicator, Hub Oil Tank		
Hydraulic Fluid Sampling	7-8.1	7-56

Hydraulic Maintenance Panel - See Panel, Hydraulic Maintenance

HYDRAULIC Overhead Panel

Install (With 17)	9-98.2	9-329
Install (Without 17)	9-100	9-388
Remove (With 17)	9-98.1	9-314
Remove (Without 17)	9-99	9-353

Hydraulic Power External Application	1-38	1-134
--	------	-------

Hydraulic Pressure Indicator

Install	8-101	8-319
Remove	8-100	8-309
Test	8-83	8-271

Hydraulic Pump Drive Shaft Seal - See Flight Control Hydraulic Pumps

Hydraulic Reservoir Level Indicator

Install	8-101	8-319
Remove	8-100	8-309
Test	8-84	8-272

Hydraulic System

Bulkhead Fittings	7-4.1	7-20
Components Inspection	7-1.1	7-14
Contamination Inspection	7-8	7-54

Hydraulic System, Flight Control - See Flight Control Hydraulic System

Hydraulic System Leakage, General	7-7	7-52
---	-----	------

Hydraulic System Plumbing

Fluid Sampling	7-8.1	7-56
Inspect, General	7-2	7-15
Install, General	7-4	7-18
Remove, General	7-3	7-16
Repair, Permaswage	7-5	7-27
Tube Bending (AVIM)	7-4.2	7-22

Hydraulic System, Utility	7-135	7-608
---------------------------------	-------	-------

	Task	Page
Depressurize	7-135.1	7-622
Flush Serious Contamination	7-10	7-64
Hydraulic Temperature Indicator		
Install	8-101	8-319
Remove	8-100	8-309
Test	8-85	8-275
I		
Idler Arms, Flight Control System		
Inspect	11-10	11-45
Idler Bellcrank, Aft Fuselage		
Clean - See Clean Flight Control System		
Inspect - Corrosion - See Corrosion Bellcrank, Inspect		
Inspect - General	11-10	11-45
Install	11-247	11-959
Remove	11-246	11-957
Repair - Finish - See Bellcrank and Arm Finish Repair		
Repair - General - See Bellcrank and Control Arms Repair		
Rig	11-57	11-259
Idler Control Tunnel - See Tunnel Control Idler		
Igniter (Spark Plug), Heater		
Install	13-11	13-57
Remove	13-10	13-56
Ignition Switch		
Install	4-101	4-368
Remove	4-100	4-366
Ignition Unit, Heater		
Fuse		
Replace	13-64	13-177
Install	13-66	13-180
Remove	13-65	13-178
Lead, Shielded		
Install	13-68	13-183
Remove	13-67	13-182
ILCA - See Integrated Lower Control Actuator		
ILCA Intermediate Connecting Links		
Check - Bearings	11-15	11-60
Check - Looseness	11-6	11-18
Inspect - Bearings (Installed)	11-9	11-42
Inspect - Bearings (Removed)	11-8	11-40

	Task	Page
Inspect - General	11-7	11-36
Install	11-179	11-714
Remove	11-178	11-707
Repair - See Connecting Link, Flight Control System		
Inclinometer		
Install	16-95	16-343
Remove	16-94	16-342
Indicator, Airspeed		
Install	8-91	8-288
Remove	8-90	8-286
Indicator, Attitude		
Install	8-91	8-288
Remove	8-90	8-286
Repair	8-55	8-152
Test	8-56	8-153
Indicator, Cruise Guide		
Install	8-91	8-288
Remove	8-90	8-286
Indicator, Cyclic Trim		
Install	8-87	8-278
Remove	8-86	8-276
Test	8-43	8-129
Indicator, Engine Dual Torque		
Adjust (Without 74)	8-18.1	8-57
Install	8-89	8-283
Remove	8-88	8-281
Test (AVIM) (Without 74)	8-19	8-61
Indicator, Engine Emergency Power (Without 74)		
Install	8-4	8-22
Lamp Replacement	8-5	8-24
Remove	8-3	8-20
Indicator, Engine Oil Pressure		
Install	8-87	8-278
Remove	8-86	8-276
Test	8-14	8-42
Indicator, Engine Oil Temperature		
Install	8-87	8-278
Remove	8-86	8-276
Test	8-17	8-54

	Task	Page
Indicator, Filter, Utility Pressure Control Module		
Install	7-159	7-686
Remove	7-158	7-684
Indicator, Filter, Utility Return Control Module		
Install	7-199	7-781
Remove	7-198	7-779
Indicator, Free Air Temperature		
Install	8-96	8-303
Remove	8-94	8-301
Test	8-95	8-302
Indicator, Fuel Flow		
Install	8-87	8-278
Remove	8-86	8-276
Indicator, Fuel Quantity		
Adjust	8-80.5	8-221
Install	8-87	8-278
Remove	8-86	8-276
Test	8-80.5	8-221
Indicator, Horizontal Situation (HSI)		
Install	8-91	8-288
Remove	8-90	8-286
Repair	8-48	8-145
Indicator, Hydraulic Pressure		
Install	8-101	8-319
Remove	8-100	8-309
Test	8-83	8-271
Indicator, Hydraulic Reservoir Level		
Install	8-101	8-319
Remove	8-100	8-309
Test	8-84	8-272
Indicator, Hydraulic Temperature		
Install	8-101	8-319
Remove	8-100	8-309
Test	8-85	8-275
Indicator, Power Turbine Inlet Temperature (PTIT)		
Install	8-87	8-278
Remove	8-86	8-276
Test	8-2	8-16

	Task	Page
Indicator, Pump Fail, Utility Return Control Module		
Install	7-205	7-793
Remove	7-204	7-791
Indicator, Stick Pitch Position		
Install	11-84	11-442
Remove	11-83	11-438
Rig	11-45	11-192
Indicator, Tachometer, Gas Producer		
Install	8-87	8-278
Remove	8-86	8-276
Test (Without 74)	8-8	8-28
Indicator, Tachometer, Rotor		
Install	8-89	8-283
Remove	8-88	8-281
Indicator, Transmission Oil Pressure		
Install	8-87	8-278
Remove	8-86	8-276
Test (AVIM)	8-58	8-166
Indicator, Transmission Oil Temperature		
Install	8-87	8-278
Remove	8-86	8-276
Test (AVIM)	8-73	8-196
Indicator, Turn and Slip		
Install (With 17)	8-45.1	8-137
Install (Without 17)	8-45	8-134
Remove (With 17)	8-44	8-130
Remove (Without 17)	8-44	8-130
Inertia Reel, Pilot or Copilot Shoulder Harness		
Install	2-122	2-428
Remove	2-117	2-417
Control		
Install	2-124	2-431
Remove	2-123	2-430
Lever Throw		
Adjust	2-125	2-433
Strap		
Install	2-121	2-426
Remove	2-120	2-424
Test	2-116	2-415

	Task	Page
Inertia Switch, Emergency Light		
Install	17-12	17-28
Remove	17-11	17-27
Initial Runup of Powerplant	4-4	4-33
Inlet Duct, Air, Heater		
Install	13-19	13-74
Remove	13-18	13-72
Insert, Screw-Thread, Replacement	1-16	1-27
Inserts, Threaded, Forward and Aft Cargo Hook		
Install (AVIM)	16-26	16-134
Remove (AVIM)	16-25	16-132
Inspect Skin, Oilcan - See Skin Inspection, Oilcan		
Inspection	1-92	1-338
Inspection, Component		
Bellcranks and Idler Arms, Flight Control System	11-10	11-45
Bearings, Rod End, Connecting Link (Installed)	11-9	11-42
Bearings, Rod End Connecting Link (Removed)	11-8	11-40
Cockpit Windows	2-54	2-252
Fuel Tanks	10-4	10-31
Rotary-Wing Blade Shock Absorber	5-87.1	5-525
Inspection, Storage		
Flyable Storage		
After	1-100	1-369
Before	1-96	1-362
During	1-98	1-366
Intermediate Storage		
After	1-108	1-390
Before	1-105	1-381
Lightning Strike	2-5	2-23
Short Term Storage		
After	1-104	1-380
Before	1-101	1-370
Install Lower Controls Actuator Structural Manifold Check Valve Assembly	7-103.2	7-490.2
Installation of AN Bolts for AN Rivets - See Bolts, AN, Installation for AN Rivets		
Instrument Panel - See Panel, Instrument		
Instrument Panel Lights - See Light, Instrument		
Instrument Transformer		

	Task	Page
Install	9-46	9-138
Remove	9-45	9-136
Instruments		
Clamp Mounted, Center Panel		
Install	8-87	8-278
Remove	8-86	8-276
Clamp Mounted, Pilot/Copilot Panel		
Install	8-89	8-283
Remove	8-88	8-281
Flange Mounted, Pilot/Copilot Panel		
Install	8-91	8-288
Remove	8-90	8-286
Instruments, Engine	8-1	8-2
Instruments, Flight	8-23	8-74
Instruments, Hydraulic Maintenance Panel		
Install	8-98	8-306
Remove	8-97	8-304
Instruments, Miscellaneous	8-57	8-156
Integrated Lower Control Actuator (ILCA)		
Inspect	7-83.1	7-333
Install (AVUM)	7-102	7-485
Remove (AVUM)	7-84	7-337
Test (AVIM)	7-98	7-402
Integrated Lower Actuator (ILCA) (Components)		
Check Valve		
Install (AVIM)	7-94	7-370
Remove (AVIM)	7-93	7-369
Cross Feedback Transducer		
Adjust (AVIM)	7-100	7-477
Adjust on Helicopter	7-99	7-473
Install (AVIM)	7-88	7-355
Remove (AVIM)	7-87	7-354
Extensible Link		
Actuator Cylinder Functional Test	7-97	7-377
Adjust Self Feedback Transducer (AVIM)	7-101	7-481
Install	7-86	7-350
Install Piston Seals	7-85.2	7-345
Install Pressure Port Filter	7-85.4	7-349
Install Self Feedback Transducer (AVIM)	7-88.2	7-360

	Task	Page
Install Servo Valve (AVIM)	7-96	7-375
Remove	7-85	7-340
Remove Piston Seals	7-85.1	7-342
Remove Pressure Port Filter	7-85.3	7-348
Remove Self Feedback Transducer (AVIM)	7-88.1	7-357
Remove Servo Valve (AVIM)	7 95	7-372
Jam Sensor		
Install (AVIM)	7-90	7-364
Remove (AVIM)	7-89	7-362
Test	7-104.1	7-493
Relief Valve		
Install (AVIM)	7-92	7-367
Remove (AVIM)	7-91	7-365
Seals, Piston, Extensible Link		
Install	7-85.2	7-345
Remove	7-85.1	7-342
Transducer, Self-Feedback, Extensible Link		
Install	7-88.2	7-360
Remove	7-88.1	7-357
Interior/Exterior Metal Structures, Final Finish	2-352	2-1210
Interior Structures Detail or Repair Parts, Finish - See Finish Interior Structures Detail or Repair Parts		
INTR LTG Overhead Panel		
Install (With 17)	9-98.2	9-329
Install (Without 17)	9-100	9-388
Remove (With 17)	9-98.1	9-314
Remove (Without 17)	9-99	9-353
Inventory, Aircraft	1-109	1-391
Inverter, Fuel Quantity		
Install	9-164.2	9-652
Remove	9-164.1	9-651
Isolation Panel, Fuel Tank		
Install	2-192	2-694
Remove	2-191	2-692
J		
Jacking		
Aft End	1-24	1-82
Entire Helicopter	1-21	1-70
Forward Fuselage Jack Pad	1-22	1-76

	Task	Page
Forward Landing Gear	1-23	1-81
Jam Indicator Test, Servocylinder	7-123.1	7-543
Jam Sensor, Integrated Lower Control Actuator (ILCA) - See Integrated Lower Control Actuator Jam Sensor		
Jet Pump, Fuel		
Install	10-48	10-236
Remove	10-47	10-233
Jet Pump Motive Flow Check Valve		
Install	10-50	10-247
Remove	10-49	10-245
Jettisonable Door Connecting Links		
Clean	2-87	2-336
Install	2-92	2-352
Remove	2-91	2-351
Jettisonable Door Lower Fixed Window		
Install	2-104	2-379
Remove	2-103	2-378
Jettisonable Door, Pilot or Copilot		
Install and Adjust	2-90	2-344
Install Without Adjustment	2-89	2-340
Remove	2-86	2-335
Repair	2-88	2-338
Test	2-85	2-329
Jettisonable Door Sliding Window		
Adjust	2-98	2-364
Bushings		
Replace	2-95	2-357
Install	2-97	2-362
Locking Mechanism		
Install	2-100	2-371
Remove	2-99	2-368
Plastic Panel		
Install	2-96	2-358
Remove	2-94	2-355
Remove	2-93	2-353
Test	2-105	2-380
Jettisonable Door Upper Fixed Window		
Install	2-102	2-376
Remove	2-101	2-374

	Task	Page
Junction Box - See Countermeasures Dispenser System Junction Box		
Jump Signal Dimming Resistor - See Troop Jump Signal Dimming Resistor		
Jumper Wire, Lighting Protection		
Replace	5-77.1	5-444
K		
Keeper, Forward and Aft Cargo Hook		
Install	16-22	16-113
Remove	16-21	16-112
L		
Lag Damper - See Shock Absorber, Rotary-Wing Blade		
Lamp, Fire Pull Handle		
Replace	12-14	12-43
Landing Gear Description	3-1	3-2
Landing Gear, Aft - See Aft Landing Gear		
Landing Gear Bypass Status Panel - See Countermeasures Dispenser System Landing Gear Bypass Status Panel		
Landing Gear, Forward - See Forward Landing Gear		
Landing Light		
Adjust (AVIM)	9-78	9-263
Assemble (AVIM)	9-77	9-259
Description	9-60	9-168
Disassemble (AVIM)	9-70	9-236
Install	9-79	9-267
Remove	9-69	9-233
Test (AVIM)	9-78	9-263
Theory of Operation	9-60	9-168
Landing Light Components		
Extend Gearbox		
Assemble (AVIM)	9-76	9-255
Disassemble (AVIM)	9-71	9-240
Lamp		
Install	9-81	9-272
Remove	9-80	9-270
Motor		
Assemble (AVIM)	9-74	9-248
Disassemble (AVIM)	9-73	9-246
Rotating Mechanism		
Assemble (AVIM)	9-75	9-251
Disassemble (AVIM)	9-72	9-243
Latch, Pylon Leading Edge - See Hinged Fairing, Pylon Leading Edge (Clamshell Doors)		
LCT Actuator, Aft - See Actuator, LCT		

	Task	Page
LCT Actuator, Forward - See Actuator LCT		
LCT Yoke, Forward - See Yoke, Forward LCT		
Lead/Lag Tool		
Install	11-30	11-99
Remove	11-31	11-101
Lead, Shielded, Heater Ignition Unit		
Install	13-68	13-183
Remove	13-67	13-182
Leak Check, Windshield or Window	2-61	2-267
Leak Test, FADEC P3 Signal Line (With 74)	4-159	4-517
Leak Test, Fuel Vent System	10-118	10-504
Leak Test, Light - See Light Leak Test		
Leak Test, Pressure Refueling System	10-119	10-509
Leakage, Hydraulic System (General)	7-7	7-52
Leakage, Rotary-Wing Head Oil Tanks	5-6.1	5-36
Left Upper Pylon Connecting Link - See Connecting Link Left Upper Pylon		
Lever, Manual Release, Forward and Aft Cargo Hook		
Install	16-41	16-209
Remove	16-36	16-195
Lever, Throw, Inertia Reel, Pilot or Copilot Shoulder Harness - See Inertia Reel, Pilot or Copilot Shoulder Harness, Lever Throw		
Light Leak Test (With 17 and 74)	9-124.1	9-476
Light, Anticollision - See Anticollision Light		
Light, Cabin/Ramp Dome - See Cabin/Ramp Dome Light		
Light, Cockpit Dome - See Cockpit Dome Light		
Light, Emergency Power (Without 74)		
Install	8-4	8-22
Lamp		
Replace	8-5	8-24
Remove	8-3	8-20
Light, Emergency Exit		
Assemble	17-6	17-15
Battery Charging	17-7	17-19
Disassemble	17-5	17-12
Install	17-8	17-21
Panel and Pan		
Install	17-10	17-25
Remove	17-9	17-23
Remove	17-4	17-10

	Task	Page
Light, Instrument		
Pilot and Copilot Panel		
Install	8-110	8-358
Remove	8-109	8-354
Center Panel		
Install	8-112	8-364
Remove	8-111	8-362
Light, Landing - See Landing Light		
Light, Oil Level Check - See Oil Level Check Light		
Light, Side Position - See Side Position Light		
Light, Tail Position - See Tail Position Light		
Light, Utility - See Utility Light		
Lighting Relays, Cabin and Ramp		
Install	9-117	9-445
Remove	9-99	9-353
Lighting System	9-60	9-168
Lighting Transformer, 26V		
Install	9-62	9-220
Remove	9-61	9-218
Lightning Protection Strip Unbonding Repair	5-81.3	5-474
Lightning Strike Inspection (Aircraft)	2-5	2-23
Lightning Strike Inspection, Rotary-Wing Blade	5-63.2	5-280
Link, Aft LCT		
Check - Looseness	11-6.2	11-22
Inspect - Bearings (Installed)	11-9	11-42
Inspect - Bearings (Removed)	11-8	11-40
Inspect - General	11-7	11-36
Install	11-225	11-876
Remove	11-222	11-868
Repair	11-14	11-53
Link LCT Lower Fitting Bearing		
Clean, See Clean Flight Control System		
Check - Looseness	11-6.2	11-22
Inspect - Bearing (Installed)	11-9	11-42
Inspect - Bearing (Removed)	11-8	11-40
Inspect - General	11-7	11-36
Install Bearing (AVIM)	11-224	11-873
Remove Bearing (AVIM)	11-223	11-872

Repair	11-14	11-53
Link Connecting - See Connecting Link Flight Control System		
Link Connecting Rod End Bearing Adjust or Fixed (Installed), Inspect	11-9	11-42
Link, Drag, Lower, Aft Landing Gear - See Lower Drag Link, Aft Landing		
Link, Drag, Upper, Aft Landing Gear - See Upper Drag Link, Aft Landing Gear		
Link Dummy, Dash Actuator - See Dash Actuator Dummy Link		
Link, Extensible - See Extensible Link		
Link Rod End Bearing LCT - See Bearing LCT Link Rod End		
Linkage Rigging, Aft Cabin and Pylon - See Rig Aft Cabin and Pylon Linkage		
Linkage Bearing Check, Flight Control System	11-15	11-60
Linkage, Gas Producer (N1) Control (Without 74)		
Inspect Rod	4-115	4-407
Install and Rig	4-113	4-399
Install Rod	4-117	4-409
Repair Rod	4-116	4-408
Remove	4-112	4-397
Remove Rod	4-114	4-405
Linkage, Power Turbine (N2) Control (Without 74)		
Inspect Rod	4-133	4-443
Install and Rig	4-140	4-454
Install Rod	4-135	4-445
Repair Rod	4-134	4-444
Remove	4-136	4-447
Remove Rod	4-132	4-441
Links, APU Aft Mount Connecting		
Inspect	15-5	15-26
Install	15-7	15-32
Remove	15-6	15-28
Links Connecting Flight Control System, Inspect	11-7	11-36
Links, Connecting, Jettisonable Door - See Jettisonable Door Connecting Links		
Links Connecting Pitch Intermediate - See Connecting Links Pitch Intermediate		
Links Connecting Rod End Bearings Adjust or Fixed (Removed), Inspect	11-8	11-40
Links Connecting Roll Intermediate - See Connecting Links Roll Intermediate		
Links Connecting Transfer - See Cockpit Control Transfer Connecting Links		
Links Connecting Thrust Intermediate - See Connecting Links Thrust Intermediate		
Links, Rescue Hatch Lower Door - See Rescue Hatch Lower Door Links		
Lights, Formation - See Formation Lights		
Limit Switches, Winch		

	Task	Page
Litter Provisions	16-60	16-252
Litters		
Bracket		
Install	16-64	16-259
Remove	16-63	16-258
Stanchion		
Install	16-62	16-256
Remove	16-61	16-254
Strap		
Install	16-66	16-261
Remove	16-65	16-260
Lock Mechanism, Static, Aft Landing Gear - See Static Lock Mechanism, Aft Landing Gear		
Lock, Swivel, Aft Landing Gear		
Locking Mechanism, Jettisonable Door Sliding Window - See Jettisonable Door Sliding Window Locking Mechanism		
Lockpins, Pitch Link		
Install	5-96.1	5-579
Remove	5-96.2	5-581
Locks, Security	1-28	1-91
Longeron Repair, Right Lower (AVIM)	2-32	2-188
Longerons, Repair	2-21	2-144
Minor Damage	2-22	2-145
Reparable Damage (AVIM)	2-23	2-148
Longitudinal Cyclic Trim - See LCT		
Looseness Check, Flight Controls - See Flight Controls Looseness Check		
Low Fuel Level Sensor		
Install	10-72.2	10-355
Remove	10-72.1	10-353
Lower Access Door Engine		
Repair (General Information)	4-60	4-268
Repair (Major Damage)	4-62	4-273
Repair (Minor Damage)	4-61	4-271
Lower Controls Actuator Structural Manifold - See Manifold Lower Controls		
Lower Controls Module		
Install	7-79	7-323
Pressure Reducer		

	Task	Page
Install	7-83	7-331
Remove	7-82	7-329
Remove	7-78	7-321
Solenoid Valve		
Install	7-81	7-327
Remove	7-80	7-325
Lower Drag Link Aft Landing Gear		
Assemble (AVIM)	3-47	3-122
Disassemble (AVIM)	3-44	3-118
Inspect Parts (AVIM)	3-45	3-119
Install	3-48	3-124
Remove	3-43	3-116
Repair Parts (AVIM)	3-46	3-121
LTG Overhead Panel		
Install (With 17)	9-98.2	9-329
Install (Without 17)	9-100	9-388
Remove (With 17)	9-98.1	9-314
Remove (Without 17)	9-99	9-353
Lubrication		
Bearing, Rod End, Flight Control System	11-3	11-9
Drive Shaft Bearings	1-89	1-321
Landing Gear	1-88	1-318
Swashplate	1-90	1-323
Lubrication Chart	1-87	1-316
Lubrication Fitting, Aft Landing Gear		
Install	3-38.2	3-95
Remove	3-38.1	3-93
Lubrication Fitting, Forward Landing Gear		
Install	3-24	3-64
Remove	3-23	3-63
M		
Magnetic Compass		
Install	8-47	8-143
Remove	8-46	8-140
Magnesium Alloy Parts, Finish (Inorganic Surface Treatment) - See Finish Magnesium Alloy Parts (Inorganic Surface Treatment)		
Main AC Generator Oil Outlet Screens		
Inspect	6-158.2	6-549
Install	6-158.3	6-550

	Task	Page
Remove	6-158.1	6-548
Main AC Generators		
Install	9-32	9-102
Remove	9-31	9-100
Main Current Transformer		
Install	9-40	9-125
Remove	9-39	9-123
Main Fuel Tank		
Inspect	10-4	10-31
Install	10-21	10-84
Remove	10-6	10-39
Test After Installation	10-22	10-89
Main Fuel Tank (Components)		
Aft Boost Pump and Check Valve		
Install	10-54	10-263
Remove	10-53	10-259
Cell		
Install	10-20	10-78
Remove	10-7	10-43
Crossover Hose		
Install (Without 82)	10-88.3	10-420
Install (With 82)	10-88.4	10-423
Remove (Without 82)	10-88.1	10-414
Remove (With 82)	10-88.2	10-417
Forward Boost Pump and Check Valve		
Install	10-52	10-254
Remove	10-51	10-249
Fuel Lines and Wiring		
Install	10-42	10-211
Remove	10-41	10-207
Jet Pump		
Install	10-48	10-236
Remove	10-47	10-233
Jet Pump Motive Flow Check Valve		
Install	10-50	10-247
Remove	10-49	10-245
Servicing Check Valve, No. 1 System		
Install (Without 82)	10-90	10-432

	Task	Page
Install (With 82)	10-90.1	10-435
Remove (Without 82)	10-89	10-426
Remove (With 82)	10-89.1	10-429
Servicing Check Valve, No. 2 System		
Install	10-92	10-441
Remove	10-91	10-438
Shutoff Valve, No. 1 System		
Install	10-56	10-281
Remove	10-55	10-269
Shutoff Valve, No. 2 System		
Install	10-58	10-294
Remove	10-57	10-291
Suction Feed Check Valve		
Install	10-62	10-314
Remove	10-61	10-312
Vent Assy		
Install	10-44	10-220
Remove	10-43	10-215
Vent Valve		
Install	10-46	10-231
Remove	10-45	10-226
Maintenance Allocation Chart (MAC)		B-1
Maintenance Crane - See Hoisting Unit		
Maintenance Forms, Records, and Reports	1-2	1-2
Maintenance Panel - See Panel, Hydraulic Maintenance		
Manifold, Hydraulic Structural Lower Controls		
Install	7-104	7-490
Remove	7-103	7-488
Manifolds, Water Wash, Nozzels and (With 74)		
Replace	4-141	4-464
Manual Release, Forward and Aft Cargo Hook		
Bellcrank		
Install (With 35)	16-40.1	16-207
Install (Without 35)	16-40	16-205
Remove (Without 35)	16-37	16-197
Remove (With 35)	16-37.1	16-199
Cable, External		
Adjust	16-35.1	16-191

	Task	Page
Install	16-33	16-180
Remove	16-32	16-178
Cable, Interior		
Adjust	16-35.1	16-191
Install	16-35	16-186
Remove	16-34	16-183
Lever		
Install	16-41	16-209
Remove	16-36	16-195
Mount		
Install	16-39	16-203
Remove	16-38	16-201
Manual Valve, Defueling		
Install	10-110	10-479
Remove	10-109	10-477
Marking Instructions, Interior and Exterior	2-352	2-1210
Master Caution Panel (With 74)		
Assemble (AVIM)	9-129.2	9-519
Disassemble (AVIM)	9-129.1	9-517
Install	9-131.1	9-531
Remove	9-128.1	9-512
Master Caution Panel (Without 74)		
Assemble (AVIM)	9-130	9-522
Disassemble (AVIM)	9-129	9-514
Install	9-131	9-529
Remove	9-128	9-510
Test (AVIM)	9-130.1	9-526
Master Caution Panel Components		
Lamp (Without 74)		
Install	9-127	9-508
Remove	9-126	9-505
Lamp (With 74)		
Install	9-127	9-508
Remove	9-126.1	9-506
Light Plate Assembly (With 17)		
Install	8-114	8-368
Remove	8-113	8-367
NVG Filter (With 17 and Without 74)		
Install	9-125.3	9-504

	Task	Page
Remove	9-125.1	9-498
Repair	9-125.2	9-500
Master Cylinder, Brake - See Brake Master Cylinder		
Materials, Army, Destruction of to Prevent Enemy Use	1-3	1-1
Materials, Expendable	1-18	1-38
Mid Crown Fairing, Pylon - See Pylon Mid Crown Fairing		
Minimum Rotor Rpm, Adjustment (Without 74)	4-129	4-433
Minor Damage, Classification of	2-6	2-24
Minor Damage Removal, Extrusions - See Extrusions, Minor Damage Removal		
Mirror, Rearview, Cockpit		
Install	2-137	2-468
Remove	2-136	2-467
Miscellaneous Electric	9-125	9-490
Miscellaneous Control Panel - See Countermeasures Dispenser System Miscellaneous Control Panel		
Mixing Assembly First Stage - See First Stage Mixing Assembly		
Mixing Assembly Second Stage - See Second Stage Mixing Assembly		
Mixing Linkage Connecting Links		
Clean - See Clean Flight Control System		
Check - Looseness	11-6	11-18
Inspect - Bearings (Installed)	11-9	11-42
Inspect - Bearings (Removed)	11-8	11-40
Inspect - General	11-7	11-36
Install	11-187	11-736
Remove	11-186	11-730
Repair	11-14	11-53
Mode Select Panel, HSI		
Install	8-91	8-288
Remove	8-90	8-286
Repair	8-49	8-146
Test	8-50	8-147
Module Accumulator Power Steering/Swivel Lock - See Power Steering/Swivel Lock Module Accumulator		
Module Assy Power Steer/Swivel - See Power Steer/Swivel Lock Module		
Module, APU Start		
Accumulator 60910		
Assemble (AVIM)	7-176	7-732
Disassemble (AVIM)	7-174	7-724
Install	7-178	7-740
Remove	7-172	7-717

	Task	Page
Test (AVIM)	7-177	7-734
Accumulator HP1323100		
Assemble (AVIM)	7-175	7-726
Disassemble (AVIM)	7-173	7-719
Install	7-178	7-740
Remove	7-172	7-717
Test (AVIM)	7-177	7-734
Remove	7-185	7-753
Valve, Check and Repressurizing		
Install	7-184	7-751
Remove	7-183	7-749
Valve, Pilot		
Install	7-182	7-748
Remove	7-181	7-746
Valve, Start		
Install	7-180	7-744
Remove	7-179	7-742
Module, Pressure Control		
Filter		
Install	7-157	7-682
Remove	7-156	7-680
Indicator, Filter		
Install	7-159	7-686
Remove	7-158	7-684
Install	7-153	7-674
Remove	7-152	7-672
Transmitter, Pressure		
Install	7-169	7-709
Remove	7-168	7-707
Valve, High Pressure Relief		
Install	7-165	7-697
Remove	7-164	7-695
Valve, PTU		
Install	7-171	7-713
Remove	7-170	7-711
Valves, Check		
Install	7-167	7-701
Remove	7-166	7-699
Valves, Engine Start		

	Task	Page
Install	7-155	7-678
Remove	7-154	7-676
Valves, Pilot		
Install	7-161	7-689
Remove	7-160	7-687
Valves, Three-Way		
Install	7-163	7-693
Remove	7-162	7-691
Module, Terminal Board - See Terminal Board Module		
Module, Utility Return Control		
Element, Filter		
Install	7-195	7-774
Remove	7-194	7-772
Install	7-188	7-758
Remove	7-187	7-756
Transfer Cylinder		
Assemble (AVIM)	7-191	7-764
Disassemble (AVIM)	7-190	7-762
Install	7-193	7-770
Remove	7-189	7-760
Test (AVIM)	7-192	7-766
Valve, Check, Transfer Cylinder		
Install	7-203	7-789
Remove	7-202	7-787
Valve, Filter Bypass		
Install	7-197	7-778
Remove	7-196	7-776
Valves, Filter Check		
Install	7-201	7-785
Remove	7-200	7-783
Monitor, External Power-External Power Monitor		
Mooring		
Paved Surface	1-26	1-86

	Task	Page
Unpaved Area	1-27	1-89
Motor, Power Transfer Unit Module - See Power Transfer Unit Module Motor		
Motor Pump, APU		
Coupling and Seal		
Install (AVIM)	7-145	7-645
Remove and Inspect (AVIM)	7-144	7-643
Motor Cargo Door Actuator - See Cargo Door Actuator Motor		
Motor, Trim or Servo (CCD)		
Inspect	11-156	11-639
Motor, Winch		
Install	7-248	7-921
Remove	7-247	7-919
Motor, Windshield Wiper - See Windshield Wiper System		
Mount, Aft Drive Shafting		
Inspect	6-13	6-41
Install	6-27	6-74
Remove	6-26	6-73
Mount, Forward Drive Shafting		
Inspect	6-13	6-41
Install	6-15	6-45
Remove	6-14	6-42
Mount, Manual Release, Forward and Aft Cargo Hook		
Install	16-39	16-203
Remove	16-38	16-201
Mount, Structure Bushings, Forward and Aft Cargo Hook		
Install	2-203.2	2-729
Remove	2-203.1	2-737
Mounds, APU Aft		
Inspect	15-5	15-26
Install Connecting Links	15-7	15-32
Remove Connecting Links	15-6	15-28
Mounds, APU Forward		
Replace	15-7.1	15-34
Mounds, Engine Aft		
Inspect	4-37	4-197
Install	4-39	4-206
Remove	4-36	4-194

	Task	Page
Repair	4-38	4-200
Mounts, Engine Forward		
Inspect	4-28	4-153
Install Adapter (Without 74)	4-35	4-181
Install Adapter (With 74)	4-35.1	4-187
Install Cap Assembly	4-34	4-177
Remove Adapter (Without 74)	4-29	4-156
Remove Adapter (With 74)	4-29.1	4-161
Remove Cap Assembly	4-27	4-149
Repair Adapter and Cap	4-32	4-169
Repair Lugs	4-31	4-168
Repair Structure	4-30	4-167
Replace Lug Bushings	4-33	4-172
N		
Neutral Rig Check	11-33	11-109
Nonmetallic Parts, Finish Organic	2-353	2-1236
Nose Access Door		
Install	2-144	2-486
Remove	2-138	2-469
Repair	2-141	2-477
Nose Bubble Window Panel		
Install	2-60	2-265
Prepare for Installation	2-59	2-262
Remove	2-58	2-260
Nose Cap, Rotary-Wing Blade		
Crack Repair	5.66.2	5-310
Unbonding Repair	5.66.1	5-305
Nozzle, Defroster, Jettisonable Door Window		
Install	13-35	13-111
Remove	13-34	13-109
Nozzle, Discharge, Fire Extinguisher		
Install	12-22	12-57
Remove	12-21	12-56
Nozzles, Water Wash, and Manifolds (With 74)		
Replace	4-141	4-464
Nuts, Use of	2-334	2-1165
NVG Blackout Curtain		
Install	2-108.2	2-401

	Task	Page
Remove	2-108.1	2-399
O		
Oil, MIL-L-7808		
Change to MIL-L-23699	4-91	4-348
Oil, MIL-L-23699		
Change to MIL-L-7808	4-91	4-348
Oil Change Requirements	1-87	1-316
Oil Cooler Assembly, Aft Transmission		
Bypass Valve		
Replace	6-144.1	6-512
Fan		
Install	6-144	6-509
Remove	6-141	6-507
Fan Duct Replacement	6-147	6-524
Oil Cooler		
Install	6-146	6-520
Remove	6-145	6-514
Outside Surface		
Repair	6-145.1	6-517
Oil Cooler Assembly, Combining Transmission		
Bypass Valve		
Replace	6-181.1	6-591
Exhaust Duct		
Inspect and Repair	6-181.2	6-593
Fan		
Inspect	6-182.1	6-598
Install (Without 66)	6-186	6-606
Install (With 66)	6-186.1	6-612
Remove	6-182	6-596
Fan Drive Shaft		
Inspect	6-182.1	6-598
Inspect Snubber	6-185	6-605
Install (Without 66)	6-186	6-606
Install (With 66)	6-186.1	6-612
Remove	6-182	6-596
Oil Cooler		
Install	6-188	6-622
Remove	6-187	6-616
Repair	6-187.1	6-619
Oil Cooler, Engine		

	Task	Page
Replace	4-96	4-359
Oil Cooler, Engine Transmission		
Install (Left)	6-215	6-703
Install (Right)	6-216	6-705
Remove (Left)	6-214	6-697
Remove (Right)	6-213	6-693
Repair Outside Surface	6-214.1	6-700
Replace Bypass Valve (Left)	6-213.1	6-695
Replace Bypass Valve (Right)	6-212.1	6-691
Oil Cooler Assembly, Forward Transmission		
Air Inlet Duct		
Install	6-122	6-468
Remove	6-121	6-466
Bypass Valve		
Replace	6-112.1	6-435
Diffuser		
Install	6-120	6-462
Remove	6-119	6-458
Fan Assembly		
Repair	6-114.1	6-445
Impeller		
Install	6-118	6-456
Remove	6-117	6-450
Oil Cooler		
Install	6-114	6-443
Remove	6-113	6-438
Outside Surface		
Repair	6-113.1	6-440
Shroud		
Install	6-116	6-449
Remove	6-115	6-448
Oil Filler		
Aft Transmission - See Transmission Components, Aft		
Combining Transmission - See Transmission Components, Combining		
Engine - See Engine		
Forward Transmission - See Transmission Components, Forward		
Oil Filter Strainer Element, Engine		
Replace	4-97	4-360

	Task	Page
Oil Level Check Light		
Install	9-93	9-302
Remove	9-92	9-300
Switch		
Install	9-95	9-307
Remove	9-94	9-305
Oil Manifold Tube, Vertical Hinge Pin		
Install (AVIM)	5-31	5-151
Remove (AVIM)	5-30	5-149
Oil Pressure Indicator, Engine - See Engine Oil Pressure Indicator		
Oil Pressure Indicator, Transmission - See Transmission Oil Pressure Indicator		
Oil Pressure Selector Switch, Transmission - See Transmission Oil Pressure Selector Switch		
Oil Pressure Switches, Transmission - See Switches, Transmission Oil Pressure		
Oil Pressure Transmitter, Engine (Without 74)		
Install	8-16	8-48
Remove	8-15	8-43
Oil Pressure Transducer, Transmission - See Transducer, Transmission Oil Pressure		
Oil Pump, Engine		
Install (No. 1 Engine)	4-93	4-352
Install (No. 2 Engine)	4-95	4-357
Remove (No. 1 Engine)	4-92	4-349
Remove (No. 2 Engine)	4-94	4-355
Oil Pump, Transmission, Auxiliary		
Aft Transmission		
Install	6-153	6-537
Remove	6-152	6-535
Forward Transmission		
Install	6-128	6-485
Remove	6-127	6-483
Oil Pump, Transmission, Main		
Aft Transmission		
Adjust	6-151	6-533
Install	6-150	6-532
Remove	6-149	6-531
Combining Transmission		
Adjust	6-172	6-576
Engine Transmission		
Adjust	6-200	6-660

	Task	Page
Forward Transmission		
Adjust	6-126	6-481
Install	6-125	6-479
Remove	6-124	6-477
Oil Seal, Forward Rotor Shaft		
Install	6-40	6-135
Remove	6-39	6-134
Oil Seals, Horizontal - See Seals, Oil, Horizontal Hinge Pin		
Oil Seals, Pitch Varying Housing - See Seals, Oil, Pitch Varying Housing		
Oil Seals, Vertical Hinge Pin - See Seals, Oil, Vertical Hinge Pin		
Oil Tanks, Pitch Bearing		
Inspect	5-18	5-97
Inspect for Leakage	5-6.1	5-36
Install	5-21	5-103
Install Sight Indicator	5-13	5-81
Remove	5-19	5-98
Remove Sight Indicator	5-12	5-78
Repair (AVIM)	5-20	5-100
Oil Tank, Rotor Hub		
Inspect	5-14	5-85
Inspect for Leakage	5-6.1	5-36
Install	5-17	5-93
Install Sight Indicator	5-11	5-77
Remove	5-15	5-87
Remove Sight Indicator	5-10	5-74
Repair (AVIM)	5-16	5-90
Oil Tanks, Vertical Hinge Pin		
Inspect for Leakage	5-6.1	5-36
Install	5-29	5-143
Install Sight Gauge	5-13.1	5-82
Remove	5-28	5-141
Remove Sight Gauge	5-13.1	5-82
Oil Temperature Indicator, Engine - See Engine Oil Temperature Indicator		
Oil Temperature Indicator, Transmission - See Transmission Oil Temperature Indicator		
Oil Temperature Selector Switch, Transmission - See Transmission Oil Temperature Selector Switch		
Oil Temperature Transmitter, Engine		
Replace	8-18	8-56
Oil Temperature Transmitter, Transmission - See Transmitter, Transmission Oil Temperature		

	Task	Page
Out-Of-Phase Switch, Power Steering - See Power Steering Out-Of-Phase Switch		
Output Shaft Seal		
Replace	4-23	4-145
Overhaul and Retirement Schedule	1-91	1-326
Overhead Panel		
Install	9-98	9-312
Remove	9-97	9-310
Overhead Panel Components		
Lamps		
Replace (Without 17)	9-96	9-309
Panels		
Install (With 17)	9-98.2	9-329
Install (Without 17) and (Without 74)	9-100	9-388
Remove (With 17)	9-98.1	3-314
Remove (Without 17) and (Without 74)	9-99	9-353
Repair (With 17)	9-98.3	9-345
Module (With 17)		
Install	9-98.5	9-352
Remove	9-98.4	9-351
Potentiometer/Control Transformer/Rotary Switch (With 17)		
Install	9-101.2	9-407
Remove	9-101.1	9-404
Replace Fuses (Control Transformer)	9-104.1	9-420
Relay (With 17)		
Install	9-123.2	9-471
Remove	9-123.1	9-469
Transformer (With 17)		
Install	9-123.2	9-471
Remove	9-123.1	9-469
Variable Resistor (With 17)		
Install	9-102	9-412
Remove	9-101	9-402

P

P3 Signal Line, Leak Test FADEC	4-159	4-517
Pallet, Control, STA 95.00 - See Control Pallet STA 95.00		
Pallet, Control STA 120.00 - See Control Pallet STA 120.00		
Palmer 611 Compound, Application of (AVIM)	2-340	2-1187
Panel AFCS - See AFCS Panel		

	Task	Page
Panel and Pan, Emergency Exit Light		
Install	17-10	17-25
Remove	17-9	17-23
Panel, Cabin Floor - See Cabin Floor Panel		
Panel, Emergency Power - See Emergency Power Panel (Without 74)		
Panel, FADEC Control (With 74)		
Install	4-151	4-494
Remove	4-150	4-493
Panel, FADEC Relay (With 74)		
Install	4-155	4-511
Remove	4-154	4-510
Panel, Generator Control - See Generator Control Panel		
Panel, Hoist/Cargo Hook - See Hoist/Cargo Hook Panel		
Panel, Hoist Operator's - See Hoist Operator's Panel		
Panel, Hydraulic Maintenance		
Components		
Install	8-101	8-319
Remove	8-100	8-309
Install	8-102	8-330
Instruments, Clamp Mounted		
Install	8-98	8-306
Remove	8-97	8-304
Remove	8-99	8-308
Panel, Instrument		
Center		
Install	8-108	8-350
Remove	8-107	8-347
Copilot		
Install	8-106	8-343
Remove	8-105	8-339
Pilot		
Install	8-104	8-335
Remove	8-103	8-331
Panel, Isolation, Fuel Tank - See Isolation Panel, Fuel Tank		
Panel, Jettisonable Door Sliding Window - See Jettisonable Door Sliding Window Panel		
Panel, Master Caution - See Master Caution Panel		
Panel, Overhead - See Overhead Panel		
Panel, Power Assurance and Test Switch (With 74)		
Install	4-157	4-513

	Task	Page
Remove	4-156	4-512
Panel, Status, Flare Dispenser - See Status Panel, Flare Dispenser		
Panels, Access - See Access Panels		
Panels, Fuel Pod		
Inspect	2-182	2-601
Install	2-188	2-683
Prepare for Installation	2-185.1	2-609
Remove	2-185	2-606
Pans, Drip - See Drip Pans		
Paratroop and Cargo Drop Equipment	16-42	16-212
Paratroop Anchor Line		
Assemble	16-46	16-220
Disassemble	16-45	16-218
Inspect	16-43	16-214
Install	16-47	16-222
Remove	16-44	16-216
Park Helicopter	1-25	1-84
Parking Brake Valve - See Brake Valve, Parking		
Payload Module - See Countermeasures Dispenser System Payload Module		
Permaswage Hydraulic System Plumbing, Repair - See Hydraulic System Plumbing, Repair, Permaswage		
Phase Rotary-Wing Blades	6-28	6-77
Pilot Valve, APU Start Solenoid		
Install	7-182	7-748
Remove	7-181	7-746
Pilot Valve, Power Control Module - See Power Control Module Pilot Valve		
Pilot Valve, Power Transfer Unit Module - See Power Transfer Unit Module Pilot Valve		
Pilot Valves, Pressure Control Module		
Install	7-161	7-689
Remove	7-160	7-687
Pin, Horizontal Hinge, (Horizontal Hinge Pin and Bearing)		
Inspect	5-45	5-193
Inspect and Repair Pitch-Varying Shaft Bore	5-44.1	5-191
Install	5-46	5-197
Remove	5-44	5-187
Pin Rigging Damaged		
Inspect (Removed)	11-18	11-75
Remove from First Stage Controls	11-19	11-76
Remove from Second Stage Controls	11-20	11-79
Remove from Thrust Controls	11-17	11-68

	Task	Page
Pipe, Heater Exhaust		
Install	13-21	13-79
Remove	13-20	13-77
Pitch and Roll Control Stick Grip		
Assemble (AVIM)	9-136	9-539
Disassemble (AVIM)	9-135	9-537
Install	9-137	9-544
Remove	9-134	9-535
Test (AVIM)	9-136.1	9-541
Pitch and Roll Pallet Idler Bellcranks Rigging - See Rig Pallet Pitch and Roll Idler Bellcranks		
Pitch Viscous Damper Arm - See Yaw, Thrust, Roll, or Pitch Viscous Damper Arms		
Install	11-139	11-603
Remove	11-138	11-602
Pitch, Roll or Yaw Balance Spring		
Install	11-135	11-596
Remove	11-134	11-593
Pitch or Roll Balance Spring Adjust	11-137	11-599
Pitch Balance Spring Bracket		
Install	11-134.2	11-595
Remove	11-134.1	11-594
Pitch Bearing Oil Tanks - See Oil Tanks, Pitch Bearing		
Pitch CCDA Actuator		
Assemble (AVIM)	11-161	11-654
Disassemble (AVIM)	11-160	11-651
Install	11-162	11-660
Remove	11-159	11-649
Test - Bench (AVIM)	11-279	11-1156
Pitch Control Position Transducer - See Transducer, Pitch Control Position		
Pitch Control Travel Check	11-38	11-144
Pitch Housing Oil Tank Sight Indicator - See Sight Indicator, Pitch Housing Oil Tank		
Pitch Idler Bellcrank, Control Pallet STA 120.00 - See Control Pallet STA 120.00		
Pitch Idler Bellcrank		
Pitch or Roll Intermediate Bellcranks		
Clean - See Clean Flight Control System		
Inspect - Corrosion - See Corrosion Bellcranks, Inspect		
Inspect - General	11-10	11-45
Install	11-181	11-717
Remove	11-180	11-716
Repair - Finish - See Bellcrank and Arm Finish Repair		
Repair - General - See Bellcrank and Control Arms Repair		

	Task	Page
Pitch Link Boot - See Boot, Pitch Link		
Pitch Link Lockpins		
Install (Power Off)	5-96.1	5-579
Remove (Power Off)	5-96.2	5-581
Pitch Links		
Adjust	5-94	5-566
Bearing Inspection Teflon (Installed)	5-97.1	5-585
Bearing Inspection Elastomeric (Installed)	5-97.2	5-590
Bolt Replacement	5-94.1	5-570
Bolt Torque Check	5-99.1	5-603
Correct for Autorotation % Rpm	5-139	5-779
Install	5-99	5-600
Prepare for Service	5-96	5-575
Prepare for Storage or Shipment	5-95	5-573
Remove	5-97	5-583
Repair	5-98	5-592
Pitch Overtravel Stop Rigging	11-44	11-184
Pitch, Roll, or Yaw Travel Quadrants Cockpit		
Install	11-24	11-88
Remove	11-25	11-91
Pitch Shaft Wear Sleeve - See Wear Sleeve, Pitch Shaft		
Pitch, Roll or Yaw Spring Assembly		
Adjust (AVIM)	11-145	11-615
Assemble	11-143	11-609
Disassemble	11-142	11-607
Test (AVIM)	11-144	11-613
Pitch or Roll Spring Assemblies		
Install	11-147	11-620
Remove	11-141	11-606
Pitch Varying Housing - See Housing, Pitch Varying		
Pitch Varying Housing Oil Seals - See Seals, Oil, Pitch Varying Housing		
Pitch Viscous Damper Connecting Link - See Thrust or Pitch Viscous Damper Connecting Link		
Pitot Static and Side Slip Sensing System		
Drain	8-25	8-81
Inspect	8-24	8-80
Purge	8-26	8-83
Pitot Tube, No. 1 or No. 2		
Install	8-30	8-105
Remove	8-27	8-100

	Task	Page
■ Pitot Tube Support, No. 1 or No. 2		
Install	8-29	8-103
Remove	8-28	8-101
Pivoting and Swiveling Servocylinders		
Inspect	7-123	7-539
Inspect Bearing Play	7-128	7-570
Install		
Aft Pivoting	7-132	7-594
Aft Swiveling	7-134	7-602
Forward Pivoting	7-131	7-589
Forward Swiveling	7-133	7-598
Leakage Check (Control Valve)	7-123.2	7-546
Pressure (Jam) Indicator Installation	7-123.4	7-552
Pressure (Jam) Indicator Removal	7-123.3	7-550
Remove		
Aft Pivoting	7-125	7-558
Aft Swiveling	7-127	7-566
Forward Pivoting	7-124	7-554
Forward Swiveling	7-126	7-562
Repair (AVIM)		
Pivoting	7-129	7-577
Swiveling	7-130	7-584
■ Test (Jam) Indications (on Aircraft)	7-123.1	7-543
Torque Check, Cylinder Nut	7-129.1	7-582
■ Plastic Windshield and Window Repair	2-42	2-216
Plastic Windshield, Center - See Windshield, Plastic, Center		
Plastic Windshield, Pilot or Copilot - See Windshield, Plastic, Pilot or Copilot		
Plates, Support, Suppressive Fire System - See Support Plates, Suppressive Fire System		
Platform, Work, Pylon - See Work Platform, Pylon		
■ PLT LTG Overhead Panel - See Overhead Panel Components		
Plumbing, Hydraulic System - See Hydraulic System Plumbing		
Pods, Fuel		
General Repair	2-183	2-604
Major Damage (AVIM)	2-186	2-612
Minor Damage	2-184	2-605

	Task	Page
Pods, Fuel - See Fuel Pods		
Polyurethane Topcoatings, Application/Repair	2-350.1	2-1206
Ports, Sideslip Sense		
Install	8-32	8-109
Remove	8-31	8-107
Position Light or Troop/Jump Signal Dimming Resistor		
Install	9-123	9-467
Remove	9-122	9-465
Position Transducer Assembly, Thrust Control (With 74)		
Install and Rig	4-153	4-498
Remove	4-152	4-495
Power Assurance Panel and Test Switch (With 74)		
Install	4-157	4-513
Remove	4-156	4-512
Power Control Module, Hydraulic Flight Control (Components)		
Accumulator		
Assemble (2770529) (AVIM)	7-49	7-236
Assemble (AD-A620-1D340) (AVIM)	7-49.1	7-242
Assemble (60910) (AVIM)	7-49.2	7-246
Disassemble and Inspect (2770529) (AVIM)	7-48	7-227
Disassemble and Inspect (AD-A620-1D340) (AVIM)	7-48.1	7-230
Disassemble and Inspect (60910) (AVIM)	7-48.2	7-233
Install	7-51	7-254
Remove	7-47	7-224
Test (2770529/AD-A620-1D340 or 60910) (AVIM)	7-50	7-249
Service	1-63	1-242
Filter Check Valve		
Install	7-53	7-259
Remove	7-52	7-257
Filter Element		
Install	7-34	7-185
Remove	7-33	7-183
Filter Change Switch		
Install	7-36	7-190
Remove	7-35	7-188
Filter Relief Valve		
Install	7-38	7-195
Remove	7-37	7-193

	Task	Page
High Pressure Check Valve		
Install	7-40.2	7-207
Remove	7-40.1	7-204
High Pressure Relief Valve		
Install	7-40	7-200
Remove	7-39	7-197
Miscellaneous Check Valves		
Install	7-54.2	7-267
Remove	7-54.1	7-263
Power Control Module, Hydraulic Flight Control		
Install (No. 1 Module)	7-30	7-176
Install (No. 2 Module)	7-32	7-181
Remove (No. 1 Module)	7-29	7-174
Remove (No. 2 Module)	7-31	7-179
Pilot Valve		
Install	7-57	7-274
Remove	7-56	7-272
Pressure Switch		
Install	7-44	7-218
Remove	7-43	7-216
Pressure Transmitter		
Install	7-46	7-222
Remove	7-45	7-220
Pump Change Indicator		
Install	7-55	7-270
Remove	7-54	7-261
Three-Way Valve		
Inspect and Repair	7-42.1	7-214
Install	7-42	7-212
Remove	7-41	7-210
Power Distribution Panels		
Circuit Breakers		
Install	9-11	9-43
Remove	9-10	9-41
Inspect	9-9.1	9-40
Install	9-9	9-36
Remove	9-8	9-33
Power, External		
Electric	1-37	1-132
Hydraulic	1-38	1-134

	Task	Page
Power Panel, Emergency - See Emergency Power Panel (Without 74)		
Power Receptacle, DC - See DC Power Receptacle		
Power Steering	7-290	7-1077
Power Steering Assembly		
Install	7-300	7-1098
Remove	7-299	7-1095
Power Steering Assembly Pressure Tube		
Install (AVIM)	7-302	7-1102
Remove and Inspect (AVIM)	7-301	7-1101
Power Steering Control Box		
Adjust (on Aircraft) (AVIM)	9-146.1	9-591
Assemble (AVIM)	9-144	9-575
Disassemble (AVIM)	9-143	9-569
Install	9-146	9-590
Remove	9-142	9-568
Test and Adjust (AVIM)	9-145	9-582
Power Steering Out-Of-Phase Switch		
Adjust	7-307	7-1111
Install	7-306	7-1109
Remove	7-305	7-1107
Power Steering Servo Valve		
Install	7-304	7-1106
Remove	7-303	7-1104
Power Steering and Swivel Lock Check Valve		
Install	7-296	7-1090
Remove	7-295	7-1088
Power Steering and Swivel Lock Control Valves		
Install	7-294	7-1087
Remove	7-293	7-1085
Power Steering and Swivel Lock Module		
Install	7-292	7-1083
Remove	7-291	7-1081
Power Steering and Swivel Lock Module Accumulator		
Assemble (60910) (AVIM)	7-176	7-732
Disassemble and Inspect (60910) (AVIM)	7-174	7-724
Install	7-298	7-1093
Remove	7-297	7-1091
Service	1-66	1-252

	Task	Page
Test (60910) (AVIM)	7-177	7-734
Power Supply, Engine Torquemeter (Without 74)		
Install	8-22	8-67
Remove	8-20	8-64
Test (AVIM)	8-21	8-65
Power Supply, Fuel Flow System		
Install	8-80.4	8-220
Remove	8-80.3	8-219
Power Supply, No. 1 or No. 2 Torque Signal Processor, Engine (With 74)		
Install	8-22.2	8-70
Remove	8-22.1	8-69
Power Transfer Unit Module, No. 1 or No. 2		
Install	7-59	7-278
Remove	7-58	7-276
Power Transfer Unit Module Components		
Check (Isolation) Valve		
Install	7-63	7-288
Remove	7-62	7-286
Flow Limiter		
Install	7-67	7-297
Remove	7-66	7-295
Motor		
Install	7-77	7-319
Remove	7-73	7-311
Shaft Seal, Motor		
Install (570973) (AVIM)	7-75	7-315
Remove and Inspect (570973) (AVIM)	7-74	7-313
Test (570973) (AVIM)	7-76	7-317
Pilot Valve		
Install	7-65	7-292
Remove	7-64	7-290
Pump		
Install	7-72	7-309
Remove	7-68	7-300
Shaft Seal, Pump		
Install (590974)	7-70	7-305
Remove and Inspect (590974)	7-69	7-302
Test (590974) (AVIM)	7-71	7-307

	Task	Page
Valve, Three-Way		
Install	7-61	7-283
Remove	7-60	7-281
Power Turbine Actuator (Without 74)		
Install	4-139	4-452
Remove	4-138	4-450
Power Turbine Inlet Temperature (PTIT) Indicator		
Install	8-87	8-278
Remove	8-86	8-276
Test	8-2	8-16
Power Turbine Linkage - See Linkage, Power Turbine		
Powerplant (Also See Engine)		
Assemble	4-12	4-93
Change Oil	4-91	4-348
Check Coastdown Time	4-5	4-35
Check After Excessive G-Force Load (Without 74)	4-6	4-37
Check After Excessive G-Force Load (With 74)	4-6.1	4-39
Check Suspected Compressor Stall	4-8	4-43
Depreserve (With 74)	4-158	4-514
Description	4-1	4-2
Disassemble (Without 74)	4-11	4-59
Disassemble (With 74)	4-11.1	4-69
Gas Producer Control System Adjustment (Without 18)	4-102	4-372
Gas Producer Control System Adjustment (With 18)	4-102.1	4-378
Health Indicator Test (Hit) (Without 74)	4-2	4-12
Initial Runup	4-4	4-33
Inspection (After Check Run)	4-9	4-44
Install	4-13	4-108
Power Turbine (N2) Overspeed (Without 74)	4-7	4-41
Power Turbine (N2) Overspeed (With 74)	4-7.1	4-42
Remove (Without 74)	4-10	4-45
Remove (With 74)	4-10.1	4-52
Turbine Engine Analysis Check (TEAC) (Without 74)	4-3	4-25
Vibration Test (Without 74)	4-14	4-118
Powerplant Components (Without 74)		
Gas Producer Actuator (Without 74)		
Install	4-109	4-394
Remove	4-108	4-392
Gas Producer Control Box (Without 74)		

	Task	Page
Install	4-107	4-391
Remove	4-106	4-390
Gas Producer Control Linkage - See Linkage, Gas Producer (Without 74)		
Oil Pump		
Install (No. 1 Powerplant)	4-93	4-352
Install (No. 2 Powerplant)	4-95	4-357
Remove (No. 1 Powerplant)	4-92	4-349
Remove (No. 2 Powerplant)	4-94	4-355
Precheck Panel, Fuel - See Fuel Precheck Panel		
Preparation of Bonding Surfaces - See Bonding Surfaces, Preparation of		
Preparation for Storage or Shipment	1-4	1-1
Prepare for Flushing Pressure Lines, Flight Control Hydraulic System - See Flush Flight Control Hydraulic System, Prepare for Flushing Pressure Lines		
Prepare for Flushing Return Lines, Flight Control Hydraulic System - See Flush Flight Control Hydraulic System, Prepare for Flushing Return Lines		
Prepare System After Flushing Pressure Lines, Flight Control Hydraulic System - See Flush Flight Control Hydraulic System, Prepare System After Flushing Pressure Lines		
Prepare System After Flushing Return Lines, Flight Control Hydraulic System - See Flush Control Hydraulic System, Prepare System After Flushing Pressure Lines		
Preservation, Engine Compressor (With 74)	4-146	4-482
Preservation - See Storage		
Preservation, Auxiliary Power Unit (APU)	15-2	15-6
Pressure Control Module - See Module, Pressure Control		
Pressure Indicator, Hydraulic - See Indicator, Hydraulic Pressure		
Pressure Reducer, Lower Controls Module - See Lower Controls Module Pressure Reducer		
Pressure Refueling Adapter		
Assemble (2650266)	10-87.2	10-407
Disassemble (2650266)	10-87.1	10-405
Install	10-88	10-411
Remove	10-87	10-403
Pressure Refueling System Leak Test	10-119	10-509
Pressure Switch, Power Control Module - See Power Control Module Pressure Switch		
Pressure Switch, Utility System		
Install	7-167.2	7-705
Remove	7-167.1	7-703
Pressure Switches, Fuel System		
Auxiliary Fuel Pump		
Install	10-86	10-401
Remove	10-85	10-399
No. 1 System		
Install	10-106	10-473

	Task	Page
Remove	10-105	10-471
No. 2 System		
Install	10-108	10-476
Remove	10-107	10-475
Pressure Test, Vent System	10-117	10-499
Pressure Transducer Adjustment		
Sideslip, Airspeed or Barometric	11-276.1	11-1069
Pressure Transmitter - Power Control Module - See Power Control Module Pressure Transmitter		
Priming Engine Fuel Control (Without 74)	10-122	10-561
Processor, Cruise Guide Signal		
Install	8-42	8-128
Remove	8-41	8-127
Processor/Power Supply, Torque Signal, Engine (With 74)		
Install	8-22.2	8-70
Remove	8-22.1	8-69
Programmer, Countermeasures Dispenser - See Countermeasures Dispenser System Programmer		
Protective Covers	1-32	1-111
Proximity Switch Assembly, Aft Landing Gear		
Switch, Target, and Adjuster Link		
Install	3-55	3-143
Remove	3-54	3-137
Switch		
Adjust	3-56	3-146
Switch Bracket		
Replace	3-54.1	3-140
Pump Change Indicator, Power Control Module - See Power Control Module Pump Change Indicator		
Pump, Hand, Hydraulic - See Handpump, Hydraulic		
Pump, Power Transfer Unit Module - See Power Transfer Unit Module Pump		
Pump, Powerplant Fuel Boost		
Install (Without 74)	4-18	4-136
Install (With 74)	4-18.1	4-138
Remove (Without 74)	4-17	4-133

Remove (With 74)	4-17.1	4-134
Pump, Powerplant Oil		
Install No. 1	4-93	4-352
Install No. 2	4-95	4-357
Remove No. 1	4-92	4-349
Remove No. 2	4-94	4-355
Pump, Utility Hydraulic		
Install	7-151	7-669
Remove	7-150	7-666
Test (AVIM)	7-26	7-164
Pumps, Flight Control Hydraulic - See Flight Control Hydraulic Pumps		
Purging Fuel Tanks		
With Air	10-3	10-27
With Inert Gas	10-2	10-24
Pylon and Cabin Aft Linkage Rigging - See Rig Procedures - Aft Pylon and Cabin Linkage		
Pylon, Aft		
Install (Aft Shaft Installed)	2-308	2-1075
Install (Aft Shaft Removed)	2-309	2-1090
Remove (Aft Shaft Installed)	2-306	2-1052
Remove (Aft Shaft Removed)	2-307	2-1064
Repair	2-304	2-1029
Minor Repair	2-303	2-1028
Repair (AVIM)	2-305	2-1051
Pylon Aft Crown Fairing Repair	2-299	2-1022
Pylon, Aft, Equipment Support Structure - See Equipment Support Structure, Aft Pylon		
Pylon Bellcranks		
Clean - See Clean Flight Control System		
Inspect (Corrosion) - See Corrosion Bellcranks, Inspect		
Inspect (General)	11-10	11-45
Install		
Left Lower STA 534.00	11-257	11-988
Left Upper	11-265	11-1004
Right Lower STA 534.00	11-259	11-992
Right Upper	11-267	11-1009
Remove		
Left Lower STA 534.00	11-256	11-986
Left Upper	11-264	11-1002
Right Lower STA 534.00	11-258	11-990
Right Upper	11-266	11-1007

	Task	Page
Repair of Finish - See Bellcrank and Arm Finish Repair		
Repair (General) - See Bellcrank and Control Arms Repair		
Rigging	11-57	11-259
Pylon Damage, Inspection - See Fuselage and Pylon Damage, Inspection		
Pylon Deck Drain Line Replacement	2-304.1	2-1049
Pylon Forward Crown Fairing		
Install	2-295	2-1008
Remove	2-293	2-1002
Repair	2-294	2-1005
Pylon Leading Edge Hinged Fairing (Clamshell Doors) - See Hinged Fairing, Pylon Leading Edge (Clamshell Doors)		
Pylon Lower Hinged Fairing		
Install	2-285	2-967
Remove	2-284	2-965
Pylon Mid Crown Fairing		
Install	2-298	2-1018
Remove	2-296	2-1011
Repair	2-297	2-1015
Q		
Quadrant Travel, Pitch, Roll or Yaw, Cockpit - See Cockpit Travel Quadrant, Pitch, Roll, or Yaw		
Quality Assurance/Quality Control	1-5	1-1
Quill Shaft Inspection, Engine Transmission	6-101	6-405
R		
Radar Altimeter - See Altimeter, Radar		
Rails, Seat, Pilot or Copilot		
Install	2-113	2-410
Remove	2-112	2-409
Rainshield - See Weather Protective Cover		
Ramp, Cargo		
Description	7-135	7-608
Install	2-255	2-892
Remove	2-252	2-869
Repair	2-254	2-873
Minor Damage	2-250	2-848
Reparable Damage	2-251	2-849
Reparable Damage (AVIM)	2-253	2-872
Repair Nomex Composite Skin (AVIM) (With 22)	2-251.1	2-850
Theory of Operation	7-135	7-608
Ramp Components, Cargo		

	Task	Page
Actuating Cylinder		
Adjust	7-274	7-1022
Install	7-273	7-1017
Remove	7-271	7-1012
Repair (AVIM)	7-272	7-1014
Control Valve		
Assemble (AVIM) (145HS775) (With 65)	7-268.1	7-985
Assemble (AVIM) (114HS111) (Without 65)	7-268	7-981
Disassemble and Inspect (AVIM) (114HS111) (Without 65)	7-267	7-969
Disassemble and Inspect (AVIM) (145HS775) (With 65)	7-267.1	7-973
Install	7-270	7-1009
Remove	7-266	7-967
Test (AVIM) (114HS111) (Without 65)	7-269	7-993
Test (AVIM) (145HS775) (With 65)	7-269.1	7-999
Extension Support Assembly Stowage Provisions (With 19)	2-244.1	2-835
Floor Panels		
Install	2-249	2-846
Remove	2-247	2-841
Repair	2-248	2-842
Gate		
Install	2-257.2	2-902
Remove	2-257.1	2-900
Rearview Mirror, Cockpit - See Mirror, Rearview, Cockpit		
Receptacle, AC Power		
Install	9-48	9-144
Remove	9-47	9-142
Receptacle, DC Cabin Utility - See DC Cabin Utility Receptacle		
Receptacle, DC Power - See DC Power Receptacle		
Records, Maintenance	1-2	1-1
Rectifiers, Transformer - See Transformer Rectifiers		
Reel, Inertia - See Inertia Reel		
References		
Appendix A		A-1
Refitting of Fittings, Hoses, and Tubing (General)	10-38	10-203
Refueling		
Gravity	1-51.1	1-201
Single Point	1-51	1-192
Refueling Adapter, Pressure - See Pressure Refueling Adapter		
Relay, Battery - See Battery Relay		

	Task	Page
Relay Box, Dual Cargo Hook Release - See Dual Cargo Hook Release Relay Box		
Relay Box, Emergency Hook Release - See Emergency Hook Release Relay Box		
Relay Box, Heater Control		
Install	13-57	13-167
Relays		
Install	13-56	13-164
Remove	13-55	13-161
Remove	13-54	13-160
Relay, Bus Tie - See Bus Tie Relay		
Relay, Engine Trim (Without 74)		
Install	4-124	4-428
Remove	4-123	4-427
Relay, Essential DC Bus - See Essential DC Bus Relay		
Relay, External Power (Contactor)		
Replace	9-38.1	9-121
Relay, Flare Dispenser		
Install	16-59	16-249
Remove	16-58	16-248
Relay, Fuel Pump		
Install	10-116	10-493
Remove	10-115	10-491
Relay, Heater Fan - See Heater Fan Relay		
Relay Panel, FADEC (With 74)		
Install	4-155	4-511
Remove	4-154	4-510
Relay, Reverse Current Cutout - See Reverse Current Cutout Relay		
Relay, Switched Battery Bus - See Switched Battery Bus Relay		
Relay, Transformer Fail - See Transformer Fail Relay		
Relays, Cabin and Ramp Lighting - See Cabin and Ramp Lighting Relays		
Relays, Emergency Engine Trim (Without 74)		
Install	4-126	4-430
Remove	4-125	4-429
Relays, Heater Control		
Install	13-56	13-164
Remove	13-55	13-161
Relays, Windshield Anti-Icing		
Install	12-6	12-17
Remove	12-5	12-14

	Task	Page
Release, Manual, Forward, and Aft Cargo Hook - See Manual Release, Forward and Aft Cargo Hook		
Relief Valve, Flight Control Reservoir/Cooler - See Flight Control Reservoir/Cooler Relief Valve		
Relief Valve, High Pressure, Power Control Module - See Power Control Module High Pressure Relief Valve		
Relief Valve, Hoist Pressure		
Install	7-254	7-933
Remove	7-253	7-931
Relief Valve, Integrated Lower Control Actuator (ILCA) - See Integrated Lower Control Actuator (ILCA) Relief Valve		
Relief Valve, High Pressure, Pressure Control Module		
Install	7-165	7-697
Remove	7-164	7-695
Relief Valve, Low Pressure, Utility Reservoir/Cooler		
Install	7-207	7-797
Remove	7-206	7-795
Relief Valve, Utility Accumulator		
Install	7-218.4	7-837
Remove	7-218.3	7-835
Remote Positioning Control Box (Without 74)		
Install	4-128	4-432
Remove	4-127	4-431
Remove Lower Controls actuator Structural Manifold Check Valve Assembly	7-103.1	7-490
Reparable Damage, Classification Of	2-7	2-29
Reporting Equipment Improvement Recommendations (EIR)	1-6	1-1
Reports, Maintenance	1-2	1-1
Rescue Hatch Lower Door		
Assemble	2-195	2-702
Disassemble	2-194	2-698
Install	2-203	2-725
Remove	2-193	2-696
Rescue Hatch Lower Door Components		
Gearbox		
Assemble (AVIM)	2-199	2-715
Disassemble (AVIM)	2-197	2-709
Inspect (AVIM)	2-198	2-712
Install	2-200	2-719
Remove	2-196	2-707
Links, Rigid or Welded		
Install	2-202	2-723
Remove	2-201	2-721

	Task	Page
Reservoir/Cooler, Flight Control - See Flight Control Reservoir/Cooler		
Reservoir/Cooler, Utility Hydraulic System		
Assemble (AVIM)	7-215	7-815
Bleed	7-335	7-1231
Disassemble and Inspect (AVIM)	7-214	7-812
Fluid Sampling - See Hydraulic Fluid Sampling		
Install	7-218	7-827
Remove	7-212	7-807
Test (AVIM)	7-217	7-820
Reservoir/Cooler Components, Utility Hydraulic System		
Bulb, Temperature		
Install	7-209	7-801
Remove	7-208	7-799
Switch, Temperature		
Install	7-211	7-805
Remove	7-210	7-803
Valve, Bleed/Relief		
Install	7-216	7-819
Remove	7-213	7-810
Valve, Cooler Relief		
Install	7-207	7-797
Remove	7-206	7-795
Resistors, Engine Droop Eliminator (Without 74)		
Adjust	4-118	4-411
Assemble	4-121	4-422
Disassemble	4-120	4-420
Install and Rig	4-122	4-424
Remove	4-119	4-419
Resistors, Engine Trim (Without 74)		
Adjust	4-129	4-433
Install	4-131	4-438
Remove	4-130	4-436
Restore Transparent Plastic Finish	2-345	2-1194
Restraint Equipment, Inspection	2-117.1	2-419
Restrictor, Airspeed Indicator		
Adjust	8-37	8-119
Replace	8-36	8-118
Test	8-35	8-116

	Task	Page
Retaining Nut Torque Check, Rotary-Wing Head	5-9.1	5-68
Retirement Schedule - See Overhaul and Retirement Schedule		
Reverse Current Cutout Relay		
Install	9-13	9-48
Remove	9-12	9-46
Rig Check, Neutral	11-33	11-109
Rig Check Forward and Aft, LCT Actuator	11-40	11-155
Rig Pin, Damaged, Removal of		
First Stage Controls	11-19	11-76
Second Stage Control	11-20	11-79
Thrust Control	11-17	11-68
Rig Position Check	11-32	11-103
Rig Procedures		
Aft Cabin and Pylon Linkage	11-57	11-259
Bellcranks		
First and Second Stage	11-51	11-216
Forward Upper	11-53	11-234
Pallet Pitch and Roll Idler Bellcranks	11-49	11-205
Pallet Thrust and Yaw Idler Bellcranks	11-48	11-200
Blades, Rotary-Wing, Aft	11-58	11-269
Blades, Rotary-Wing, Forward	11-55	11-250
Cockpit Control Assembly - See Cockpit Control Assembly (Pilot's or Copilot's)		
Cockpit Transfer Bellcranks - See Cockpit Control Transfer Bellcranks		
Dash Actuator for Hover	11-50	11-209
Flight Control System (General)	11-4	11-11
Fuel Control - See Rig Gas Producer (N1) Control Linkage		
Gas Producer (N1) Control Linkage, Powerplant (Without 74)	4-113	4-399
Ilca Input Connecting Links	11-47	11-196
Indicator, Pitch Control Position - See Cockpit Control Stick Position Indicator		
LCT Actuator, Forward and AFT	11-40	11-155
Pitch Overtravel Stop	11-44	11-184
Power Turbine (N2) Linkage (Powerplant) (Without 74)	4-140	4-454
Forward or Aft Swashplate and Servocylinders	11-54	11-240
Thrust Control	11-43	11-177
Tunnel Controls Linkage	11-56	11-255
Rigging Tools, Cockpit		
Install	11-22	11-82

	Task	Page
Remove	11-23	11-85
Right Upper Pylon Connecting Link - See Connecting Link, Right Upper Pylon		
Rivets	2-326	2-1150
Rod End Bearing Lubrication (Antifriction)	11-3	11-9
Roll and Yaw Travel Combined Check	11-37	11-139
Roll Viscous Damper Arm - See Yaw, Thrust, Roll or Pitch Viscous Damper Arms		
Roll Balance Spring - See Pitch, Roll or Yaw Balance Spring		
Roll Controls Travel Check	11-36	11-134
Roll Erect Cutout Relay		
Assemble	11-278.3	11-1153
Disassemble	11-278.2	11-1151
Install	11-278.4	11-1155
Remove	11-278.1	11-1150
Roll Idler Bellcrank Control Pallet, STA 120.00 - See Control Pallet STA 120.00 Roll Idler Bellcrank		
Roll Intermediate Bellcranks - See Pitch or Roll Intermediate Bellcranks		
Roll Magnetic Brake		
Adjust (AVIM) (R460M39-3 or R460M39-4)	11-151	11-628
Install	11-153	11-632
Remove	11-149	11-624
Test (AVIM)	11-150	11-625
Roll or Yaw Control Position Transducer - See Transducer, Roll or Yaw Control Position		
Roll, Pitch, or Yaw Travel Quadrant Cockpit - See Cockpit Travel Quadrant Pitch, Roll or Yaw		
Roll Spring Assembly - See Pitch, Roll or Yaw Spring Assembly		
Roll Spring Assembly - See Pitch or Roll Spring Assemblies for Install and Removal		

	Task	Page
Roll Viscous Damper Connecting Link		
Install	11-128	11-582
Remove	11-127	11-581
Rosan Fasteners		
Locked-in Stud Replacement (AVIM)	1-15	1-21
Screw-Thread Insert Replacement (AVIM)	1-16	1-27
Rosan Fittings		
Adapter and Reducers Replacement	7-6	7-45
Inserts - See Rosan Fasteners		
Studs - See Rosan Fasteners		
Rotary-Wing Aft Blades, Rig - See Blades, Rotary-Wing Aft		
Rotary-Wing Blade Erosion Cap - See Erosion Cap, Rotary-Wing Blades		
Rotary-Wing Blade Shock Absorber - See Shock Absorber, Rotary-Wing Blade		
Rotary-Wing Blade Tracking and Balancing - See Tracking and Balancing, Rotary-Wing Blades		
Rotary-Wing Blades - See Blades, Rotary-Wing		
Rotary-Wing Forward Blades, Rig - See Blades, Rotary-Wing, Forward		
Rotary-Wing Head and Controls	5-1	5-2
Inspect	5-6	5-31
Inspect after Extreme Blade Flapping (Sailing)	5-63.3	5-282
Install	5-9	5-55
Oil Tanks for Allowable Oil Leakage	5-6.1	5-36
Place in Service	5-4	5-21
Prepare for Shipment or Storage	5-2	5-8
Pressure Test Seals and Packings	5-5	5-26
Remove	5-8	5-44
Remove from Shipping Container	5-3	5-15
Repair	5-7	5-39
Retaining Nut Torque Check	5-9.1	5-68
Servicing - See Servicing, Oil		
Rotor Hub Oil Tank - See Oil Tank, Rotor Hub		
Rotor Hub Spline Inspection	5-21.3	5-109
Rotor RPM, Adjust Minimum (Without 74)	4-129	4-433
Rotor Shaft Aft - See Drive Shaft, Rotary-Wing		

	Task	Page
Rotor Tachometer Capacitor		
Install (AVIM)	8-93.3	8-299
Remove (AVIM)	8-93.2	8-298
Rotor Tachometer Indicator		
Install	8-89	8-283
Remove	8-88	8-281
RPM Limiting Stop, Power Turbine		
Replace (Without 74)	4-137	4-449
Rubber Seal Repair	2-367	2-1256
Rust Stripper Solution, Prepare (AVIM)	2-342	2-1189
S		
Safety Belt, Pilot or Copilot		
Install	2-127	2-437
Remove	2-126	2-436
Safety Blocks, Servocylinder - See Blocks, Safety, Servocylinder		
Salt Corroded Parts, Clean and Treat	2-344	2-1191
Screens		
Engine Air Inlet - See Engine Air Inlet Screens		
Generator Oil Outlet - See Main AC Generator Oil Outlet Screens		
Transmission, Aft - See Transmission Components, Aft		
Transmission, Combining, - See Transmission Components, Forward		
Screws, Bolt Replacement or Substitution for - See Bolts, Substitute or Replacement for Screws		
Seal, Engine Output Shaft		
Replace	4-23	4-145
Seal, Repair Rubber - See Rubber Seal Repair		
Seal Replacement, Cabin Windows 114S2721-5	2-165.2	2-529
Seal Replacement, Cabin Windows 173S2904-3 and 1560-CH47-944	2-165.3	2-532
Seal Replacement, Cargo Ramp	2-272.1	2-935
Seal Replacement, Cargo Ramp (Fuselage)	2-255.1	2-895
Seal Replacement, Transformer-Rectifier	9-2.1	9-20
Sealing, Fuselage	2-324	2-1129
Seals, Oil, Horizontal Hinge Pin		
Install	5-43	5-184
Remove	5-42	5-183
Seals, Oil, Pitch Varying Housing		
Install	5-25	5-134
Remove	5-24	5-129
Inspect Seal Surfaces	5-24.1	5-132
Seals, Oil, Vertical Hinge Pin		
Install Inner	5-35	5-160

Install Outer	5-34	5-157
Remove Inner	5-33	5-155
Remove Outer	5-32	5-154
Searchlight - See Landing Light		
Seat Armor - See Armor, Seat, Pilot or Copilot		
Seat Cushion, Pilot or Copilot		
Install	2-129	2-440
Remove	2-128	2-438
Seat, Pilot or Copilot		
Adjust	2-115	2-413
Clean	2-110	2-406
Install	2-114	2-411
Remove	2-111	2-407
Test	2-109	2-403
Seat Rails, Pilot or Copilot		
Install	2-113	2-410
Remove	2-112	2-409
Seat, Troop Commander's - See Troop Commander's Seat		
Seat, Troop, One-Man - See Troop Seat, One-Man		
Seat, Troop, Three-Man - See Troop Seat, Three-Man		
Seats, Troop - See Troop Seats		
Second Stage Mixing Assembly		
Check - Looseness	11-5.1	11-16
Clean - See Clean Flight Control System		
Inspect - Bearings (Installed)	11-9	11-42
Inspect - Bearings (Removed)	11-8	11-40
Inspect - General	11-7	11-36
Install	11-191	11-771
Remove	11-190	11-763
Repair	11-14	11-53
Rig	11-51	11-216
Second Stage Rig Pin Damage	11-20	11-79
Selector, Cabin Temperature		
Install	13-47	13-148
Remove	13-46	13-146
Selector Switch, Transmission Oil Pressure		
Install	8-87	8-278
Remove	8-86	8-276
Test (AVIM)	8-58	8-166

	Task	Page
Selector Switch, Transmission Oil Temperature		
Install	8-87	8-278
Remove	8-86	8-276
Test (AVIM)	8-73	8-196
Self Feedback Transducer, Extensible Link - See Extensible Link Self Feedback Transducer		
Self-Retaining Bolts	1-14	1-17
Sensing Element, Fire Detection - See Element, Sensing Fire Detection		
Sensor, Low Fuel Level - See Low Fuel Level Sensor		
Sequencer, Countermeasures Dispenser System - See Countermeasures		
Dispenser System Sequencer		
Serviceability Check		
Aft Transmission	6-140	6-505
Combining Transmission	6-170	6-569
Engine Transmission	6-198	6-649
Forward Transmission	6-112	6-433
Servicing - Air		
Accumulator, APU Start	1-64	1-245
Accumulator, APU Start Module	1-65	1-249
Accumulator, Flight Control (Power Control Module)	1-63	1-242
Accumulator, Power Steering/Swivel Lock	1-66	1-252
Accumulator, Pressurization, Utility System Reservoir	1-68	1-258
Accumulator, Wheel Brake	1-67	1-256
Cargo Hook	1-74	1-278
Landing Gear Shock Strut, Aft	1-72	1-272
Landing Gear Shock Strut, Forward	1-71	1-268
Tires	1-73	1-276
Servicing Check Valve, Main Fuel Tank		
Install No. 1 (Without 82)	10-90	10-432
Install No. 1 (With 82)	10-90.1	10-435
Install No. 2	10-92	10-441
Remove No. 1 (Without 82)	10-89	10-426
Remove No. 1 (With 82)	10-89.1	10-429
Remove No. 2	10-91	10-438
Servicing, Fuel (Gravity)	1-51.1	1-201
Servicing, Fuel (Pressure)	1-51	1-192
Servicing, General information	1-50	1-188
Servicing, Hoist Cable Cutter	1-75	1-280
Servicing, Hydraulic Fluid		
Flight Control Hydraulic System - Manual	1-62	1-240
Flight Control Hydraulic System, No. 1 - Power	1-60	1-232
Flight Control Hydraulic System, No. 2 - Power	1-61	1-236
Landing Gear Shock Strut, Aft	1-70	1-265
Landing Gear Shock Strut, Forward	1-69	1-261

	Task	Page
Shock Absorber, Rotary-Wing	1-58	1-224
Utility Hydraulic System Reservoir - Manual	1-62	1-240
Utility Hydraulic System Reservoir - Power	1-59	1-227
Servicing, Oil		
APU	1-53	1-207
Engine	1-52	1-203
Pitch-Bearing, Rotary-Wing Blade	1-56	1-218
Rotary-Wing Hub	1-55	1-214
Transmissions	1-54	1-208
Vertical Hinge Pin, Rotary-Wing Blade	1-57	1-221
Servocylinder Connecting Link, Forward or Aft		
Check - Control Clearance	11-5	11-12
Control Valve for Friction	11-6	11-18
Clean - See Clean Flight Control System		
Inspect - Bearings (Installed)	11-9	11-42
Inspect - Bearings (Removed)	11-8	11-40
Inspect - See Flight Control System		
Install	11-193	11-789
Remove	11-192	11-788
Repair - See Connecting Link, Repair		
Servocylinder Control Valve Boots		
Install	11-197	11-797
Remove	11-196	11-796
Servocylinder Safety Blocks - See Blocks, Safety, Servocylinder		
Servocylinders, Pivoting and Swiveling - See Pivoting and Swiveling Servocylinders		
Servo or Trim Motor, (CCDA) - See Motor, Trim or Servo		
Servo Valve, Extensible Link - See Extensible Link Servo Valve		
Shackle, Towing - See Towing Shackle, Forward Landing Gear, or Towing Shackle, Aft		
Landing Gear		
Shaft, Drive, Windshield Wiper		
Install	12-47	12-106
Remove	12-46	12-105
Shaft, Pitch Varying - See Pitch Varying Shaft		
Shaft Rotation LCT Actuator - See Actuator LCT Shaft Rotation		
Shaft Seal, Engine Output		
Replace	4-23	4-145
Shipment, Preparation for	1-4	1-1
Shock Absorber Bracket, Kevlar		
Bushing Replacement	5-81.1	5-458

	Task	Page
Windings Repair	5-81.2	5-466
Shock Absorber, Rotary-Wing Blade		
Adjust Length	5-90	5-544
Inspect (Teflon Bearings)	5-87.1	5-525
Inspect (Elastomeric Bearings)	5-87.2	5-528
Install	5-93	5-557
Place in Service	5-92	5-553
Prepare for Storage or Shipment	5-91	5-550
Remove	5-87	5-522
Service	1-58	1-224
Shock Absorber Components, Rotary-Wing Blade		
Bearing and Bushing, Inboard		
Install (AVIM) (Without 45)	5-89.3	5-542
Remove (AVIM) (Without 45)	5-89.2	5-541
Bearing, Rod End		
Install (Without 45)	5-88.2	5-535
Remove (Without 45)	5-88.1	5-534
Piston Cleaning	5-85	5-519
Rod End		
Install	5-89	5-537
Remove	5-88	5-532
Vent Valve		
Clean Vent Valve Filter	5-86	5-520
Shock Strut, Aft Landing Gear		
Convert, Left and Right	3-29	3-74
Inspect	3-39	3-97
Install	3-42	3-110
Remove	3-40	3-98
Repair (AVIM)	3-41	3-101
Service (Air)	1-72	1-272
Service (Fluid)	1-70	1-265
Shoulder Harness, Pilot or Copilot		
Inspect	2-117.1	2-419
Shutoff Manual Valve, APU Fuel		
Install	10-102	10-466
Remove	10-101	10-465

	Task	Page
Shutoff Valve, Engine Fuel		
Install	10-112	10-484
Remove	10-111	10-482
Shutoff Valve, Fuel Level		
Aft Tank		
Install	10-82	10-386
Remove	10-81	10-381
Forward Tank		
Install	10-72	10-350
Remove	10-71	10-347
Install No. 1 System (Without 82)	10-56	10-281
Install No. 1 System (With 82)	10-56.1	10-286
Install No. 2 System	10-58	10-294
Remove No. 1 System (Without 82)	10-55	10-269
Remove No. 1 System (With 82)	10-55.1	10-273
Remove No. 2 System	10-57	10-291
Side Position Light		
Install	9-67	9-228
Lamp		
Replace	9-68	9-231
Remove	9-66	9-227
Sideslip Sense Ports		
Install	8-32	8-109
Remove	8-31	8-107
Sideslip Sensing and Pitot Static System		
Drain	8-25	8-81
Inspect	8-24	8-80
Purge	8-26	8-83
Sight Indicator, Hub Oil Tank		
Install	5-11	5-77
Remove	5-10	5-74
Sight Indicator, Pitch Housing Oil Tank		
Install	5-13	5-81
Remove	5-12	5-78
Sight Indicator, Vertical Hinge Pin Oil Tank		
Install	5-13.2	5-84
Remove	5-13.1	5-82
Signal Processor/Power Supply, Torque, Engine (With 74)		
Install	8-22.2	8-70

	Task	Page
Remove	8-22.1	8-69
Single Point Refueling	1-51	1-192
Ski Provisions		
Skis (General)	16-84	16-306
Ski Installation	16-86	16-316
Ski Removal	16-85	16-308
Skin, Fuselage (General Information)		
Damage Requiring Replacement (AVIM)	2-14	2-53
Minor Damage	2-12	2-40
Reparable Damage (AVIM)	2-13	2-43
Skin and Web Repair	2-361	2-1247
Skin Inspection, Oilcan	2-359	2-1245
Skin Repair, Fuselage Coin Patch	2-362	2-1248
Skin Repair, Fuselage Oilcan	2-360	2-1246
Skin Repair, Fuselage Temporary Patch	2-364	2-1251
Skin Repair, Rotary-Wing Blade - See Blades, Rotary-Wing		
Slider Shaft, Aft		
Install	6-55	6-217
Remove	6-52	6-204
Slider Shaft, Forward		
Install	6-41	6-136
Remove	6-38	6-128
Sliding Window, Jettisonable Door - See Jettisonable Door Sliding Window		
Snubber Inspection, Combining Transmission Oil		
Cooler Fan Drive Shaft	6-185	6-605
Solenoid Valve, APU Fuel		
Install	10-100	10-463
Remove	10-99	10-461
Solenoid Valve, Heater Fuel		
Install	13-49	13-152
Remove	13-48	13-150
Solenoid Valve, Lower Controls Module - See Lower Controls Module Solenoid Valve		
Spar Repair, Rotary-Wing Blade		
Major Damage	5-67.1	5-332
Minor Damage	5-67	5-329
Spline Inspection, Rotor Hub	5-21.3	5-109
Spring Assembly Pitch - See Pitch Spring Assembly		
Spring Assembly Roll - See Roll Spring Assembly		
Spring Assembly Yaw - See Yaw Spring Assembly		

Spring Pitch Balance - See Pitch Balance Spring		
Spring Roll Balance - See Roll Balance Spring		
Spring Thrust Balance - See Thrust Balance Spring		
Spring Yaw Balance - See Yaw Balance Spring		
Squat Switch, Landing Gear - See Proximity Switch		
Stanchion, Litter		
Install	16-62	16-256
Remove	16-61	16-254
Standard Bushings, Use Of - See Bushings, Standard Use Of		
Standard Torque Limits	1-13	1-12
Standards, Bolt Hole - See Bolt Hole Standards		
Start Accumulator, APU		
Install	7-149	7-664
Remove	7-148	7-657
START Panel, Engine		
Install (With 74)	4-151	4-494
Remove (With 74)	4-150	4-493
Install (With 17)	9-98.2	9-329
Install (Without 17 or 74)	9-100	9-388
Remove (With 17)	9-98.1	9-314
Remove (Without 17 or 74)	9-99	9-353
Start Valve, APU Start Module		
Install	7-180	7-744
Remove	7-179	7-742
Start Valves, Engine		
Install	7-155	7-678
Remove	7-154	7-676
Starter Drive Housing		
Install	4-26	4-148
Remove	4-25	4-147
Starter Drive Shaft Seal		
Replace	4-24	4-146
Starter, Engine		
Install	7-142	7-639
Remove	7-141	7-636
Static and Sideslip Sensing System, Pitot - See Pitot Static and Sideslip Sensing System		
Static Ground Wire, Aft Landing Gear		
Inspect	3-36	3-90
Install	3-38	3-92

	Task	Page
Remove	3-37	3-91
Static Lock Mechanism, Aft Landing Gear		
Install	3-53	3-135
Remove	3-52	3-134
Static Port Adapter		
Install	8-34	8-113
Remove	8-33	8-111
Status Panel, Flare Dispenser		
Assemble	16-53	16-236
Disassemble	16-52	16-235
Install	16-54	16-237
Remove	16-51	16-234
Steering Lever, Aft Landing Gear		
Install	3-70	3-185
Remove	3-69	3-183
Steering Out of Phase Switch - See Power Steering Out of Phase Switch		
Steering Power (Discription)	7-290	7-1077
Steering Power Assy - See Power Steering Assy		
Steering Power Assy Pressure Tube - See Power Steering Assy Pressure Tube		
Steering Servo Valve - See Power Steering Servo Valve		
Steering/Swivel Lock Check Valve - See Power Steering/Swivel Lock Check Valve		
Steering/Swivel Lock Control Valves - See Power Steering/Swivel Lock Control Valve		
Steering/Swivel Lock Module Accumulator - See Power Steering/Swivel Lock Module Accumulator		
Steer/Swivel Lock Power Module - See Power Steer/Swivel Lock Module		
Step, Foldout - See Foldout Step		
Stick Control Pitch and Roll (Copilot's) - See Control Stick Pitch and Roll (Copilot's)		
Stick Control Pitch and Roll (Pilot's) - See Control Stick Pitch and Roll (Pilot's)		
Stick Position Indicator - See Cockpit Control Stick Position Indicator		
Stiffeners, Repair (General)	2-28	2-175
Major Damage (AVIM)	2-30	2-186
Minor Damage	2-29	2-183
Stop Pitch Overtravel - See Pitch Overtravel Stop		
Stop, Power Turbine RPM Limiting		
Replace (Without 74)	4-137	4-449
Stops Cumulative - See Cumulative Stops		
Storage		
General Information	1-93	1-358
General Inspection	1-95	1-360
General Procedures	1-94	1-359

	Task	Page
Preparation	1-4	1-1
Storage, Flyable		
Inspection, During Flyable Storage	1-98	1-366
Inspection, Before Flyable Storage	1-96	1-362
Inspection, After Servicing	1-100	1-369
Preparation (General)	1-97	1-363
Servicing, After Storage	1-99	1-367
Storage Intermediate		
Inspection, Before Storage	1-105	1-381
Inspection, After Servicing	1-107	1-386
Preparation	1-106	1-382
Servicing, After Storage	1-108	1-390
Storage, Short Term		
Inspection, Before Storage	1-101	1-370
Inspection, After Servicing	1-104	1-380
Preparation	1-102	1-371
Servicing, After Storage	1-103	1-377
Stowage Container, Cargo Handling		
Install	14-20	14-56
Remove	14-19	14-55
Strainer Element, Oil Filler, Powerplant		
Replace	4-97	4-360
Strakes		
Repair	2-216	2-777
Strap, Inertia Reel, Pilot or Copilot Shoulder Harness - See Inertia Reel, Pilot or Copilot Shoulder Harness, Strap		
Strap, Litter Support		
Install	16-66	16-261
Remove	16-65	16-260
Stringers (General Information)	2-16	2-56
Minor Damage (General)	2-15	2-54
Reparable Damage (AVIM)	2-17	2-74
Stripper Solution, Rust, Prepare (AVIM) - See Rust Stripper Solution, Prepare (AVIM)		
Strip, Rubber, Windshield Support Structure, Replace - See Windshield Support Structure Rubber Strip, Replace		
Strobex/Vibrex		
Structural Manifold, Lower Controls Actuator - See Lower Controls Actuator Structural Manifold		
Structure, Support, Cabin Equipment - See Cabin Equipment Support Structure		
Structure, Support, Cockpit Equipment - See Equipment Support Structure, Cockpit		
Stud, Locked-In, Replacement (AVIM)	1-15	1-21

	Task	Page
Substitute AN Bolts For AN Rivets - See Bolts, AN Substitute for AN Rivets		
Substitution Authority	1-7	1-2
Substitution of Bolts - See Bolts, Substitution Of		
Suction Feed Check Valve		
Install	10-62	10-314
Remove	10-61	10-312
Sump, Aft Transmission		
Assemble	6-80	6-306
Disassemble	6-79	6-304
Install	6-81	6-309
Remove	6-78	6-302
Sump, Combining Transmission		
Assemble	6-191	6-631
Disassemble	6-190	6-629
Install	6-192	6-634
Remove	6-189	6-625
Sump, Forward Transmission		
Assemble	6-36	6-116
Disassemble	6-34	6-110
Install	6-37	6-120
Remove	6-33	6-108
Repair	6-35	6-112
Support Beam and Bearings, Center Cargo Hook		
Inspect	16-9.1	16-92
Install	16-10	16-93
Remove	16-9	16-90
Support Beam Bushings, Center Cargo Hook		
Inspect	16-8.1.1	16-85
Install	16-8.3	16-87
Remove	16-8.2	16-86
Support Bellcrank Pitch and Roll, Control Pallet STA 120.00 - See Control Pallet STA 120.00 Pitch and Roll Idler Bellcrank Support		
Support Bellcrank Yaw and Thrust Control Pallet STA 95.00 - See Control Pallet STA 95.00 Yaw and Thrust Idler Bellcrank Support		
Support Bracket, Actuator		
Install (Without 74)	4-111	4-396
Remove (Without 74)	4-110	4-395
Support Brackets, Suppressive Fire System		
Install	2-212	2-764
Remove	2-211	2-761

	Task	Page
Support, Fittings Inspection, Combining Transmission	2-274.1	2-940
Support, Pitot Tube		
Install	8-29	8-103
Remove	8-28	8-101
Support Plates, Suppressive Fire System		
Install Aft	2-259	2-905
Install Forward	2-235	2-810
Remove Aft	2-258	2-904
Remove Forward	2-234	2-808
Support Structure, Bushings, Forward Transmission		
Install	2-73.2	2-308
Remove	2-73.1	2-305
Support Structure, Equipment, Aft Pylon - See Equipment Support Structure, Aft Pylon		
Support Strut, Engine Cover		
Install	4-49.2	4-249
Remove	4-49.1	4-248
Support Thrust Detent - See Thrust Detent Support		
Supports, APU - See APU Supports		
Swashplates		
Ball and Slider Travel, Check	11-41	11-157
Ball Spherical Bearing		
Axial Play Check (Installed)	5-114.1	5-649
Axial Play Check (Removed)	5-121	5-671
Friction Check	5-114	5-641
Inspect and Repair	5-123.1	5-678
Install	5-125	5-687
Remove	5-122	5-672
Bearing Friction Check	5-115	5-653
Clean (Installed)	5-113	5-640
Clean (Removed)	5-118	5-666.5
Disassemble and Inspect Fwd and Aft Swashplate Assembly Bearings	5-117.1	5-666
Install (Aft)	5-133	5-730
Install (Forward)	5-132	5-726
Place In Service	5-131	5-723
Prepare for Storage and Shipment	5-130	5-715
Remove (Aft)	5-117	5-662
Remove (Forward)	5-116	5-658
Rig	11-54	11-240
Rotating Ring		

	Task	Page
Inspect	5-119	5-667
Repair (AVIM)	5-120	5-669
Seal Replacement, Lower (AVIM)	5-126.1	5-698
Sliding Sleeve Bearings		
Inspect	5-119.1	5-668
Install (AVIM)	5-124	5-682
Remove (AVIM)	5-123	5-676
Stationary Ring, Aft		
Inspect	5-128	5-712
Repair (AVIM)	5-129	5-713
Stationary Ring, Fwd		
Inspect	5-126	5-697
Repair (AVIM)	5-127	5-710
Switch, Agent, Fire Extinguisher		
Install	12-20	12-54
Remove	12-19	12-52
Switch, Air Pressure, Heater		
Install	13-53	13-159
Remove	13-52	13-158
Switch and Adapter, Fire Pull Control		
Install	12-17	12-48
Remove	12-16	12-47
Switches, Forward and Aft Cargo Adjust (AVIM)	16-28	16-153
Switches, Heater Thermostatic		
Install	13-51	13-156
Remove	13-50	13-154
Switch Box, Fuel Quantity - See Fuel Quantity Switch Box		
Switch, Inertia, Emergency Light		
Install	17-12	17-28
Remove	17-11	17-27
Switch, Out-of-Phase Power Steering - See Power Steering Out-of-Phase Switch		
Switch Panel, Caution Lights - See Caution Lights Switch Panel		
Switch, Proximity, Aft Landing Gear - See Proximity Switch, Aft Landing Gear		
Switch, Safety, Countermeasures Dispenser System - See Countermeasures Dispenser System Safety Switch		
Switch, Temperature, Utility Reservoir/Cooler		
Install	7-211	7-805
Remove	7-210	7-803
Switched Battery Bus Relay		
Install	9-19	9-59
Remove	9-18	9-58

	Task	Page
Switches, Emergency Power (Without 74)		
Install	8-7	8-26
Remove	8-6	8-25
Switches, Transmission, Oil Pressure		
Aft Transmission		
Auxiliary	8-71	8-192
Main	8-70	8-190
Combining Transmission		
Auxiliary	8-67	8-184
Main	8-66	8-182
Engine Transmission		
No. 1	8-68	8-186
No. 2	8-69	8-188
Forward Transmission		
Replace	8-65	8-180
Rotor Shaft, Aft	8-72	8-194
Test	8-58	8-166
Switches, Forward and Aft Cargo Adjust (AVIM)	16-28	16-153
Switches, Heater Thermostatic		
Install	13-51	13-156
Remove	13-50	13-154
Switches, Winch Limit		
Adjust	14-3	14-10
Swivel Housing and Spindle, Aft Landing Gear		
Assemble (AVIM)	3-63	3-162
Disassemble (AVIM)	3-62	3-159
Install	3-66	3-176
Remove	3-61	3-155
Test (AVIM)	3-64	3-167
Seals		
Install	3-58	3-150
Remove	3-57	3-148
Data Plate (AVIM)	3-65	3-174
Swivel Lock Actuator Cylinder		
Assemble (AVIM)	7-312	7-1122
Clean-Parts (AVIM)	7-310	7-1118
Disassemble (AVIM)	7-309	7-1116
Inspect (AVIM)	7-311	7-1120
Install	7-314	7-1127
Remove	7-308	7-1114

	Task	Page
Test (AVIM)	7-313	7-1124
Swivel Lock, Aft Landing Gear		
Install	3-68	3-181
Remove	3-67	3-180
Swiveling and Pivoting Servocylinders - See Pivoting and Swiveling Servocylinders		
Symbols, Change	1-9	1-2
Synchronizing Shafting - See Drive Shafting		
T		
Tab, Trim, Rotary-Wing Blades - See Rotary-Wing Blades Trim Tab		
Tachometer, Gas Producer - See Gas Producer Tachometer		
Tachometer Generator, No. 1 Gas Producer (Without 74)		
Install	8-12	8-37
Remove	8-9	8-30
Test	8-11	8-34
Tachometer Generator, No. 2 Gas Producer (Without 74)		
Install	8-13	8-39
Remove	8-10	8-32
Test	8-11	8-34
Tachometer Indicator, Rotor		
Install	8-89	8-283
Remove	8-88	8-281
Tail Position Light		
Install	9-64	9-224
Lamp		
Replace	9-65	9-226
Remove	9-63	9-222
Tailcone, Airframe		
Repair	2-275	2-943
Repair (AVIM)	2-276	2-950
Tandem Cargo Hook - See Cargo Hook, Fwd and Aft		
Tank, Fuel - See Aft, Forward, or Main Fuel Tank		
Tank Unit, Fuel Quantity Indicating		
Install	8-82	8-261
Remove	8-81	8-259
Tape, Anti-Chafing, Application of - See Application of Anti-Chafing Tape		
Tape, Velcro, Application of - See Velcro Tape, Application of		
TEAC (Turbine Engine Analysis Check) (Without 74)	4-3	4-25
Temperature Bulb, Flight Control Reservoir/Cooler - See Flight Control Reservoir/Cooler Temperature Bulb		

	Task	Page
Temperature Controller		
Install	13-59	13-169
Remove	13-58	13-168
Temperature Switch, Flight Control Reservoir/Cooler - See Flight Control Reservoir/Cooler Temperature Switch		
Terminal Board Module		
Install	9-166	9-670
Remove	9-165	9-668
Test AFCS Interface - See AFCS Interface Test		
Test Box, Dynamic Absorber - See Absorber, Dynamic, Test Box		
Test Equipment - See Special Tools and Test Equipment		
Test Switch, Power Assurance Panel and, (With 74)		
Install	4-157	4-513
Remove	4-156	4-512
Test Tank After Installation		
Aft Tank	10-32	10-150
Forward Tank	10-27	10-124
Main Tank	10-22	10-89
Thermometer - See Fat Gauge		
Thermostat, Cabin		
Install	13-61	13-172
Remove	13-60	13-171
Thermostatic Switches, Heater		
Install	13-51	13-156
Remove	13-50	13-154
Three-Way Valve, Power Control Module - See Power Control Module Three-Way Valve		
Three-Way Valve, Power Transfer Unit Module - See Power Transfer Unit Module Three-Way Valve		
Three-Way Valves, Pressure Control Module		
Install	7-163	7-693
Remove	7-162	7-691
Thrust and Yaw Pallet Idler Bellcranks Rigging		
Thrust Viscous Damper Arm - See Yaw, Thrust, Roll or Pitch Viscous Damper Arms		
Thrust Balance Spring		
Adjust	11-133	11-591
Install	11-132	11-590
Remove	11-131	11-589
Thrust Balance Spring Bracket		

	Task	Page
Install	11-131.2	11-589
Remove	11-131.1	11-588
Thrust CCDA Actuator		
Assemble (AVIM)	11-157	11-640
Disassemble (AVIM)	11-155	11-636
Install	11-158	11-646
Remove	11-154	11-634
Test-Bench (AVIM)	11-279	11-1156
Thrust Control		
Assemble (AVIM) Pilot or Copilot	11-65	11-291
Clean (Installed) Pilot or Copilot	11-59	11-276
Clean (Removed) (AVIM) Pilot or Copilot	11-64	11-290
Disassemble (AVIM) Pilot or Copilot	11-63	11-285
Inspect Pilot or Copilot	11-60	11-278
Install (Copilot)	11-67	11-304
Paint Pilot or Copilot	11-68	11-310
Remove (Copilot)	11-62	11-282
Rig Pilot or Copilot	11-43	11-177
Install (Pilots)	11-66	11-298
Remove (Pilots)	11-61	11-279
Rig	11-43	11-177
Thrust Control Detent		
Adjust	11-109	11-535
Install	11-108	11-534
Remove	11-107	11-533
Thrust Control Grip		
Assemble (With 60)	9-140.3	9-556
Assemble (Without 60)	9-140	9-549
Disassemble (With 60)	9-140.2	9-554
Disassemble (Without 60)	9-139	9-547

	Task	Page
Install	9-141	9-567
Remove	9-138	9-546
Test (With 60) and 74)	9-140.6	9-564
Test (With 60 and Without 74)	9-140.4	9-558
Test (Without 60 and With 74)	9-140.5	9-561
Test (Without 60 and 74)	9-140.1	9-551
Thrust Control Detent Adjustment	11-109	11-535
Thrust Control Rigging Pilot's or Copilot's	11-43	11-177
Thrust Control Rig Pin Damage	11-17	11-68
Thrust Control Travel Check	11-39	11-149
Thrust Detent Support		
Install	11-111	11-539
Remove	11-110	11-537
Thrust Idler Bellcrank Control Pallet STA 95.00 - See Control Pallet STA 95.00 Thrust Idler Bellcrank		
Thrust, Yaw, Intermediate Bellcranks		
Clean - See Clean Flight Control System		
Inspect - Corrosion - See Corrosion Bellcranks Inspect		
Inspect - General - See Bellcranks and Idler Arms, Inspect		
Install - See Yaw or Thrust Intermediate Bellcranks		
Remove - See Yaw or Thrust Intermediate Bellcranks		
Repair - General - See Control Arms and Bellcranks, Repair		
Repair - Finish - See Finish Bellcrank and Arms		
Thrust, Roll or Yaw ILCA Input Connecting Links Rigged - See Rig Roll, Yaw or Thrust ILCA Input Connecting Links		
Thrust or Pitch Viscous Damper Connecting Link		
Install	11-126	11-578
Remove	11-125	11-577
Tiedown Adapter, 5,000 Pound, Cabin Floor		
Install	2-206	2-739
Remove	2-205	2-736
Tiedown Adapters, Ramp		
Install	2-246	2-837
Remove	2-245	2-836
Tiedown Assembly, 10,000 Pound Cabin Floor (With 19)		
Install	2-237.2	2-817
Remove	2-237.1	2-815
Tiedown Fitting, 10,000 Pound Cabin Floor (Without 19)		
Install	2-237	2-813
Remove	2-236	2-812

	Task	Page
Tiedown Kit		
Install	1-33	1-116
Remove	1-34	1-119
Tiedown Receiver, Rotary-Wing Blade - See Rotary-Wing Blade Tiedown Receiver		
Tie Bar Assembly, Rotor Head		
Inspect	5-23.1.1	5-123
Install	5-23.2	5-125
Remove	5-23.1	5-118
Timer, Flare Dispenser		
Install	16-57	16-247
Remove	16-56	16-246
Tire and Wheel, Landing Gear		
Install	3-7.1	3-25
Remove	3-7	3-22
Tire and Tube, Landing Gear		
Install	3-11	3-34
Remove	3-8	3-28
Tool Lead/Lag - See Lead/Lag Tool		
Tools and Test Equipment		
	1-17	1-32
Tools Rigging Cockpit		
Install	11-22	11-82
Remove	11-23	11-85
Torque Arm, Fwd Landing Gear		
Install	3-18	3-57
Remove	3-17	3-55
Torque Check, Pitch Link Bolt		
	5-99.1	5-603
Torque Check, Rotary-Wing Head Retaining Nut		
	5-9.1	5-68
Torque Limits		
	1-13	1-12
Torquemeter Indicator, Dual Engine		
Adjust (Without 74)	8-18.1	8-57
Install	8-89	8-283
Remove	8-88	8-281
Test (AVIM) (Without 74)	8-19	8-61
Torquemeter Power Supply, Engine (Without 74)		
Install	8-22	8-67
Remove	8-20	8-64
Test (AVIM)	8-21	8-65
Torque Signal Processor/Power Supply, Engine (With 74)		
Install	8-22.2	8-70
Remove	8-22.1	8-69
Towing		

	Task	Page
Alternate	1-20	1-65
Normal	1-19	1-60
Towing Shackle, Aft Landing Gear		
Install	3-60	3-154
Remove	3-59	3-153
Towing Shackle, Forward Landing Gear		
Install	3-26	3-66
Remove	3-25	3-65
Tracking and Balancing, Rotary-Wing Blades Rotary-Wing Blades Refer to TM 1-6625-724-13&P, Aviation Vibration Analyzer		
Tracking, Rotary-Wing Blades - See Tracking and Balancing, Rotary-Wing Blades Refer to TM 1-6625-724-13&P, Aviation Vibration Analyzer		
Trailing Edge Fairing		
Install	2-288	2-971
Remove	2-286	2-969
Repair	2-287	2-970
Transducer, Air Data		
Install	16-93	16-341
Remove	16-92	16-340
Transducer, Assembly, Thrust Control Position (With 74)		
Install and Rig	4-153	4-498
Remove	4-152	4-495
Transducer Linear End Fitting Bearing		
Install (AVIM)	11-175	11-695
Remove (AVIM)	11-174	11-694
Transducer Linear Rod End Bearing		
Install (AVIM)	11-173	11-692
Remove (AVIM)	11-172	11-691
Transducer Pitch Control Position		
Adjust	11-177	11-703
Install	11-169	11-685
Remove	11-168	11-684
Transducer Roll or Yaw Control Position		
Adjust	11-176	11-697
Install - Yaw	11-167	11-682
Install - Roll	11-171	11-689
Remove - Yaw	11-166	11-681
Remove - Roll	11-170	11-688
Transducer, Transmission Oil Pressure		

	Task	Page
Aft Transmission		
Install	8-62	8-177
Remove	8-61	8-176
Combining, and Engine Transmissions		
Install	8-60	8-174
Remove	8-59	8-173
Forward Transmission		
Install	8-64	8-179
Remove	8-63	8-178
Transfer Bellcranks, Cockpit Control - See Cockpit Control Transfer Bellcranks		
Transfer Bellcranks in Cockpit Rigged - See Cockpit Control Transfer Connecting Links		
Transfer Connecting Links Cockpit Control - See Cockpit Control Transfer Connecting Links		
Transfer Cylinder - See Cylinder, Transfer-Utility Return Control Module		
Transfer Valve Brake - See Brake Transfer Valve		
Transformer, APU Generator Current, Aft - See APU Generator Current Transformer, Aft		
Transformer, APU Generator Current, Forward - See APU Components - Generator Current Transformer, Forward		
Transformer Fail Relay, DC Power		
Install	9-17	9-56
Remove	9-16	9-54
Transformer, Instrument - See Instrument Transformer		
Transformer, Lighting, 26V - See Lighting Transformer, 26V		
Transformer, Main Current - See Main Current Transformer		
Transformer Rectifiers		
Install	9-3	9-22
Remove	9-2	9-18
Replace Seal	9-2.1	9-20
Transformers, Nose Compartment		
Install	9-46.2	9-141
Remove	9-46.1	9-140
Transmission, Aft (General)		
Assemble (Build Up)	6-1	6-2
Disassemble (Tear Down)	6-96	6-362
Drain Oil	6-93	6-351
Drive Shaft Seal, Oil Cooler Fan		
Install	6-138	6-502
Remove	6-89	6-334
Remove	6-88	6-332
Flush Oil System	6-139	6-503
Generator Drive Shaft Seal		

	Task	Page
Install	6-87	6-329
Remove	6-86	6-327
Hydraulic Pump Drive Shaft Oil Seal		
Install	6-85	6-324
Remove	6-84	6-322
Input Shaft Oil Seal		
Install	6-83	6-319
Remove	6-82	6-317
Install	6-97	6-364
Leakage, Allowable	6-137	6-501
Oil Contamination Analysis	6-136	6-500
Oil Cooler - See Oil Cooler, Aft Transmission		
Oil Filter Element Replacement, Aux	6-154	6-539
Oil Filter Element Replacement, Main	6-148	6-525
Oil Pump, Aux		
Install	6-153	6-537
Remove	6-152	6-535
Oil Pump, Main		
Adjust	6-151	6-533
Install	6-150	6-532
Remove	6-149	6-531
Outside Surface		
Repair	6-93.1	6-352
Prepare for Storage or Shipment	6-94	6-355
Remove	6-92	6-341
Remove from Storage	6-95	6-359
Rotor Shaft Seal		
Install	6-91	6-338
Remove	6-90	6-337
Screen, Debris Detection		
Install	6-158	6-546
Remove	6-157	6-544
Screen, Main Inlet		
Inspect	6-131	6-490
Install	6-156	6-542
Remove	6-155	6-541
Serviceability Check	6-140	6-505
Servicing	1-54	1-208
Sight Gauge Replacement	6-159	6-552

	Task	Page
Sump - See Sump, Aft Transmission		
Transmission, Combining	6-1	6-2
Assemble	6-76	6-290
Chip Detector		
Remove, Install and Inspect Plug	6-178	6-584
Install	6-179	6-586
Remove	6-177	6-583
Disassemble	6-73	6-279
Drain Oil	6-168	6-565
Drive Shaft Seal, Oil Cooler Fan		
Install	6-71	6-264
Remove	6-70	6-262
Flush Oil System	6-169	6-567
Input Shaft Oil Seal		
Install	6-65	6-250
Remove	6-64	6-248
Install	6-77	6-293
Leakage, Allowable	6-167	6-564
Oil Contamination Analysis	6-166	6-563
Oil Cooler - See Oil Cooler Assembly Combining Transmission		
Oil Filter Element Replacement, Aux	6-173	6-578
Oil Filter Element Replacement, Main	6-171	6-571
Oil Pump Adjustment, Main	6-172	6-576
Output Shaft Oil Seal, Aft		
Install	6-69	6-259
Remove	6-68	6-257
Output Shaft Oil Seal, Forward		
Install	6-67	6-255
Remove	6-66	6-253
Outside Surface		
Repair	6-73.1	6-281
Prepare for Shipment or Storage	6-74	6-284
Remove	6-72	6-273
Remove from Storage	6-75	6-288
Screen, Debris Detection		
Inspect	6-175	6-581
Install	6-176	6-582
Remove	6-174	6-580
Screen, inlet		

	Task	Page
Install	6-181	6-589
Remove	6-180	6-588
Serviceability Check	6-170	6-569
Servicing	1-54	1-208
Sight Gauge Replacement	6-193	6-638
Sump - See Sump Combining Transmission		
Transmission, Engine (General)	6-1	6-2
Assemble (Left) (Build Up)	6-105	6-418
Assemble (Right) (Build Up)	6-106	6-420
Chip Detector Plug		
Remove, Install and Inspect	6-205	6-667
Install	6-206	6-669
Disassemble (Tear Down)	6-102	6-406
Drain Oil	6-196	6-643
Flush Oil System	6-197	6-646
Install	6-107	6-423
Leakage, Allowable	6-195	6-642
Oil Contamination Analysis	6-194	6-641
Oil Cooler - See Oil Cooler, Engine Transmission		
Oil Filter Element Replacement	6-199	6-654
Oil Pump Adjustment	6-200	6-660
Output Shaft Oil Seal		
Install	6-99	6-378
Remove	6-98	6-376
Outside Surface		
Repair	6-102.1	6-408
Prepare for Shipment or Storage	6-103	6-411
Quill Shaft Inspection	6-101	6-405
Remove	6-100	6-402
Remove from Storage	6-104	6-415
Screen, Debris Detection		
Inspect	6-202	6-664
Install	6-203	6-665
Remove	6-201	6-662
Screen Inlet		
Inspect	6-210	6-685
Install	6-211	6-686
Remove	6-209	6-684
Serviceability Check	6-198	6-649

	Task	Page
Servicing	1-54	1-208
Sight Gauge Replacement	6-212	6-688
Temperature and Chip Detector		
Install	6-208	6-675
Remove	6-207	6-670
Functional Test	6-207.1	6-671
Transition Duct, Heater		
Install	13-23	13-84
Remove	13-22	13-82
Transmission Fairing, Engine		
Install	4-73	4-308
Remove	4-70	4-303
Repair (General Information and Minor Damage)	4-71	4-306
Repair (Major Damage)	4-72	4-307
Transmission, Forward (General)	6-1	6-2
Air Inlet Duct		
Install	6-122	6-468
Remove	6-121	6-466
Assemble	6-50	6-180
Disassemble	6-47	6-164
Drain Oil	6-110	6-430
Flight Control Pump Shaft Oil Seal		
Install	6-45	6-146
Remove	6-44	6-144
Flush Oil System	6-111	6-431
Input Shaft Oil Seal		
Install	6-43	6-141
Remove	6-42	6-139
Install (Package)	6-51	6-190
Leakage, Allowable	6-109	6-429
Oil Contamination Analysis	6-108	6-428
Oil Cooler - See Oil Cooler, Forward Transmission		
Oil Filter Element Replacement, Aux	6-129	6-487
Oil Filter Element Replacement, Main	6-123	6-472
Oil Pump, Auxiliary		
Install	6-128	6-485
Remove	6-127	6-483
Oil Pump, Main		
Adjust	6-126	6-481
Install	6-125	6-479

	Task	Page
Remove	6-124	6-477
Prepare for Storage or Shipment	6-48	6-174
Remove	6-46	6-149
Remove from Storage	6-49	6-178
Repair Outside Surface	6-47.1	6-171
Rotor Shaft Oil Seal		
Install	6-40	6-135
Remove	6-39	6-134
Screen, Debris Detection		
Install	6-134	6-495
Remove	6-133	6-493
Screen, Inlet		
Inspect	6-131	6-490
Install	6-132	6-491
Remove	6-130	6-489
Serviceability Check	6-112	6-433
Servicing	1-54	1-208
Sight Gauge Replacement	6-135	6-497
Slider Shaft		
Install	6-41	6-136
Remove	6-38	6-128
Sump - See Sump, Forward Transmission		
■ Transmission Oil Pressure Indicator and Selector Switch		
Install	8-87	8-278
Remove	8-86	8-276
Test (AVIM)	8-58	8-166
Transmission Oil Pressure Switches - See Switches, Transmission Oil Pressure		
Transmission Oil Pressure Transducer - See Transducer, Transmission Oil Pressure		
■ Transmission Oil Temperature Indicator and Selector Switch		
Install	8-87	8-278
Remove	8-86	2-276
Test (AVIM)	8-58	8-166

	Task	Page
Transmission Oil Temperature Transmitter - See Transmitter, Oil Temperature		
Transmitter, Engine Oil Pressure (Without 44)		
Install	8-16	8-48
Remove	8-15	8-43
Transmitter, Engine Oil Pressure (With 44)		
Remove	8-15.1	8-44
Replace	8-15.2	8-46
Install	8-16.1	8-50
Transmitter, Engine Oil Temperature		
Replace	8-18	8-56
Transmitter, Fuel Flow		
Install	8-80.2	8-217
Remove	8-80.1	8-215
Transmitter, Pressure Control Module Pressure		
Install	7-169	7-709
Remove	7-168	7-707
Transmitter, Transmission Oil Temperature		
Aft		
Replace	8-78	8-211
Combining		
Replace	8-75	8-205
Engine, No. 1		
Replace	8-76	8-207
Engine, No. 2		
Replace	8-77	8-209
Forward		
Replace	8-74	8-203
Transparent Plastic Finish Restoration	2-345	2-1194
Travel Check, Roll and Yaw - See Cockpit Travel Quadrant, Pitch, Roll, or Yaw		
Travel Quadrant, Pitch, Roll or Yaw Cockpit - See Cockpit Travel Quadrant, Pitch, Roll, or Yaw		
Trim Indicator, Cyclic - See Cyclic Trim Indicator		
Trim or Servo Motor (CCDA) - See Motor Trim or Servo		
Trim Tab Repair, Rotary-Wing Blade - See Blades, Rotary-Wing		
Trolley Link Assemblies, Forward and Aft		
Install	2-262.2	2-913
Remove	2-262.1	2-911
Troop Commander Seat		
Assemble (ACA4300)	2-132	2-451
Assemble (A-6632)	2-132.1	2-455
Disassemble (ACA4300)	2-131	2-443
Disassemble (A-6632)	2-131.1	2-447
Install	2-133	2-461

	Task	Page
Position for Use (Unstow)	2-135	2-465
Remove	2-130	2-442
Stow	2-134	2-463
Troop Jump Signal Dimming Resistor (Without 17)		
Adjust	9-124	9-473
Install	9-123	9-467
Remove	9-122	9-465
Troop Seat, One-Man		
Assemble	2-226	2-795
Disassemble	2-225	2-793
Install	2-223	2-789
Remove	2-224	2-791
Stow	2-227	2-797
Unstow	2-222	2-787
Troop Seat, Three-Man		
Assemble	2-232	2-805
Disassemble	2-231	2-803
Install	2-229	2-799
Remove	2-230	2-801
Stow	2-233	2-807
Unstow	2-228	2-798
Troop Seats		
Clean	2-221	2-786
TROOP WARN/HTG Overhead Panel		
Install (With 17)	9-98.2	9-329
Install (Without 17 or 74)	9-100	9-388
Remove (With 17)	9-98.1	9-314
Remove (Without 17 or 74)	9-99	9-353
Troop Warning Box		
Assemble	9-120	9-456
Disassemble	9-119	9-451
Install	9-121	9-462
Remove	9-118	9-447
Tube Bending (AVIM)	7-4.2	7-22
Tube, Landing Gear Wheel - See Tire and Tube, Forward and Aft Landing Gear		
Tube, Pitot		
Install	8-30	8-105
Remove	8-27	8-100

	Task	Page
Tube Pressure, Power Steering Assembly - See Power Steering Assembly Pressure Tube		
Tubing Repair, Aluminum - See Aluminum Tubing Repair		
Tunnel Connecting Links - See Connecting Links Tunnel		
Tunnel Connecting Links - See Connecting Links, Tunnel		
Tunnel Control Arms		
Check Clearance - See Flight Controls Clearance Check		
Clean - See Clean Flight Control System		
Inspect - See Bellcranks and Idler Arms, Inspect		
Install	11-241	11-935
Remove	11-240	11-933
Repair - See Control Arms and Bellcranks, Repair		
Repair - Finish - See Finish Bellcranks and Arms		
Tunnel Control Idler		
Check Clearance - See Flight Control Clearance		
Clean - See Clean Flight Control System		
Inspect - See Bellcrank and Idler Arms, Inspect		
Install	11-243	11-943
Remove	11-242	11-941
Repair - See Control Arms and Bellcranks, Repair		
Repair Finish - See Finish Bellcranks and Arms		
Tunnel Controls Linkage Rigging	11-56	11-255
Tunnel Covers - See Access Doors, Cabin Crown		
Tunnel Drains		
Replace	2-213	2-769
Turbine Engine Analysis Check (TEAC) (Without 74)	4-3	4-25
Turn and Slip Indicator - See Indicator, Turn and Slip		

U

Upper Drag Link, Aft Landing Gear		
Install	3-51	3-132
Remove	3-49	3-126
Repair (AVIM)	3-50	3-128
Using the Manual		
		vii
Utility Accumulator		
Install	7-218.2	7-833
Remove	7-218.1	7-831
Utility Accumulator Relief Valve		
Install	7-218.4	7-837

	Task	Page
Remove	7-218.3	7-835
Utility and Flight Control Hydraulic Pump Test - See Flight Control and Utility Hydraulic Pump Test		
Utility Hydraulic Cooling Fan		
Install	7-223	7-841
Remove	7-219	7-839
Utility Hydraulic Pump		
Install	7-151	7-669
Remove	7-150	7-666
Test (AVIM)	7-26	7-164
Utility Hydraulic System		
Depressurize	7-135.1	7-622
Description, Theory of Operation	7-135	7-608
Flush Serious Contamination	7-16.1	7-106
Utility Light		
Install	9-112	9-436
Remove	9-111	9-432
Lamp and Lens Replacement	9-111.1	9-434
Utility Reservoir/Cooler - See Reservoir		
Cooler, Utility		
Utility Return Control Module - See Module, Utility Return Control		
V		
Valve Actuating Cargo Door - See Cargo Door Pressure Actuating Valve		
Valve, Air, Fwd Landing Gear - See Air Valve, Fwd Landing Gear		
Valve, APU Fuel Shutoff Manual		
Install	10-102	10-466
Remove	10-101	10-465
Valve, APU Fuel Solenoid		
Install	10-100	10-463
Remove	10-99	10-461
Valve Brake Transfer - See Brake Transfer Valve		
Valve, Butterfly, Air Outlet Flap		
Install	13-41	13-133
Remove	13-40	13-131
Valve Check Steering/Swivel Lock - See Power Steering/Swivel Lock Check Valve		
Valve Control Power Steering and Swivel Lock - See Power Steering and Swivel Lock Control Valve		

	Task	Page
Valve, Defrost		
Install	13-27	13-92
Remove	13-26	13-90
Valve, Engine Start		
Install	7-155	7-678
Remove	7-154	7-676
Valve, Fuel Crossfeed		
Install	10-114	10-489
Remove	10-113	10-486
Valve, Heater Fuel Solenoid		
Install	13-49	13-152
Remove	13-48	13-150
Valve Hoist Control - See Hoist Control Valve		
Valve Hoist, Pressure Reducing - See Hoist Pressure Reducing Valve		
Valve Hook Release - See Hook Release Valve		
Valve, Manual Refueling		
Install	10-110	10-479
Remove	10-109	10-477
Valve Parking Brake - See Brake Parking Valve		
Valve, Pilot, Utility Pressure Control Module		
Install	7-161	7-689
Remove	7-160	7-687
Valve, PTU, Pressure Control Module		
Install	7-171	7-713
Remove	7-170	7-711
Valve Ramp Control - See Ramp Control Valve		
Valve Reducing Brake Pressure - See Brake Pressure Reducing Valve		
Valve Reducing Hoist Pressure - See Hoist Pressure Reducing Valve		
Valve Relief Hoist Pressure - See Hoist Pressure Relief Valve		
Valve Servo Power Steering - See Power Steering Servo Valve		
Valve Sequence Cargo Door - See Cargo Door Sequence Valve		
Valve, Shutoff Engine Fuel		
Install	10-112	10-484
Remove	10-111	10-482

Valve Shutoff Hoist Control - See Hoist Control Shutoff Valve

Valve, Three-Way, Utility Pressure Control

Install 7-163 7-693

Remove 7-162 7-691

■ Velcro Tape, Application Of 2-338 2-1185

Vent Assy, Fuel Tank

Aft or Forward Tank

Install 10-66 10-326

Remove 10-65 10-321

Main Tank

Install 10-44 10-220

Remove 10-43 10-215

Vent Fairing, Fuel Tank

Install 10-64 10-319

Remove 10-63 10-317

Vent System Flow Test 10-118 10-504

Vent System Pressure Test 10-117 10-499

Vent Valve, Fuel Tank

Aft Tank

Install 10-84 10-395

Remove 10-83 10-392

Forward Tank

Install 10-74 10-360

Remove 10-73 10-358

Main Tank

Install 10-46 10-231

Remove 10-45 10-226

Vent Valve, Shock Absorber - See Shock Absorber, Rotary-Wing Blade

Vertical Hinge Pin Bearings - See Bearings, Vertical Hinge Pin

Vertical Hinge Pin Oil Manifold Tube - See Oil Manifold, Vertical Hinge Pin

Vertical Hinge Pin Oil Seals - See Oil Seal, Vertical Hinge Pin

Vertical Hinge Pin Oil Tanks - See Oil Tanks, Vertical Hinge Pin

Vertical Hinge Pin Oil Tank Sight Indicator - See Sight Indicator, Vertical Hinge Pin Oil Tank

Vibration Absorber - See Absorber, Dynamic

Vibration Analysis, Aft Transmission Fan - Refer To TM 1-6625-724-13&P

■ Vibration Correction Procedure (Aviation Vibration Analyzer)

Vibration Test, Powerplant (Without **74**) - Refer To TM 1-6625-724-13&P

	Task	Page
Viscous Damper, Pitch, Roll, Yaw or Thrust		
Assemble, Roll (AVIM)	11-118	11-558
Assemble, Thrust, Pitch or Yaw (AVIM)	11-117	11-555
Disassemble, Inspect and Repair Thrust, Pitch or Yaw (AVIM)	11-115	11-545
Disassemble, Inspect and Repair Roll (AVIM)	11-116	11-550
Adjust (1025-820) (AVIM)	11-120	11-563
Adjust (1025-940 or 1025-930) (AVIM)	11-121	11-565
Test (AVIM) (1025-820, 930 or 940)	11-119	11-561
Install Yaw	11-122	11-567
Install Pitch or Roll	11-123	11-571
Install Thrust	11-124	11-574
Remove Thrust	11-112	11-539
Remove Pitch or Roll	11-113	11-541
Remove Yaw	11-114	11-543
Viscous Damper, Connecting Links		
Remove Thrust or Pitch	11-125	11-577
Install Thrust or Pitch	11-126	11-578
Remove Roll	11-127	11-581
Install Roll	11-128	11-582
Remove Yaw	11-129	11-584
Install Yaw	11-130	11-585
Viscous Damper, Arms		
Remove Yaw, Thrust, Roll or Pitch	11-138	11-602
Install Yaw, Thrust, Roll or Pitch	11-139	11-603
W		
Walkway, Cabin Crown		
Repair	2-171	2-570
Damage Requiring Replacement (AVIM)	2-173	2-573
Minor Damage	2-172	2-572
Walkways, Special Finish	2-356	2-1242
Washers, Use of	2-334	2-1165
Water Wash, Engine (With 74)		
Nozzles and Manifolds, Replace	4-141	4-464

	Task	Page
Water and Air Pressure Hoses, Install	4-143	4-472
Water and Air Pressure Hoses, Remove	4-142	4-468
Procedure	4-145	4-480
Preservation, Compressor	4-146	4-482
Wear Sleeve, Pitch Shaft		
Install	5-27	5-138
Remove	5-26	5-137
Weather Protective Cover, Rotor Controls		
Install	5-138	5-775
Remove	5-136	5-740
Repair (AVIM)	5-137	5-743
Repair Composite (AVIM)	5-137.1	5-754
Web Repair, Backing Plate	2-363	2-1250
Weigh Helicopter		
3-Point (AVIM)	1-30	1-95
4-Point (AVIM)	1-31	1-104
Wheel and Tire Assembly, Aft Landing Gear		
Install	3-12.1	3-44
Remove	3-7.1	3-25
Wheel and Tire Assembly, Forward Landing Gear		
Install	3-12	3-39
Remove	3-7	3-22
Wheel Bearing		
Inspect	3-33	3-85
Wheel Brake Hydraulic System (Description)	7-135	7-608
Winch		
Description, Theory of Operation	14-1	14-2
Install	14-9	14-32
Remove	14-4	14-22
Time (AVIM)	14-7	14-29
Winch Components		
Cable		
Clean and Inspect	14-2	14-8
Install	14-11	14-39
Remove	14-10	14-35

	Task	Page
Chains		
Clean and Inspect (AVIM)	14-6	14-27
Install (AVIM)	14-8	14-30
Remove (AVIM)	14-5	14-25
Control Grip		
Assemble (AVIM)	9-160	9-639
Disassemble (AVIM)	9-159	9-635
Install	9-162	9-646
Remove	9-158	9-634
Test (AVIM)	9-161	9-643
Hook and Cable Assembly		
Inspect	14-12	14-43
Install	14-14	14-46
Remove	14-13	14-45
Limit Switch		
Adjust	14-3	14-10
Replace	14-3.1	14-17
Motor		
Install	7-248	7-921
Remove	7-247	7-919
Tackle/Cable Blocks		
Install (Rescue Mode)	14-22	14-58
Remove (Rescue Mode)	14-21	14-57
Window Inspection, Forward And Aft Cargo Hook		
Install	16-20	16-111
Remove	16-19	16-110
Window, Lower Fixed, Jettisonable Door - See Jettisonable Door Lower Fixed Window		
Window Panel, Cockpit Crown - See Cockpit Crown Window Panel		
Window Repair - See Windshield		
Window Restoration - See Transparent Plastic Finish Restoration		
Window, Upper Fixed, Jettisonable Door - See Jettisonable Door Upper Fixed Window		
Window, Cabin - See Cabin Windows		
Windshield		
Clean	1-77.1	1-290
Inspect	2-41	2-214
Leak Check	2-61	2-267
Repair (Plastic)	12-42	12-216
Test, Anti-Fogging	12-2	12-6
Windshield Anti-Icing System		
Control Boxes		

Install	12-4	12-12
Remove	12-3	12-10
Element, Test		
Relays		
Install	12-6	12-17
Remove	12-5	12-14
Windshield, Center, Mixed Plastic and Glass		
Install	2-53	2-248
Remove	2-52	2-246
Windshield, Glass, Center		
Install	2-47	2-230
Remove	2-44	2-221
Windshield, Glass, Pilot or Copilot		
Install	2-46	2-227
Remove	2-43	2-218
Windshield, Isolation Mounts		
Install	2-40	2-212
Remove	2-39	2-210
Windshield, Plastic, Center		
Install	2-51	2-242
Remove	2-49	2-236
Windshield, Plastic, Pilot or Copilot		
Install	2-50	2-238
Remove	2-48	2-233
Windshield Support Structure Rubber Strip		
Replace	2-45	2-223
Windshield Wiper System		
Actuator (Converter)		
Install	12-49	12-109
Remove	12-48	12-107
Arm		
Adjust Pressure (Wiper XW2110-H-18)	12-37	12-87
Adjust Pressure (XW2110-S-18)	12-38	12-89
Inspect	12-40	12-93
Install	12-41	12-94
Remove	12-39	12-91
Blade		
Inspect	12-40	12-93
Install	12-36	12-85
Remove	12-35	12-84
Drive Shaft		
Install	12-47	12-106

	Task	Page
Remove	12-46	12-105
Motor		
Brush Replacement (AVIM)	12-43	12-97
Install	12-45	12-103
Remove	12-42	12-96
Test	12-44	12-100
Wiper Blade, Windshield - Blade, Windshield Wiper		
Wire Harness and Solenoid Cover, Forward and Aft Cargo Hook		
Install	16-16	16-105
Remove	16-15	16-103
Wire Mesh Corrosion Repair, Rotary-Wing Blade - See Blade, Rotary-Wing		
Wire Rope (Cable), Winch - See Winch Components		
Work Platform, Engine - See Engine Work Platform		
Work Platform Forward		
Inspect For Chafing	2-2.1	2-11
Install	2-70	2-296
Remove	2-69	2-294
Work Platform, Pylon		
Inspect For Chafing	2-2.1	2-11
Install	2-292	2-999
Install (Composite)	2-292.1	2-1000
Latch		
Install	2-291	2-979
Remove	2-290	2-977
Remove	2-289	2-972
Remove (Composite)	2-289.1	2-974
Repair (Composite)	2-291.1	2-981
Y		
Yaw And Roll Travel Combined Check	11-37	11-139
Yaw And Thrust Pallet Idler Bellcranks Rigged - See Rig Pallet Thrust And Yaw Idler Bellcranks		
Yaw, Thrust, Roll or Pitch Viscous Damper Arms		
Install	11-139	11-603
Remove	11-138	11-602
Yaw Balance Spring		
Adjust	11-136	11-597
Yaw Controls Travel Check	11-35	11-129
Yaw Idler Bellcrank, Control Pallet STA 95.00 - See Control Pallet STA 95.00 Yaw Idler Bellcrank		

Yaw or Thrust Intermediate Bellcranks

Clean - See Clean Flight Control System

Inspect - Corrosion - See Corrosion Bellcranks, Inspect

Inspect - General - See Bellcranks and Idler Arms, Inspect

Install 11-183 11-724

Remove 11-182 11-722

Repair - General - See Control Arms and Bellcranks, Repair

Repair - Finish - See Finish Bellcrank and Arms

Yaw Intermediate Connecting Links - See Connecting Links, Yaw Intermediate

Yaw Magnetic Brake

Adjust (AVIM) 11-151 11-628

Install 11-152 11-630

Remove 11-148 11-623

Test (AVIM) 11-150 11-625

Yaw Or Roll Control Position Transducer - See Transducer Roll or Yaw Control Position

Yaw Pitch, Or Roll Travel Quadrant Cockpit - See Cockpit Travel Quadrant Pitch, Roll Or Yaw

Yaw, Roll Or Thrust ILCA Input Connecting Link Rigging - See Rig Roll, Yaw Or Thrust ILCA Input Connecting Links

Yaw Spring Assembly - See Pitch, Roll or Yaw Spring Assembly for Adjust, Assemble, Disassemble, or Test (AVIM)

Install 11-146 11-618

Remove 11-140 11-605

Yaw Viscous Damper Connecting Link

Install 11-130 11-585

Remove 11-129 11-584

Yoke, Aft LCT

Clean - See Clean Flight Control System

Inspect 11-226 11-882

Inspect - General 11-7 11-36

Install 11-233 11-904

Remove 11-227 11-884

Repair 11-228 11-888

Yoke Bearings, Aft LCT

Install (AVIM) 11-230 11-892

Remove (AVIM) 11-229 11-890

Yoke Bearings, Forward LCT

Install (AVIM) 11-214 11-844

	Task	Page
Remove (AVIM)	11-213	11-842
Yoke Bushings, Aft LCT		
Install (AVIM)	11-232	11-899
Remove (AVIM)	11-231	11-896
Yoke Bushings, Forward LCT		
Install (AVIM)	11-216	11-850
Remove (AVIM)	11-215	11-848
Yoke, Forward LCT		
Clean - See Clean Flight Control System		
Inspect	11-211	11-836
Inspect - General	11-7	11-36
Install	11-217	11-854
Remove	11-212	11-839

By Order of the Secretary of the Army:

Official:

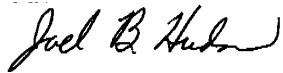

JOEL B. HUDSON
Administrative Assistant to the
Secretary of the Army
0220715

ERIC K. SHINSEKI
General, United States Army
Chief of Staff

DISTRIBUTION:

To be distributed in accordance with Initial Distribution Number (IDN) 311199, requirements for TM 55-1520-240-23-11.

These are the instructions for sending an electronic 2028

The following format must be used if submitting an electronic 2028. The subject line must be exactly the same and all fields must be included; however only the following fields are mandatory: 1, 3, 4, 5, 6, 7, 8, 9, 10, 13, 15, 16, 17, and 27.

From: "Whomever" <whomever@wherever.army.mil>

To: 2028@redstone.army.mil

Subject: DA Form 2028

1. **From:** Joe Smith
2. **Unit:** home
3. **Address:** 4300 Park
4. **City:** Hometown
5. **St:** MO
6. **Zip:** 77777
7. **Date Sent:** 19-OCT-93
8. **Pub no:** 55-2840-229-23
9. **Pub Title:** TM
10. **Publication Date:** 04-JUL-85
11. **Change Number:** 7
12. **Submitter Rank:** MSG
13. **Submitter FName:** Joe
14. **Submitter MName:** T
15. **Submitter LName:** Smith
16. **Submitter Phone:** 123-123-1234
17. **Problem:** 1
18. **Page:** 2
19. **Paragraph:** 3
20. **Line:** 4
21. **NSN:** 5
22. **Reference:** 6
23. **Figure:** 7
24. **Table:** 8
25. **Item:** 9
26. **Total:** 123
27. **Text:**

This is the text for the problem below line 27.

RECOMMENDED CHANGES TO PUBLICATIONS AND BLANK FORMS <small>For use of this form, see AR 25-30; the proponent agency is ODISC4.</small>	Use Part II (<i>reverse</i>) for Repair Parts and Special Tool Lists (RPSTL) and Supply Catalogs/Supply Manuals (SC/SM)	DATE <h2 style="text-align: center;">8/30/02</h2>
--	---	--

TO: (<i>Forward to proponent of publication or form</i>)(<i>Include ZIP Code</i>) Commander, U.S. Army Aviation and Missile Command ATTN: AMSAM-MMC-MA-NP Redstone Arsenal, 35898	FROM: (<i>Activity and location</i>)(<i>Include ZIP Code</i>) MSG, Jane Q. Doe 1234 Any Street Nowhere Town, AL 34565
--	--

PART 1 - ALL PUBLICATIONS (EXCEPT RPSTL AND SC/SM) AND BLANK FORMS

PUBLICATION/FORM NUMBER <h3 style="text-align: center;">TM 9-1005-433-24</h3>	DATE <h3 style="text-align: center;">16 Sep 2002</h3>	TITLE Organizational, Direct Support, And General Support Maintenance Manual for Machine Gun, .50 Caliber M3P and M3P Machine Gun Electrical Test Set Used On Avenger Air Defense Weapon System
--	--	---

ITEM NO.	PAGE NO.	PARA-GRAPH	LINE NO. *	FIGURE NO.	TABLE NO.	RECOMMENDED CHANGES AND REASON
1	WP0005 PG 3		2			Test or Corrective Action column should identify a different WP number.
<div style="border: 2px solid black; padding: 20px; font-size: 48px; font-weight: bold; letter-spacing: 0.5em;"> SAMPLE </div>						

* Reference to line numbers within the paragraph or subparagraph.

TYPED NAME, GRADE OR TITLE <h3 style="text-align: center;">MSG, Jane Q. Doe, SFC</h3>	TELEPHONE EXCHANGE/ AUTOVON, PLUS EXTENSION <h3 style="text-align: center;">788-1234</h3>	SIGNATURE
--	---	-----------

TO: (Forward direct to addressee listed in publication) Commander, U.S. Army Aviation and Missile Command ATTN: AMSAM-MMC-MA-NP Redstone Arsenal, 35898	FROM: (Activity and location) (Include ZIP Code) MSG, Jane Q. Doe 1234 Any Street Nowhere Town, AL 34565	DATE 8/30/02
---	--	------------------------

PART II - REPAIR PARTS AND SPECIAL TOOL LISTS AND SUPPLY CATALOGS/SUPPLY MANUALS

PUBLICATION NUMBER			DATE	TITLE				
PAGE NO.	COLM NO.	LINE NO.	NATIONAL STOCK NUMBER	REFERENCE NO.	FIGURE NO.	ITEM NO.	TOTAL NO. OF MAJOR ITEMS SUPPORTED	RECOMMENDED ACTION
SAMPLE								

PART III - REMARKS (Any general remarks or recommendations, or suggestions for improvement of publications and blank forms. Additional blank sheets may be used if more space is needed.)

TYPED NAME, GRADE OR TITLE MSG, Jane Q. Doe, SFC	TELEPHONE EXCHANGE/AUTOVON, PLUS EXTENSION 788-1234	SIGNATURE
--	---	-----------

RECOMMENDED CHANGES TO PUBLICATIONS AND BLANK FORMS <small>For use of this form, see AR 25-30; the proponent agency is ODISC4.</small>	Use Part II (reverse) for Repair Parts and Special Tool Lists (RPSTL) and Supply Catalogs/Supply Manuals (SC/SM)	DATE
--	--	------

TO: (Forward to proponent of publication or form)(Include ZIP Code)	FROM: (Activity and location)(Include ZIP Code)
---	---

PART 1 - ALL PUBLICATIONS (EXCEPT RPSTL AND SC/SM) AND BLANK FORMS

PUBLICATION/FORM NUMBER TM 9-1005-433-24	DATE 16 Sep 2002	TITLE Organizational, Direct Support, And General Support Maintenance Manual for Machine Gun, .50 Caliber M3P and M3P Machine Gun Electrical Test Set Used On Avenger Air Defense Weapon System
--	----------------------------	---

ITEM NO.	PAGE NO.	PARA-GRAPH	LINE NO. *	FIGURE NO.	TABLE NO.	RECOMMENDED CHANGES AND REASON

** Reference to line numbers within the paragraph or subparagraph.*

TYPED NAME, GRADE OR TITLE	TELEPHONE EXCHANGE/ AUTOVON, PLUS EXTENSION	SIGNATURE
----------------------------	--	-----------

TO: (Forward direct to addressee listed in publication)	FROM: (Activity and location) (Include ZIP Code)	DATE
--	---	-------------

PART II - REPAIR PARTS AND SPECIAL TOOL LISTS AND SUPPLY CATALOGS/SUPPLY MANUALS

PUBLICATION NUMBER	DATE	TITLE
---------------------------	-------------	--------------

PAGE NO.	COLM NO.	LINE NO.	NATIONAL STOCK NUMBER	REFERENCE NO.	FIGURE NO.	ITEM NO.	TOTAL NO. OF MAJOR ITEMS SUPPORTED	RECOMMENDED ACTION

PART III - REMARKS (Any general remarks or recommendations, or suggestions for improvement of publications and blank forms. Additional blank sheets may be used if more space is needed.)

--

TYPED NAME, GRADE OR TITLE	TELEPHONE EXCHANGE/AUTOVON, PLUS EXTENSION	SIGNATURE
----------------------------	--	-----------

The Metric System and Equivalents

Linear Measure

1 centimeter = 10 millimeters = .39 inch
 1 decimeter = 10 centimeters = 3.94 inches
 1 meter = 10 decimeters = 39.37 inches
 1 dekameter = 10 meters = 32.8 feet
 1 hectometer = 10 dekameters = 328.08 feet
 1 kilometer = 10 hectometers = 3,280.8 feet

Weights

1 centigram = 10 milligrams = .15 grain
 1 decigram = 10 centigrams = 1.54 grains
 1 gram = 10 decigrams = .035 ounce
 1 decagram = 10 grams = .35 ounce
 1 hectogram = 10 decagrams = 3.52 ounces
 1 kilogram = 10 hectograms = 2.2 pounds
 1 quintal = 100 kilograms = 220.46 pounds
 1 metric ton = 10 quintals = 1.1 short tons

Liquid Measure

1 centiliter = 10 milliliters = .34 fl. ounce
 1 deciliter = 10 centiliters = 3.38 fl. ounces
 1 liter = 10 deciliters = 33.81 fl. ounces
 1 dekaliter = 10 liters = 2.64 gallons
 1 hectoliter = 10 dekaliters = 26.42 gallons
 1 kiloliter = 10 hectoliters = 264.18 gallons

Square Measure

1 sq. centimeter = 100 sq. millimeters = .155 sq. inch
 1 sq. decimeter = 100 sq. centimeters = 15.5 sq. inches
 1 sq. meter (centare) = 100 sq. decimeters = 10.76 sq. feet
 1 sq. dekameter (are) = 100 sq. meters = 1,076.4 sq. feet
 1 sq. hectometer (hectare) = 100 sq. dekameters = 2.47 acres
 1 sq. kilometer = 100 sq. hectometers = .386 sq. mile

Cubic Measure

1 cu. centimeter = 1000 cu. millimeters = .06 cu. inch
 1 cu. decimeter = 1000 cu. centimeters = 61.02 cu. inches
 1 cu. meter = 1000 cu. decimeters = 35.31 cu. feet

Approximate Conversion Factors

<i>To change</i>	<i>To</i>	<i>Multiply by</i>	<i>To change</i>	<i>To</i>	<i>Multiply by</i>
inches	centimeters	2.540	ounce-inches	Newton-meters	.007062
feet	meters	.305	centimeters	inches	.394
yards	meters	.914	meters	feet	3.280
miles	kilometers	1.609	meters	yards	1.094
square inches	square centimeters	6.451	kilometers	miles	.621
square feet	square meters	.093	square centimeters	square inches	.155
square yards	square meters	.836	square meters	square feet	10.764
square miles	square kilometers	2.590	square meters	square yards	1.196
acres	square hectometers	.405	square kilometers	square miles	.386
cubic feet	cubic meters	.028	square hectometers	acres	2.471
cubic yards	cubic meters	.765	cubic meters	cubic feet	35.315
fluid ounces	milliliters	29.573	cubic meters	cubic yards	1.308
pints	liters	.473	milliliters	fluid ounces	.034
quarts	liters	.946	liters	pints	2.113
gallons	liters	3.785	liters	quarts	1.057
ounces	grams	28.349	liters	gallons	.264
pounds	kilograms	.454	grams	ounces	.035
short tons	metric tons	.907	kilograms	pounds	2.205
pound-feet	Newton-meters	1.356	metric tons	short tons	1.102
pound-inches	Newton-meters	.11296			

Temperature (Exact)

F	Fahrenheit temperature	5/9 (after subtracting 32)	Celsius temperature	C
---	---------------------------	-------------------------------	------------------------	---

